

P. L. Dreike and L. P. Mix
 Sandia National Laboratories, Albuquerque, NM 87185

Summary

Diode voltage on the PBFA-I accelerator has not been measured by conventional techniques. Instead, diode voltage is obtained by time-resolved energy analysis of protons accelerated from a 1 cm² flashover source in the feed a few cm from the diode. The analyzer is a Thomson Parabola with a pulsed electric field. The magnetic and electric fields sweep a proton beamlet across a piece of CR-39 track recording plastic. Proton energy, and diode voltage, are obtained from the magnetic deflection. Absolute timing is obtained from a timing fiducial in the electric deflection voltage, which is seen in the CR-39 record. The magnetic deflection has been calibrated by two techniques and is believed to be accurate to better than 5%. The resolution of the instrument is nearly 100 keV at 2 MeV. Absolute timing and time resolution are both about 4 ns. We discuss design considerations and present sample measurements.

Introduction

Measurement of the diode voltage on the PBFA-I accelerator is necessary in order to focus an ion beam, but it has proven to be a challenging measurement to make. The thirty-six module accelerator is operated with eighteen modules in positive polarity and eighteen modules in negative polarity. These are coupled together by a magnetically insulated vacuum convolute which drives the diode's anode positive and the cathode negative with respect to ground. Inductance and electron loss in the magnetically insulated feed have led us to measure diode voltage at the accelerating gap or within the final few cm of the feeds. This is done by time-resolved energy analysis of protons accelerated either in the diode, or from 1 cm² flashover sources in the feed a few cm from the diode gap. The energy analyzer is a Thomson Parabola, whose unique feature is a time-ramped electric field which allows time resolved measurements. A conventional Thomson Parabola uses static, parallel, magnetic and electric fields to give two transverse particle deflections whose magnitudes depend upon the particles' charge-to-mass ratio. In this paper we give a detailed discussion of our Thomson Parabola's design as well as show some sample measurements.

Design Considerations

The Thomson Parabola needs to satisfy several requirements. First, the direction in which protons are accelerated varies by several degrees during the course of the pulse because of the strong, time-varying fields in the magnetically insulated transmission lines or in the diodes. The required acceptance angle is 100 milliradians to 150 milliradians. Second, the minimum required energy and timing resolution is about 100 keV and 3 ns to make a useful time-resolved measurement of the diode voltage whose peak is 1 to 2 MV and has a full width at half maximum of 15 ns to 35 ns. Because of the Bremsstrahlung background in the diode, the recording medium is a nuclear track recording plastic, such as CR-39¹. In the PBFA-I environment it must also be rugged and

easy to install. A schematic drawing of the Thomson Parabola as it is used in the feeds is shown in Fig. 1 and a photograph is shown in Fig. 2.

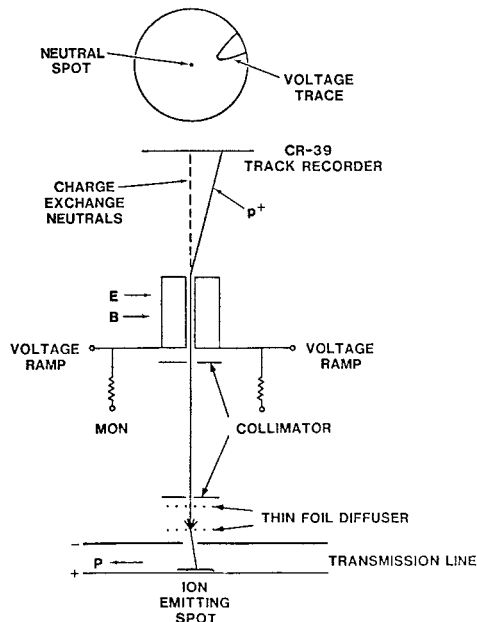

Figure 1. Schematic drawing of the Thomson Parabola.

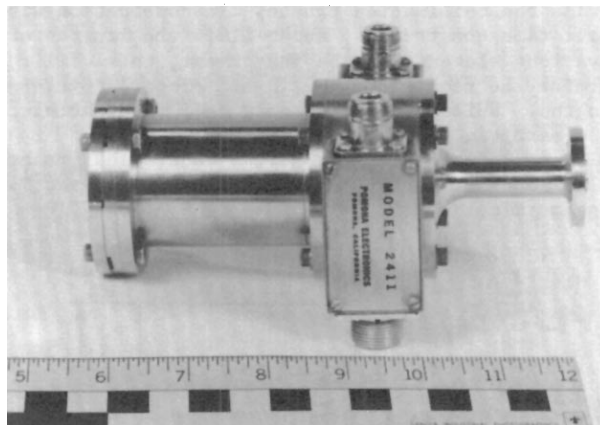

Figure 2. Photograph of the Thomson Parabola. The scale is in inches. The diffuser is attached on the right hand side.

The proton source is a 1 cm² patch of nylon mesh glued to the positive center electrode of the triple disk feed. It is expected to provide a space charge limited ion beam. Current densities of 10 to 200 A/cm² have been measured using Faraday cups. The magnetic fields in the feed are expected to bend the ion trajectories towards the axis of the accelerator (in the direction of the power flow). The magnitude of the deflection θ_d is given by

$$\theta_d = \sin^{-1} \sqrt{\frac{q}{2m} \frac{o^d}{4r} \frac{I}{\sqrt{V}}}$$

*This work was supported by the U. S. Department of Energy under contract DE-AC04-76-DP00789.

Report Documentation Page

Form Approved
OMB No. 0704-0188

Public reporting burden for the collection of information is estimated to average 1 hour per response, including the time for reviewing instructions, searching existing data sources, gathering and maintaining the data needed, and completing and reviewing the collection of information. Send comments regarding this burden estimate or any other aspect of this collection of information, including suggestions for reducing this burden, to Washington Headquarters Services, Directorate for Information Operations and Reports, 1215 Jefferson Davis Highway, Suite 1204, Arlington VA 22202-4302. Respondents should be aware that notwithstanding any other provision of law, no person shall be subject to a penalty for failing to comply with a collection of information if it does not display a currently valid OMB control number.

1. REPORT DATE JUN 1983	2. REPORT TYPE N/A	3. DATES COVERED -			
4. TITLE AND SUBTITLE PBFA-I Diode Voltage Measurements Using A Fast Proton Energy Analyzer		5a. CONTRACT NUMBER			
		5b. GRANT NUMBER			
		5c. PROGRAM ELEMENT NUMBER			
6. AUTHOR(S)		5d. PROJECT NUMBER			
		5e. TASK NUMBER			
		5f. WORK UNIT NUMBER			
7. PERFORMING ORGANIZATION NAME(S) AND ADDRESS(ES) Sandia National Laboratories, Albuquerque, NM 87185		8. PERFORMING ORGANIZATION REPORT NUMBER			
9. SPONSORING/MONITORING AGENCY NAME(S) AND ADDRESS(ES)		10. SPONSOR/MONITOR'S ACRONYM(S)			
		11. SPONSOR/MONITOR'S REPORT NUMBER(S)			
12. DISTRIBUTION/AVAILABILITY STATEMENT Approved for public release, distribution unlimited					
13. SUPPLEMENTARY NOTES See also ADM002371. 2013 IEEE Pulsed Power Conference, Digest of Technical Papers 1976-2013, and Abstracts of the 2013 IEEE International Conference on Plasma Science. Held in San Francisco, CA on 16-21 June 2013. U.S. Government or Federal Purpose Rights License.					
14. ABSTRACT					
15. SUBJECT TERMS					
16. SECURITY CLASSIFICATION OF:			17. LIMITATION OF ABSTRACT	18. NUMBER OF PAGES	19a. NAME OF RESPONSIBLE PERSON
a. REPORT unclassified	b. ABSTRACT unclassified	c. THIS PAGE unclassified	SAR	4	

q is the charge, m is the ion mass, d is the transmission line electrode separation, r is the radial position, I is the accelerator current, V is the voltage, and all units are in MKS. Early in the pulse when the current is low, the deflection is small. Late in the pulse, when current and voltage are, for example, 5 MA and 1 MV, the deflection is 140 mrad. Using time-integrated ion pinhole imaging, deflection angles of this size were observed. By imaging heavier carbon ions, the source was also seen to be non-uniform.

Because the protons are not well directed, a diffuser made from two thin gold foils is used to be sure that some protons always pass through the subsequent collimator. The foil thickness is much less than the proton range. From Hungerford², protons passing through a thin foil emerge with an angular distribution $f(\theta)$ due to multiple scattering which is approximately given by

$$f(\theta) \propto e^{-\theta^2/\sigma^2}$$

where θ is the deflection angle. For gold, the value of σ is approximately

$$\sigma \approx 0.12 \sqrt{t/E}$$

where t is the foil thickness in μm and E is the proton energy in MeV. Two foils, 0.5 μm to 0.8 μm thick, spaced 2 cm apart smooth out source non-uniformity and direct protons into the collimator. The energy loss in the foils is 0.1 MeV to 0.2 MeV. Some protons undergo charge exchange as they traverse the foil, emerging as neutral atoms which provide a zero deflection spot on the CR-39.

Resolution is, of course, limited by detector sensitivity, and the ion source intensity, which determine how fine the collimation can be. In combination with transit time constraints, which limit the lengths of the various elements of the instrument, this will determine the required magnetic and electric field strengths. While track recorders are, in principle, single particle detectors, a track density of $\sim 1 \times 10^5 \text{ cm}^{-2}$ is required to give a good, clear trace. We also impose a current constraint of $3 \times 10^{10} \text{ sec}^{-1}$. The geometrical details are shown in Fig. 3.

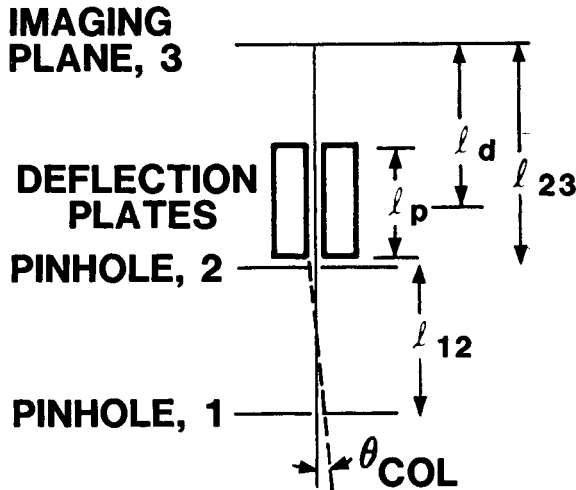

Figure 3. Sketch of the geometrical layout of the collimator and deflection plates showing various path lengths.

The collimation angle θ_{col} is given by

$$\theta_{\text{col}} = \frac{r_1 + r_2}{l_{12}}$$

where r_1 and r_2 are the radii of the entrance and exit pinholes of the collimator and l_{12} is their separation. The proton current through the collimator N_2 and the writing beam intensity I_3 are given approximately by

$$N_2 = \frac{j}{q} \frac{r_1^2 r_2^2 e^{-\theta^2/\sigma^2}}{\sigma^2 l_{12}^2} \theta^4 \text{col} l_{12}^2$$

$$I_3 = N_2 / \pi r_3^2 \sim \theta^2 \text{col}$$

$$r_3 = M r_1 + (1 + M) r_2,$$

$$M = l_{23} / l_{12}$$

where j is the incident current density, $e^{-\theta^2/\sigma^2} \approx 1/3$ is due to the diffuser, and r_3 is the radius of the beamlet at the detector. The intensity depends quadratically upon the collimation, but the current also depends on the square of the collimator length. It is desirable to limit the collimator length so that protons with different energies will have transit times to the deflection plates differing by < 3 ns. Including the diffuser and deflection plate length this gives $l_{12} = 6$ cm. The aperture radii must now be chosen to maximize the intensity for a given spot size, r_3 . One finds

$$r_1 = r_3 / 2 M$$

$$r_2 = r_3 / 2(1 + M)$$

Taking the intensity constraint ($I T_r = 1 \times 10^5 / \text{cm}^2$, where $T_r = 3$ ns is the desired time resolution) gives

$$r_3 = 4 M (1 + M) \sigma l_{12} e^{\theta^2/\sigma^2} \sqrt{qI/jT_r}$$

For $M = 2$, $\sigma = 0.15$, $\theta = 0.15$, and $j = 10 \text{ A/cm}^2$, then $r_3 = 2.6 \times 10^{-2} \text{ cm}$. Now that a minimum writing beam spot has been determined, we may estimate the strength of the deflection fields needed to meet our resolution requirements.

In Fig. 3 the deflection plates are sketched with a length l_p , with a distance l_d from the middle of the plates to the imaging plane. Assuming uniform field strengths B and $\mathcal{E}(t)$ between the plates, and negligible fringing fields, the magnetic and electric deflections Δ_B and Δ_E are given by

$$\Delta_B = \frac{qB l_p l_d}{\sqrt{m} \sqrt{E}}$$

$$\Delta_E = \frac{q(t) l_p l_d}{2E}$$

where E is the proton energy. The resolution requirements are

$$\frac{d\Delta_B}{dE} E_r, \frac{J\Delta_E}{\partial t} T_r \geq r_3$$

where E_r and T_r are the desired energy and time

resolutions. Maintaining $T_r = 3$ ns limits the plate transit time to < 2 ns. It was convenient to choose $\ell_p = 2.5$ cm and $\ell_d = 10$ cm. Then $B > 7.9$ kG and $d/dt > 1.3 \times 10^{12}$ V/cm/sec are required to obtain 0.1 MeV and 3 ns resolution for a 2 MV incident beam.

Apparatus and Results

The dimensions of our Thomson Parabolas are similar to those in the preceding examples. The magnetic deflection is provided by two 2.54 cm square rare earth permanent magnets separated by 0.2 cm. The average field strength is about 6 kG. The entire housing is made from mild steel to control the fringing fields and to shield against stray fields which may be present. The magnets also serve as the pole-pieces for the electric field; one is pulsed positive and the other negative with respect to ground.

The desired electric pulse would be a linear ramp with a timing fiducial which would be seen in the final CR-39 trace. This is approximated by the circuit shown in Fig. 4. The ~ 60 ns linear ramp is taken from the linear portion of a C_1LC_2 oscillator with a 110 ns half-period. In order to minimize jitter, a simple krytron (an EG&G KN-6B) is used to switch two oscillators, one charged positively and the other negative with respect to ground.

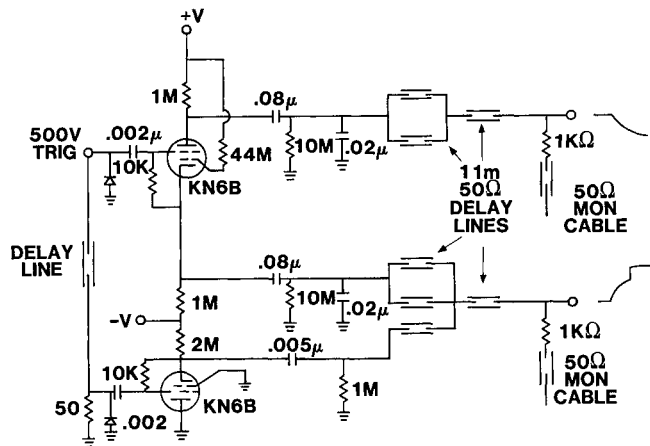

Figure 4. Schematic drawing of the electric deflection driver.

the other negatively to 3-4 kV. Because of the capacitive imbalance between C_1 and C_2 , there is a voltage ringup of about 1.6. Each side of the oscillator drives a pair of 11 m long 50Ω cables. These pairs then each drive a single 11 m long 50Ω cable which is terminated by a $1 k\Omega$ monitor resistor in the Thomson Parabola. The total ringing gain is about 3.2. This particular scheme has the virtue that jitter is minimized, and that only the connectors in the Thomson Parabola itself must hold even half of the deflection voltage. The timing fiducial is obtained using an RC decay, also switched by a KN6B krytron, which is added to the positive oscillator output using another coaxial cable. The final output wave, using a 3 kV charging voltage, is shown in Fig. 5.

Energy calibrations were obtained from precise mapping of the magnetic field and by passing a beam of known energy protons from a Van de Graaf accelerator through the parabolas. The two calibrations agreed to within 3%, which is our estimated accuracy of each calibration.

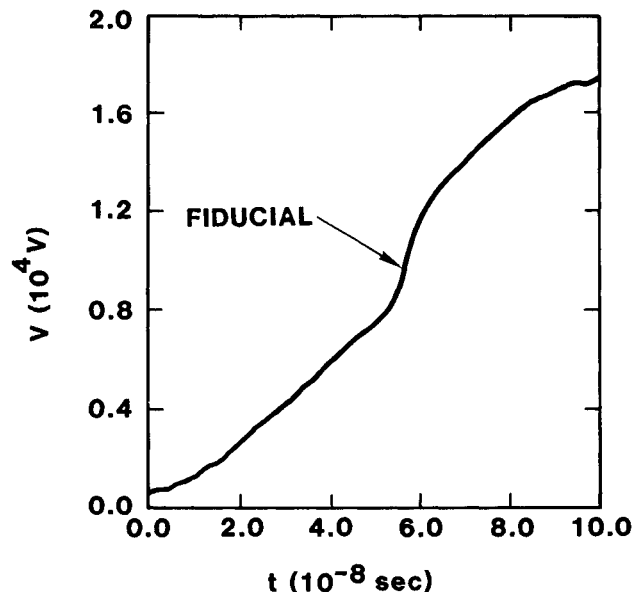

Figure 5. Voltage difference across the deflection plates using a 3 kV charging voltage. $d\mathcal{E}/dt = 0.8 \times 10^{11}$ V/cm/sec. in the linear portion.

Most of the analysis effort involves tying the energy from the magnetic deflection to the time from the electric deflection. The $\Delta_B - \Delta_E$ locus of a trace and the voltage on the deflection plates, $V_p(t)$, are measured. Knowing the particle energy, the electric deflection is given by the expression

$$\Delta_E = K V_p(t) / V(t - t_D(E))$$

where K is a constant, and $t_D(E)$ is the drift time between the ion source and the deflection plates. Working backward in time, we find the source voltage, $V(t)$. The most satisfying technique for obtaining K is to identify the fiducial step in $V_p(t)$ with a slope change in the trace, as in Fig. 6, obviating amplitude uncertainties in the recording system.

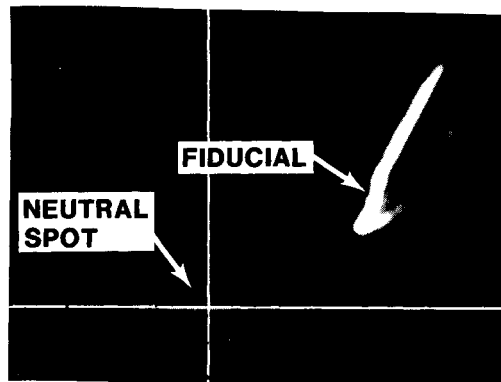

Figure 6. Photograph of the CR-39 showing a Thomson Parabola trace. The timing fiducial is clearly seen and the charge exchange neutral spot was clearly visible in the original.

To reduce the raw data, we first take a magnified photograph of the CR-39. To obtain good contrast this is done by sidelighting the plastic with a high intensity lamp, viewing against a black background. Proton tracks scatter light which has been trapped in the plastic by total internal reflection. Such a photograph is reproduced in Fig. 6. The trace is digitized and stored in the data acquisition system. A computer program gives $V(t)$, shown in Fig. 7.

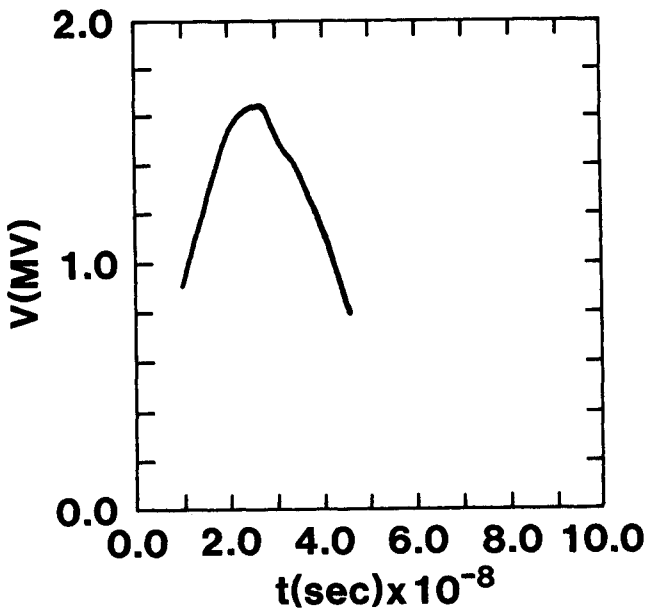

Figure 7. Diode voltage inferred from data like that shown in Figs. 5 and 6.

Conclusions

Two of the Thomson Parabola are now used routinely to make diode voltage measurements. In practice, the design objectives of 100 KV and 3 ns resolution at 2 MV, have been nearly met. The actual resolution of ~ 150 KV and 4 ns at 2 MV has proven to be adequate for experiments to date. They are also being used in other applications in our program requiring time-resolved proton energy measurements.

Acknowledgments

We would like to thank W. R. Wampler for performing energy calibrations with a Van de Graaf accelerator, and S. Booker for making precise magnetic field measurements. P. A. Miller and W. Boyer helped to mechanize the data analysis. K. Ennis, B. Boatman and R. Noack have provided able technical assistance.

References

1. S. P. Ahlen, P. B. Price, G. Tarle', p. 32, Phys. Today, Sept. 1981.
2. E. V. Hungerford, et al., Nucl. Phys. A197, 515 (1972).