

AN ADJUSTABLE LENGTH VOLTAGE DIVIDER FOR  
HIGHLY STRESSED TRANSMISSION LINES\*

by Steven R. Ashby

Physics International Company  
2700 Merced Street  
San Leandro, CA 94577

Abstract

A voltage divider has been developed for use in high electric field regions of liquid dielectric transmission lines. The monitor consists of an electrolyte-filled resistive primary divider, connected to a 100/1 discrete resistor secondary divider. The length of the primary divider is adjustable from 10 to 30 cm to accommodate flush mounting of the end electrodes for a range of transmission line spacings. We have routinely used the divider in water at fields > 250 kV/cm. The monitor, including the secondary divider, has a less than 5 ns risetime, and has a division ratio of 4,000 to 15,000 to 1 over its adjustment range. For a fixed length, the division ratio is independent of electrolyte resistivity.

Introduction

Diagnostic requirements for large, water dielectric, pulsed power generators at PI have inspired the development of many novel monitors in the past two decades<sup>1,2,3</sup>. EAGLE, a 4.6 TW bounded triplate, pulsed power testbed developed for DNA as part of the ROULETTE Program<sup>4</sup>, presented some different requirements for diagnostics. Figure 1 shows the EAGLE module, composed

	d	V	t
A	30 cm	3.1 MV	1.3 μs
B	19 cm	3.4 MV	300 ns
C,D,E	10-15 cm	2.8 MV	100 ns

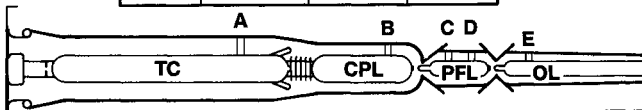

Figure 1. EAGLE resistive monitor locations. The chart shows the line spacing (d), the peak voltage (V), and the pulse length (t) at each location.

of four water dielectric pulse-shaping sections. Separated by energy transfer switches, each of these adjustable sections has different pulse characteristics, with pulse lengths from 70 to 1300 ns, electric fields in the water from 100 to 300 kV/cm over triplate spacings from 10 to 30 cm.

Background

To optimize machine operation, it was required to measure the voltage waveform impressed upon each transmission line, preferably as near to the switches as feasible. In the past, most voltage measurements in the water insulated section of PI's pulsed power generators have been done with capacitive dividers. Capacitive dividers, because they measure the electric field in the neighborhood of the ground conductor, can be easily

\*Work sponsored by the Defense Nuclear Agency. DF0ISR Case Number 0213.

installed in a generator without major electrical or mechanical impact. But for the same reason, capacitive dividers have some limitations. First, due to the finite resistance of the monitoring leg, the probe displays an RC roll-off at low frequencies and the waveform must be corrected for this decay. Second, the monitors must be calibrated in place to correlate the potential difference between the high voltage and ground connection with the field at the monitor. In the immediate vicinity of a switch, this can be especially difficult due to the difference in the field distributions when the switch is open and closed. These two factors make accurate measurements of pre-pulse and switch voltage very difficult. Since investigation of high power gas and water switching was a primary goal of the EAGLE testbed, these limitations were serious and we chose to incorporate a resistive divider for EAGLE.

Resistive dividers have the advantage that in making a direct connection from the high voltage electrode to ground, they measure the potential difference between the conductors. Because of this, they do not display the low frequency roll-off intrinsic to capacitive dividers and also can be bench calibrated to determine their division ratio since it is independent of field geometry. Resistive monitors are more difficult to design, however, since the monitor envelope and resistive medium are subject to, and must withstand, the full voltage under measurement.

Theory

The equivalent circuit of a resistive voltage monitor is shown in Figure 2. If we neglect the

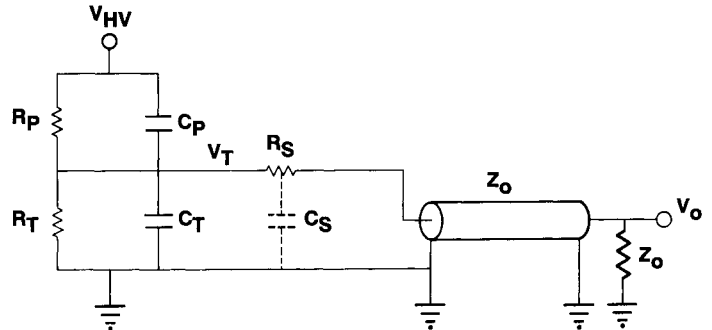

Figure 2. Equivalent circuit of a resistive voltage monitor.

effects of the secondary divider, the primary division ratio is:

$$D_{PR} = \frac{R_T}{R_T + R_P} \quad (1)$$

where  $R_P$  is the resistance above the tap-off and  $R_T$  is the resistance from tap-off to ground. The

## Report Documentation Page

*Form Approved*  
*OMB No. 0704-0188*

Public reporting burden for the collection of information is estimated to average 1 hour per response, including the time for reviewing instructions, searching existing data sources, gathering and maintaining the data needed, and completing and reviewing the collection of information. Send comments regarding this burden estimate or any other aspect of this collection of information, including suggestions for reducing this burden, to Washington Headquarters Services, Directorate for Information Operations and Reports, 1215 Jefferson Davis Highway, Suite 1204, Arlington VA 22202-4302. Respondents should be aware that notwithstanding any other provision of law, no person shall be subject to a penalty for failing to comply with a collection of information if it does not display a currently valid OMB control number.

1. REPORT DATE <b>JUN 1983</b>	2. REPORT TYPE <b>N/A</b>	3. DATES COVERED <b>-</b>	
4. TITLE AND SUBTITLE <b>An Adjustable Length Voltage Divider For Highly Stressed Transmission Lines</b>		5a. CONTRACT NUMBER	
		5b. GRANT NUMBER	
		5c. PROGRAM ELEMENT NUMBER	
6. AUTHOR(S)		5d. PROJECT NUMBER	
		5e. TASK NUMBER	
		5f. WORK UNIT NUMBER	
7. PERFORMING ORGANIZATION NAME(S) AND ADDRESS(ES) <b>Physics International Company 2700 Merced Street San Leandro, CA 94577</b>		8. PERFORMING ORGANIZATION REPORT NUMBER	
9. SPONSORING/MONITORING AGENCY NAME(S) AND ADDRESS(ES)		10. SPONSOR/MONITOR'S ACRONYM(S)	
		11. SPONSOR/MONITOR'S REPORT NUMBER(S)	
12. DISTRIBUTION/AVAILABILITY STATEMENT <b>Approved for public release, distribution unlimited</b>			
13. SUPPLEMENTARY NOTES <b>See also ADM002371. 2013 IEEE Pulsed Power Conference, Digest of Technical Papers 1976-2013, and Abstracts of the 2013 IEEE International Conference on Plasma Science. Held in San Francisco, CA on 16-21 June 2013. U.S. Government or Federal Purpose Rights License.</b>			
14. ABSTRACT <b>A voltage divider has been developed for use in high electric field regions of liquid dielectric transmission lines. The monitor consists of an electrolyte-filled resistive primary divider, connected to a 100/1 discrete resistor secondary divider. The length of the primary divider is adjustable from 10 to 30 em to accommodate flush mounting of the end electrodes for a range of transmission line spacings. We have routinely used the divider in water at fields &gt; 250 kV/cm. The monitor, including the secondary divider, has a less than 5 ns risetime, and has a division ratio of 4,000 to 15,000 to 1 over its adjustment range. For a fixed length, the division ratio is independent of electrolyte resistivity.</b>			
15. SUBJECT TERMS			
16. SECURITY CLASSIFICATION OF:			17. LIMITATION OF ABSTRACT <b>SAR</b>
a. REPORT <b>unclassified</b>	b. ABSTRACT <b>unclassified</b>	c. THIS PAGE <b>unclassified</b>	
			18. NUMBER OF PAGES <b>3</b>
			19a. NAME OF RESPONSIBLE PERSON

stray capacitances  $C_P$  and  $C_T$  play an important part in the high frequency behavior of the probe. At frequencies greater than  $1/(R_P C_P)$ , the monitor behaves as a capacitive probe with a division ratio

$$D_{PC} = \frac{C_P}{C_T + C_P} \quad (2)$$

It is desirable to equate the capacitive and resistive division ratios so that the response of the monitor is flat for all frequencies.

Setting these equal

$$\frac{C_P}{C_T + C_P} = \frac{R_T}{R_T + R_P} \quad (3)$$

implies

$$R_T C_T = R_P C_P \quad (4)$$

This condition is sufficient to insure the division ratio of the primary divider is independent of frequency.

In reality, however, all these values can be frequency and voltage independent due to dielectric, electrolyte, and electrode materials, and this dependence must be taken into account in the design, calibration, and use of the monitor. RC constants which are not matched will result in an uneven frequency response for the monitor. The difference in RC constants determines the magnitude of the change in division ratio over frequency; and the frequency at which it occurs is determined by the absolute value RC. For a factor of ten difference in RC constants, the response versus frequency curve is shown in Figure 3.

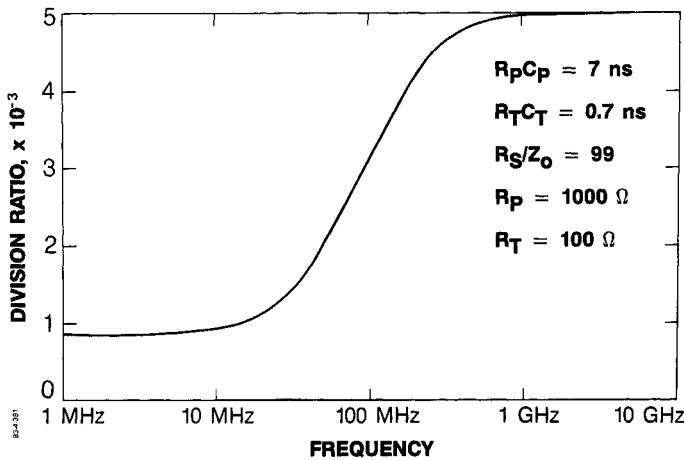

Figure 3. The response of a resistive monitor when  $R_T C_T \neq R_P C_P$ .

The simplest way to match the RC constants is to use the same method to construct the two resistive elements. In practice, this is achieved by inserting a tap-off electrode between the high voltage and ground electrode of the divider column and allowing the electrolyte solution to fill both sides of the tap-off. In the ideal case, the tap-off is a thin disk placed a distance  $L_T$  from the ground end of an electrolyte column of length  $L_P + L_T$  and uniform cross-section  $A_P = A_T$ . Then, if we neglect fringing fields,

$$R_P = \rho \frac{L_P}{A_P}, \quad R_T = \rho \frac{L_T}{A_T} \quad (5)$$

$$C_P = \epsilon \frac{A_P}{L_P}, \quad C_T = \epsilon \frac{A_T}{L_T} \quad (6)$$

$$R_P C_P = \rho \frac{L_P}{A_P} \epsilon \frac{A_P}{L_P} = \rho \epsilon = \rho \frac{L_T}{A_T} \epsilon \frac{A_T}{L_T} = R_T C_T \quad (7)$$

which is what we require for flat response. We use different symbols for the areas because the electrical connection to the monitoring circuit is made through the center of the ground electrode, and, therefore, the tap-off area is not necessarily equal to the column area. If the electric fields external to the monitor are parallel and equal to the fields in the electrolyte column, the fields do not bend and the above simple equations can be used. This is achieved by placing the ground and high voltage electrode of the monitor flush with those of the transmission line. Surrounding the column with a low dielectric constant electrolyte container also aids in de-coupling the interior and exterior fields and minimizing the contribution of any fringing fields.

Another benefit of this construction method is evident if one figures the primary division ratio

$$D_{PR} = \frac{R_T}{R_T + R_P} = \frac{\rho \frac{L_T}{A_T}}{\rho \frac{L_T}{A_T} + \rho \frac{L_P}{A_P}} = \frac{L_T}{L_T + L_P \frac{A_T}{A_P}} \quad (8)$$

which can be seen to be purely geometric and independent of both  $\rho$  and  $\epsilon$ . In addition, from Equation 8 it can be seen that if one can make  $A_T$  and  $A_P$  equal, then

$$D_{PR} = \frac{L_T}{L_T + L_P} \quad (9)$$

This provides a standard tap-off from which we can construct a primary monitor of any length whose division ratio is known in advance. This is also desirable since now the tap-off is placed physically at the location of its corresponding electrical potential.

The secondary divider, whose effects we have neglected, drops the voltage to levels which can be carried by conventional coax cables. For this particular monitor, we have total column lengths  $10 \text{ cm} < (L_T + L_P) < 30 \text{ cm}$ . For a reasonable  $L_T$  of  $\sim 1 \text{ cm}$ ,  $0.1 < D_{PR} < 0.03$ . Since the voltage on the tap-off is  $V_T = D_{PR} V_{HV}$ , at  $V_{HV} = 3 \text{ MV}$  we have  $90 \text{ kV} < V_T < 300 \text{ kV}$ . The secondary divider drops this voltage by 100 times to a level that can be transmitted on coaxial cable. Since  $R_S \gg R_T$ , the secondary divider does not interfere with the electrical division ratio of the primary divider. Rigorously, the division ratios of the primary are

$$D_{PR} = \frac{R_T \parallel (R_S + Z_0)}{R_T \parallel (R_S + Z_0) + R_P} \quad (10)$$

and

$$D_{PC} = \frac{C_P}{C_T + C_P} \quad (11)$$

( $\parallel$  indicates the parallel combination) which simplify to (1) and (2) if:  $R_S \gg R_T$  and  $C_S \ll C_T$ .

The secondary is another resistive divider with division ratio

$$D_S = \frac{Z_0}{Z_0 + R_S} \quad (12)$$

The total division ratio of the monitor is then

$$D = \frac{R_T \parallel (R_S + Z_0)}{R_T \parallel (R_S + Z_0) + R_P} \frac{Z_0}{Z_0 + R_S} \approx \frac{R_T}{R_T + R_P} \frac{Z_0}{R_S + Z_0} \quad (13)$$

### Application

This monitor, which appears in Figure 4, has some special constraints due to its application in

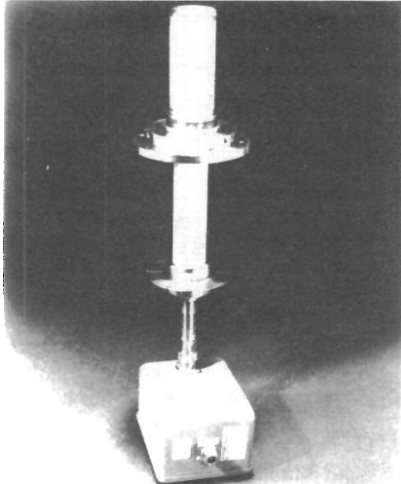

Figure 4. The resistive monitor. The box at the bottom is the secondary divider. The long cylinder at the top accommodates the change of length.

parallel plate lines under large electrical stresses. We usually limit the voltage at the input of the secondary divider (which is of standard design) to less than 100 kV. Since this input voltage is the tap-off voltage, the effective length of the tap-off stick-out ( $L_T$ ) should be small in relation to the length of the column above it ( $L_P$ ). There are limits to  $L_T$  due to mechanical constraints and the fact that in use, some pitting and plating of electrodes occurs from current transfer, causing surface irregularities. We chose  $L_T \approx 3$  mm. It is also crucial to place the tap-off electrode electrically (by choosing  $R_P$  and  $R_T$ ) at the potential corresponding to its physical location between the plates. This prevents field concentrations on the surface and bulk of the plastic that could start breakdowns in the monitor or in the surrounding water dielectric.

The adjustability of the interline spacing of EAGLE was an important factor in the mechanical design of this monitor. To vary the wave impedance of the EAGLE transmission lines, the outer ground lines of the triplate can be adjusted  $\pm 5$  cm in most regions of the generator. This monitor accommodates this adjustment by allowing the high voltage electrode to slide on the rigid nylon tube. The extra length of tube is taken up inside the long cylindrical section of the electrode (see Figure 4). The change of fluid volume is compensated through a fitting at the tap-off end of the monitor. The length of the cylindrical section allows for  $\pm 5$  cm adjustment. By choosing different nylon tube lengths for each section of EAGLE, we are able to place a monitor in each required location.

### Calibration

The monitor is calibrated by discharging a capacitor into it. From the observed waveform and the known voltage on the capacitor, the division ratio and the resistance can be calculated using an exponential curve fit.

The monitor, after calibration out of the machine, is used to cross-calibrate capacitive monitors. For a check of both calibrations, a discrete resistor probe is inserted alongside the dividers and the line pulsed with an external

10 kV pulser. Waveforms from the resistive monitor and the discrete resistor probe are shown in Figure 5.

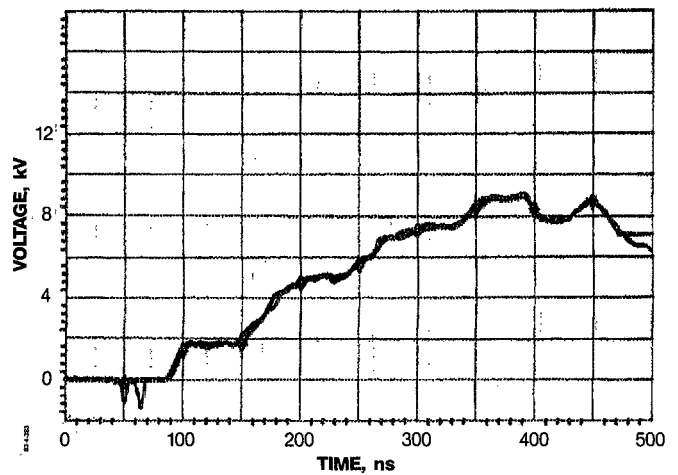

Figure 5. Overlay of signals from resistive monitor and discrete resistor probe.

### Performance

The monitor was in use in EAGLE for the entire testing period, and is planned to be used in Double-EAGLE. In the greater than 600 shots on EAGLE, we experienced two failures, both at the same location. We believe that these failures were caused by bubbles adhering to the external surface of the monitor. This location is the most difficult to see and sweep of bubbles, and the damage to the monitor is most severe at the place where bubbles would collect.

### Acknowledgements

The author would like to thank D. Pellinen and D. Osias for their suggestions during the electrical design of the monitor, and C. Parks and H. Gerbracht for their help in the mechanical design.

### References

1. D. Pellinen and S. Huerlin, Review of Scientific Instruments, Volume 42, Number 6, p. 824 (1971).
2. D. Pellinen, Q. Johnson, A. Mitchell, Review of Scientific Instruments, Volume 43, Number 2, p. 299 (1972).
3. D. Pellinen, M. Di Capua, Review of Scientific Instruments, Volume 51, Number 1, p. 70 (1980).
4. G.B. Frazier, et al., Proceedings of the 3rd IEEE International Pulsed Power Conference, p. 8 (June 1-3, 1981).