

IN-LINE PARTICLE FIELD HOLOGRAPHY AT PEGASUS

D.S. Sorenson, A. Obst, N.S.P. King, A J. Scannapieco, H. Lee, M. Sheppard, J. P. Roberts, D. Platts, A.J. Taylor, S. Watson, M. P. Hockaday.
Los Alamos National Laboratory, Los Alamos, NM, 87544

B. Malone, C. Ciarcia, B. Frogget
EG&G/EM, Los Alamos, NM 87544

D. Westley, R. Flurer, P. Watts, K. Peterson, B. Pritchett, D. Malson, D. Crain
EG&G/EM, Las Vegas, NV, 89125

Abstract

An in-line holographic imaging system has been developed for hydrodynamic experiments at the Pegasus facility located at Los Alamos National Laboratory. Holography offers the unique capability to record distributions of particles over a three dimensional volume. The system to be discussed is used to measure particle distributions of ejecta emitted after a cylindrical aluminum liner (5.0 cm in diameter, 2.0 cm high) impacts a target (3.0 cm in diameter). The ejecta emerge from the target traveling up to 7 mm/ μ s and moves toward the axial center of the system where the holographic imaging is performed. In-line holography is particularly suited for the Pegasus pulsed power facility where the geometry restrictions make off axis holography impractical. In order to record the fast moving particles a frequency-doubled Nd:-YAG laser system has been implemented which produces a 80 ps 20 millijoule pulse at 532 nm. An optical relay system composed of a Fourier optical lens pair has been developed which is placed 4.0 cm from the center of the region of interest. This relay lens pair forms an intermediate image 32 cm from the object plane and the hologram is placed 4 cm downstream from the intermediate image. The holographic system and resolution capability will be discussed.

I. Introduction

When a strong shock wave reflects from a surface, material can be emitted from the surface (ejecta). The amount of material and size of material particulates vary depending on many factors such as surface finish, and material type. This phenomena is not well understood. Many studies have been done to measure the amount of mass emitted from a shocked surface^{1,2}. Many of these measurements involve the use of a pick-up foil and Doppler Laser Interferometer techniques to measure the velocity of the foil and inferring the amount of mass. Other techniques to measure mass have involved using x-ray backlighters³, and time-dependent shadowgraphy. However, these mass measurements were not able to return information on particle size. Particle size information is critical in understanding how the particles propagate in gas. Currently, only a few holographic measurements of ejecta have been made⁴. In this report a holographic technique will be described which is being developed and applied to ejecta physics studies at the Pegasus pulsed power facility at Los Alamos National Laboratory.

II. Pegasus Pulsed Power Facility

Report Documentation Page

Form Approved
OMB No. 0704-0188

Public reporting burden for the collection of information is estimated to average 1 hour per response, including the time for reviewing instructions, searching existing data sources, gathering and maintaining the data needed, and completing and reviewing the collection of information. Send comments regarding this burden estimate or any other aspect of this collection of information, including suggestions for reducing this burden, to Washington Headquarters Services, Directorate for Information Operations and Reports, 1215 Jefferson Davis Highway, Suite 1204, Arlington VA 22202-4302. Respondents should be aware that notwithstanding any other provision of law, no person shall be subject to a penalty for failing to comply with a collection of information if it does not display a currently valid OMB control number.

1. REPORT DATE JUL 1995	2. REPORT TYPE N/A	3. DATES COVERED -	
4. TITLE AND SUBTITLE In-Line Particle Field Holography At Pegasus		5a. CONTRACT NUMBER	
		5b. GRANT NUMBER	
		5c. PROGRAM ELEMENT NUMBER	
6. AUTHOR(S)		5d. PROJECT NUMBER	
		5e. TASK NUMBER	
		5f. WORK UNIT NUMBER	
7. PERFORMING ORGANIZATION NAME(S) AND ADDRESS(ES) Los Alamos National Laboratory, Los Alamos, NM, 87544		8. PERFORMING ORGANIZATION REPORT NUMBER	
9. SPONSORING/MONITORING AGENCY NAME(S) AND ADDRESS(ES)		10. SPONSOR/MONITOR'S ACRONYM(S)	
		11. SPONSOR/MONITOR'S REPORT NUMBER(S)	
12. DISTRIBUTION/AVAILABILITY STATEMENT Approved for public release, distribution unlimited			
13. SUPPLEMENTARY NOTES See also ADM002371. 2013 IEEE Pulsed Power Conference, Digest of Technical Papers 1976-2013, and Abstracts of the 2013 IEEE International Conference on Plasma Science. Held in San Francisco, CA on 16-21 June 2013. U.S. Government or Federal Purpose Rights License.			
14. ABSTRACT An in-line holographic imaging system has been developed for hydrodynamic experiments at the Pegasus facility located at Los Alamos National Laboratory. Holography offers the unique capability to record distributions of particles over a three dimensional volume. The system to be discussed is used to measure particle distributions of ejecta emitted after a cylindrical aluminum liner (5.0 em in diameter, 2.0 em high) impacts a target (3.0 em in diameter). The ejecta emerge from the target traveling up to 7 mm/J.Ls and moves toward the axial center of the system where the holographic imaging is performed. In-line holography is particularly suited for the Pegasus pulsed power facility where the geometry restrictions make off axis holography impractical. In order to record the fast moving particles a frequency-doubled Nd:-Y AG laser system has been implemented which produces a 80 ps 20 millijoule pulse at 532 nm. An optical relay system composed of a Fourier optical lens pair has been developed which is placed 4.0 em from the center of the region of interest. This relay lens pair forms an intermediate image 32 em from the object plane and the hologram is placed 4 em downstream from the intermediate image. The holographic system and resolution capability will be discussed.			
15. SUBJECT TERMS			
16. SECURITY CLASSIFICATION OF:			17. LIMITATION OF ABSTRACT
a. REPORT unclassified	b. ABSTRACT unclassified	c. THIS PAGE unclassified	SAR
			18. NUMBER OF PAGES 6
			19a. NAME OF RESPONSIBLE PERSON

The Pegasus facility at LANL is a pulsed power machine which dumps current through an aluminum cylinder (5 cm in diameter by 2 cm in height). The electric and magnetic forces implode the cylinder symmetrically to velocities of 4 mm/ μ s. The target assembly showing the aluminum cylinder (aluminum liner) is shown in the top left region of Fig. 1. At some point during the implosion phase the liner impacts the target cylinder (see Fig. 1) where a 300 kbar shock is set-up in the target. As the shock breaks out from the inner surface of the target, ejecta is formed and emitted from the surface at velocities up to 7 mm/ μ s. The size and velocity of the ejected mass is a function of many parameters, such as surface finish, material type and shock pressures. As the ejecta moves toward the center of the cylindrical axis an inner cylinder(collimator) with various slits allows just a small portion of the ejecta to enter into the region where the holographic measurements are made. In order to record the fast moving particles a frequency-doubled Nd:-YAG laser system has been developed which can be externally triggered with less than 10 ns jitter and which produces an 80 ps 20 millijoule pulse at 532 nm. The spatial quality of the laser beam is improved by using a vacuum spatial filter. As Fig. 1 shows, the laser pulse passes axially through the load assembly where the beam is diverging so as to cover a 1.5 cm diameter. After the beam passes through the region where the particles reside, part of the beam is diffracted and the rest passes through the region unscattered (reference beam).

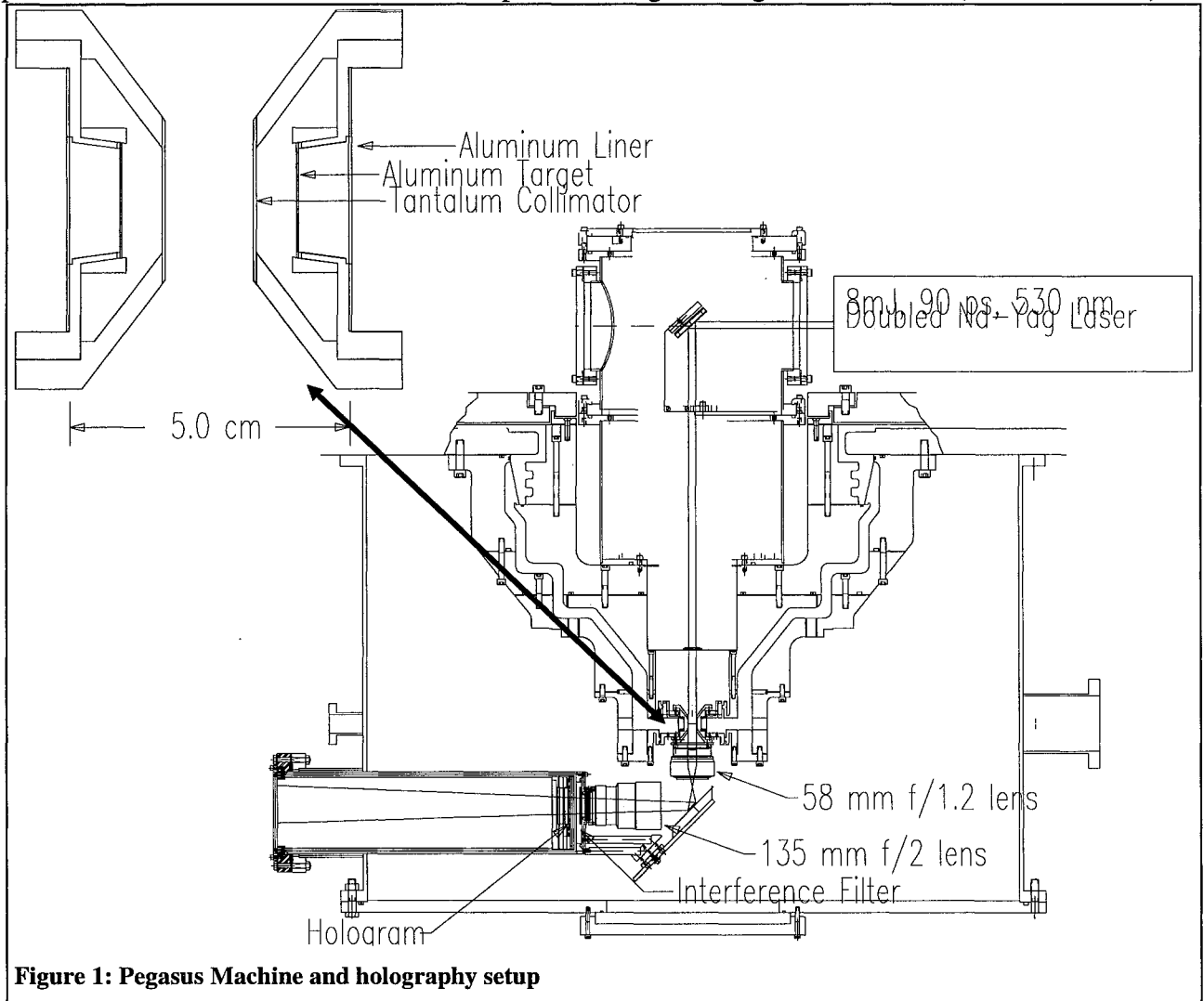

Figure 1: Pegasus Machine and holography setup

A Fourier optical lens pair is placed 4.0 cm from the center of the region of interest. This relay lens pair forms an intermediate image 32 cm from the object plane. The hologram is then placed in a steel cylinder which is inserted into the PEGASUS vacuum chamber where the hologram is 36 cm from the object plane.

III. In-line Fraunhofer Holography

Off-axis holography is the most common technique used to make holograms. However, there are certain situations where in-line Fraunhofer holography is more practical. In-line holography is particularly suited for the Pegasus pulsed power facility where the geometry restrictions make off axis holography difficult to implement. Fig. 2 illustrates the off-axis and in-line holography methods. In both cases a reference beam and scattered beam interfere to form the interference pattern on the holographic film. The in-line approach has the advantage that a separate reference beam path is not needed. A disadvantage of the in-line approach is that the transmission of the beam through the particles of interest must be kept high so that enough reference beam will make it through the particles and interfere with the scattered light. Presently, the transmission has been kept above the 95% level. Many detailed studies have been done describing the theory of in-line Fraunhofer holography⁵. Here I present some of the results. The irradiance distribution for an opaque sphere a distance z_0 from the particles is given by⁵:

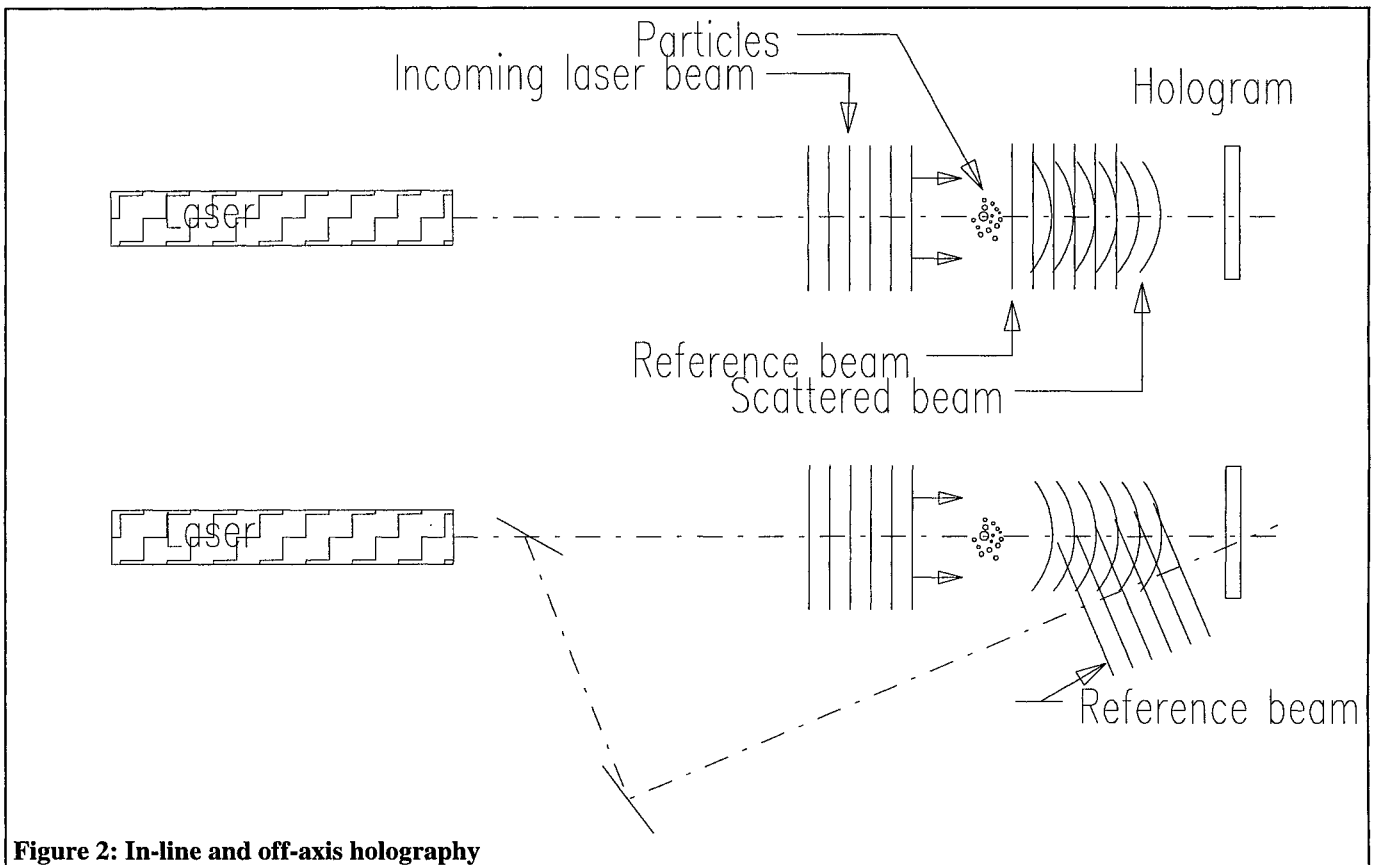

Figure 2: In-line and off-axis holography

$$I(x',y') = \left(\frac{B}{m_o}\right) \left\{ 1 - \frac{2m_o\pi a^2}{\lambda_o|z_o|} \times \sin\left(\frac{\pi r'^2}{m_o\lambda_o|z_o|}\right) \left[\frac{2J_1\left(\frac{2\pi a r'}{\lambda_o|z_o|}\right)}{\frac{2\pi a r'}{\lambda_o|z_o|}} \right] + \left(\frac{m_o\pi a^2}{\lambda_o|z_o|}\right)^2 \left[\frac{2J_1\left(\frac{2\pi a r'}{\lambda_o|z_o|}\right)}{\frac{2\pi a r'}{\lambda_o|z_o|}} \right]^2 \right\} \quad (1)$$

where x', y' are the coordinates in the plane of the irradiance distribution and $r' = x'^2 + y'^2$. The magnification is given by m_o , λ_o is the wavelength of the laser light, and $2a$ is the diameter of the particle. Fig. 3-5 show the irradiance distribution for the case where $z_o = 4$ cm. In our system our first collecting lens is placed 4 cm from the object plane. Note that the size information ($2a$) is contained in the envelope function and not the high frequency oscillations. At a minimum, the first lobe needs pass through the first collecting lens in order to determine the size of the particle. Fig. 3 shows the irradiance distribution for a 1 micron diameter sphere. The figure shows that an area with a diameter of 5 cm is required to record the first lobe. Fig. 4 shows that a 2.6 cm diameter field is needed to record the first lobe for a 2 micron diameter particle, and Fig. 5 indicates only a 1cm diameter field is needed to record the first lobe of a 5 micron diameter sphere. One can see that in order to record the necessary information for the smaller particles an optical relay system with a large solid angle or small F# is necessary. The current system can record between 1 and 2 micron diameter particles.

IV. Holographic reconstruction

Once a hologram has been made an enormous amount of data exists which must be analyzed. The analysis will be described in this section. Fig. 6 shows the system used to acquire images from the hologram. A He-Ne laser is used and a spatial filter and collimating lens is used to condition the beam. As the laser beam passes through the hologram a real image is formed downstream of the hologram and a virtual image is formed upstream of the hologram. The real image is magnified and relayed to the volume element shown in the figure. A Videx Megaplus CCD camera is used to capture the image. The camera uses a CCD chip 1320 by 1035 pixels where each pixel is $6.8 \mu\text{m}$ by $6.8 \mu\text{m}$. The analysis is divided into three steps. The first step is to acquire

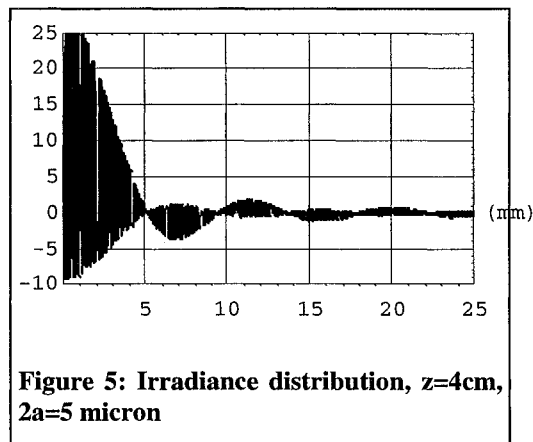
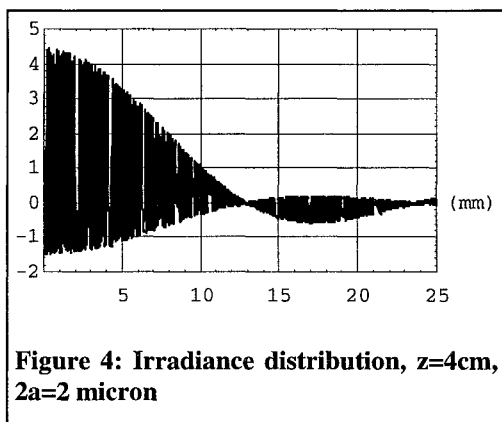
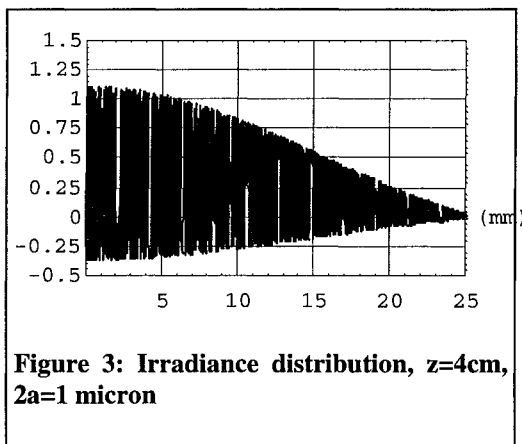

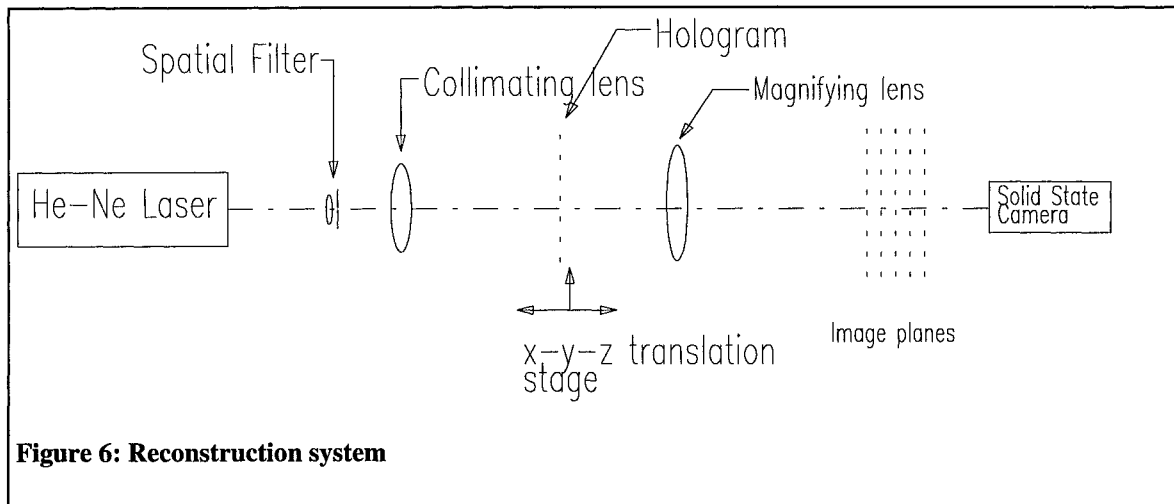

Figure 6: Reconstruction system

the data. This is done by a program which controls the three-dimensional stage and the camera readout. Images are acquired and stored to disk. Many hundreds or thousands of images are acquired. The next step is to analyze the images. This is done by first modeling the background for the data sets. The background image models the low frequency part of the image (see Fig. 7). If the background is subtracted the top image in Fig. 8 results. Once the background has been determined a thresholding procedure is used to tag possible candidates and a binary segmented image is constructed. This is shown at the bottom of Fig. 9. After a binary segmented image is created a correlation is done for image planes ahead and behind the possible particle to determine if the candidate is indeed going in and out of focus. If this condition is met the candidate is

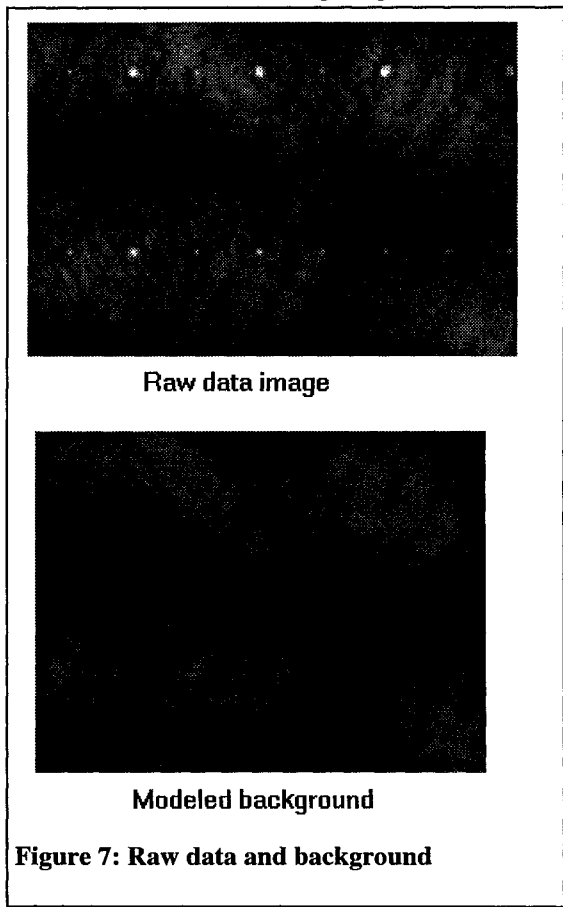

Figure 7: Raw data and background

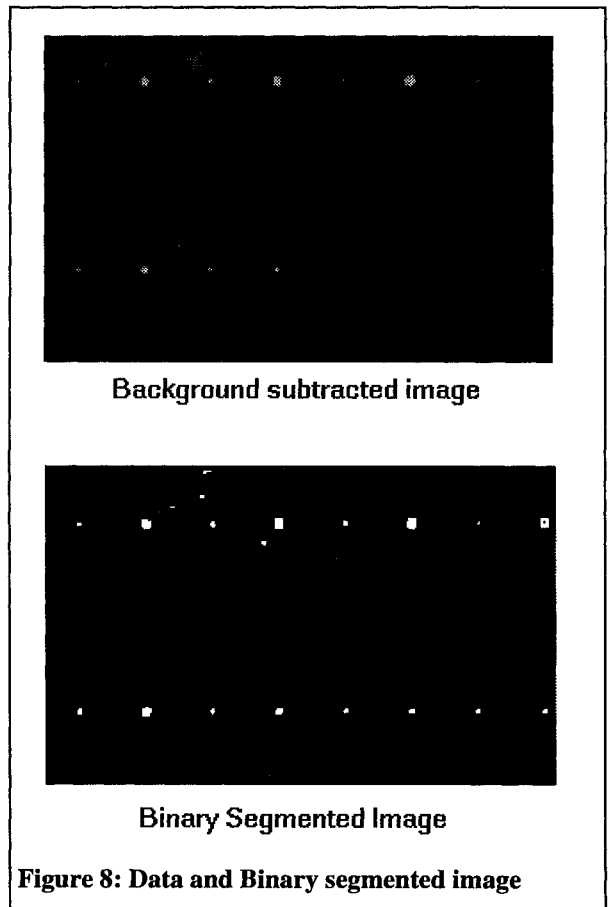

Figure 8: Data and Binary segmented image

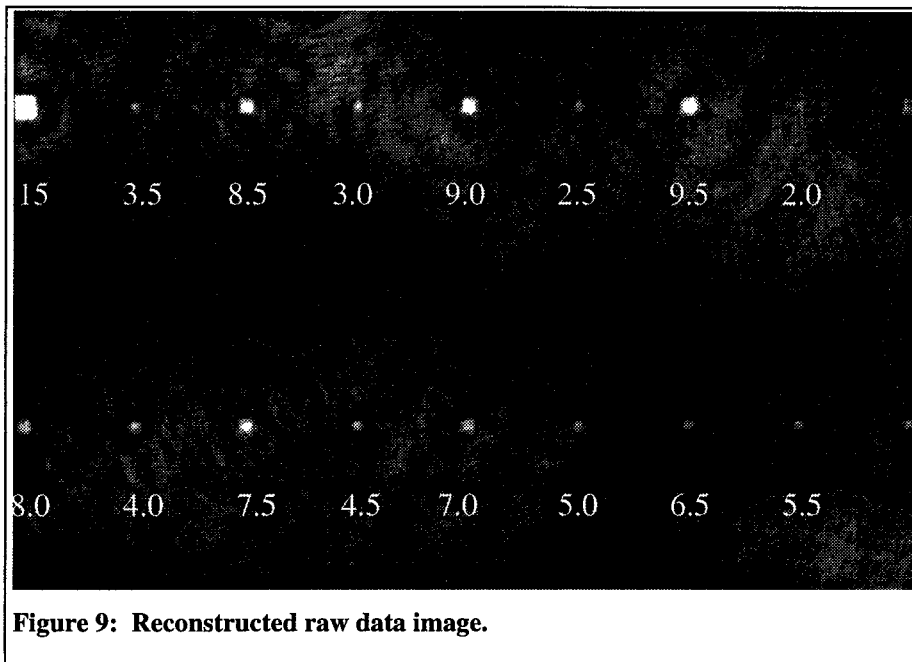

Figure 9: Reconstructed raw data image.

tagged as a particle. Finally, the particles are analyzed for their properties such as average area. The particle location, and size are then written out to a file. Once the reconstructed images have all been analyzed the output file can then be used to create particle distribution plots. In determining the resolution of the system a glass plate was made up with black dots and squares of

known sizes. Holograms were then made using the optical relay system as designed for the pulse power experiments. Fig. 9 shows a reconstructed hologram of the resolution pattern. The image plane is in focus and the 2.0 micron square can be observed. The actual shape can be resolved for the larger squares, but for the smaller squares the shape gets blurred. This is due to the resolution of the lens system. Higher resolution optics are currently being designed.

V. Conclusions

An in-line Fraunhofer holographic imaging system has been described which is being fielded at the Pegasus pulsed power facility at LANL. A high energy short pulsed laser system is required to make the holograms and this laser system has been described. The system has been fielded and has worked as expected. Resolution requirements have required a high quality optical transfer system with a large solid angle in order to achieve resolutions between 1 and 2 microns. The system is currently undergoing improvements. In particular, background and shape definitions should improve as the optical relay system improves. Plans are underway to field the diagnostic to measure ejecta for various target finishes ranging from a submicron deep pits to 50 micron deep pits. These studies will allow particle size distributions to be obtained, which will be compared to theoretical models.

¹ P. Andriot, P. Chapron, V. Lambert, F. Olive, "Influence of Melting on Shocked Free Surface Behavior using Doppler Laser Interferometry and X-ray Densitometry", Shock Waves in Condensed Matter, Elsevier Science Publishers B.B., (1983).

² J.R. Assay, "Material Ejection From Shock-Loaded Free Surfaces of Aluminum and Lead", Sandia Laboratories Report SAND 76-0542 (1976) (unpublished).

³ P. Elias, P. Chapron, M. Mondot, "Experimental study of the slowing down of shock-induced matter ejection into argon gas". Shock Compression in Condensed Matter 1989, Elsevier Science Publishers B.B., (1990) 783-786.

⁴ C. McMillan, R. Whippley, Proceedings 18th International Congress on High-Speed Photography and Photonics Xian, China (1988).

⁵ Chandra S. Vikram, Particle Field Holography, Cambridge Studies in Modern Optics (1992).