

# Large Area, High Reliability Liquid Dielectric Systems: Provisional Design Criteria and Experimental Approaches To More Realistic Projections\*

I. Smith, D. Weidenheimer, D. Morton  
Titan Pulse Sciences Division  
San Leandro, CA 94577

L. Schlitt  
Leland Schlitt Consulting Services  
Livermore, CA 94550

J. Sethian  
Naval Research Laboratory  
Washington, DC 20375

## I. INTRODUCTION

In the Electra program a number of candidate designs have been developed for pulsed power systems to drive KrF lasers in an inertial confinement fusion power plant [1,2]. All use coaxial  $\sim 1.5$  MV water energy stores and oil insulation; most use oil-insulated magnetic switches. The largest design, a three-stage magnetic pulse compressor, is illustrated in Fig. 1, where the regions of highly-stressed electrodes in the water and oil are indicated. There will be of the order

first tests will be on oil. We will be able to test only  $\sim 10^4$  cm<sup>2</sup> of electrode compared with  $\sim 10^8$  cm<sup>2</sup> in the power plant, and even if we are able to accelerate testing to 200 pps, a single  $3 \times 10^8$  pulse run would require approximately two months of testing; therefore the design of the power plant modules will remain a large extrapolation. The Electra program will progressively eliminate the uncertainties associated with this extrapolation by constructing large and full-scale prototype modules. Still, there is much we can do in the immediate planned testing to reduce the

Plan View

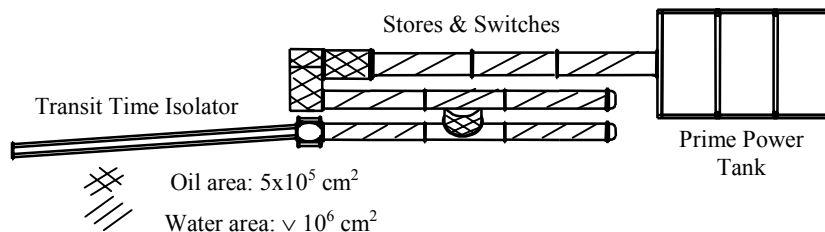

Figure 1. Baseline pulse power module for the KrF laser fusion plant – Electra program.

of 200 such modules in a power plant. It is important to minimize the size and cost of the module hardware by designing for the highest safe electric fields. The oil area, though smaller than the water, is at least as important because there is a proportionate volume of Metglas switch material, which is not only expensive but dissipates a certain energy loss per unit volume; and electrical efficiency, like cost, is critical.

The pulse power must operate for at least two years between failures, and at 5-10 pps this represents about  $3 \times 10^8$  shots. The combination of large areas and high required reliability makes the design a very large extrapolation from experience. To reduce the uncertainties, we are planning tests in the Electra program, using an existing “Rep-SLIA” modulator [3] and a 450 kV pulse transformer that will be able to operate at up to 200 pps and a power of  $\sim 100$  kW. The

uncertainties and justify the design criteria we have provisionally adopted for the power plant modules, and to help design prototypes. In this paper we discuss uncertainties in three areas; reliability over many pulses, extrapolation to large areas, and factors that may increase or decrease the safe fields. Then we show the design of the oil test hardware that we are planning based on these considerations.

## II. STATISTICS OF LARGE PULSE NUMBERS

We want the pulse power system to break down no more often than every  $N = 3 \times 10^8$  pulses, and (neglecting for now effects of rep-rate, conditioning, etc.) we must ask what fraction ( $f$ ) of single-pulse breakdown corresponds to this. One answer found in the literature is to choose  $f = (N/2)^{-m}$ , where  $m$  is the slope of the area dependence of single-pulse breakdown (Fig. 2) so that the probability of

\*Work supported by The Naval Research Laboratory.

# Report Documentation Page

*Form Approved*  
*OMB No. 0704-0188*

Public reporting burden for the collection of information is estimated to average 1 hour per response, including the time for reviewing instructions, searching existing data sources, gathering and maintaining the data needed, and completing and reviewing the collection of information. Send comments regarding this burden estimate or any other aspect of this collection of information, including suggestions for reducing this burden, to Washington Headquarters Services, Directorate for Information Operations and Reports, 1215 Jefferson Davis Highway, Suite 1204, Arlington VA 22202-4302. Respondents should be aware that notwithstanding any other provision of law, no person shall be subject to a penalty for failing to comply with a collection of information if it does not display a currently valid OMB control number.

1. REPORT DATE <b>JUN 2001</b>		2. REPORT TYPE <b>N/A</b>		3. DATES COVERED <b>-</b>	
4. TITLE AND SUBTITLE <b>Large Area, High Reliability Liquid Dielectric Systems: Provisional Design Criteria and Experimental Approaches To More Realistic Projections</b>				5a. CONTRACT NUMBER	
				5b. GRANT NUMBER	
				5c. PROGRAM ELEMENT NUMBER	
6. AUTHOR(S)				5d. PROJECT NUMBER	
				5e. TASK NUMBER	
				5f. WORK UNIT NUMBER	
7. PERFORMING ORGANIZATION NAME(S) AND ADDRESS(ES) <b>Titan Pulse Sciences Division San Leandro, CA 94577</b>				8. PERFORMING ORGANIZATION REPORT NUMBER	
9. SPONSORING/MONITORING AGENCY NAME(S) AND ADDRESS(ES)				10. SPONSOR/MONITOR'S ACRONYM(S)	
				11. SPONSOR/MONITOR'S REPORT NUMBER(S)	
12. DISTRIBUTION/AVAILABILITY STATEMENT <b>Approved for public release, distribution unlimited</b>					
13. SUPPLEMENTARY NOTES <b>See also ADM002371. 2013 IEEE Pulsed Power Conference, Digest of Technical Papers 1976-2013, and Abstracts of the 2013 IEEE International Conference on Plasma Science. IEEE International Pulsed Power Conference (19th). Held in San Francisco, CA on 16-21 June 2013. U.S. Government or Federal Purpose Rights License, The original document contains color images.</b>					
14. ABSTRACT					
15. SUBJECT TERMS					
16. SECURITY CLASSIFICATION OF:			17. LIMITATION OF ABSTRACT	18. NUMBER OF PAGES	19a. NAME OF RESPONSIBLE PERSON
a. REPORT <b>unclassified</b>	b. ABSTRACT <b>unclassified</b>	c. THIS PAGE <b>unclassified</b>			

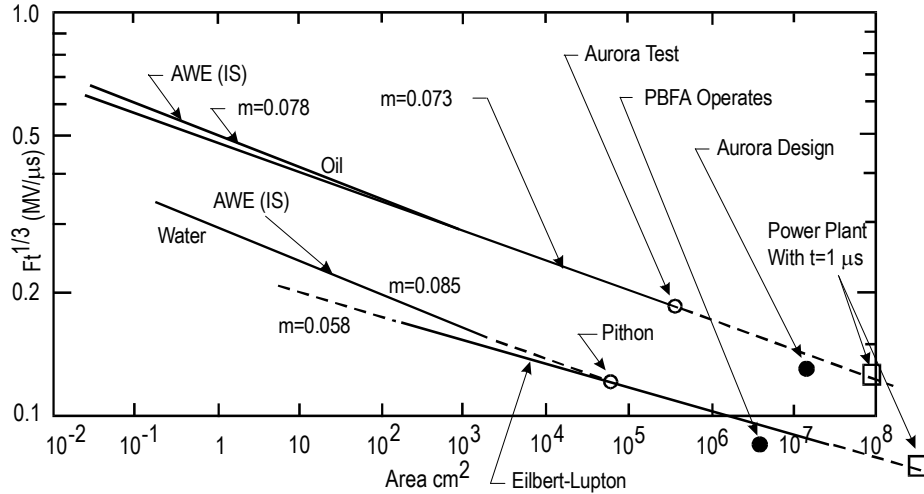

Figure 2. Area effect.

breakdown on a single pulse is  $1/N$ . This answer would be valid if we changed to a new area every pulse, so that the area tested moved steadily to the right in Fig. 2 until we encountered breakdown at a low fraction  $f$  on the tail of the probability distribution. But if we do not change the sample every pulse but keep testing the same one we probably eliminate a source of variation and narrow the probability distribution. The result  $f = (N/2)^{-m}$  would be correct only if the area effect is entirely due to shot-to-shot variation and all areas of the same size are completely indistinguishable. It seems more likely that sample-to-sample variation as well as shot-to-shot variation contributes to the area effect, and the question is what is the proportion of the two effects. We hope to determine this, at least for  $\sim 10^4 \text{ cm}^2$  areas, by experiment.

Figure 3, constructed from the data in Ref. 3 further illustrates this question and how it might be tested. For a  $100 \text{ cm}^2$  electrode area in water, the stress corresponding to 10% breakdown probability is determined as a function of the number of pulses. Fig. 3 plots  $Ft^{1/3}$  against number of shots in the same way as we plot it against area in Fig. 2. Because the  $t_{\text{eff}}$  is rather more than 1 usec, the time dependence is likely to be weaker than  $t^{1/3}$ , so we also plot  $Ft^{1/6}$ . The slopes are 0.039 (for  $t^{1/3}$ ) and 0.027 ( $t^{1/6}$ ). The average, 0.033, is about half what we would expect for the area effect in this area range (see Fig. 2 and the next section).

Provisionally, our design of the power plant modules assumes that while the area effect may continue to the power plant area with the reported slope exponent  $-m$ , the shot-to-shot variation has a probability distribution similar to that giving rise to the area effect, but with half the variation, which corresponds to an exponent  $m/2$ . For  $3 \times 10^8$  pulses between breakdown our assumption allows design at 49% of breakdown,

whereas using the full value of  $m$  would require 24% ( $0.49^2$ ). This comparison shows the importance of the distinction.

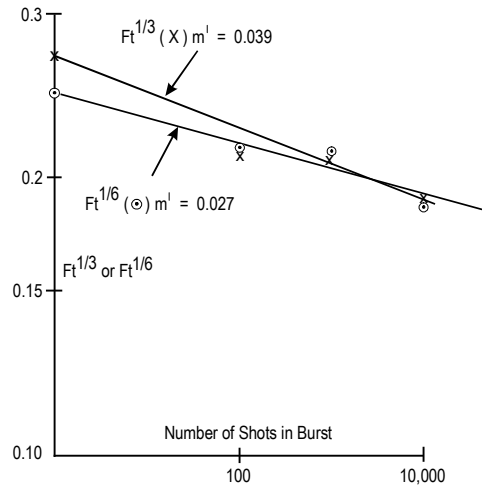

Figure 3.

### III. BREAKDOWN AT LARGE AREAS

In Fig. 2 we see the area effects proposed for oil and water plotted in terms of  $Ft^{1/3}$  and extended to the area of the power plant. The full lines are in regions where there is data. The results initially proposed by I. Smith at AWE [5] are also shown. In the case of oil, the AWE exponent was changed little when taking into account larger area data obtained later; this data included the largest dedicated test, a  $300,000 \text{ cm}^2$ ,  $\sim 4 \text{ MV}$  coax studied in the Aurora program. For water, Smith found  $Ft^{1/3} = 0.28 A^{-0.085}$ , but Eilbert and Lupton (EL) [6] suggested  $0.23 A^{-0.058}$  was better justified, at least for large areas, and their result is generally used. The

largest data point shown for water comes from a previously unpublished test in which the coaxial PFL of the PI-DNA PITHON generator was driven well above its design level in initial tests aimed at determining the breakdown limit. Essentially at the stress indicated by EL, breakdowns occurred in the PFL; these may have occurred in post switchout ringing rather than during charge, but they were taken to indicate that the PFL was close to breakdown and to at a safe operating level.

The power plant modules have a number of different fields and  $t_{\text{eff}}$  values, some of the latter exceeding 1  $\mu\text{sec}$ , but because time dependence may be weaker than  $t^{1/3}$  in this range we take  $t_{\text{eff}} = 1 \mu\text{sec}$  as a representative value. The corresponding breakdown fields indicated on Fig. 2 for the power-plant areas are 125 kV/cm for oil and 75 kV/cm for water; if these are correct we must plan to operate at half these fields.

J.C. Martin's well-known formula for the breakdown in water of a sharp exposed needle to a plane,  $Ft^{1/2} = 0.09$ , often predicts higher breakdown fields for large areas than does EL. In this case it predicts a breakdown field of 90 kV/cm rather than the 75 kV/cm given by EL. Moreover, since any sharp pointed defect present will be shielded to some extent by the large electrodes, the actual breakdown field should be even higher. It is usually assumed that the explanation for such a discrepancy in predictions is that the area dependence departs from EL and in effect disappears at some large area. However, the area at which this transition occurs is purely a matter of speculation. Here we suggest that this disagreement between the EL and point-plane formulas points to a way to develop an engineering criterion for large areas to replace the area effect prediction: viz., if we can exclude streamer initiation points bigger or sharper than some level, it will be safe to operate at some corresponding field, no matter what the area.

The validity of such a criterion implies that for areas greater than some value breakdown is always the result of some identifiable type of defect or solid conducting contaminant. The  $3 \times 10^5 \text{ cm}^2$  Aurora test usually broke at locations where contaminants lighter or heavier than oil would rest. In the PITHON water test at 100% of EL, an arc originating at a switch illuminated a number of solid contaminants resting on the positive outer conductor, of which some had grown long streamers, (Fig. 4); on another shot with a stress a few percent lower, one such streamer closed.

A crude analysis can illustrate such a criterion. In the case of oil, the point-plane result takes the form of a mean streamer velocity found experimentally to be  $u = 90 V^{1.75}$  where a gap  $d$  closes in a time  $t$  under a voltage  $V(\text{MV})$  and  $u = d/t$ . If we make the crude assumptions that  $u$  actually depends on the field at the

streamer tip  $V/s$  where  $s$  is a distance characteristic of the streamer shape; that in a field  $F$  the expression  $F(1 + x/s)$  gives both the field at the tip of a defect extending a distance  $d = x$  from a plane electrode and the field at the tip of a streamer when the streamer is at a distance  $x$ ; and that the breakdown is  $Ft^{1/3} A^{0.075} = 0.48$ ; and if we allow the possibility of a threshold field for streamer formation, we can obtain the height of a defect required to account for breakdown

$$d + s > 0.2 A^{-0.175} t^{0.42} \text{ (cm) .}$$

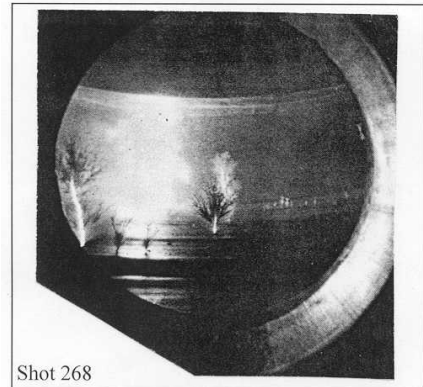

Figure 4. Pithon PFL over-voltage test at 99% of EL criterion,  $Ft^{1/2} = 0.11$ .

This suggests that the Aurora test coax was limited by particles at least about 2 mm in size; and that the area effect in Fig. 2 will extend to the much larger areas of the power plant only if the plant includes contaminants up to at least 5 mm in size. But if procedures can exclude contaminants larger than (say) 1 mm, the predicted power plant breakdown field increases from 125 to 240 kV/cm. This analysis is too crude to be a quantitative basis for design, and ignores statistics; but if experiments can correlate contaminant size and type with breakdown stress a useful criterion of the same type might result.

#### IV. FACTORS THAT MAY AFFECT SAFE STRESS

Reference 4 indicates that the breakdown of water is independent of rep-rates up to 100 pps, and Stangenes (private communication) has said that rep-rates around 10 pps can be ignored in designing oil-immersed transformer output terminals; he appears to design these near single-pulse breakdown levels. Thus the rep-rate of the power plant *per se* may not affect insulation.

A separate question is whether the Electra tests can use rates up to 100-200 pps to accelerate data collection. With fields of  $\sim 200 \text{ kV/cm}$  and pulse durations of a microsecond, rms fields would be a few kV/cm.

I. Smith found at AWE that dc fields reduced the impulse strength of oil, with a reduction of 50% at 3 kV/cm dc. This was attributed to movement and alignment of impurities under the dc field. (Later, at PI,

this effect led to balance-charging of Marxes; this kept capacitor cases at dc ground and reduced breakdown to ground under Marx pulse voltage.) RMS fields of the same value may produce the same effects. Better oil purity or oil flow may reduce any such effect. But in any case, care must be taken to ensure that data is not taken at rep-rates that change the results from those at 10 pps.

G. Rohwein (private communication) has indicated that build-up over millions of pulses of dissolved gas produced by corona eventually degrades the repetitive strength of oil, and occasional or continuous degassing is needed to avoid this. Similarly, resistive heating of water will require modest cooling over long runs.

Possible ways to improve the repetitive breakdown of oil and water include moderate pressure (P. Garner, BAE, private communication), vacuum impregnation, and plastic coating of electrodes. Electrode coating produces only ~10% improvement single-pulse, and does not seem promising for long term operation because plastics are not self-healing. The possibility of conditioning by prolonged operation below breakdown is of interest, especially in water where partial discharges can deliver more energy to remove defects that initiate them, but even in oil; the large Aurora coax showed evidence of conditioning when subjected to reliability testing. Beneficial conditioning by complete breakdown does not seem likely in the power-plant modules because of their ~100 kJ energies; in the Electra tests it is unclear whether breakdowns will condition or require repair of electrode surfaces.

Polarity effects must also be investigated. It will be very beneficial to be able to design enhanced negative inner conductor regions of power-plant modules at higher fields where possible. In the single-pulse breakdown of water the polarity effect has always been reported as about 2:1; it must be characterized for repetitive operation. Polarity effect must also be characterized for oil, where in single-pulse breakdown it varies with configuration in a way that is not understood. Pipe-over-plane tests in the Aurora program, with ~10<sup>4</sup> cm<sup>2</sup> of pipe at 4-5 MV showed polarity effects from about 1.5 up to almost 2, Fig. 5(a). AWE tests with smaller areas and lower field enhancement gave smaller values; and in the Aurora large coax test one breakdown clearly appeared to originate at the negative outer electrode where the field was 10% less than that at the positive inner, Fig. 5(b).

## V. ELECTRA TEST CONFIGURATION

Figure 6 illustrates the planned Electra oil test configuration. The transformer can give 450 kV, ~1 μsec pulses of both polarities. The coaxial modules √1 m long and ~5 cm in diameter constitute the largest area test. They have inner conductors half the radius of the outer in order to address polarity effect. Inner con-

ductors are supported at both ends on diaphragms, designed with low fields, that allow pressurization and control of the oil conditions within the coax, independent of the transformer oil-volume. The coaxes can easily be detached for examination or re-work. There is a resistive load that removes the voltage on each pulse without switching, making the almost-unipolar waveform reproducible and operation easy. Other resistors isolate individual coaxes from one another to limit energies deposited in breakdowns.

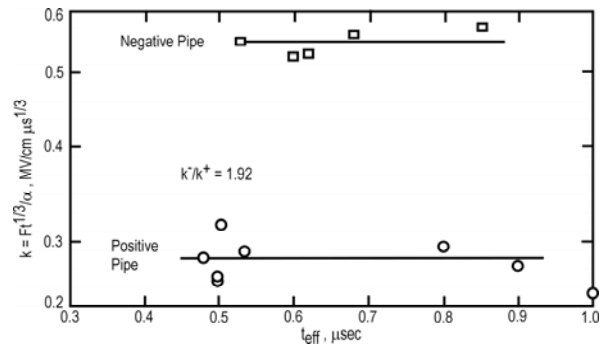

Figure 5(a). Oil polarity effect in 4-5 MV 10<sup>4</sup> cm<sup>2</sup> Aurora tests.

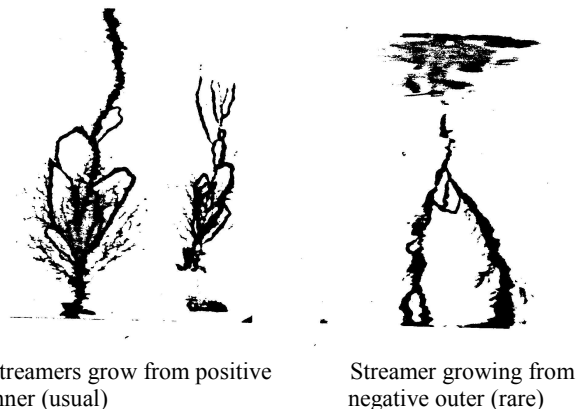

Figure 5(b). Oil breakdowns in Aurora test coax; spacing 7-1/4 inches, positive electrodes are at bottom.

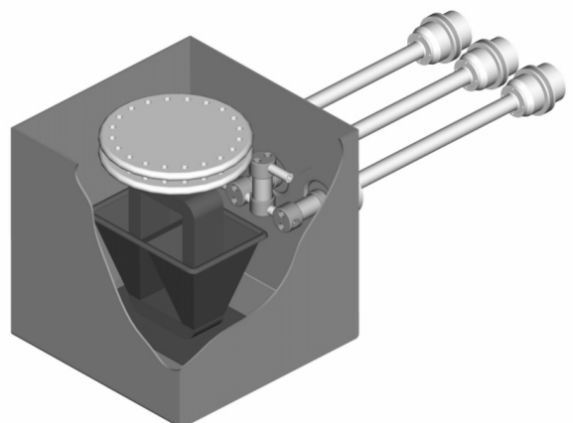

Figure 6. Electra oil test configuration.

Above the transformer Fig. 6 shows a smaller parallel plate oil-test volume into which defects of controlled size, shape, and sharpness can be introduced that will rest against the sensitive-polarity electrode. The defects will be of the types that might be present in practice, such as welding and machining debris and bubbles. This test region is also sealed separate from the main tank, and may be used for initial water tests too.

Tests are expected to start this autumn.

#### REFERENCES

[1] J.D. Sethian, et al., "The Electra KrF Laser Program", this conference.

[2] D. Weidenheimer, et al., "The Electra Repetitive Pulsed Power Design, Results and Advanced Studies," Proc. of 24th Power Modulator Symposium, Norfolk, VA, pp. 29-34.

[3] S.D. Putnam, et. al., "The Proof-of-Concept Experiment for the Spiral Line Induction Accelerator", Section 5 Rep-SLIA, PSIFR-2537, February 1999, Contract No.: N60921-89-C-0100.

[4] G. Simcox, et al., "Dielectric Performance Under Repetitive Electrical Stresses", PIFR-1297, 9/79.

[5] I. Smith, "Impulse Breakdown of De-Ionized Water" (11/16/65); "Further Breakdown Data Concerning Water; and Breakdown of Transformer Oil" (10/11/66) AWE Notes, collected in AFWL Dielectric Strength Notes.

[6] Eilbert and Lupton, "Extrapolating AWE Water Breakdown Data," NRL Note ca. 1968.