

K. F. McDonald, F. Mako, T. Smith, L. Floyd,  
J. Golden and C. A. Kapetanakos

Plasma Physics Division  
Naval Research Laboratory, Washington, D. C., 20375-5000

### Summary

The purpose of this article is to describe the pulsed power components of NRL's Modified Betatron Accelerator (MBA). The MBA has the design goal to produce multikiloampere electron beams with peak energy of ~50 MeV. This accelerator comprises several pulsed power subsystems: the betatron and toroidal magnetic fields, a precision 1.25 MeV, 10 kA injector and auxiliary electromagnets to facilitate beam capture. The magnets have been designed to produce fields with low temporal and spatial errors < 1% and are powered by capacitor bank discharge. The injector generates pulses [ $< 20$  nsec risetime and falltime, 20 - 30 nsec flat-top] having ripple < 1% and shot-to-shot variation < 1.5%. An experiment to study injection and beam trapping into the 1 m radius vacuum chamber is underway.

### Introduction

NRL's Modified Betatron Acceleration (MBA) is a compact cyclic induction accelerator designed to produce a 50 MeV, 5 - 10 kA electron beam [1]. The MBA utilizes a strong toroidal magnetic field to allow the acceleration of much higher current beams than are achievable with conventional betatrons [2]. The present experiment on the MBA investigates internal injection and confinement of a 1 MeV, 1-3 kA electron beam [3,4]. A subsequent experiment will study acceleration.

The pulsed power systems that drive the accelerator are described in this paper. These systems power the magnets that produce the betatron (BF) and toroidal (TF) magnetic fields, the trimmer magnets that adjust the magnetic flux and field index, the coils that produce an initial field offset that results in beam capture, and an injection accelerator.

The electron beam is injected near the wall of the toroidal vacuum chamber (Fig. 1). Acceleration results from the time varying betatron magnetic field that produces an inductive electric field. The two main beam motions are a fast oscillation around the major axis and a slow drift around the beam equilibrium position. The mean radial position of the orbit is the equilibrium radius  $r_e$  [5].

The betatron field (BF) must be "matched" to the relativistic beam energy to avoid a large displacement of  $r_e$  [1-5]. Thus, the correct BF amplitude must be obtained within 1%. Additional requirements are: (1) azimuthal uniformity, (2) providing the correct field index, and (3) maintaining the betatron flux condition [2]. The acceleration time is the BF pulse risetime which is 3 msec.

### Betatron Field

The BF coils produce magnetic fields with < 1% dynamic spatial variation [6]. Low field errors are achieved by: (1) coil stiffness to minimize deflections, (2) linear to coaxial connections as the lead from each coil to the coaxial buswork, and (3) minimizing eddy currents in the support structure by using fiberglass reinforced plastic and stainless steel composite components that have a short magnetic diffusion time. The coils are mechanically aligned to within 3 mm. The betatron field coil set is composed of 18 series connected coils (10 single turn coils and 2 four turn coil sets) (Fig. 2). BF inductance is about 530  $\mu$ H and the field energy is 0.6 MJ at 1.8 kG (45 kA).

The betatron field capacitor bank has precise charging and triggering to produce current waveform amplitudes accurate to within 0.5%. The BF power supply charges the bank in one minute to a voltage (17 kV, 2.5 A max) that is selectable to within 0.2%. The required precision is maintained for a period as long as two minutes after the charging process has been completed. The bank utilizes ignitron switches that are triggered by Krytron firing circuits.

Presently, an interim version of the BF bank powers the coils. However, by next year, the BF bank will have a stored energy of 2.2 MJ and will deliver 45 kA to the BF coils and 5 - 10 kA to each of three sets of parallel BF trimmer coils that adjust field index and the flux. The BF bank design philosophy is identical to that of the toroidal field bank which is described in detail in the next section.

### Toroidal Field

The toroidal field (TF) is "matched" to the transverse emittance of the beam to minimize the amplitude of radial oscillations of the beam envelope. The TF must also have uniformity, precision and reproducibility. Ample access to the vacuum chamber is obtained by using TF coils that are much larger than the vacuum chamber and have a large space between adjacent coils. The use of a louvered high current density (3 kA/cm) contact material (Hugin spring joint) [7] permits removal of the outer vertical TF coil segment and produces a low resistance joint with low bolting forces.

The toroidal field coil configuration consists of 12 series connected rectangular coils with vertical segments centered at radii of 40 cm and 175 cm and radial segments at 75 cm off the midplane (Fig. 2,3). The TF inductance is ~85  $\mu$ H and the field energy is 2 MJ at 5 kG (210 kA).

The toroidal field capacitor bank is designed to store 3.5 MJ of energy. The complete air insulated bank comprises 144, 396  $\mu$ F capacitors, each

# Report Documentation Page

*Form Approved*  
*OMB No. 0704-0188*

Public reporting burden for the collection of information is estimated to average 1 hour per response, including the time for reviewing instructions, searching existing data sources, gathering and maintaining the data needed, and completing and reviewing the collection of information. Send comments regarding this burden estimate or any other aspect of this collection of information, including suggestions for reducing this burden, to Washington Headquarters Services, Directorate for Information Operations and Reports, 1215 Jefferson Davis Highway, Suite 1204, Arlington VA 22202-4302. Respondents should be aware that notwithstanding any other provision of law, no person shall be subject to a penalty for failing to comply with a collection of information if it does not display a currently valid OMB control number.

1. REPORT DATE <b>JUN 1985</b>	2. REPORT TYPE <b>N/A</b>	3. DATES COVERED <b>-</b>	
4. TITLE AND SUBTITLE <b>The NRL Modified Betatron Accelerator Pulsed Power Systems</b>		5a. CONTRACT NUMBER	
		5b. GRANT NUMBER	
		5c. PROGRAM ELEMENT NUMBER	
6. AUTHOR(S)		5d. PROJECT NUMBER	
		5e. TASK NUMBER	
		5f. WORK UNIT NUMBER	
7. PERFORMING ORGANIZATION NAME(S) AND ADDRESS(ES) <b>Plasma Physics Division Naval Research Laboratory, Washington, D. C., 20375-5000</b>		8. PERFORMING ORGANIZATION REPORT NUMBER	
9. SPONSORING/MONITORING AGENCY NAME(S) AND ADDRESS(ES)		10. SPONSOR/MONITOR'S ACRONYM(S)	
		11. SPONSOR/MONITOR'S REPORT NUMBER(S)	
12. DISTRIBUTION/AVAILABILITY STATEMENT <b>Approved for public release, distribution unlimited</b>			
13. SUPPLEMENTARY NOTES <b>See also ADM002371. 2013 IEEE Pulsed Power Conference, Digest of Technical Papers 1976-2013, and Abstracts of the 2013 IEEE International Conference on Plasma Science. Held in San Francisco, CA on 16-21 June 2013. U.S. Government or Federal Purpose Rights License.</b>			
14. ABSTRACT			
15. SUBJECT TERMS			
16. SECURITY CLASSIFICATION OF:			17. LIMITATION OF ABSTRACT <b>SAR</b>
a REPORT <b>unclassified</b>	b ABSTRACT <b>unclassified</b>	c THIS PAGE <b>unclassified</b>	
			18. NUMBER OF PAGES <b>4</b>
			19a. NAME OF RESPONSIBLE PERSON

storing 22.4 kJ at 10.6 kV (Fig. 4). To maximize the energy transfer to the TF coils the circuit resistance and inductance must be minimized. It is also necessary to crowbar the 3 ms risetime pulse after current peak to prevent reversing the voltage on the capacitors. To obtain the precise TF field amplitude, the power supply charges the TF bank in 1 minute (10.6 kV, 10A max) to within 1% of the desired voltage and maintains that voltage level for two minutes after the charging process is completed.

The bank has several redundant equipment and personnel safety features. A thorough electrical fault analysis was conducted and protection was implemented to prevent cascading failures by several means. Each individual capacitor is protected by series resistors and fuses. The fuses are manufactured by McGraw-Edison and are utilized primarily in the power industry. The 200 m $\Omega$  resistors are constructed of corrugated ribbon wire wrapped around a ceramic core and coated with vitreous enamel. The bank is divided into 12 modules with 12 capacitors per module (Fig. 5). The modules are isolated from the output transmission line and each other by resistors constructed of stainless steel rod. During operation, the bank and coils are floating to avoid ground faults and single fault coupling of the TF and BF banks. Two parallel crowbar circuits are used to protect the bank from ringing in the event that one fails to fire.

Personnel safety is implemented by building interlocks and by a 5 tier bank dump and ground system. A pneumatic switching and time delay system is used to insure proper dump action even in the event of a power failure. The dumping sequence is as follows. A pneumatic relay switch dumps the entire bank into a series set of 10, 230 m $\Omega$ , 1800 watt edge wound power resistors. Five seconds later, a second redundant relay switch closes through a second resistor bank. Another five seconds later, the bank output is shorted. Five seconds later, the bank is connected to earth ground. Upon entry, the bank operator manually closes the shorting and grounding switch.

GE 8205 ignitron switches are used as the bank main output and crowbar switches. The charge conducted by the TF output switch is 750 Cb and by the crowbar is 1600 Cb. Therefore two parallel crowbar switches are required. The crowbar resistance was chosen to be 9 m $\Omega$  to produce an L/R decay of  $\sim$ 10 ms, therefore each parallel leg is 18 m $\Omega$ . Each 18 m $\Omega$  parallel crowbar resistor assembly is constructed of 176 resistors, each 200 m $\Omega$ , connected in 22 parallel legs of 8 resistors each.

The TF bank current flows out of the module high voltage buses into the bank main output stripline, which is converted over a short distance into a coaxial configuration to feed the output ignitron switch. At the switch the current divides into 32 parallel double braided RG 220 coaxial cables. By using 32 cables the resistance, inductance and forces are kept small and reliable energy transmission to the MBA ( $\sim$ 30 m) is obtained. At the MBA the cables are connected to a "snubber" where an RC cable matching network suppresses switching transients from reflecting in the cables. Finally, the current enters the TF coil to coil bus which connects the 12 TF coils in series. The coil-to-coil links comprise 4 parallel coaxial lines which use flexible 1.5 inch diameter insulated copper cables for the inner conductor and 2.5 inch diameter, 0.25 inch thick wall copper pipe for the outer conductor (Fig. 6). The return for the last coil is

shorted to complete the coaxial return for the series circuit.

The action integral,  $\int I^2 dt$ , for the high current, long decay MBA pulse is large, and high quality, low resistance joints are required. For example, with 200 kA peak currents and a decay time of 10 ms, the action is  $\sim$ 200 MJ/ $\Omega$ . In addition, spatial constraints demand that the contact area be kept small and high current densities result.

The MBA coil and bus systems use three different kinds of joints: Hugin spring joints, demountable mechanical screw clamps on copper braid, and copper to aluminum and aluminum to aluminum mechanical press joints. The resistance of these joints varies from 1 - 5  $\mu\Omega$  and, at 200 kA, the current densities are  $\sim$ 3 kA/cm<sup>2</sup>.

At the present 28% of the TF bank (40 capacitors, 890 kJ) is in operation for the beam injection and trapping experiment. The bank has been tested into a dummy load at 7 kV, 180 kA and is currently being operated into the TF coil load at voltages up to 7 kV.

#### Capture Field

A schematic of internal injection is shown in Fig. 1. During the first revolution around the major axis, i.e., during the first 20 nsec, the beam must drift poloidally a distance greater than the diameter of the injector anode to miss the diode. Such a drift occurs as a result of the forces on the beam centroid crossed with the toroidal field. However, the beam will return to strike the cathode after the first poloidal oscillation period ( $\sim$ 300 ns) unless  $r$  is moved radially inward. Since  $r$  is sensitive to the BF amplitude, a small change in the BF during the first poloidal oscillation can trap the beam. A set of fast coils located within the vacuum chamber produces the necessary capture field (CF) of a few Gauss. The CF coils are energized by a lumped parameter pulse forming line. The waveform decay time is  $\sim$ 400 ns. The beam is injected at the peak of the CF field and capture is completed during the decreasing portion of the pulse. By using a pulse forming line, the need for diodes or a crowbar circuit to prevent reversal of the CF is avoided.

The CF coil set consists of 9 turns mounted inside the vacuum chamber. The CF coil circuit is shown in Fig. 7. The pulse timing sequence for beam trapping in the internal injection experiment is shown in Fig. 8. The CF system is presently being tested.

#### Precision Injection Accelerator

The orbit matching conditions require a precise injection beam energy, therefore the pulse applied to the beam producing diode must have a low ripple ( $\Delta V/V < 1\%$ ) flat-top and excellent reproducibility (variation 1.5%). To minimize the perturbation of the head of the beam after one revolution by the falling electric field applied to the diode during the tail of the pulse, the voltage waveform must drop as fast as possible after the pulse flat-top. Also a fast pulse rise and fall time are required in order to minimize the damage to the vacuum chamber wall by unmatched electrons.

The precision accelerator (PAC) design consists of a Marx generator, a pulse forming line, an output switch, a ballast resistor, a tail-biter switch, and a vacuum transmission line [8].

The Marx generator is an oil insulated, 25 stage,  $\pm 50$  kV charge Marx with an erected capacitance of 6 nf. The Marx rises to a 2.5 MV peak in  $\sim 550$  nsec. Copper sulfate resistors are used throughout the Marx. An oil diverter switch prevents damage in the event that large amounts of energy are reflected back to the Marx.

The coaxial pulse forming line (PFL) design was based on the following factors in order to obtain a flat-topped low ripple pulse into a matched load: (1) the Marx continues to increase the voltage at one end of the line while the other end is already discharging, thus a geometrically tapered line is used as compensation, (2) the ratio of line diameter to line length is minimized, with electrical breakdown as the limiting factor, and (3) the line ends have precise field shaping and impedance control which is made easier by a PFL dielectric constant that is much greater than that of common insulating materials.

The first design consideration leads to a tapered line with  $12 \Omega$  at the Marx end and  $10.7 \Omega$  at the switch end. Additional adjustment of the pulse shape is obtained by mounting the inner conductor on a cam action eccentric which moves the Marx end of the line off center and reduces the local impedance to  $\sim 11.4 \Omega$ .

The second and third features are met, in part, by choosing ethylene glycol as the dielectric. Glycol has a dielectric constant of 40. Effective field shaping in the output switch is also employed.

The output switch is a self-breaking, SF<sub>6</sub> insulated switch. The switch body is constructed of a single piece epoxy casting which has a metal screen field shaper imbedded in the PFL side of the housing. The epoxy housing is machined such that the epoxy-glycol and epoxy-SF<sub>6</sub> interfaces in conjunction with the cast in field shaper provide good electric field grading while maintaining an almost perfect impedance characteristic in the glycol line. Variation of the PFL switchout time is achieved by precise gas density control.

A low impedance ( $\sim 12 \Omega$ ) constant temperature, CuSO<sub>4</sub> ballast resistor is used in parallel with the  $120 \Omega$  diode in order to obtain diode voltage regulation by matching the load ( $R_B$  in parallel with  $R_D$ ) to the PFL impedance. Thus, the voltage is held constant regardless of large variations in the diode impedance. The voltage across the matched PFL load (the diode voltage) is one half of the PFL voltage, i.e., 1.25 MV. A self-breaking "tail-biter" switch is used to decrease the output pulse fall time by diverting the late time PFL and Marx energy. The flat-top pulse duration can be shortened with this switch. The final section of the PAC is a  $120 \Omega$  vacuum transmission line terminated in a matched  $120 \Omega$  diode.

### Conclusions

The MBA pulsed power systems have been operating together successfully for over 450 shots at a rate of approximately 8 shots per hour. No major problems have occurred.

### Acknowledgements

The authors would like to extend thanks to Mr. Tom Johnson for his long and dedicated hours that helped make this project possible.

\* This work is supported by ONR and SDIO.

### References

- [1] J. Golden, J. Pasour, D. E. Pershing, K. Smith, F. Mako, S. Slinker, F. Mora, N. Orick, R. Altes, A. Fliflet, P. Champney and C.A. Kapetanakos, IEEE Trans Nuc. Sci. NS30 2114 (1983).
- [2] C. A. Kapetanakos, P. Sprangle, D. P. Chernin, S. J. Marsh, and I. Haber, Phys. Fl. 26 1634 (1983).
- [3] C. A. Kapetanakos, S. J. Marsh, and P. Sprangle, Phys. Rev. Lett. 49 741 (1982).
- [4] F. Mako, J. Golden, L. Floyd, K. McDonald, T. Smith and C.A. Kapetanakos, IEEE Trans. Nuc. Sci. to be published (1985).
- [5] C. A. Kapetanakos and S. J. Marsh, Memo Report 5387, NRL, Wash. DC (1984).
- [6] F. Mako, K. Smith, J. A. Pasour, D. E. Pershing, K. McDonald, R. Altes, J. Golden, and C. A. Kapetanakos, Proceedings of the 10 th Fusion Engineering Symposium, 5-9 Dec, 1983, Philadelphia, PA, IEEE Conf. Record, 705 (1984).
- [7] Hugin Industries, Inc., Los Altos, CA.
- [8] Beta Development Corp., Dublin, CA.

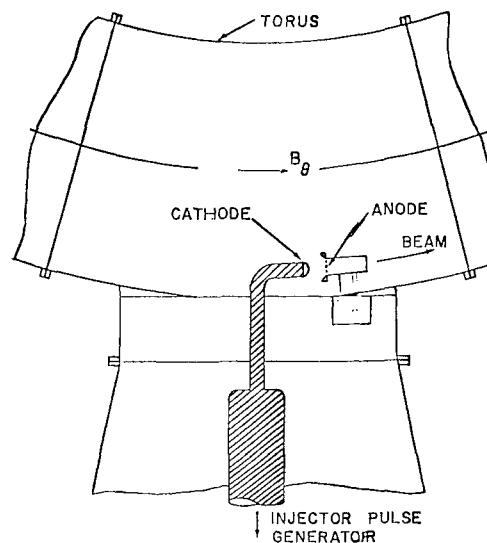

Fig. 1 Internal Injection

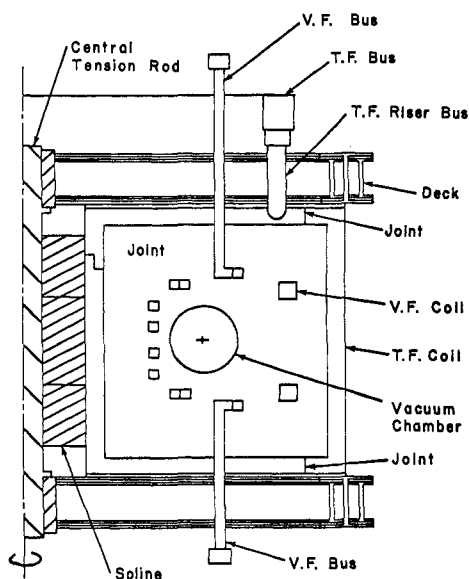

Fig. 2 Elevation of the NRL Modified Betatron showing coils, bus, and structural components.

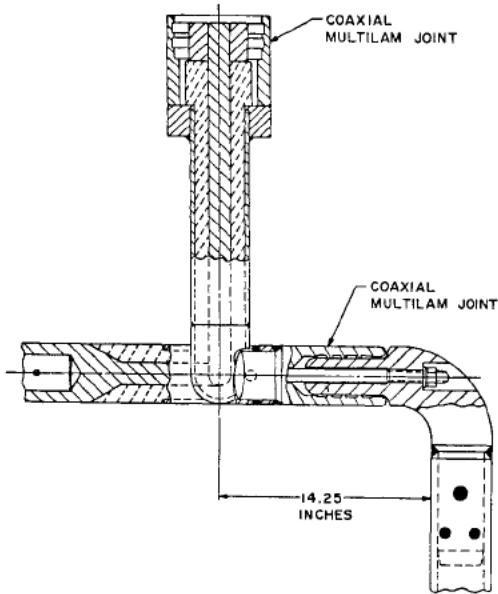

Fig. 3 TF Coil Linear to Coaxial Transition

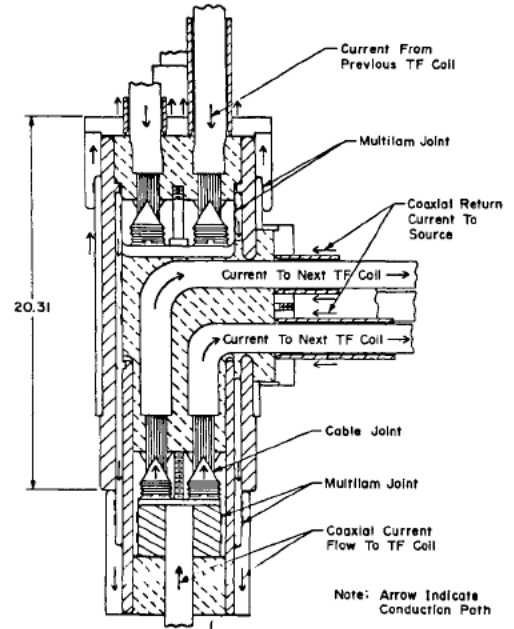

Fig. 6 TF Coil-to-Coil Bus Link

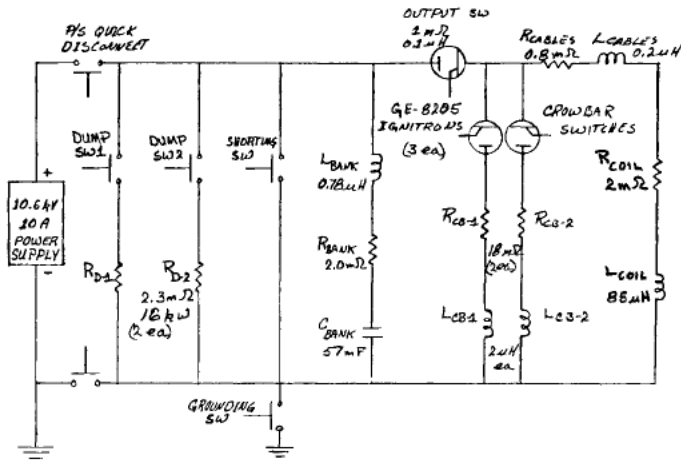

Fig. 4 TF System Schematic

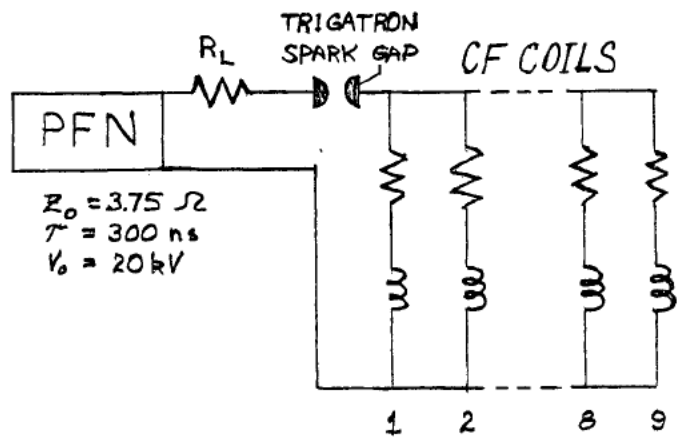

Fig. 7 Capture Field Schematic

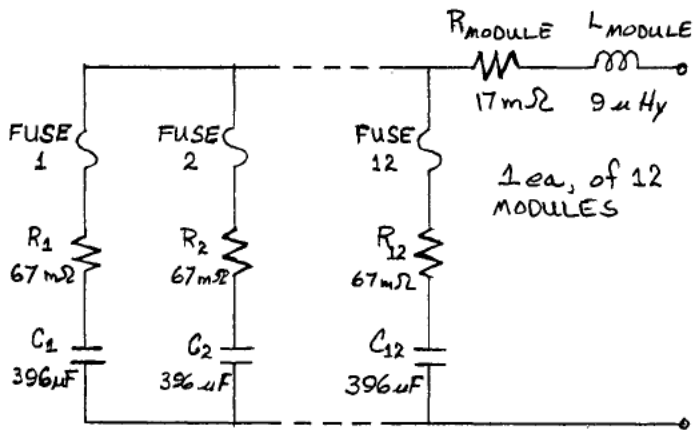

Fig. 5 TF Bank Module

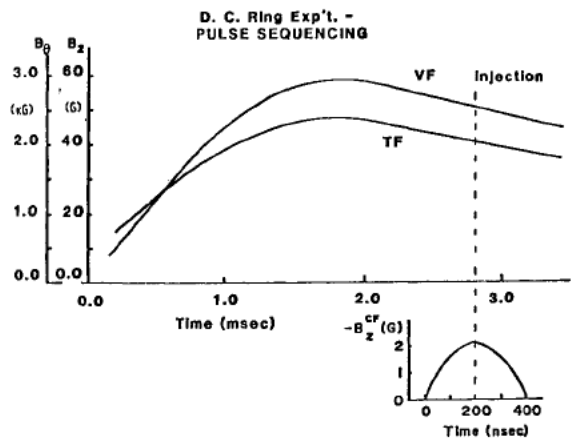

Fig. 8 Pulse Sequencing