

HIGH VOLTAGE CAPACITORS DESIGNED TO AVOID CATASTROPHIC FAILURE MODES

F. W. MacDougall G. L. McKee, J.B. Ennis, R.A. Cooper
Maxwell Energy Products, Inc. San Diego, CA.
R. M. Ness, - Cymer, Inc. San Diego CA.
W. A. Reass – Los Alamos National Laboratories

Abstract

A major concern in the operation of high voltage capacitors is the failure mode at end of life. While progress has been made in this area at lower voltages, little has changed for high current capacitors operating above 30 kV in steady state and pulsed power applications. Based on a new development at Maxwell Energy Products, Inc., it is now possible to build capacitors that can operate with a high degree of safety at high voltages. The capacitors reach the normal end of life, while avoiding the catastrophic failures, collateral damage, and unscheduled maintenance, associated with the normal failure mode of today's high voltage capacitors. This paper discusses the problem, capacitor failure modes, capacitor designs and describes a solution to the problem of catastrophic high voltage capacitor failures.

I. HISTORY

Over the years, the emphasis on pulsed power capacitor development has been on cost. The minimum requirements are normally expressed in terms of life expectancy, inductance, and in some cases volume. Some specifications go as far as to require that testing be done to demonstrate the quoted capability while other specifications have relied on extrapolated data from the manufacturer as an evaluation method.

Few specifications have reference to the failure mode associated with a capacitor. Probably the primary reason this occurs is that no one wants to dwell on the inevitable demise of the equipment. Until recently, it has been difficult to get a manufacturer to accept a contract where the capacitor failure mode is specified.

II. POWER FACTOR CAPACITORS

In the 1970s there was a major change in high voltage power factor correction (PFC) capacitors that resulted in an intensive investigation of the capacitor time current characteristics [1, 2]. The dielectric fluid in the capacitors was changed from non-flammable PCBs to flammable fluids like MIPB.

The time current characteristics for a high voltage PFC capacitors as well as typical expulsion and current-limiting fuses [3] is shown in Figure 1. There are three general areas of the curves shown. If the curves are extended out long enough in time, the devices will reach

“thermal stability” and the curves become constant current curves. At the fast end of the curve, the curves approach a constant I^2t . The I^2t value is often referred to as the “Action”. The constant Action section of the curve results from the inability of the devices to dissipate energy from the faulted area in the allotted time frame. Connecting the constant current and constant Action sections is the middle of the time current characteristic (TCC) curve.

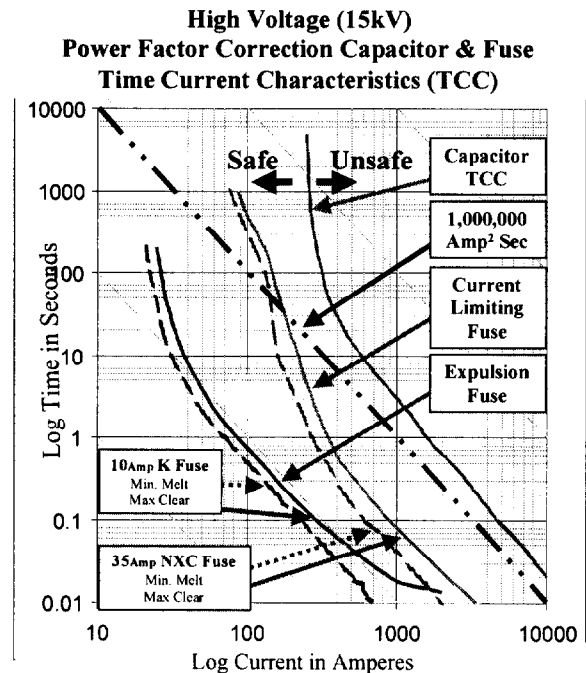

Figure 1. TCC curves.

Early on, it was realized that fuses could be used to minimize the collateral damage done when a capacitor fails. For fuses in general, there is a point where they will start to melt and a point at which they will always clear. If the fuse will clear before the case will rupture, the capacitor is properly protected. Note that the maximum clear curve for the expulsion fuse (10 amp K fuse) shown in Figure 1 approaches a minimum time to clear. This type of fuse will wait for a current zero to clear the circuit which can be as long as 0.8 cycles or 0.013 seconds at 60 Hz.

There is a second limit that must be considered when fusing PFC capacitors. If there is more than 9300 kVAR or 25 kJ in parallel, current limiting fuses must be used since the expulsion fuse will not interrupt the parallel

Report Documentation Page

Form Approved
OMB No. 0704-0188

Public reporting burden for the collection of information is estimated to average 1 hour per response, including the time for reviewing instructions, searching existing data sources, gathering and maintaining the data needed, and completing and reviewing the collection of information. Send comments regarding this burden estimate or any other aspect of this collection of information, including suggestions for reducing this burden, to Washington Headquarters Services, Directorate for Information Operations and Reports, 1215 Jefferson Davis Highway, Suite 1204, Arlington VA 22202-4302. Respondents should be aware that notwithstanding any other provision of law, no person shall be subject to a penalty for failing to comply with a collection of information if it does not display a currently valid OMB control number.

1. REPORT DATE JUN 1999		2. REPORT TYPE N/A		3. DATES COVERED -	
4. TITLE AND SUBTITLE High Voltage Capacitors Designed To Avoid Catastrophic Failure Modes				5a. CONTRACT NUMBER	
				5b. GRANT NUMBER	
				5c. PROGRAM ELEMENT NUMBER	
6. AUTHOR(S)				5d. PROJECT NUMBER	
				5e. TASK NUMBER	
				5f. WORK UNIT NUMBER	
7. PERFORMING ORGANIZATION NAME(S) AND ADDRESS(ES) Maxwell Energy Products, Inc. San Diego, CA.				8. PERFORMING ORGANIZATION REPORT NUMBER	
9. SPONSORING/MONITORING AGENCY NAME(S) AND ADDRESS(ES)				10. SPONSOR/MONITOR'S ACRONYM(S)	
				11. SPONSOR/MONITOR'S REPORT NUMBER(S)	
12. DISTRIBUTION/AVAILABILITY STATEMENT Approved for public release, distribution unlimited					
13. SUPPLEMENTARY NOTES See also ADM002371. 2013 IEEE Pulsed Power Conference, Digest of Technical Papers 1976-2013, and Abstracts of the 2013 IEEE International Conference on Plasma Science. Held in San Francisco, CA on 16-21 June 2013. U.S. Government or Federal Purpose Rights License.					
14. ABSTRACT A major concern in the operation of high voltage capacitors is the failure mode at end of life. While progress has been made in this area at lower voltages, little has changed for high current capacitors operating above 30 kV in steady state and pulsed power applications. Based on a new development at Maxwell Energy Products, Inc., it is now possible to build capacitors that can operate with a high degree of safety at high voltages. The capacitors reach the normal end of life, while avoiding the catastrophic failures, collateral damage, and unscheduled maintenance, associated with the normal failure mode of todays high voltage capacitors. This paper discusses the problem, capacitor failure modes, capacitor designs and describes a solution to the problem of catastrophic high voltage capacitor failures.					
15. SUBJECT TERMS					
16. SECURITY CLASSIFICATION OF:			17. LIMITATION OF ABSTRACT SAR	18. NUMBER OF PAGES 5	19a. NAME OF RESPONSIBLE PERSON
a. REPORT unclassified	b. ABSTRACT unclassified	c. THIS PAGE unclassified			

discharge of energy into the capacitor that has failed and the energy level will be high enough to rupture the capacitor case due to stored energy in the bank.

III. PULSE POWER CAPACITORS

Unlike PFC capacitors, pulse power capacitors come in a wide variety of designs for very specific applications. No group has been studied as extensively as PFC capacitors, with the possible exception of the capacitors developed for NIF, but the principles developed during the PFC capacitor study are applicable to energy storage capacitors.

Fuses are available for pulsed power capacitors [4]. The time frame of interest for single shot pulse power fuse is short and falls into the constant Action area. Typical values are shown in Figure 2.

Maxwell Value Range for Standard 22kV Capacitor Fuses			
Item	Small	Large	Units
Rated Current	25	59	Amps
Inductance	250	150	nH
20°C Res.	74	13	mOhm
250°C Res.	145	25	mOhm
Action (Min)	1.5k	54k	Amp ² Sec
Action to Clear	6.3k	222k	Amp ² Sec

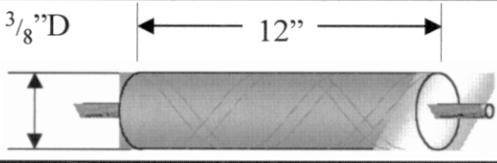

Figure 2. Pulse power current limiting fuses.

Considering the Action integral in terms of Amp² Sec as it applies to energy storage capacitors is a little difficult, but the units of measure can be changed. For the evaluation of the amount of energy that can be absorbed by a capacitor the values could be state as:

$$\text{Amp}^2 \text{ Seconds} = \text{Joules}/\Omega \quad (1)$$

where:

$$\begin{aligned} \text{Joules} &\equiv \text{Energy Stored} \\ \Omega &\equiv \text{The failure resistance} \end{aligned}$$

The energy stored in a capacitor or capacitor bank is relatively easy to calculate. Determining the fault resistance is not. The resistance of interest is not the fault circuit resistance but the resistance at the fault point inside the capacitor that will generate the arc plasma and from which no heat will escape. While this value is difficult to measure, it can be said that capacitors with low resistance faults can absorb more energy than those with high resistance faults before the case ruptures, because the energy is dissipated away from the fault point.

Figure 3 shows a typical foil capacitor that has failed and has been dissected. A typical failure spreads vertically because that is the way the layers are mechanically set up and it penetrates horizontally through layer after layer of dielectric and electrode picking up energy as it penetrates each layer. As the layers of electrodes are penetrated, they are also mechanically and electrically interconnected. The resistance between the foils after the fault is the resistance of in Formula 1. The shorting of foils during the failure process is an inconsistent process with a wide variation in resistance that changes in response to current surges. However, experienced capacitor designers can design capacitors that will fair better than others in the dynamic environment of an internal fault.

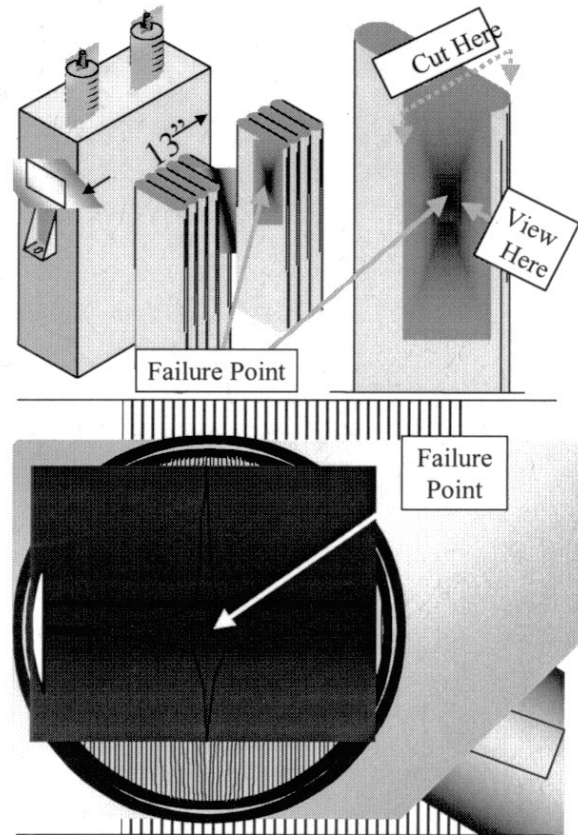

Figure 3. Foil electrode capacitor dissection.

Foil electrode pulsed power capacitors are available today operating between 10 kV and 100 kV, with peak currents in the 1/2 M Amp range, and storing 60 kJ that do not tend to rupture when they fail as terminal to terminal shorts. This can be attributed to the internal design and construction of the capacitors.

Self-clearing capacitors utilize metallized electrodes that are only a few hundred angstroms thick. Should the dielectric fail, the capacitor is designed so that the fault current will clear away the electrode before any significant current can flow through the fault. Metallized electrode capacitors are not self-clearing under all conditions of operation. One way to defeat the self-

clearing mechanism is to increasing the voltage across the capacitor until it shorts.

If the self-clearing mechanism is defeated, the fault area looks similar to that shown in Figure 4. The lower part of Figure 4 shows the layers inside a typical metallized electrode capacitor. The black area going from the endspray at one end of the winding to the other is typical of what happens when the self-clearing mechanism is defeated. Since the fault path is several inches long, the relative resistance of the fault is high. The amount of energy that the capacitor can absorb with this type of fault without rupturing is very limited. The larger metallized electrode energy storage capacitors store well over 25 kJ and tend to rupture the case if a fault like that shown in Figure 4 occurs inside the capacitor.

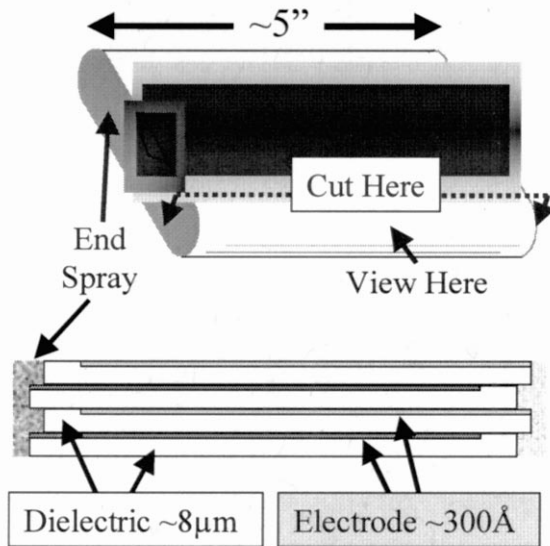

Figure 4. Metallized electrode capacitor dissection.

Again, experienced capacitor designers have developed commercially available capacitors for pulsed power application that do not suffer from this failure mode. The capacitors are available at voltages of up to 40kV.

IV. HIGH VOLTAGE CAPACITORS FOR CONTINUOUS PULSED POWER OPERATION

For some applications, capacitor banks are designed with high voltage capacitors that must operate under continuous pulse power duty. Often, the inductance and resistance of the fuse as listed in Figure 2 will be more than can be tolerated by the machine design parameters. Whether or not fuses are used, the failure of a capacitor comes as a surprise and is often accompanied by an unscheduled equipment shutdown.

The capacitors used are typically designed for long life and, as a result operate at fairly low stresses compared to their high energy density single pulse counterparts. As shown in Figure 5, the failure normally progresses from a

single shorted internal series section (5b) to the point where about half the windings are shorted (5c) and at that time, the remaining windings tend to short simultaneously. Generally, because of the high peak currents associated with pulse power applications, the failed capacitor will not reach thermal equilibrium and the failure will progress. The time it takes to for the capacitor to progress from the initial fault (5b) to the point where the capacitor is a dead short (5d) is significant. During this time, there may be arcing at the failure point and gas generated inside the capacitor. If this situation is allowed to continue for any length of time, it is likely that the capacitor case will rupture resulting in the unscheduled shut down of the equipment.

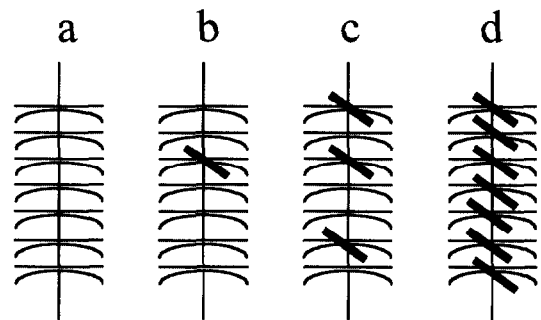

- a Normal Capacitor
- b First Section Failure
- c < Half the sections failed (Not a usual condition for high energy density pulsed power capacitors)
- d Capacitor shorted terminal to terminal.

Figure 5. Typical failure progression in a high voltage foil electrode pulsed power capacitor.

Figure 6 is a schematic of high voltage capacitor with an internal unbalance detection scheme. As long as the

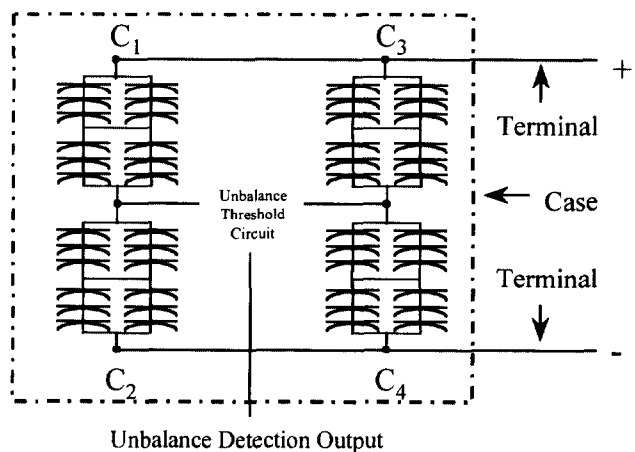

Figure 6. High voltage capacitor with an internal unbalance detection circuit.

impedance of $C1/C2 = C3/C4$, there is no voltage across the unbalance threshold circuit. If one of the internal series sections shorts, the balanced circuit will become unbalanced and there will be a signal. A typical threshold detector is shown in Figure 7. Here the unbalance signal is rectified and accumulated on a capacitor until the voltage is high enough to cause the neon lamp to flash. The output of this circuit is a series of light pulses with the flash rate increasing as the failure in the capacitor progresses.

If one of the groups of internal capacitor sections in Figure 6 starts to go through the failure sequence of Figure 5, the flash rate can be used to identify the initial internal capacitor section failure. It can also be used to determine if the internal failure has progressed beyond the initial section failure.

For many applications, capacitors can be designed so that the capacitors will remain stable for some period of time after the initial fault has taken place. That being the case, an ALARM function associated with the initial internal capacitor section failure, can be used to indicate that the capacitor needs to be change out at the next scheduled maintenance. Also, if the failure progresses from the initial internal section failure to the point where a major fault is of concern, a second signal level can be used to shut down or STOP the equipment before a catastrophic failure takes place.

In order to have an ALARM and STOP function, the capacitor must be designed to carry the available current

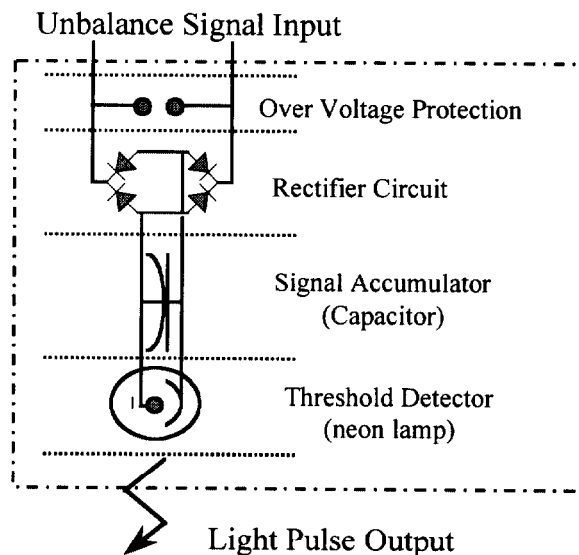

Figure 7. Typical threshold detector (Relaxation Oscillator).

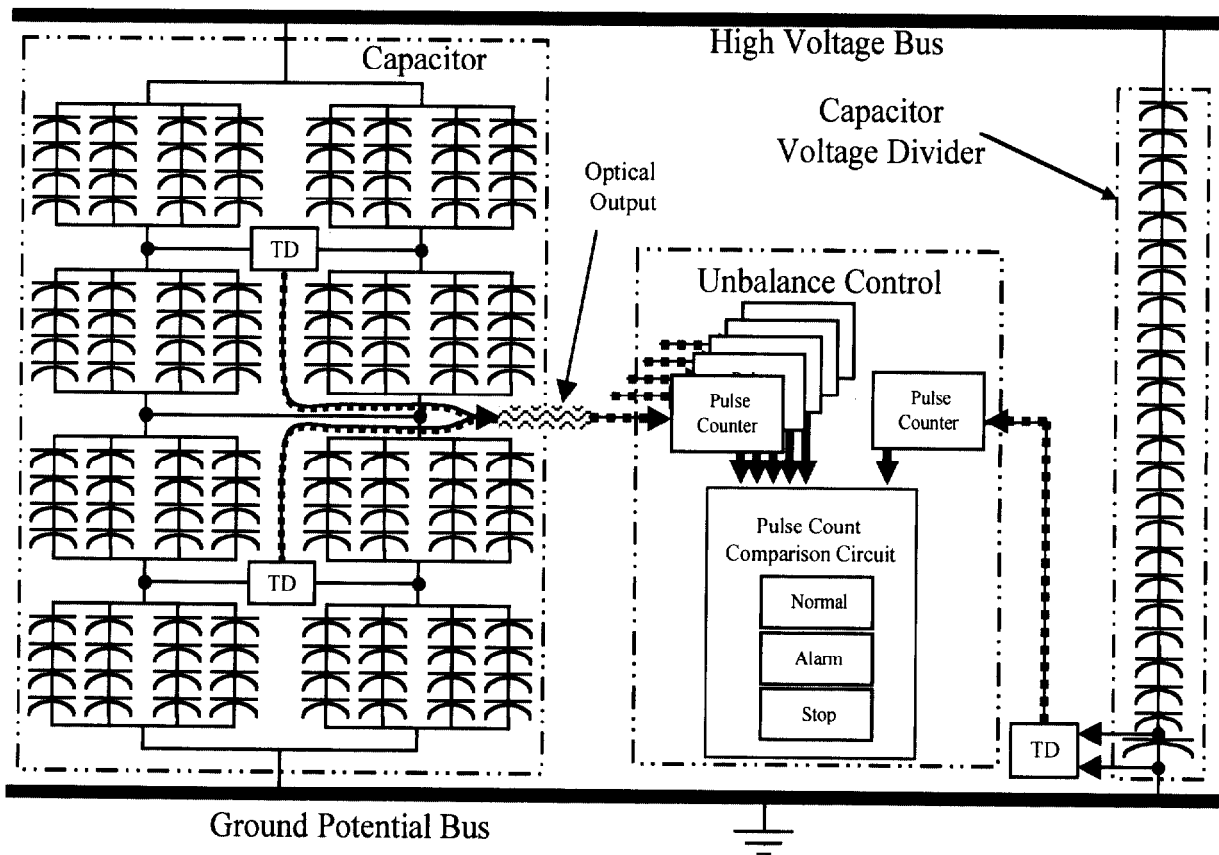

Figure 8. Schematic diagram of an unbalance detection circuit.

after the initial internal failure has occurred. Also, the circuit must be sensitive to the fault level. The schematic of Figure 8 shows a typical schematic for a high voltage capacitor bank using an unbalance detection scheme to monitor the condition of the capacitors. The capacitors in the bank each have two internal threshold detectors (TD) feeding into a single optical output. The light output is fed into a pulse counter that keeps track of the condition of the capacitors.

The unbalance signal associated with the failure of an internal capacitor section can be calculated in terms of the bus voltage. In pulse power applications, the bus voltage can vary significantly, operating at different levels, charging and discharging the capacitor. In the circuit of Figure 8, a separate capacitive voltage divider is used to determine what voltage signal is on the bus.

A separate circuit compares the output from the bus to the output from the capacitors to determine the relative unbalance each of the capacitors in the bank. The output of the comparison circuit is a set of contacts that indicate that the situation is NORMAL, or an ALARM for the initial failure of an internal capacitor section, or a STOP signal that will be generated if the internal failure progresses to the point of concern.

Figure 9 is an example of a high voltage capacitor might look like with an internal unbalance detection scheme and fiber optic output. At the time of this writing, the unbalance detection scheme with its controls is still under development. Patent applications have been filed. The schemes that are being evaluated at this time are application specific. It is believed that this effort will result in the development of equipment that can be used in general applications

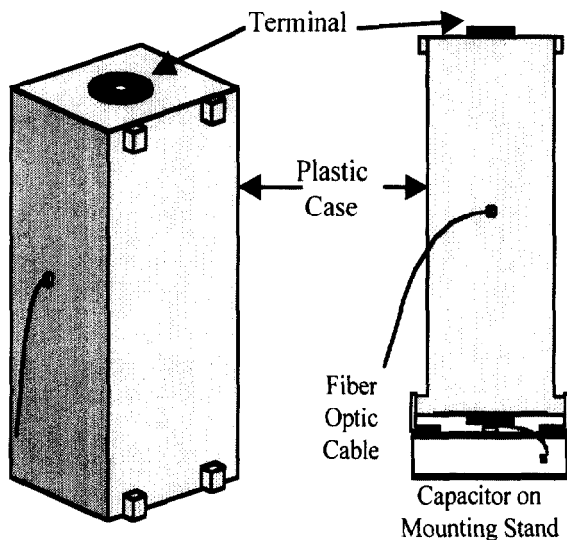

Figure 9. High voltage plastic case capacitor with an internal unbalance detection scheme and a fiber optic output.

V. CONCLUSIONS

An understanding the failure modes of pulse discharge capacitors can allow users to avoid the problems associated with capacitor failures. There is equipment available to day that will allow the user to avoid most catastrophic failures in a wide variety of applications. These include the use of fuses, as well as properly applied foil electrode and metallized electrode capacitors. One area where there is a lack of good solutions is the high voltage repetition rate capacitor banks discharging in microseconds. Here, the unbalance detection scheme described above is designed to fill the void and allow continuous operation with minimal disruptions due to failing capacitors.

VI. REFERENCES

- [1] Lawrence M. Burrage, Shunt Capacitor Rupture Prevention – Large Bank Applications, IEEE A76 366-5
- [2] Lawrence M. Burrage, Capacitor Tank-Rupture Prevention – 1st Considerations, IEEE Transactions on Power Apparatus and Systems, Vol. PAS-97, no 2, Mar/Apr 1978, IEEE No. F 77 567-1
- [3] Cooper Power Systems Reference Data: R230-91-1, R240-91-2, R240-91-38.
- [4] Maxwell Energy Products – High Energy Capacitor Protection Fuse Selection Guide.