

DESIGN CONCEPTS FOR PBFA-II'S APPLIED-B ION DIODE*

D. C. Rovang
Sandia National Laboratories
Albuquerque, New Mexico 87185

Abstract

The lithium ion diode to be used at the center of Particle Beam Fusion Accelerator-II (PBFA-II) at Sandia National Laboratories is an applied-B ion diode. The center section of the PBFA-II accelerator is where the electrical requirements of the accelerator, the design requirements of the diode, and the operational requirements must all be satisfied simultaneously for a successful experiment. From an operational standpoint, the ion diode is the experimental hub of the accelerator and needs to be easily and quickly installed and removed. Because of the physical size and geometry of the PBFA-II center section, achieving the operational requirements has presented an interesting design challenge. A discussion of the various design requirements and the proposed concepts for satisfying them is presented.

Introduction

A particle beam fusion accelerator consists primarily of two major elements 1) the electrical driver and 2) the diode region. The electrical driver supplies a high voltage, high power pulse to the diode. The diode uses the energy of the pulse to create, focus, and accelerate ions toward a target. Electrically and mechanically, the driver of PBFA-II can be divided into three sections: an energy storage or oil section, a pulse forming or water section and a magnetically insulated transmission line (MITL) section or vacuum section. Figure 1 shows how each of these fits into the overall geometry of PBFA II. The diode for PBFA-II is located at the center of the accelerator and is attached mechanically and electrically to the MITLs in the vacuum section (Figure 2). It is in the ion diode region (Figure 3) where the electrical requirements of the driver, the design requirements of the ion diode, and the operational requirements must all be satisfied simultaneously for a successful experiment. The hardware for the PBFA-II ion diode is now in the final stages of design. An overview of the design requirements and a description of the proposed design is the subject of this paper.

* This work supported by U.S. Dept. of Energy under contract DE-AC04-76DP00789.

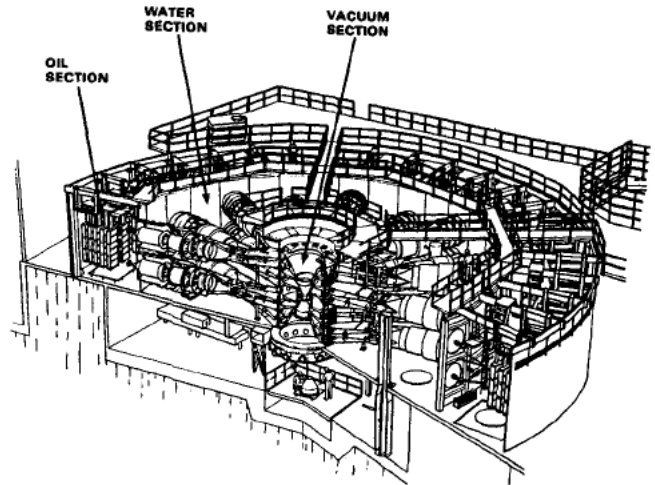

Figure 1. Artist's illustration of PBFA-II.

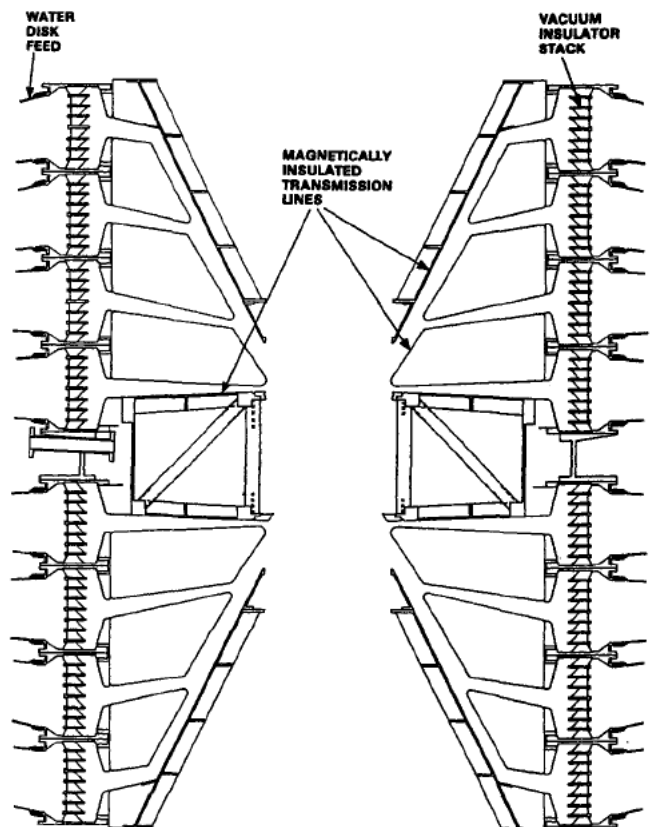

Figure 2. Cross section of PBFA-II vacuum section without diode hardware.

Report Documentation Page

Form Approved
OMB No. 0704-0188

Public reporting burden for the collection of information is estimated to average 1 hour per response, including the time for reviewing instructions, searching existing data sources, gathering and maintaining the data needed, and completing and reviewing the collection of information. Send comments regarding this burden estimate or any other aspect of this collection of information, including suggestions for reducing this burden, to Washington Headquarters Services, Directorate for Information Operations and Reports, 1215 Jefferson Davis Highway, Suite 1204, Arlington VA 22202-4302. Respondents should be aware that notwithstanding any other provision of law, no person shall be subject to a penalty for failing to comply with a collection of information if it does not display a currently valid OMB control number.

1. REPORT DATE JUN 1985	2. REPORT TYPE N/A	3. DATES COVERED -	
4. TITLE AND SUBTITLE Design Concepts For PBFA-II'S Applied-B Ion Diode		5a. CONTRACT NUMBER	
		5b. GRANT NUMBER	
		5c. PROGRAM ELEMENT NUMBER	
6. AUTHOR(S)		5d. PROJECT NUMBER	
		5e. TASK NUMBER	
		5f. WORK UNIT NUMBER	
7. PERFORMING ORGANIZATION NAME(S) AND ADDRESS(ES) Sandia National Laboratories Albuquerque, New Mexico 87185		8. PERFORMING ORGANIZATION REPORT NUMBER	
9. SPONSORING/MONITORING AGENCY NAME(S) AND ADDRESS(ES)		10. SPONSOR/MONITOR'S ACRONYM(S)	
		11. SPONSOR/MONITOR'S REPORT NUMBER(S)	
12. DISTRIBUTION/AVAILABILITY STATEMENT Approved for public release, distribution unlimited			
13. SUPPLEMENTARY NOTES See also ADM002371. 2013 IEEE Pulsed Power Conference, Digest of Technical Papers 1976-2013, and Abstracts of the 2013 IEEE International Conference on Plasma Science. Held in San Francisco, CA on 16-21 June 2013. U.S. Government or Federal Purpose Rights License.			
14. ABSTRACT The lithium ion diode to be used at the center of Particle Beam Fusion Accelerator-II (PBFA-II) at Sandia National Laboratories is an applied-B ion diode. The center section of the PBFA-II accelerator is where the electrical requirements of the accelerator, the design requirements of the diode, and the operational requirements must all be satisfied simultaneously for a successful experiment. From an operational standpoint, the ion diode is the experimental hub of the accelerator and needs to be easily and quickly installed and removed. Because of the physical size and geometry of the PBFA-II center section, achieving the operational requirements has presented an interesting design challenge. A discussion of the various design requirements and the proposed concepts for satisfying them is presented.			
15. SUBJECT TERMS			
16. SECURITY CLASSIFICATION OF:			17. LIMITATION OF ABSTRACT
a REPORT unclassified	b ABSTRACT unclassified	c THIS PAGE unclassified	SAR
			18. NUMBER OF PAGES 4
			19a. NAME OF RESPONSIBLE PERSON

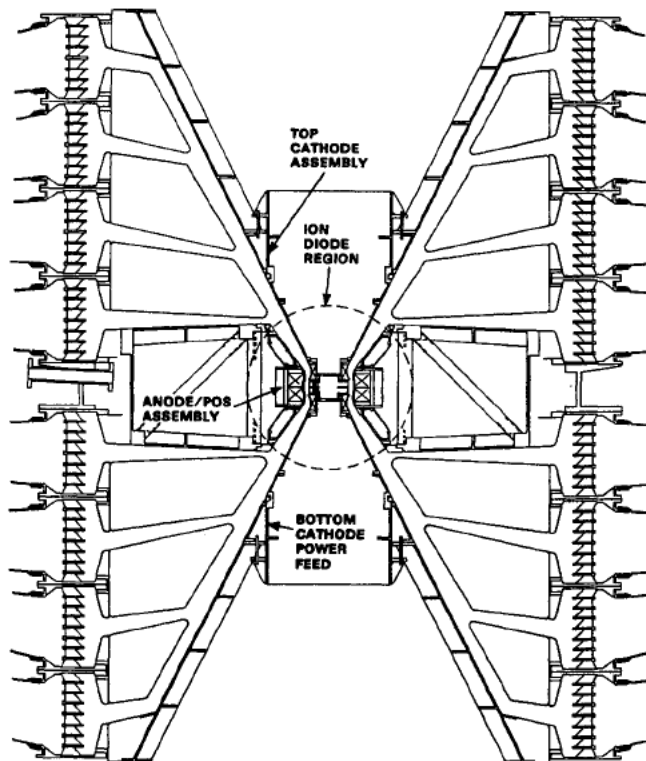

Figure 3. Cross section of PBFA-II vacuum section with diode hardware installed.

Ion Diode Theory

Figure 4 is a cross-sectional view of the ion diode. The PBFA-II applied-B ion diode is made up of three major elements: 1) the anode, 2) the cathode and 3) the gas cell. As the pulse from the electrical driver arrives at the ion diode, a plasma is formed at the concave, cylindrical surface of the anode. Simultaneously, the pulse raises the voltage of the anode to tens of megavolts above the cathode potential. This potential difference accelerates positive ions from the anode plasma or ion source across the anode-cathode gap (A-K gap) and focuses them toward the center of the gas cell. The gas cell, which is enclosed by a thin Mylar membrane, contains a low density gas that becomes ionized as the ion beam travels through it. This ionized gas or plasma keeps the ion beam space charge and current neutralized allowing the ion beam to remain focused.

The focusing of the ions occurs primarily in the A-K gap between the ion source and the Mylar membrane. Electrons emitted at the cathode are prevented from crossing the A-K gap by the magnetic field generated by the pulsed field coils. The electrons trapped along the magnetic field lines in the A-K gap help define equipotential surfaces which focus the ions in a fashion similar to the way an optical lens focuses light.

MITL Design Requirements

The magnetically insulated transmission lines, commonly referred to as vacuum convolutes, electrically connect the pulse forming section to the ion diode region. The convolutes are large aluminum weldments that weigh as much as 2000

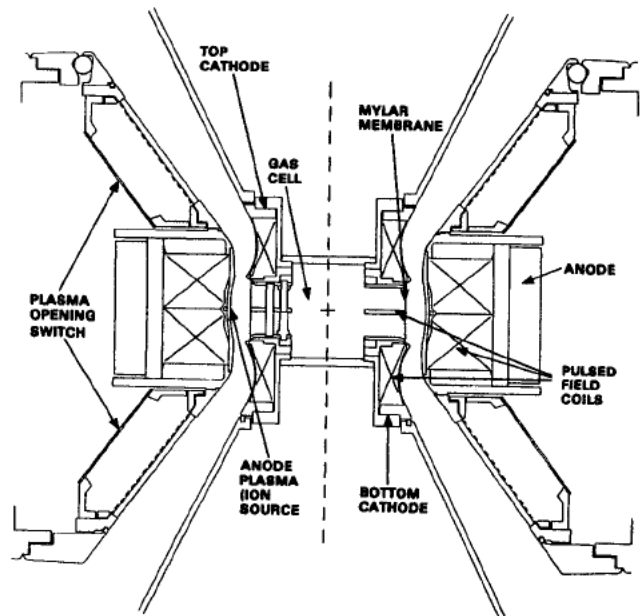

Figure 4. Ion diode region for PBFA-II.

pounds each. The convolutes are mechanically and electrically connected to rings that are an integral part of the vacuum insulator stack. The gaps formed by adjacent surfaces of the convolutes act as waveguides for the electrical power pulse being delivered to the diode. The shapes of the MITL surfaces were determined by power flow requirements. The power flow considerations that influenced these surfaces most were

- 1) voltage addition requirements
- 2) impedance matching requirements
- 3) shaping of the cathode surfaces to reduce electron losses.

Also included in the MITL design criteria was a requirement to provide space for the plasma opening switch (POS) system immediately next to the ion diode. Although the design of the MITLs did not influence the design of the ion diode directly, their design did influence to a large extent the location of the electrical and mechanical joints for installation and assembly of the ion diode.

Ion Diode Design Requirements

Several competing factors related to the physics of an ion diode determine its size. These factors include

- 1) current density limitations due to beam stability problems
- 2) power density considerations
- 3) criteria for matching the impedance of the electrical driver to the diode
- 4) ion source or anode plasma current density limitations
- 5) magnetic field strength considerations
- 6) transit time spreading of the beam
- 7) A-K gap closure
- 8) intrinsic beam divergence.

For practical purposes, the theoretical design size of the ion diode for PBFA-II was based primarily on previous successful ion diode designs. The overall physical size of the ion diode was determined mainly by the magnetic field/coil design considerations.

One of the design challenges presented by the ion diode design requirements was the alignment of the anode relative to the cathodes. Alignment is crucial because of power flow, ion focusing, and target performance considerations. The anode and cathode must be aligned to each other within several thousandths of an inch after installation, which is complicated by large stack movements during vacuum pumpdown.

Operational Requirements

The first operational requirement placed upon the ion diode hardware was the capability of installing and removing the ion diode with the vacuum convolute hardware in place. Early in the operational life of PBFA-II most of the MITL hardware will be removed between diode experiments, but eventually it is hoped that this will not be necessary. The main reason this is desired is to minimize turnaround time between diode experiments and thereby achieve a higher shot rate and a faster learning rate.

Because of the physical size and geometry of the PBFA-II, installing and removing the ion diode hardware with all the MITL hardware in place presents an access problem. It was determined early in the design of the PBFA-II center section that the only way to reach the center of diode region from the top was by inverted human access. Although this might have been allowed on a limited basis, operational procedures requiring inverted human access did not seem practical from a safety standpoint nor conducive to minimizing turnaround time between experiments. A decision was made to avoid inverted human access if at all possible.

Presently, on PBFA-I a good deal of time is spent assembling and aligning the ion diode hardware in situ. There are several reasons why this is not desirable or practical on PBFA-II. The limited access presents a major problem. Another reason is that the PBFA-II center section is a confined place with relatively poor working conditions. Also, the ion diode hardware for PBFA-II has become so complex and massive that assembly in situ is unrealistic. Therefore, it was decided to minimize the number of assemblies required to complete the installation of the ion diode hardware. It was also proposed that the alignment of the cathode and anode be done outside the accelerator and this alignment be transferred into the machine, thereby eliminating alignment in situ.

Proposed Design

Three major assemblies are required to complete the installation of the ion diode for PBFA-II. These are

- 1) the anode/POS assembly
- 2) the top cathode assembly
- 3) the bottom cathode power feed.

The anode/POS assembly is first lowered into position from the top (Figure 5). The outer diameter of the anode/POS assembly is limited by the requirement to clear the inner radius of the vacuum convolute structure that is next to the center vacuum convolute. This is what eventually limited the desired size or area of the plasma opening switch. There would have been more room to accommodate a larger plasma opening switch, but this would have required relaxation of the MITL design criteria that required the cathode surfaces to slope into the flow pattern of electron flow to reduce electron losses.

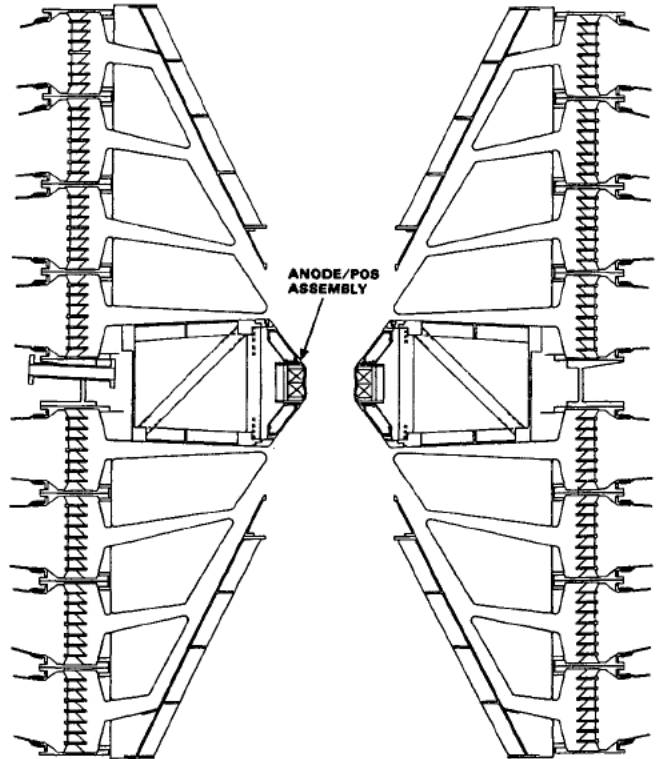

Figure 5. Cross section of PBFA-II vacuum section with anode/POS assembly installed.

Because of the auxiliary electrical and mechanical connections that must be made to the anode/POS assembly upon installation, the assembly must first be lowered only part way into position. At that time a person working from the bottom will make the necessary auxiliary connections. The anode/POS assembly is then lowered onto its bottom mounting or alignment surface and locked into place. Because access was limited to the bottom of the anode/POS assembly, it was necessary to incorporate a self-actuating system that provides electrical current contact and also provides mechanical support at the top of the anode/POS assembly. The proposed solution is an inflatable current seal originally developed by Pulse Sciences Incorporated for use on Proto-II at Sandia National Laboratories. This current seal will be remotely actuated once the anode/POS assembly is in place.

This type of current seal is also proposed to be used where the top cathode assembly and bottom cathode power feed mate with the large MITL cathode cones. Because the anode/POS assembly must fit past this joint, the position of the joint was determined by clearance required for the outer diameter of the anode/POS assembly. Although the bottom power feed did not have this clearance requirement, it was decided that making the top and bottom as symmetrical as possible was desirable for minimizing manufacturing costs and the number of spare parts.

After the anode/POS assembly is in place, the top cathode assembly is lowered into position (Figure 6). The top cathode assembly includes both cathode halves and the gas cell. There are several reasons why it is desirable for the cathodes and gas cell to be installed as a pre-assembled unit. Magnet current connections and feedthroughs need to be made in the gas cell that would be nearly impossible to complete upon installation. Also the cathodes, which are made out of stainless steel, provide protection for the relatively fragile gas cell. Most important, however, is that as an assembled unit the cathodes and gas cell could be aligned to the anode in a single alignment operation.

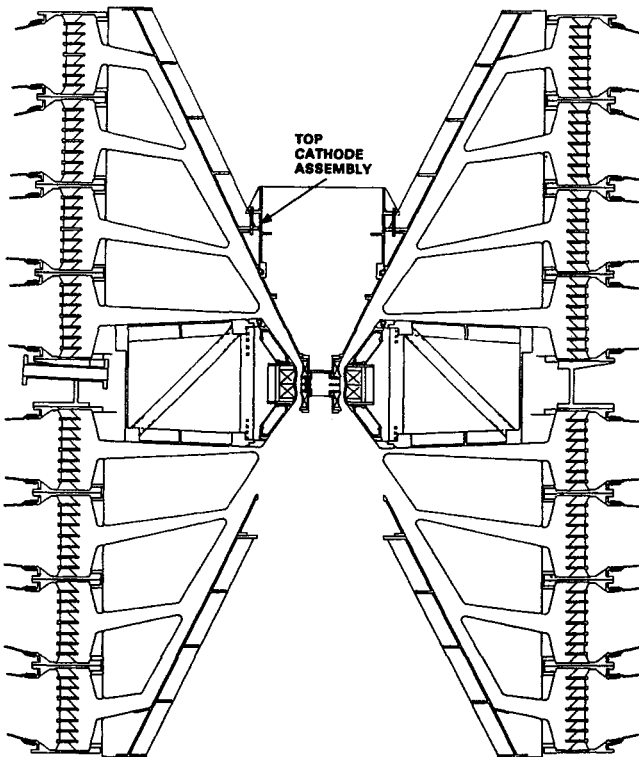

Figure 6. Cross section of PBFA-II with top cathode assembly installed.

Outside the accelerator a reference fixture will be provided that has two sets of mounting surfaces, one for the anode/POS assembly and one for the top cathode assembly. Once aligned, the diode hardware will be removed from the reference fixtures and placed in a staging area. An alignment tool will then be placed in the reference fixture. The alignment tool will be used to transfer the relative location of the mounting surfaces on the reference fixture to similar mounting surfaces inside the machine. These mounting surfaces will then be adjusted to match those outside the machine in the reference fixture. Once this is accomplished the alignment tool will be removed and the ion diode hardware will be lowered into place and locked into position.

This alignment scheme might sound straightforward at first but there is a complicating factor: the entire vacuum stack compresses during vacuum pumpdown. Although the alignment procedure will include compensation for this movement, proposed methods assume that vacuum stack movement is repeatable from pumpdown to pumpdown. If stack movement is not repeatable to within the alignment tolerance desired by the diode-physics experimenters, then an automated alignment scheme will have to be developed.

The bottom cathode power feed will be installed last from the bottom. It will be guided into position using guide pins attached to the top cathode assembly. This will ensure the necessary concentric alignment. A crushable current seal made of metal braid will be used to make the electrical connection between the bottom cathode power feed and the top cathode assembly. At installation it will be compressed slightly and then during vacuum pumpdown will be compressed further to ensure that good electrical contact is achieved.

Conclusion

The hardware for the PBFA-II ion diode is now in the final stages of design. The proposed design is an attempt to satisfy simultaneously the design requirements of the magnetically insulated transmission lines, the design requirements of the ion diode, and the operational requirements of the accelerator.

Because of the experimental nature of the PBFA-II ion diode region, modifications of the present design are expected. In anticipation of these modifications, adaptable features have been designed into the hardware at the locations where the ion diode hardware mates with the vacuum convolute hardware. These features should facilitate the anticipated modifications of ion diode and plasma opening switch hardware.