

# THE LIGHT ION PULSED POWER INDUCTION ACCELERATOR FOR ETF\*

M. G. Mazarakis, R. E. Olson, C. L. Olson D. L. Smith, and L. F. Bennett  
Sandia National Laboratories  
P. O. Box 5800  
Albuquerque, NM 87185-1193

## Abstract

The light ion Engineering Test Facility (ETF) driver concept, based on Hermes III<sup>1</sup> and RHEPP<sup>2</sup> technologies, is a scaled-down version of the LMF<sup>3</sup> design incorporating repetition rate capabilities of up to 10 Hz. The preconceptual design presented here provides 250-TW peak power to the ETF target during 8 ns, equal to 2-MJ total ion beam energy. Linear inductive voltage addition driving a self-magnetically insulated transmission line (MITL) is utilized to generate the 36-MV peak voltage needed for lithium ion beams. The ~ 3-MA ion current is achieved by utilizing many accelerating modules in parallel. Since the current per module is relatively modest (~ 300 kA), two-stage or one-stage extraction diodes can be utilized for the generation of singly charged lithium ions. The accelerating modules are arranged symmetrically around the fusion chamber in order to provide uniform irradiation onto the ETF target. In addition, the modules are fired in a programmed sequence in order to generate the optimum power pulse shape onto the target. This design utilizes RHEPP accelerator modules as the principal power source.

## Introduction

The Engineering Test Facility (ETF) has as its goal: to study moderate gain Inertial Confinement Fusion (ICF) targets and to provide the technical development necessary to demonstrate scientific and engineering feasibility for fusion energy production with a reprinted driver. In order for ETF to be cost effective, the accelerator system must be able to drive several target chambers which will test various Inertial Fusion Energy (IFE) reactor technologies. We envision an elevator system positioning and removing multiple target chambers from the center area of the ion beam delivering system.

The light ion ETF pre-conceptual design is based upon the ion beam input requirements of a ~ 10-MJ yield ICF target. The driver design is modular and consists of 24 modules of two different types: A and B (Fig. 1). These modules are fired in a two-step sequence to provide the desired power pulse shape on the target (Fig. 2). The first pulse to arrive at the target, generated by the 12 A modules, is a 4-MeV helium ion beam irradiating the target with 20 TW for 30 ns. The main pulse, delivered by the 12 B modules, is a 36-MeV lithium ion beam which arrives at the target 20 ns later, delivering higher peak power (230 TW) over a shorter duration (8 ns).

\*This work was supported by the U.S. Department of Energy under contract DE-AC04-94AL85000.

## Report Documentation Page

*Form Approved*  
OMB No. 0704-0188

Public reporting burden for the collection of information is estimated to average 1 hour per response, including the time for reviewing instructions, searching existing data sources, gathering and maintaining the data needed, and completing and reviewing the collection of information. Send comments regarding this burden estimate or any other aspect of this collection of information, including suggestions for reducing this burden, to Washington Headquarters Services, Directorate for Information Operations and Reports, 1215 Jefferson Davis Highway, Suite 1204, Arlington VA 22202-4302. Respondents should be aware that notwithstanding any other provision of law, no person shall be subject to a penalty for failing to comply with a collection of information if it does not display a currently valid OMB control number.

1. REPORT DATE <b>JUL 1995</b>	2. REPORT TYPE <b>N/A</b>	3. DATES COVERED <b>-</b>	
4. TITLE AND SUBTITLE <b>The Light Ion Pulsed Power Induction Accelerator For ETF</b>		5a. CONTRACT NUMBER	
		5b. GRANT NUMBER	
		5c. PROGRAM ELEMENT NUMBER	
6. AUTHOR(S)		5d. PROJECT NUMBER	
		5e. TASK NUMBER	
		5f. WORK UNIT NUMBER	
7. PERFORMING ORGANIZATION NAME(S) AND ADDRESS(ES) <b>Sandia National Laboratories P. O. Box 5800 Albuquerque, NM 87185-1193</b>		8. PERFORMING ORGANIZATION REPORT NUMBER	
9. SPONSORING/MONITORING AGENCY NAME(S) AND ADDRESS(ES)		10. SPONSOR/MONITOR'S ACRONYM(S)	
		11. SPONSOR/MONITOR'S REPORT NUMBER(S)	
12. DISTRIBUTION/AVAILABILITY STATEMENT <b>Approved for public release, distribution unlimited</b>			
13. SUPPLEMENTARY NOTES <b>See also ADM002371. 2013 IEEE Pulsed Power Conference, Digest of Technical Papers 1976-2013, and Abstracts of the 2013 IEEE International Conference on Plasma Science. Held in San Francisco, CA on 16-21 June 2013. U.S. Government or Federal Purpose Rights License.</b>			
14. ABSTRACT <b>The light ion Engineering Test Facility (ETF) driver concept, based on Hermes III1 and RHEPP2 technologies, is a scaled-down version of the LMF3 design incorporating repetition rate capabilities of up to 10Hz. The preconceptual design presented here provides 250-TW peak power to the ETF target during 8 ns, equal to 2-MJ total ion beam energy. Linear inductive voltage addition driving a self-magnetically insulated transmission line (MITL) is utilized to generate the 36-MV peak voltage needed for lithium ion beams. The - 3-MA ion current is achieved by utilizing many accelerating modules in parallel. Since the current per module is relatively modest (- 300 kA), two-stage or one-stage extraction diodes can be utilized for the generation of singly charged lithium ions. The accelerating modules are arranged symmetrically around the fusion chamber in order to provide uniform irradiation onto the ETF target. In addition, the modules are fired in a programmed sequence in order to generate the optimum power pulse shape onto the target. This design utilizes RHEPP accelerator modules as the principal power source.</b>			
15. SUBJECT TERMS			
16. SECURITY CLASSIFICATION OF:			17. LIMITATION OF ABSTRACT <b>SAR</b>
a. REPORT <b>unclassified</b>	b. ABSTRACT <b>unclassified</b>	c. THIS PAGE <b>unclassified</b>	
			18. NUMBER OF PAGES <b>6</b>
			19a. NAME OF RESPONSIBLE PERSON

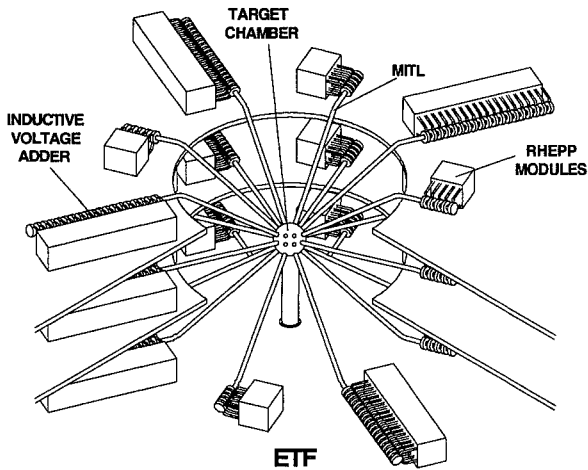

Figure 1. Cutaway view of the ETF Accelerator

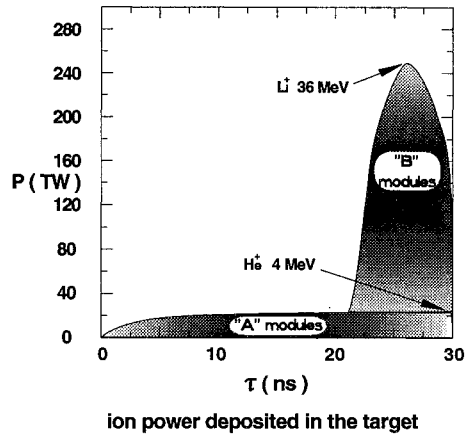

Figure 2. ETF target power requirements

### The ETF Accelerator

The ETF pulsed power concept is based upon the successful Hermes-III and Repetitive High Energy Pulsed Power (RHEPP) technologies developed at Sandia during the last few years. The Hermes-III voltage adder<sup>1</sup> generates a nominal 16-TW, 20-MV, 800-kA, 40-ns electrical pulse at a typical rate of about 5 shots per day. Each Hermes-III pulse forming line (PFL) supplies a 1-MV, 200-kA, 60-ns pulse to its respective inductive cavity (Hermes III has 20 cavities with 4 PFLs per cavity). This is done with a technology involving Marx generators, laser-triggered gas switching, and self-break water switching. We propose that the required ETF repetition rate of several Hz could be obtained by replacing each PFL of Hermes III with RHEPP technology (Fig 3).<sup>2</sup> In the new RHEPP technology, a motor driven alternator is the prime energy store, and metglas magnetic switches are used for pulse compression. The low energy RHEPP device has successfully operated at 120 Hz with 0.8-MV, 30-kA, 60-ns electrical pulses.<sup>2</sup> Thus, we believe that the basis exists for designing a 6 Hz ETF voltage adder via the combination of RHEPP and Hermes-III technologies.

Twenty-four modules are necessary to provide pulse uniformity on the target. Each module has its own diode producing 24 separate ion beams focused on the ICF target. The beams propagate fully space charge- and current-neutralized in a 1 Torr helium atmosphere. The helium and lithium beams are bunched by a factor of 2 and 2.5, respectively, during transport to the target by ramped voltage pulses. The ion diodes can be single or double stage (the latter will require a triaxial voltage<sup>4</sup> adder for each module). The power of the ions delivered to the target is shown in Fig. 2. The electrical power delivered by the voltage adders to the diodes is somewhat higher due to certain inefficiencies in the diode and in the transport system. We assume a 70% unbunched peak power efficiency from the diode to the target. Hence, the A modules deliver to

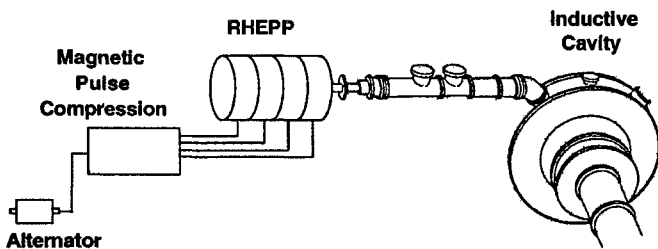

Figure 3. The ETF pulsed power concept

the diodes a total peak electrical power of 14 TW and the B modules of 130 TW. Table I summarizes the electrical output parameters for both types of modules.

**Table I**  
**Electrical Output Parameters per Module**

	Module A	Module B
P (TW)	1.2	10.8
V (MV)	4	36
I (kA)	300	300
$\tau$ (ns)	60	20
W (MJ)	.74	.21

Recall that the A modules accelerate helium ions while the B modules accelerate lithium ions, and hence the required kinetic energies differ.

### Accelerating Module Design

Each voltage adder of the 24 modules is connected to the corresponding diode via a long extension magnetically insulated transmission line (MITL) which time-isolates the diode from the voltage adder. Thus the diode can operate at lower impedance than the voltage adder without affecting the voltage adder operation. Undermatching the diode load reduces the sheath electron current in the extension MITL and improves pulse power coupling efficiency.

The ETF driver can be built with inductive cavities similar or identical to those of SABRE or Hermes III. The 12 low power modules A are each one-half of the SABRE accelerator with only 5 out of the total ten SABRE cavities. Each of the five cavities are fed by one 1-MV RHEPP accelerator with a repetition rate that has been reduced from 120 to 6 Hz.

The B modules have two stages. We analyzed two design options for the first and second stages: one that is composed of SABRE or Hermes-III 1-MV cavities and the other made up of 2.5-MV cavities, both driven by one RHEPP accelerator per cavity. Thus, the B module can be built by 4.7 SABRE accelerators connected in series (47 cavities in total) or by nineteen 2.5-MV cavities.

Table II summarizes the design of both A and B modules. A third option is a combination of the previous two: it consists of 12 SABRE cavities for the first stage and fourteen 2.5-MV cavities for the second stage.

**Table II****ETF Module Design Summary**

	MODULE A	MODULE B	
		FIRST STAGE	SECOND STAGE
Type of cavities	1-MV	1-MV or 2.5-MV	1-MV or 2.5
Number of cavities	5	12 or 5	35 or 14
RHEPP current (kA)	350	350	350
Number of RHEPP/cavity	1	1	1
Rep. rate (Hz)	6	6	6
Diode Current (kA)	286	294	294
Diode Voltage (MV)	4.2	9.6	27.3
Z <sub>DIODE</sub> ( $\Omega$ )	14.7	32.6	92.8

The design assumes a ~ 69% efficiency between the total power input into the voltage adders and the usable electrical output power delivered to the ion diodes. This efficiency estimate includes an additional 15% loss due to the positive polarity operation. The existing Hermes III routinely operates in the higher efficiency negative polarity mode and SABRE in the lower efficiency positive polarity mode.

**Repetitive Pulsed Power for ETF**

The RHEPP accelerator, although utilized in this application as a prime pulsed power source, is actually a linear induction voltage adder. The 1-MV model has 5 inductive cavities, each fed by a 200-kV pulse. The power pulse is produced by a cascade of magnetic switches which compress the 120-Hz CW pulses from a motor-driven alternator to a 60-ns final pulse width. The RHEPP voltage adder operates below the self-magnetic insulation limit and hence utilizes oil to insulate the cathode electrode from the anode.

At present a RHEPP module with four cavities has successfully operated for 130,720 shots (~ 18 minutes). At that time all components had achieved thermal equilibrium at or below design temperature limits. It produced 800-kV, 30-kA pulses with 84% efficiency. In the present ETF design, we assume a repetition rate of 6 Hz. Hence, the peak current could be increased by a factor of 20 without the need of additional cooling. However, to be conservative, we limit the current flowing through the RHEPPs to 350 kA, about half of the 600-kA maximum allowed at 6 Hz operation.

The 2.5-MV RHEPP model is also operational and provides similar pulse lengths and current output. The voltage adder is in vacuum and is self-magnetically insulated. Thus, the proposed repetitive pulsed power technology for ETF is presently available, and no large technological extrapolations were assumed in our conceptual design.

## Beam Generation and ETF Transport

Our ETF intense light ion beam generation concept is based upon a combination of “single shot” ion diode technologies under development in the PBFA-II<sup>5</sup> and SABRE<sup>6</sup> facilities at Sandia and the repetitive ion diode technologies being developed in conjunction with the RHEPP capability.<sup>7</sup> At present, PBFA II is capable of generating a  $\sim 10$ -TW, 10-MeV lithium ion beam in a single shot applied-B barrel diode. A high power applied-B extraction lithium ion diode is being developed on a single shot basis in the SABRE facility and in PBFA II (PBFA II-X). With RHEPP technology as a driver, repetitive ion diodes are currently being developed by Cornell and Sandia at the  $\sim 0.1$ -TW, 1-MeV (protons), 40-ns level. The first repetitive version of this diode has been operated in bursts at up to a 100 Hz repetition rate.<sup>7</sup> A substantial development program could lead to a high power repetitive ion diode driven by a ETF module at the  $\sim 10$ -TW, 30-MV, 40-ns per pulse level.

Self-pinch ion beam propagation is the most attractive concept for providing ion diode standoff from the ICF blast and radiation effects in an ETF application. In this scheme, each ion beam is ballistically focused down to a small radius (less than 1 cm), and then transported in the self-pinch mode at small radius for several meters to the target (Fig. 4). The target chamber fill gas parameters are chosen so that the beam is current neutralized to  $\sim 90$ -98%. The net current forms an azimuthal field that confines the beam. IPROP simulations of self-pinch transport are encouraging.<sup>8</sup> Experiments to demonstrate self-pinch transport on the SABRE accelerator are being planned.

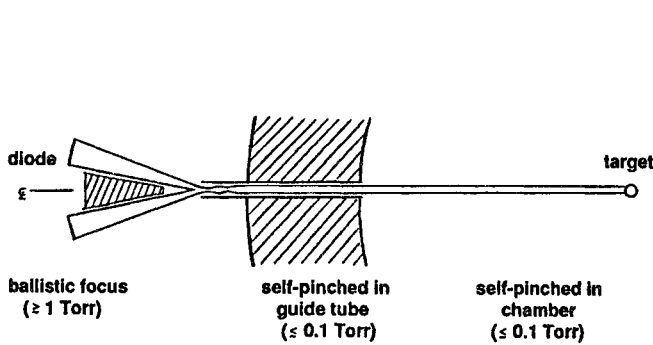

Figure 4. Self-pinch ion beam propagation

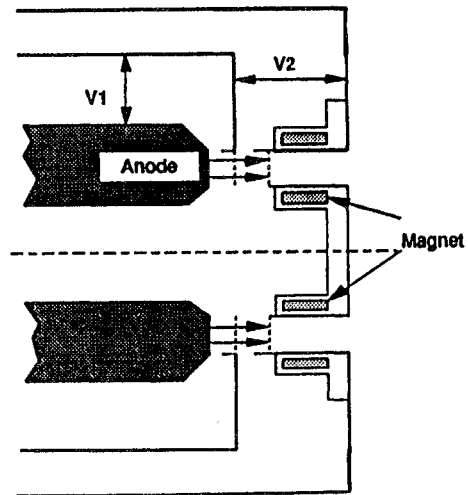

Figure 5. The two-stage extraction ion diode concept

The transport distance provides a means to use velocity ramping and beam bunching to obtain a factor of 2 - 2.5 increase in beam intensity on target. Intrinsic to this concept is the need for an accurately programmed voltage pulse and a transport length of about 4 meters. Our approach to a low-divergence, programmed-voltage ion diode involves the two-stage diode technology under development at Sandia.<sup>9</sup>

A schematic of the geometry for the two-stage extraction ion diode is shown in Fig. 5. A single magnetic field region used to insulate against electron flow across the gap is divided into two accelerating regions by the addition of a mid-gap electrode. The beam is allowed to propagate to the second gap by making the mid-gap electrode from a mesh or a thin foil. The electrode allows beam transport between stages but isolates the accelerating electric fields, the beam magnetic

field, and the diamagnetic effects of the gap electrons in the two gaps. In the first stage the ion current is limited only by the ion space charge and the effective anode-cathode gap. In the second stage, the ion current is limited by the injected current from the first stage (assuming the electrode does not emit a significant ion current). Separation of the electron dynamics in the two stages can lead to a divergence reduction in the second stage.

## Conclusions

This ETF accelerator design is based on the robust Hermes-III and the proven RHEPP technologies. It has flexible modular configuration which offers risk control by an anticipated staged construction. Half of the 24 modules are identical to SABRE and the other half can be built with SABRE or similar 2.5-MV components. RHEPP accelerator units are utilized as prime power source replacing the conventional Marx generators and pulse forming lines. The pulsed power technology is currently available, and no large extrapolation from the present state of the art is required. Among the items that need substantial research and development are the repetitive ion source, and the transport and focusing of the ion beam onto the ICF target from a stand-off distance of  $\sim 4$  m.

## References

1. J. J. Ramirez, et al., "Hermes-III—A 16-TW, Short Pulse Gamma Ray Simulator," *Proc., 7th International Conference on High Power Particle Beams*, Karlsruhe, Germany, July 4-8, 1988, pp. 148-157.
2. D. L. Johnson, et al., "Results of Initial Testing of the Four-Stage RHEPP Accelerator," *Proc., 9th IEEE International Pulsed Power Conference*, Albuquerque, New Mexico, June 21-23, 1993, pp. 437-440, IEEE number 93CH3350-6.
3. M. G. Mazarakis, et al., "The Light-Ion Pulsed Power Induction Accelerator for the Laboratory Microfusion Facility (LMF)," *Proc. of the IEEE Particle Accelerator Conference*, Washington, D. C., May 17-20, 1993, pp. 667-669, IEEE number 93CH3279-7.
4. M. G. Mazarakis, et al., "The LMF Triaxial MITL Voltage Adder System," *Proc. 9th IEEE Pulsed Power Conference*, Albuquerque, NM, June 21-23, 1993, pp. 427-430, IEEE number 93CH3350-6.
5. T. A. Mehlhorn, et al., "Lithium Beam-Driven Target Experiments at  $10^{15}$  W/g on PBFA-II," *Proc. 11th International Workshop on Laser Interaction*, Monterey, CA, October 25-29, 1993.
6. M. E. Cuneo, et al., "Observation of Reflected Waves on the SABRE Positive Polarity Inductive Adder MITL," *Proc. 9th IEEE Pulsed Power Conference*, Albuquerque, NM, June 21-23, 1993, pp. 423-426, IEEE #93CH3350-6.
7. R. W. Stinnett, J. B. Greenly, et al., *Proc. IEEE Conference on Plasma Science*, Santa Fe, NM, 1993, pp. 114-115.
8. D. R. Welch, Mission Research Corporation, private communication (1994).
9. T. R. Lockner, S. A. Slutz, "Recent Results in 2-Stage Diodes at Sandia National Laboratory," *Proc. 11th International Workshop on Laser Interaction*, Monterey, CA, October 25-29, 1993.