

Design of a Driver for the Cygnus X-ray Source

D. Weidenheimer, P. Corcoran, R. Altes, J. Douglas, H. Nishimoto, I. Smith,
R. Stevens, D.L. Johnson, R. White
Titan-Pulse Sciences Division

J. Gustwiller, J.E. Maenchen, P. Menge
Sandia National Labs

R. Carlson, R. D. Fulton
Los Alamos National Labs

G. Cooperstein
Naval Research Lab

D. Droemer, E. Hunt
Bechtel Nevada

Abstract

Cygnus is the prototype of a radiographic x-ray source leveraging existing hardware and designs to drive a rod-pinch diode at 2.25 MV. This high-resolution x-ray source is being developed to support the Sub-Critical Experiments Program (SCE) at the Nevada Test Site (NTS), and as such employs a modular technology that is scaleable to higher voltages and can be readily deployed underground. The diode is driven by three Induction Voltage Adder (IVA) cells from the Sandia SABRE [1] accelerator, threaded by a positive polarity vacuum coax that extends 2 meters to the diode and is designed to operate below electron emission on the anodized outer electrode. The ~ 40 ohm diode impedance requires a $40/3^2$ or ~ 4.5 ohm source to drive the three IVA cavities in parallel; a convenient impedance for a single water coax. The water coax is designed to function as a two-step impedance transformer as well as a long, passive water cable, accommodating several bends along its length. The latter feature allows independent positioning of the pulsed power driver, IVA and diode x-ray source. The long water coax is driven by a PFL originally developed for Sandia's Radiographic Integrated Test Stand (RITS) [2] and a low-inductance commercial Marx charges the single PFL. The accelerator design is a result of a cooperative effort by Titan-PSI and Maxwell (now collectively Titan-PSD) SNLA, LANL, NRL, and Bechtel-Nevada.

Application and System Overview

Since the ultimate application is radiography of sub-critical testing, the design of the prototype incorporates all features necessary for operation in a space-constrained, down-hole environment. The SCE application actually requires that two identical, but independently timed, x-ray sources (and therefore accelerators) be placed side-by-side in a tunnel with their radiographic axes angled at 120 degrees to each other, and each pointing at a common

target one meter away. The source development program leverages existing designs and hardware whenever possible. This led to the use of three existing SABRE cells in the IVA, and to the use of a modified RITS PFL to drive the cells through a water cable and oil manifold.

A rod-pinch diode [3] was chosen for its ability to produce a sub-millimeter spot size x-ray source at the required end-point energy of 2.25 MeV and 5-10 rads (Si) dose at 1 meter. The rod-pinch diode geometry mandates that the vacuum coax be driven center conductor positive and that it be non-emitting, hence a vacuum insulated transmission line (VITL). Also of concern to the diode performance are the magnitude and characteristic polarity (mono or bi-polar) of any prepulse.

The accelerator design evolved over a period of some 12 months and includes features derived from a concurrently run set of rod-pinch diode experiments at SNLA on a modified SABRE test bed. Information on space and access constraints at the NTS SCE facility was continually updated during the design so that the prototype would accommodate the latest down-hole layout. The pulse length (70 nsec) was chosen initially to fully utilize the available V-sec product (~ 52 mV-sec) in the SABRE cores, assuming 750 kV per cell, and was implemented by shortening the RITS PFL 5.5 inches (8 ns, two-way). From the SABRE experiments the diode impedance was characterized at a nominal 40 ohms, but drooping to as little as 30 ohms by the end of the pulse. Commensurately, the diode current is ~ 60 kA, rising to 75 kA. The driver was designed to compensate for this drooping load impedance by profiling the PFL along its length. The Cygnus PFL is conveniently separated from the adder cells by a long water coax. This enables the PFL and Marx to be located in a drift (tunnel) remote from the one containing the IVA. The water coax also provides two steps (5.85 and 4.16 ohms) of a three-step impedance transformation between the output line of the PFL (7.8

Report Documentation Page

Form Approved
OMB No. 0704-0188

Public reporting burden for the collection of information is estimated to average 1 hour per response, including the time for reviewing instructions, searching existing data sources, gathering and maintaining the data needed, and completing and reviewing the collection of information. Send comments regarding this burden estimate or any other aspect of this collection of information, including suggestions for reducing this burden, to Washington Headquarters Services, Directorate for Information Operations and Reports, 1215 Jefferson Davis Highway, Suite 1204, Arlington VA 22202-4302. Respondents should be aware that notwithstanding any other provision of law, no person shall be subject to a penalty for failing to comply with a collection of information if it does not display a currently valid OMB control number.

1. REPORT DATE JUN 2001	2. REPORT TYPE N/A	3. DATES COVERED -			
4. TITLE AND SUBTITLE Design of a Driver for the Cygnus X-ray Source		5a. CONTRACT NUMBER			
		5b. GRANT NUMBER			
		5c. PROGRAM ELEMENT NUMBER			
6. AUTHOR(S)		5d. PROJECT NUMBER			
		5e. TASK NUMBER			
		5f. WORK UNIT NUMBER			
7. PERFORMING ORGANIZATION NAME(S) AND ADDRESS(ES) Titan-Pulse Sciences Division		8. PERFORMING ORGANIZATION REPORT NUMBER			
9. SPONSORING/MONITORING AGENCY NAME(S) AND ADDRESS(ES)		10. SPONSOR/MONITOR'S ACRONYM(S)			
		11. SPONSOR/MONITOR'S REPORT NUMBER(S)			
12. DISTRIBUTION/AVAILABILITY STATEMENT Approved for public release, distribution unlimited					
13. SUPPLEMENTARY NOTES See also ADM002371. 2013 IEEE Pulsed Power Conference, Digest of Technical Papers 1976-2013, and Abstracts of the 2013 IEEE International Conference on Plasma Science. IEEE International Pulsed Power Conference (19th). Held in San Francisco, CA on 16-21 June 2013. U.S. Government or Federal Purpose Rights License., The original document contains color images.					
14. ABSTRACT Cygnus is the prototype of a radiographic x-ray source leveraging existing hardware and designs to drive a rodpinch diode at 2.25 MV. This high-resolution x-ray source is being developed to support the Sub-Critical Experiments Program (SCE) at the Nevada Test Site (NTS), and as such employs a modular technology that is scalable to higher voltages and can be readily deployed underground. The diode is driven by three Induction Voltage Adder (IVA) cells from the Sandia SABRE [1] accelerator, threaded by a positive polarity vacuum coax that extends 2 meters to the diode and is designed to operate below electron emission on the anodized outer electrode. The ~40 ohm diode impedance requires a 40/32 or ~4.5 ohm source to drive the three IVA cavities in parallel; a convenient impedance for a single water coax. The water coax is designed to function as a two-step impedance transformer as well as a long, passive water cable, accommodating several bends along its length. The latter feature allows independent positioning of the pulsed power driver, IVA and diode x-ray source. The long water coax is driven by a PFL originally developed for Sandia's Radiographic Integrated Test Stand (RITS) [2] and a lowinductance commercial Marx charges the single PFL. The accelerator design is a result of a cooperative effort by Titan-PSI and Maxwell (now collectively Titan-PSD) SNLA, LANL, NRL, and Bechtel-Nevada.					
15. SUBJECT TERMS					
16. SECURITY CLASSIFICATION OF:			17. LIMITATION OF ABSTRACT	18. NUMBER OF PAGES	19a. NAME OF RESPONSIBLE PERSON
a. REPORT unclassified	b. ABSTRACT unclassified	c. THIS PAGE unclassified	SAR	5	

ohm) and the load. The final step occurs at the IVA, where a ~ 3.2 ohm equivalent impedance for the load represents the worst case for the diode plus the magnetizing losses in the magnetic cores.

An oil manifold assembly connects the water cable to the IVA cells. It is relatively short with respect to the pulse risetime, making its impedance non-critical, and the resulting electrical design was driven mostly by electric field management. The impedance of the vacuum coax was chosen to be 40, 60 and 60 ohms through successive cells. Because the transit times through the cells in the vacuum are short, the system performance is rather insensitive to the actual vacuum impedances. The particular values were chosen to keep the electric field on the outer below the threshold for electron emission. The length of VITL between the last cell and diode is under 2 meters. Figure 1 shows a simplified electrical schematic of the accelerator.

The overall reliability of the accelerator was specified at better than one failure in 200 ($> 99.5\%$) including pre-fires, no-fires and breakdowns. Therefore the probability of breakdown ($P = 0.5 f^{l/m}$, where f is the fraction of breakdown defined by the single-shot formulae and m is the area exponent) anywhere in the machine needs to be at least one order of magnitude below this requirement so as to be an insignificant contributor. Consequently, electric fields everywhere in the liquid dielectrics are below 60% of E_{BD} , as defined by the Aldermaston single-shot formulas and modified by NRL in the case of water. The allowable electric fields in the vacuum were the subject of much conjecture during the design because very little data exists at comparable areas for any of the candidate materials and/or surface treatments. A discussion of the vacuum electric field criteria is included under the cell and VITL design section of the paper.

The layout of the Cygnus accelerator can be seen in Figure 2. The Marx and PFL are located remote from the

skid-mounted IVA, VITL and diode, and coupled by a water coax.

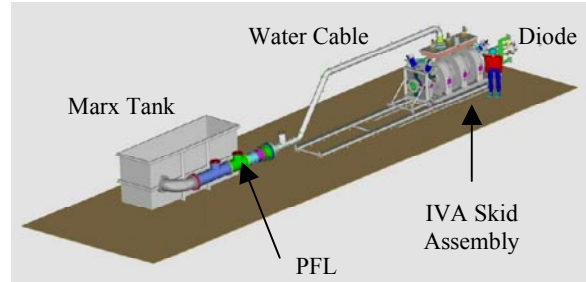

Figure 2. Cygnus accelerator layout.

Marx Generator

The Marx charges the PFL directly in Cygnus. A charge time of ~ 350 ns is necessary for the PFL and its charging system to remain below 60% of E_{BD} . An erected Marx capacitance of 6 nF was chosen to slightly overmatch the capacitance of the PFL in combination with the Marx strays and PFL connection. The series equivalent inductance for this Marx needs to be 5 μH or less in order to achieve the requisite charge time. The erected voltage needs to be -3.1 MV at maximum for a planned 10% margin above the required -2.75 MV peak predicted by the model.

Two commercial Marx designs were evaluated for the prototype, a PSI TRIMEV-style Marx and a commercial design from the former Maxwell/PI. A TRIMEV-style Marx has an advantage in lower series inductance, but the Maxwell/PI unit was chosen because it employed higher energy density capacitors and was easily expandable to higher energy (capacitance) per stage, a feature considered important for future applications. The final design employed General Atomic Energy Products Type SS capacitors rated at 200 nF and 100 kV each, and Maxwell/PI Part No. 40264 spark gaps. There are 32 full 100 kV stages and two 50 kV half stages, and the equivalent series resistance of the Marx is predicted to be from 2 to 4 ohms.

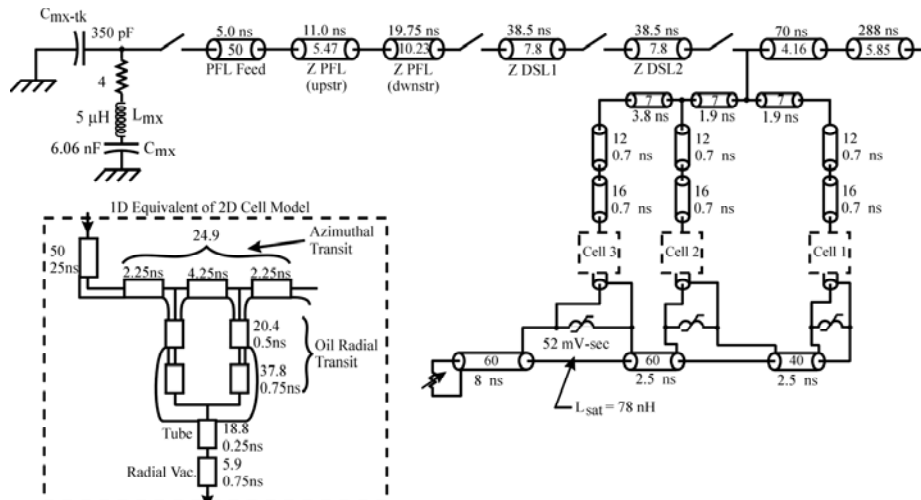

Figure 1. Simplified accelerator schematic.

The Marx tank design is necessarily compact owing to down-hole handling issues, thus requiring careful placement of components at its output end. The Marx is hung from the tank lid via nylon straps and the lid lifts from the tank, allowing access to the Marx, via hydraulic jacks positioned at each corner. A pivoting swing-arm connects the Marx to a 28 ohm $(L_{\text{marx}}/C_{\text{marx}})^{1/2}$ clamping resistor during the charge sequence, limiting the voltage at the output node of the Marx to ~53% of charge if fired into the clamp. Marx diagnostics consist of a CVR at the ground end, and a liquid resistive voltage monitor connected to the roll-up at the output end. Down-hole footprint constraints placed the Cygnus PFL alongside the Marx tank.

Modified RITS PFL

The Cygnus PFL has a 35 nsec one-way transit time, a stepped impedance from 10.23 to 5.47 ohms, and presents a 4.5 nF capacitance to its charging circuit. The oil prepulse switch at the end of the RITS PFL was redesigned to interface with the Cygnus water cable, but the PFL switch, transfer lines, and sharpening switch remain unchanged. Our model predicts a PFL output pulse of magnitude 1.4 MV, rising in 10-12 nsec, for a Marx charge voltage of ± 38 kV. The model also predicts a prepulse of less than ± 10 kV upstream of the prepulse switch and ± 2 kV or less downstream. Diode experiments on the modified SABRE demonstrated little sensitivity to a mono-polar prepulse of as much as +40 kV (two percent of operating voltage). It remains uncertain, however, as to how the diode will respond to a bipolar prepulse of such magnitude as would be transmitted in the absence of the oil prepulse switch. Experiments will be performed to determine the necessity of the prepulse switch during the prototype evaluation and it may be eliminated from the down-hole systems. The pulse line diagnostics are basically the same as in the RITS design with the exception that all diagnostics adopted an SNLA standard boss. Specifically, there is one V-dot and one B-dot set at each of four locations along the line; two sets on the actual PFL and one set on each of the next two lines. A dummy load, as designed by SNLA for RITS, was modified for use in testing the Cygnus Marx and PFL and is to be instrumented for voltage and current with an integral liquid resistive divider and CVR.

Water Transmission Line/Transformer and Diverter Switch

A water-filled coax was chosen to couple the PFL and IVA because it has the capability to reliably transport the energy at the required voltage for the 3-cell IVA while transforming impedance in several steps along its length. Both aluminum and stainless steel were evaluated for construction of the coax. The length of the coax needed to be at least 20 meters for the down-hole system. Stainless steel was chosen for its ability to support > 15 M Ω -cm water easily and thereby minimize shunt losses along the coax length. Series losses are greater than that for

aluminum, but scale as $(\rho_2/\rho_1)^{1/2}$, as opposed to shunt losses that scale linearly with water resistivity. Stainless is also superior from a structural standpoint. A three-step transformation was chosen because it was easily implemented and resulted in a ~94% energy transfer versus ~90.5% for a two-step. The actual impedance values (7.8, 5.85, 4.16, 3.2) differ slightly from the relationship $Z_s/Z_1 = Z_1/Z_2 = Z_2/Z_L = (Z_s/Z_L)^{1/3}$ because standard tubing sizes were used. Most of the length of the water coax is at 5.85 ohms with the transition to 4.16 ohms occurring at ~2 meters from the oil manifold. This more or less balances the electric field stresses between the inner and outer for most of the coax length.

The output end of the water coax terminates in a double diaphragm at the oil manifold. This connection can be disassembled by draining a small volume of water between the diaphragms, while the manifold and water coax remain full. Integral diagnostics consist of V-dot and B-dot probes at several locations along the line.

There are two independent causes of reflected energy in the accelerator, diode impedance collapse and core saturation. In the model, the two combine to create reverse polarity spikes of under 10 ns duration but with a magnitude of as much as 80% that of the forward-going pulse. According to the model, the most stressed node is the reverse transition from water cable to PFL (5.85-7.8 ohms). An initial assumption was made that because the design stresses for the forward going pulse are modest (~45% of E_{BD}), then the forward and reflected (reverse polarity) pulse could be treated as statistically independent. Without operational experience to verify this, and because of concern for the plastic diaphragms, it was decided to include a self-closing diverter switch along the water coax. The switch provides adjustable enhancements on both negative and positive electrodes; a feature thought necessary for flexibility in operation. There is a resistance of ~3 ohms in series with the diverter gap. The thermal capacity of the resistor pack is such that it can absorb up to the full forward energy of the system in the event that the gap closes early. The diverter is also designed as a modular assembly so that it can simply be removed if it is found to be unnecessary for system operation.

A single de-ionizing system is shared between the PFL and water coax. In addition to de-ionizing, the system filters and de-aerates. The failure of some RITS PFL diaphragms (at 10% higher voltage stresses than will be employed here) has recently been linked to bubble formation. The addition of a de-aeration circuit to the system alleviated the problem, thus reinforcing the decision to de-aerate on Cygnus. The throughput capacity of the system is specified to be at least 10 GPM in order to assure high quality water throughout the PFL and water coax.

Oil Manifold

An oil manifold connects with the water coax and distributes the pulse to all three IVA cells. A flat, rectangular cross-section design was developed that fits within the allowable down-hole space. The actual impedance of the manifold along its length is ~ 7 ohms and the feeds to the individual cells are ~ 16 ohms. The water coax enters midway between the first and second cell feeds, a best compromise for the transit time difference between oil and vacuum, and results in minimal perturbation to the pulse leading edge.

The manifold mechanical design was challenging because of a number of unique features specific to the application. The first of these is that the entire assembly is tilted 3 degrees off horizontal to allow bubbles to escape from the bottom surfaces of the inner and outer conductors. A second mechanical design challenge involved the reset circuitry for the cores. Because the Cygnus IVA is manifold-fed (rather than each cell driven from individual PFLs) provision must be made to assure each set of cores receive adequate reset current. A plunger mechanism that breaks the connection from the manifold inner to the cell feeds was adopted. Integral to the plunger is an electrical contact for delivering reset current to the isolated cell.

IVA Cells

The SABRE cells were originally designed to be fed from two points spaced 180 degrees apart. There was however insufficient space down-hole for this to be implemented. A two dimensional model of the SABRE cell was constructed and showed no significant degradation in risetime or pulse shape when using a single feed. Furthermore, since the accelerator does not depend on magnetic insulation for vacuum power flow, current non-uniformity in the radial feeds and VITL is not of concern. The 2-meter distance downstream of the last cell is more than sufficient for the current flow to homogenize around the coax before reaching the diode. Figure 3 shows a cross section of the IVA Cell-VITL-Diode assembly on its skid mount.

There are four tape wound magnetic cores (not shown in assembly) in each SABRE cell. The SABRE core specification is for 13.0 mV-sec each of 2605CO material. The cores were characterized by the manufacturer under DC conditions and averaged just less than 13 mV-sec.

Some of the SABRE cells contained cores from the original HELIA [4] program. These cores were wound from 2605SC material and were found to have about half the flux swing of a comparable SABRE spec core when tested on a microsecond test stand. The HELIA cores were therefore set aside and only SABRE spec cores used in Cygnus.

For a system using three of the SABRE IVA cells to achieve an output voltage of 2.25 MV, our modeling predicts peak cell voltages of ~ 950 kV. The 21% voltage loss from the sum of the impressed voltages to the diode is due to the $L di/dt$ drops between cells and along the length of VITL between the last cell and the diode. With a maximum of 52 mV-sec of magnetic isolation per cell, it would seem that core saturation should shorten the pulse to the diode by as much as 25%. However, our circuit model, which includes a benchmarked core model, predicts a diode pulse of ~ 65 nsec duration. This is partly due to the cores' fast saturation characteristics (non-square B vs. H) and partly to the non-zero saturated inductance of the cells.

In order to control electron emission from negatively stressed surfaces within the accelerator, clear hard anodizing is applied to any surface on which the electric field is greater than -150 kV/cm. Furthermore, the maximum field on any negatively stressed surface in the vacuum is 200 kV/cm. These are conservative stresses based on previous work by Frazier [5] and experience with the HELIA [4] and TRIMEV [6] accelerators. Meeting these criteria required designing a new radial vacuum feed for the cells. The radial feed electrode disc was re-designed with an increased radius on the negatively-stressed vacuum side, and the vacuum insulator was re-graded (to within $\pm 5\%$) with the inclusion of a field shaper in the oil. The grading rings were all re-cut to SNLA's specification that tapers and moves the step on the positive grading ring surface away from the triple point. The rings were then hard anodized; a practice that is thought to be beneficial in reducing breakdowns on the vacuum side of the insulator stack.

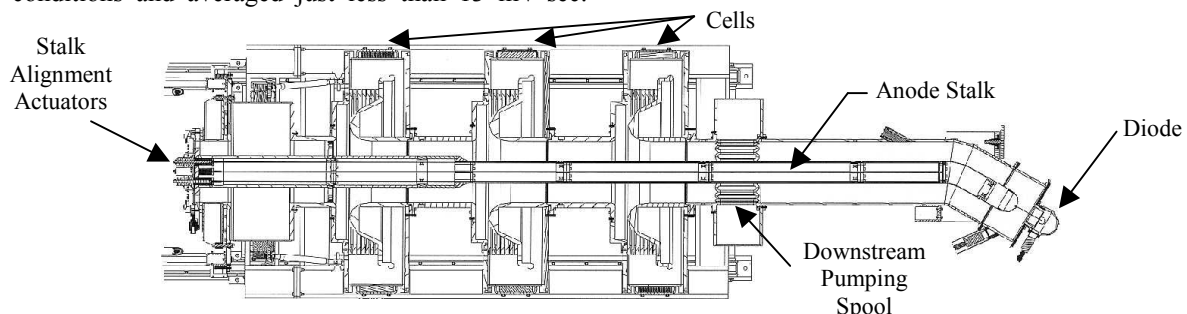

Figure 3. IVA skid assembly cross-section.

VITL and Diode

The cells, VITL and diode are all part of a skid assembly that moves along a set of rails for serviceability (shown in Figure 2). The Cygnus IVA cells were designed with new features that allow in situ inspection and cleaning of the vacuum insulator stacks. Removable endplates slide over the inter-cell spools, allowing this access.

In order to meet the vacuum pumping specification for a complete pump-down in less than one hour, the downstream pumping spool needed at least 50% transparency. Because this spool is downstream of the final cell (full IVA voltage), control of electric fields was difficult and compound radii were used on the slot edges. Furthermore, the spool was designed with the pumping slots on a removable hard anodized liner that can be removed and re-worked if necessary. Specifying the vacuum system for the accelerator required the construction of a SPICE model using analogous electrical components for gas sources and conductances. The model pointed out the need for pumping both ends of the IVA, with two CT8 cryo-pumps at each end.

The VITL's cantilevered inner stalk is ~ 5 meters long and includes two steps along its length. The first step is for the current contact upstream of the first cell. The second step transitions the VITL from 40 to 60 ohms just upstream of the second radial feed. According to the circuit model, the output pulse is rather insensitive to the actual VITL impedance profile. The only significant effect is to the peak cell voltage and consequently the time to saturation of the cores. The 40 to 60 ohm impedance transition was chosen to control electric fields on the negative outer. In addition to serving its electrical purpose, the stalk is used to align the rod pinch diode and ultimately define the radiographic axes of the experiment. A ~1 mm diameter rod is mounted on the end of the stalk in the center of a hemispherical termination. The rod must align with the center of a ~10 mm diameter hole in the cathode plate. Cameras downstream of the diode, looking along the radiographic axis through mirrors, monitor alignment. The stalk is manipulated via a system of cables that attach to the stalk ground end plate and the other end just upstream of the hemisphere. The cables are tensioned to bend the stalk slightly for fine adjustments to the rod position. Adjustments are also made by deflecting the stalk endplate with a system of differential screws. The entire stalk is cantilevered from this endplate and rolls away from the assembly for servicing, on captive rail bearings.

The Cygnus diode design, provided by Sandia, is expected to be a slight variant on the diode that has been extensively characterized on the modified SABRE test bed. Refurbishment of the diode is performed by separating the last section of the VITL outer from the assembly and moving it forward to clear the hemisphere.

Status

The Cygnus design is essentially complete and hardware is being assembled. Tests of the Marx and pulseline are under way at Los Alamos. The IVA is being assembled at Titan-PSD after refurbishing the SABRE parts, and its mechanical and vacuum features will be demonstrated before shipping to Los Alamos. The water coax will also be assembled at PSD before shipment. Cygnus will be tested in building SM316 and then moved to a firing point at Los Alamos for further demonstration. Two additional systems, incorporating lessons learned from the prototype and all the necessary down-hole features, will then be procured and assembled for use at NTS.

References

- [1] "SABRE, A 10 MV Linear Induction Accelerator", J.P. Corley, et. al., 8th IEEE Int. Pulsed Power Conf. Proceedings, San Diego CA, 1991, pp 920-923
- [2] "Design of a Radiographic Integrated Test Stand (RITS) Based on a Voltage Adder, to Drive a Diode Immersed in a High Magnetic Field", I.D. Smith, et. al., IEEE Trans. on Plasma Science, Vol. 28, No. 5, Oct. 2000
- [3] "Theoretical Modeling and Experimental Characterization of a Rod-Pinch Diode", G. Cooperstein, et. al., to be published in the Physics of Plasmas, Oct. 2001.
- [4] "The Four Stage HELIA Experiment", J.J. Ramirez, et. al., 5th IEEE Pulsed Power Conf. Proceedings, Arlington VA, 1985, pp 143-146
- [5] "Pulsed Electron Field Emission from Prepared Conductors", G. B. Frazier, 2nd IEEE Int. Pulsed power Conf. Proceedings, Lubbock TX, 1979, pp 127-131
- [6] "TRIMEV 3MV Radiographic Flash X-Ray Generator", PSI-O&M-1513, May 1990, prepared for CEA, France.