

Abstract

The triggered gas switches in PBFA I were recently changed from a single gap trigatron design to a 15-stage cascade design with a relatively short triggered gap. This improved design provides a low jitter value and has an extremely low probability of prefire. The triggered section represents about one-third of the total voltage of the switch and is triggered with a pin configuration similar to the previous trigatron design. The fields in the triggered gap were adjusted to allow prompt triggering and yet avoid prefires in the trigger gap at the operating gas pressure. Operating parameters of the switch will be discussed along with an analysis of the improved machine performance with respect to jitter, prefire probability, and operating voltage.

Introduction

PBFA I, being the only operational pulse power machine with a large number of independent modules, has a uniquely stringent requirement for timing control. The final command triggered stage in the pulse compression process is the triggered gas switch which starts the energy transfer from the intermediate store to the pulse-forming line. Until recently the gas switch was a two electrode design with a pin-in-hole electrical trigger known as a trigatron. This switch has proven very useful in a number of applications, but was somewhat ineffective in the 36-line environment because of a relatively low, but unacceptable, probability of prefire. The probability of prefire for any one switch per shot was less than .05, but this results in a probability for the 36 module ensemble of near unity for each shot.

Several years ago, development began on a multistage switch, which would provide a lower probability of prefire while maintaining or improving the low jitter performance of the trigatron. The switch which evolved from this process is illustrated in Fig 1. The primary design considerations included an extremely low probability of prefire, nearly uniform fields, low peak fields, tight self break distribution, and good trigger control.

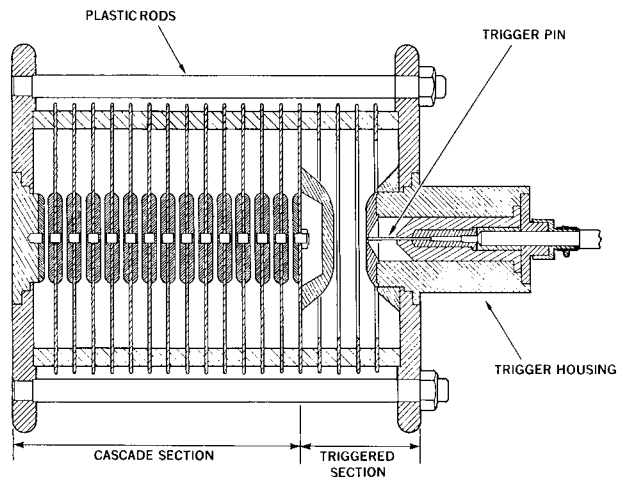

Figure 1. Cascade gas switch with associated trigger pin assembly.

*This work supported by the United States Department of Energy under Contract number DE-AC04-DPO0789.

Design Description

The cascade switch design consists of 14 untriggered gaps and a single triggered gap with nominal spacings of 0.250 and 1.5 inches respectively. The triggered gap is comprised of electrode assemblies which minimize the field enhancement near the surfaces. The untriggered gap electrodes have flat surfaces with radiused edges. The housing of the cascade switch has the same nominal dimensions as the former trigatron switch except that the trigger pin assembly must now protrude outside the envelope. The electrodes were manufactured of Type 304 stainless steel which was heat treated to clean and soften the surface, and bead blasted with glass beads to provide uniform field emission. The polymethylmethacrylate (lucite) insulators forming the housing were reconditioned parts from the previous trigatron units. The entire trigger pin assembly design remained the same as in the trigatron except for the outer housing which allows the assembly to reside outside the main switch instead of within the anode.

The electric fields in the immediate vicinity of the cascade switch in the PBFA I geometry are indicated in the equipotential plot of Fig. 2. A field shaper was required in this geometry to increase the fields toward the anode to give a more nearly uniform distribution of field within the switch. The field shaper as indicated in Fig. 2 consists of a ring attached to the intermediate store inner cylinder.

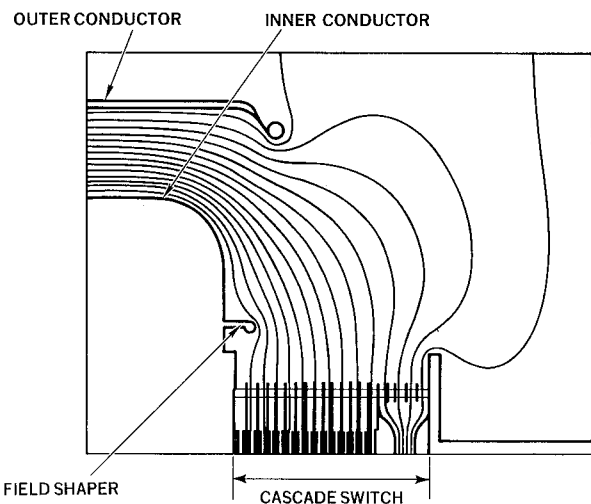

Figure 2. Equipotential plot of the cascade switch region in the PBFA I configuration. The intermediate store is indicated with an associated field shaper ring.

The maximum field enhancement factor in the triggered gap is about 1.1. The electric fields near the center line of the gaps are plotted in Fig. 3 with a nominal 3 MV across the switch. The fields in the triggered gap are about 275 kV/cm and the untriggered gap fields range from 265 to 295 kV/cm. This results in about 1/3 of the total voltage being applied across the triggered gap.

The trigger consists of a 1/8 inch diameter Elkonite pin positioned within a .440 inch diameter hole in the anode of the trigger gap. The pin tip is rounded and positioned nominally flush with the

Report Documentation Page

Form Approved
OMB No. 0704-0188

Public reporting burden for the collection of information is estimated to average 1 hour per response, including the time for reviewing instructions, searching existing data sources, gathering and maintaining the data needed, and completing and reviewing the collection of information. Send comments regarding this burden estimate or any other aspect of this collection of information, including suggestions for reducing this burden, to Washington Headquarters Services, Directorate for Information Operations and Reports, 1215 Jefferson Davis Highway, Suite 1204, Arlington VA 22202-4302. Respondents should be aware that notwithstanding any other provision of law, no person shall be subject to a penalty for failing to comply with a collection of information if it does not display a currently valid OMB control number.

1. REPORT DATE JUN 1985	2. REPORT TYPE N/A	3. DATES COVERED -			
4. TITLE AND SUBTITLE Cascade Switch Implementation On PBFA I		5a. CONTRACT NUMBER			
		5b. GRANT NUMBER			
		5c. PROGRAM ELEMENT NUMBER			
6. AUTHOR(S)		5d. PROJECT NUMBER			
		5e. TASK NUMBER			
		5f. WORK UNIT NUMBER			
7. PERFORMING ORGANIZATION NAME(S) AND ADDRESS(ES) Sandia National Laboratories Albuquerque, New Mexico		8. PERFORMING ORGANIZATION REPORT NUMBER			
9. SPONSORING/MONITORING AGENCY NAME(S) AND ADDRESS(ES)		10. SPONSOR/MONITOR'S ACRONYM(S)			
		11. SPONSOR/MONITOR'S REPORT NUMBER(S)			
12. DISTRIBUTION/AVAILABILITY STATEMENT Approved for public release, distribution unlimited					
13. SUPPLEMENTARY NOTES See also ADM002371. 2013 IEEE Pulsed Power Conference, Digest of Technical Papers 1976-2013, and Abstracts of the 2013 IEEE International Conference on Plasma Science. Held in San Francisco, CA on 16-21 June 2013. U.S. Government or Federal Purpose Rights License					
14. ABSTRACT The triggered gas switches in PBFA I were recently changed from a single gap trigatron design to a 15-stage cascade design with a relatively short triggered gap. This improved design provides a low jitter value and has an extremely low probability of prefire. The triggered section represents about onethird of the total voltage of the switch and is triggered with a pin configuration similar to the previous trigatron design. The fields in the triggered gap were adjusted to allow prompt triggering and yet avoid prefires in the trigger gap at the operating gas pressure. Operating parameters of the switch will be discussed along with an analysis of the improved machine performance with respect to jitter, prefire probability, and operating voltage.					
15. SUBJECT TERMS					
16. SECURITY CLASSIFICATION OF:			17. LIMITATION OF ABSTRACT SAR	18. NUMBER OF PAGES 4	19a. NAME OF RESPONSIBLE PERSON
a. REPORT unclassified	b. ABSTRACT unclassified	c. THIS PAGE unclassified			

surface of the anode. The hardware within the trigger pin assembly consists of the pin and associated positioning hardware along with two insulators to accurately position the pin within the anode and form the gas seal.

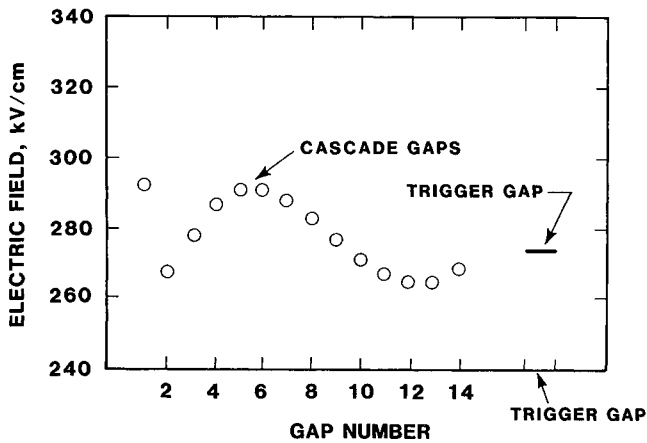

Figure 3. Electric fields in the gaps along the centerline of the cascade switch.

The switch is controlled by applying a 140 kV pulse (doubling of a 70 kV pulse on reflection from the open circuit) on the trigger pin. This initiates streamer propagation toward the cathode of the trigger section and toward the edges of the hole in the anode. Experimental evidence suggests that the field strength in the main gap acts to enhance the propagation of a light positive streamer toward the trigger gap anode which is followed by a restrike from the cathode. This causes an arc to form across the trigger gap before the arc forms between the pin and surrounding hole. Our understanding of streamer propagation in gases is discussed in more detail in Ref. 1. This phenomenology dictates a careful optimization of the fields in the region of the trigger pin as well as the voltage applied to the pin. These parameters were optimized for this particular switch design through a series of tests in which parameters were adjusted independently. After the switches were constructed, the gaps in the cascade section were found to be significantly smaller than the design spacing. This led to an unacceptably high jitter in the triggered mode because the field in the trigger section was too low in relation to that in the cascade section of the switch. We successfully restored the low jitter performance by decreasing the trigger gap by 0.315 inches.

After the triggered gap breaks down, the remaining gaps are overstressed in sequence from the anode toward the cathode. As each successive gap closes, a voltage wave travels out radially along the disk, into the water, and on to the next gap. This sequential overstressing of the cascade gaps causes these gaps to break down in a multichannel mode with a minimum of series inductance and resistance. The multichannel arcing in the cascade gaps also prolongs electrode life by minimizing the erosion. After more than a hundred shots, the electrodes were not significantly damaged and are still in use without reconditioning.

Performance

The primary design goals for the cascade switch were low inductance, well behaved self break characteristics, low jitter when triggered, and high reliability. The low inductance of about 70 nH as

compared with about 150 nH for the trigatron derives mainly from the multichanneling, which occurs in all but the triggered gap. The reliability has been demonstrated in over a year of operation with very low maintenance requirements. The self-break characteristics, which are manifested in operation as prefire probability, and jitter will be discussed in more detail.

The self-break characteristics of the cascade switch are illustrated in Fig. 4 in which the self-break voltage is plotted as a function of gas pressure. In these tests, the applied voltage history is described by:

$$V(t) = V_p \left\{ 1 - \cos \left(\frac{\pi t}{2\tau} \right) \right\}$$

where $\tau = 820$ ns and

$V_p =$ Peak Intermediate Store Voltage.

The peak voltage is adjusted as the gas pressure is changed to provide the same time to breakdown throughout the series of tests. Each switch has a rather well-defined, self-break voltage for a given gas pressure, but there are significant differences between nominally identical switches. Each switch exhibits a range of about 250 kV in self-break voltage at a given gas pressure, but an ensemble of only six randomly selected switches had a typical range of about 400 kV at 40 psia and as much as 600 kV above 60 psia. Of primary importance operationally, is the behavior of the entire 36-line ensemble of switches. The machine must be operated at a gas pressure that will ensure a very low probability of breakdown in an untriggered mode. Even with the apparently large spread in self-break voltages among the 36 switches, the probability of untriggered closure has proven to be very low with an appropriate choice of operating pressure. A nominal gas pressure of 56 PSIA was chosen for a peak intermediate store voltage of 2.6 MV. We observed only four premature switch closures in a year of operation and more than 100 shots. In each of these cases the switches closed within 30 ns of the nominal triggered closure time.

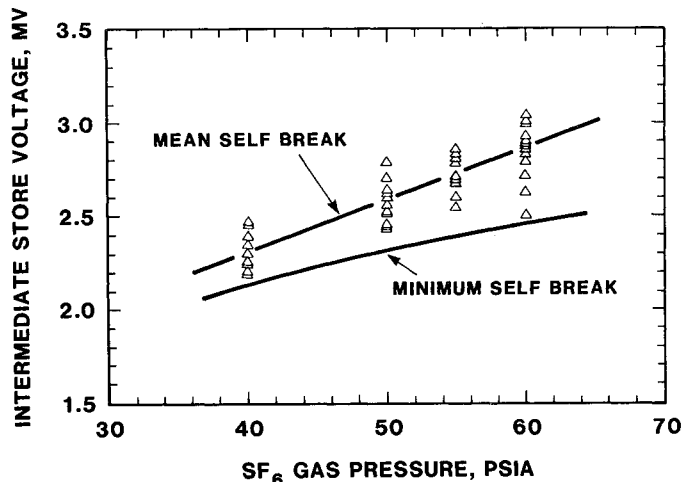

Figure 4. Results of self break tests in which 6 units were overstressed to self-break at several different gas pressures. The Marx charge was adjusted in all but the 60 psia shots to provide a nearly constant time to breakdown.

Histograms of switch closure times for both the trigatron and the cascade switches are shown in Fig. 5 for comparison. This data, selected from four shots for both the trigatron and the cascade switch, was corrected to give the same mean closure time with an arbitrary choice of time zero. The distribution of switch closure time is nearly normal in both cases with a standard deviation of about 2.5 ns. The most important improvement in triggered behavior is the total avoidance of the premature closures occurring more than 30 ns before the mean. This has a profound effect on the power flow performance of PBFA I in the vacuum convolute region where each of the 36 lines are connected in parallel. A single line coming more than 10 ns early can cause severe losses or even arcing in the feed because of the disturbance to the magnetic insulation.

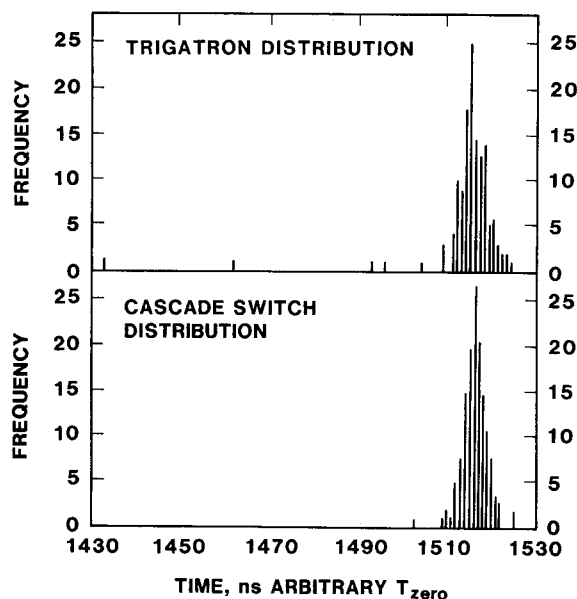

Figure 5. Histograms of gas switch closure times for the trigatron and cascade switch in the upper and lower plots respectively. These times are plotted with respect to an arbitrary zero of time in the firing countdown sequence.

In an attempt to further decrease the switch jitter, we recently conducted a series of experiments in which a faster rising pulse was used to trigger the cascade switch. The PBFA I trigger system provides a pulse that rises to about 70 kV with a rate of about 1kV/ns. For these experiments, a Physics International TG 125 pulser was modified to provide 6 outputs with a rise of about 2.5 kV/ns to 70 kV. We measured the response time of the switch from the arrival time of the trigger pulse at the switch to the beginning of current flow through the switch. Experiments were conducted at several pressures with six switches and between 15 and 20 shots per pressure setting. The observed standard deviation in the response time is plotted for each switch in Fig. 6 as a function of gas pressure. For comparison, we also plot the observed standard deviation for shots using the standard trigger system as a control experiment.

Several conclusions can be drawn from these observations. First, the distribution of response times with the faster rising trigger pulse exhibits a lower average variance indicating a better triggered response. There is also an indication at 60 psia that

the differences between switches tends to be minimized when the faster trigger pulse is applied.

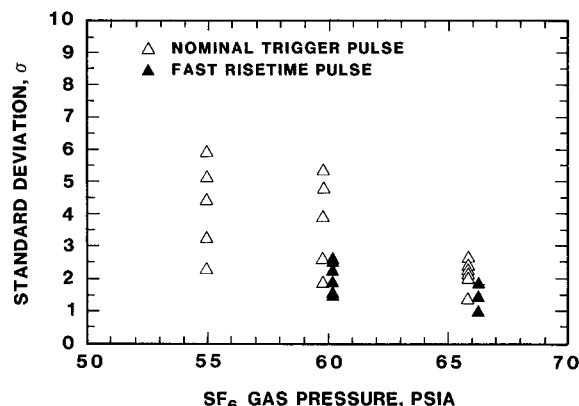

Figure 6. Results of experiments with a faster rising trigger pulse. The standard deviation in the response time of several different switches is plotted as a function of gas pressure. The open and filled symbols represent data taken with the standard trigger pulse with a 1 kV/ns rise, and the enhanced rise pulse with a 2.5 kV/ns rise respectively.

As an unexpected result, the jitter seems to improve for the standard trigger system as the operating pressure is increased. This is an example of the delicate way in which the component characteristics of a multimodule machine interact. In our original optimization of the gas switch pressure, the Marx generator erection time spread was typically greater than 60 ns in the 36 modules. This resulted in a rather wide spread of voltages on the gas switch at the time we applied the trigger pulse. Under these conditions, the gas pressure could not be raised above about 55 psia without running a significant risk that the low voltage switches would be untriggered. In the past few months, the typical Marx spread has been reduced to about 20 ns, providing a nearly uniform voltage on the entire ensemble of gas switches when the trigger pulse is applied. With the improved performance of the Marx generators, we are able to operate at a higher gas pressure in the cascade switches and have demonstrated a first-to-last spread of less than 10 ns for all 36 modules.

Summary

PBFA I gas switching has been upgraded from the single gap trigatron design to a 15-stage cascade design consisting of a trigger section and 14 stages which self break in a cascade sequence. As a result of implementing the cascade switch design on PBFA I the first to last spread between modules has decreased from a typical value of 100 ns to about 15 ns. This improvement has dramatically improved the power flow and diode performance by minimizing the feed breakdowns associated with early or late lines. Our recent experiments with a faster rising trigger pulse indicate that with the recently improved Marx erection simultaneity, and an improved trigger system, the asynchrony may be further reduced to 10 ns or less.

Acknowledgements

The authors would like to acknowledge the research and development efforts of E. L. Neau, W. B. Moore, J. F. Seamen, and S. R. Babcock whereby the cascade switch design was developed. Many development tests on similar designs were conducted on single line pulse power machines like RIPPLE, MITE and HYDRAMITE.

References

1. Martin, T. H., "A Model That Predicts Pulse Charged Gas Switching Breakdown Phenomena", to be presented at the 5th IEEE Pulsed Power Conference, Arlington, VA, June 10-12, 1985.
2. L. X Schneider, "Engineering Low-Jitter Marx Generators," to be presented at the 5th IEEE Pulsed Power Conference, Arlington, VA, June 10-12, 1985.