

AUTOMATED MAGNET TESTING FACILITY\*

K. T. Lancaster and A. W. Sharpe  
 Sandia National Laboratories  
 Albuquerque, NM 87185

Abstract

The automated Magnet Testing Facility (MTF) is a computer controlled, 60 kJ, parallel capacitor bank that was constructed to pulse test solenoidal magnets. Coil sets from different vendors were evaluated on two criteria: uniformity of field and coil reliability. The first criterion, uniformity of field, is evaluated by installing a pair of coils into stainless steel housings and pulse mapping the fields at a low energy level. Forty field-strength samples were easily collected with the one button operation of the MTF. Two thousand high field pulse tests, at a 20 kG level, is the second criterion for magnet acceptance. In a manually operated system a single operator can achieve this goal in six months. In a continuous operating mode, MTF can achieve the same goal in 42 days.

Introduction

The linear electron beam accelerators at Sandia National Laboratories use solenoidal coils to guide the electron beam through the beam tube. A facility was needed to test and evaluate magnet coils that were supplied by prospective vendors. The results of these tests were needed to select the coils to be used in a new accelerator at Sandia. The time available to test the coils was limited. Therefore, an automated magnet testing facility was constructed. This paper addresses the MTF and how it expedited the magnet evaluation process.

Sub-Systems

The energy supplied to the coils is stored in a parallel capacitor bank. The energy stored at a 20 kV charge in this portable bank can be varied from 4-60 kJ by disconnecting the copper swing-away straps from the individual capacitors. The charging voltage can also be varied to match the specific energy requirement for a set of coils. The charging rate can be tailored by varying the current from 10 to 100 mA. These parameters make this a useful and flexible bank for the MTF.

The output of the capacitor bank is controlled by an ignitron firing circuit. A relay closure actuated either by the programmable controller or the operator sends a 30 volt trigger signal to a 30:1 trigger transformer. This 900 volt signal energizes the grid of a 5 kv krytron tube. The 5 kv signal, that is shorted through the krytron to ground, is also coupled through a capacitor and coaxial cable isolation transformer to the trigger pin of the ignitron which is the main switch for the parallel capacitor bank. The trigger circuit diagram is shown in Figure 1.

The system controller is a Gould micro 84 programmable controller (PC). This device is a low cost, intelligent relay box. The MTF control-system interface voltages are 120 V a.c. and 24 V a.c. Therefore, an input and output module were purchased for each voltage level. These modules plug onto the controller to form a tight, solid, integrated unit. The inputs and outputs are optically isolated from the computer bus to guard against voltage transients. Also, the case is shielded from electromagnetic interference (EMI) and radio-frequency interference

(RFI) to enable the controller to survive in an adverse environment.

**TRIGGER CIRCUIT**

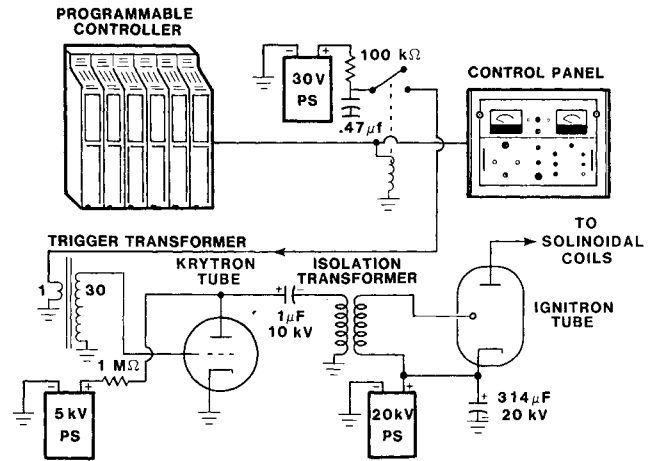

Figure 1. Trigger Circuit Diagram

The controller uses ladder logic programming-language, shown in Figure 2, to manipulate its outputs according to the active program. Ladder logic is particularly useful in visualizing the power flow to individual latches. Timers, counters, and drum sequencers are some of the programming blocks available in the PC. The limiting factor of a micro 84 is the programming memory available. However, for the task of automating a parallel capacitor bank, this PC is ideal.

**LADDER LOGIC DIAGRAM**

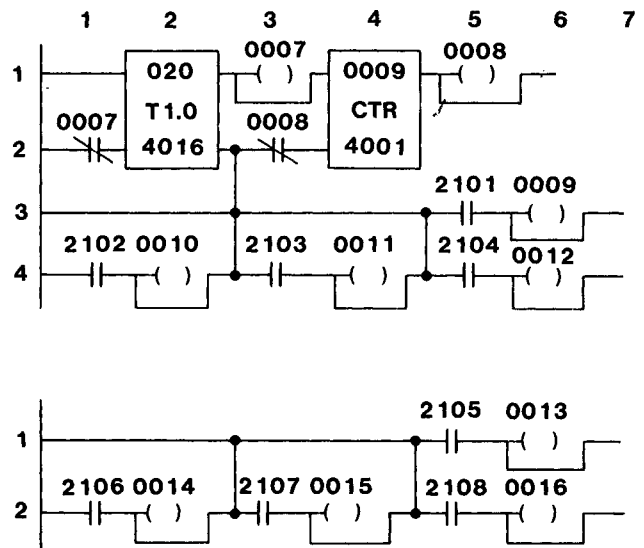

Figure 2. Ladder Logic Diagram

\*This work was supported by the U. S. Department of Energy under Contract No. DE-AC04-76DP00789.

## Report Documentation Page

*Form Approved*  
*OMB No. 0704-0188*

Public reporting burden for the collection of information is estimated to average 1 hour per response, including the time for reviewing instructions, searching existing data sources, gathering and maintaining the data needed, and completing and reviewing the collection of information. Send comments regarding this burden estimate or any other aspect of this collection of information, including suggestions for reducing this burden, to Washington Headquarters Services, Directorate for Information Operations and Reports, 1215 Jefferson Davis Highway, Suite 1204, Arlington VA 22202-4302. Respondents should be aware that notwithstanding any other provision of law, no person shall be subject to a penalty for failing to comply with a collection of information if it does not display a currently valid OMB control number.

1. REPORT DATE <b>JUN 1985</b>	2. REPORT TYPE <b>N/A</b>	3. DATES COVERED <b>-</b>	
4. TITLE AND SUBTITLE <b>Automated Magnet Testing Facility</b>		5a. CONTRACT NUMBER	
		5b. GRANT NUMBER	
		5c. PROGRAM ELEMENT NUMBER	
6. AUTHOR(S)		5d. PROJECT NUMBER	
		5e. TASK NUMBER	
		5f. WORK UNIT NUMBER	
7. PERFORMING ORGANIZATION NAME(S) AND ADDRESS(ES) <b>Sandia National Laboratories Albuquerque, NM 87185</b>		8. PERFORMING ORGANIZATION REPORT NUMBER	
9. SPONSORING/MONITORING AGENCY NAME(S) AND ADDRESS(ES)		10. SPONSOR/MONITOR'S ACRONYM(S)	
		11. SPONSOR/MONITOR'S REPORT NUMBER(S)	
12. DISTRIBUTION/AVAILABILITY STATEMENT <b>Approved for public release, distribution unlimited</b>			
13. SUPPLEMENTARY NOTES <b>See also ADM002371. 2013 IEEE Pulsed Power Conference, Digest of Technical Papers 1976-2013, and Abstracts of the 2013 IEEE International Conference on Plasma Science. Held in San Francisco, CA on 16-21 June 2013. U.S. Government or Federal Purpose Rights License.</b>			
14. ABSTRACT <b>The automated Magnet Testing Facility (MTF) is a computer controlled, 60 kJ, parallel capacitor bank that was constructed to pulse test solenoidal magnets. Coil sets from different vendors were evaluated on two criteria: uniformity of field and coil reliability. The first criterion, uniformity of field, is evaluated by installing a pair of coils into stainless steel housings and pulse mapping the fields at a low energy level. Forty field-strength samples were easily collected with the one button operation of the MTF. Two thousand high field pulse tests, at a 20 kG level, is the second criterion for magnet acceptance. In a manually operated system a single operator can achieve this goal in six months. In a continuous operating mode, MTF can achieve the same goal in 42 days.</b>			
15. SUBJECT TERMS			
16. SECURITY CLASSIFICATION OF:			17. LIMITATION OF ABSTRACT
a. REPORT <b>unclassified</b>	b. ABSTRACT <b>unclassified</b>	c. THIS PAGE <b>unclassified</b>	<b>SAR</b>
			18. NUMBER OF PAGES <b>3</b>
			19a. NAME OF RESPONSIBLE PERSON

The power supply used in MTF is a 20 kV, 100 mA dc supply. The voltage and current controls on the power supply are set manually using ten turn potentiometers. The control panel has 24 V ac wired into all the switches, lights, and relays. The PC power supply controlling outputs are wired, in parallel with the normally open switches and in series with the normally closed switches, to allow either automatic or manual operation. The controller then reads all the status lights and relay positions to determine if the proper actions have been taken when compared to the commands given.

There was a need for EMI and RFI protection of the solid state power supplies and magnetic field detection circuitry. A double shielded screen box with  $\pi$  filters and transient absorbers to provide the PC access to the system's 30 control and feedback channels is used to solve this problem. A drawing of the filter panel is shown in Figure 3.

### FILTER PANEL (10 CHANNELS)

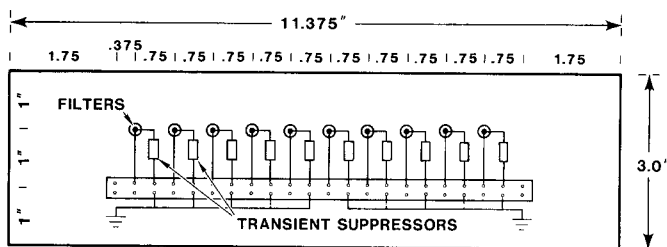

Figure 3. Filter Panel Picture

An automatic control system is only as dependable as its feedback system. The feedback system for MTF consists of three branches: sensors on the coils, relay information from the power supply, and safety information from the interlock system. The sensors on the coils are temperature sensing snap disks and field strength B-dot probes. The snap disks halt the timing function if the magnets get too warm while the B-dot probes, inside the coil bore, transmit a magnetic field strength signal back to a latching detection circuit. The latching section of the circuit activates a solid state relay, which then transmits to the PC that an acceptable field strength has been detected. The relay information from the power supply is a series of 24 V ac signals. These signals are read in and assigned to ladder logical elements used in determining if the actions taken were the correct response to the PC commands. The safety interlock is the third branch of the feedback network. A safety barrier with a continuity check is used to determine if someone has entered the high voltage area. When this circuit is interrupted, the system will automatically turn off the power supply, dump the bank energy into a resistive load, and halt the timing process until reset by an operator.

#### Field Mapping

Low voltage field mapping was required to extract the uniformity of field data. A one-minute automatic cycle mode of the testing facility was used to assist in collecting this data. The maximum voltage of the bank was adjusted to 4 kV and the charge rate was 40 mA. The integrated signal from a calibrated B-dot probe was recorded on oscilloscope camera film. The field-mapping, data-collection process for a pair of coils took less than one hour.

#### High Field Pulse Testing

Endurance testing is the primary task of the magnet testing facility. The counter inside the PC records these shots while the feedback system constantly monitors the status of all the vital functions in the system. With the automatic cycle time set for thirty minutes, the voltage adjusted for 16.5 kV, and the charge rate fixed at 40 mA, the system recorded 2312 high voltage shots on a successful set of coils in 2.5 months. The testing time frame was extended by a three week trial period. During this period the system couldn't operate without supervision, and the feedback network was being upgraded.

#### Verification of Feedback System

High voltage shot number 213 on an unsuccessful set of magnets caused a turn-to-turn failure in the north coil. The coil exploded inside the stainless steel casing, which wedged it in the housing. The south magnetic field detection circuit indicated that the south magnet was operating properly. However, the north circuit indicated a weak field strength, which caused the PC to stop cycling. The failure occurred after normal working hours and if the failure had gone undetected, the system would have pulsed the damaged coil for several hours, damaging the facility severely. A sketch of the failed coil is shown in Figure 4.

### EXPLODING MAGNET

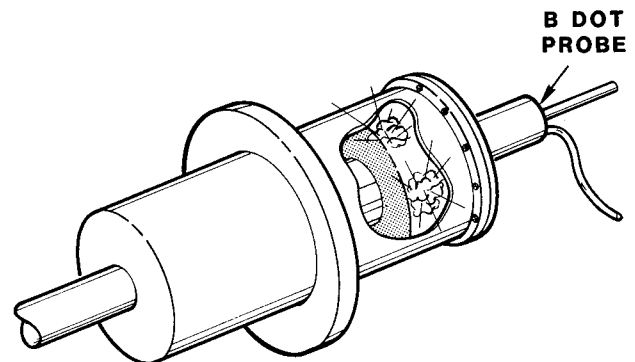
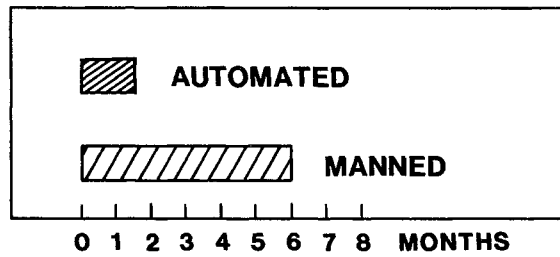

Figure 4. Exploded Magnet Picture

#### Time Savings

The high energy coils supplied to MTF were designed for a single-shot application. Therefore, the repetition rate, which is restricted by thermal dissipation, is two shots per hour. To achieve the two thousand shot endurance criterion, a single operator would test these coils for 125 working days. This represents a six-month testing period. Conversely, the automated system can achieve the same results in 42 days: a time savings of four- and one-half months. The automated system's cost is small compared to the cost of an operator for six months. A graphical representation of time savings using an automated versus manned facility is shown in Figure 5.

## TIME TO TEST



- 1. MANNED MAGNET TESTING FACILITY  
FOR  
2000 SHOTS AT 1 SHOT/30 min = 140 days  
8 hour day**
  - 2. AUTOMATED MAGNET TESTING FACILITY  
FOR  
2000 SHOTS AT 1 SHOT/30 min = 42 days  
continuous**
- SAVE 98 days**

Figure 5. Time to Test

### Conclusion

The objective of the magnet testing facility was to evaluate vendor-supplied sets of solenoidal coils. This was done by low power pulse mapping and by high power endurance testing the coils. The automatic features of the magnet testing facility were helpful in low power pulse mapping, but they were critical in high power endurance testing. The programmable controller and associated feedback systems are reliable in a high field environment. This was apparent on shot #213 when a low field condition was detected on the north magnet, and the system was interrupted to prevent further damage. This system is dependable, and the savings in time and manpower clearly justified the implementation of an automated testing facility for the beam guiding magnets.