

Adaptation of ASTERIX to Positive Polarity for 2 to 4-MV Rod-Pinch Diode Experiments and Diode Electrical Analysis*

R. J. Allen^ξ, J. R. Boller⁺, R. J. Commisso, F. C. Young⁺

Plasma Physics Division, Naval Research Laboratory, Washington, DC 20375

F. Bayol, P. Charre, A. Garrigues

Centre d'Etudes de Gramat, Gramat, France

Abstract

ASTERIX is a high-voltage (6 to 7 MV), $\sim 60\text{-}\Omega$, $\sim 50\text{-ns}$ FWHM pulse generator located at the Centre d'Etudes de Gramat (CEG) in Gramat, France. It has been recently used for the first evaluation of the rod-pinch[1] electron-beam diode as a source for high-resolution, penetrating flash radiography at up to 4 MV (on a 40 to 50- Ω load).[2] For this evaluation, the generator was operated in positive polarity, i.e., with positive high voltage applied to the inner coaxial electrode. This had never been done before on ASTERIX. Also, it was necessary to eliminate pre-pulse with a vacuum pre-pulse switch to achieve the desired diode behavior. To evaluate the diode physics, the current and voltage at the diode load must be determined. The electrical length of the vacuum section, the front-end architecture, and the design of the voltage probe located on the oil side of the vacuum/oil interface present difficulties in determining an equivalent circuit for inferring the load-voltage time history.

In this paper, the modifications made to the ASTERIX generator for this rod-pinch evaluation will be discussed. The limitations encountered will be reviewed and ideas for improvement will be suggested. Also, the design of the rod-pinch hardware will be presented. We will describe the approach taken to determine the load voltage time history. The effects of the pre-pulse on the diode behavior and the performance of the pre-pulse switch will also be presented.

I. CONVERTING ASTERIX TO POSITIVE POLARITY FOR ROD-PINCH LOAD

The main components of ASTERIX are a 64-stage (100 kV per stage) Marx bank, a 35- Ω oil blumlein with an oil-breakdown main switch, a coaxial section with a series oil breakdown pre-pulse switch, a stacked-ring insulator separating oil from vacuum, and a 114- Ω vacuum coaxial output section, which normally terminates at a bremsstrahlung diode load. The main hardware issues with operating ASTERIX in positive polarity concern the stacked ring insulator, the Marx charging voltage, the

main switch gap, and the addition of a vacuum pre-pulse switch. The vacuum faces of the stacked ring insulators are beveled at 45 degrees to increase breakdown strength. For positive polarity, a new insulator was made from spare parts with the insulators reversed to provide greater breakdown strength.

A. Simulation of Rod-Pinch Load on ASTERIX

Because ASTERIX was designed for negative polarity, the maximum charging voltage of the Marx in positive polarity was not known. The designer of the Marx suggested a limit of 70% of maximum or 70 kV. Circuit modeling of the rod-pinch diode on ASTERIX was performed in order to determine if a 4-MV output could be achieved with a 70% charge and nominal rod-pinch diode parameters. An existing PSPICE model of ASTERIX was converted into a BERTHA[3] transmission line model. This was done so that a BERTHA rod-pinch diode model could be utilized and the entire system simulated with load voltages of 2 and 4 MV and anode rod diameters of 0.5, 1.0 and 2.0 mm. Because the rod-pinch diode is known to operate well in the range of 20 to 40 Ω , the cathode radius was adjusted for 30 Ω at the peak of the radiation output (estimated as being proportional to the diode current times diode voltage squared). Simulations indicated two problems. First, it was not possible to reach 4 MV on the diode when the diode was designed for the nominal 30- Ω impedance and with the Marx charged to 70 kV. However, it was possible to achieve 4 MV with a diode designed for $\sim 35\text{ }\Omega$ and a 70-kV Marx charge. In the experiment, ASTERIX did not operate as efficiently as the model suggested due to the main switch gap (described later). To achieve 4 MV on the load it was necessary to operate at a 75-kV Marx charge and with impedances from 40 to 50 Ω .

The second problem concerned the pre-pulse. With 4 MV on the diode, a positive pre-pulse of 365-kV peak, $>100\text{-ns}$ FWHM was predicted. The peak occurred about 250 ns before the main pulse and generated an electric field on the cathode four times greater than the 100 kV/cm normally required to initiate plasma formation on the cathode surface. Because of plasma expansion from

* Work supported by CEG and SNL.

^ξ email: allen@suzie.nrl.navy.mil

⁺ JAYCOR, McLean, VA 22102

Report Documentation Page

Form Approved
OMB No. 0704-0188

Public reporting burden for the collection of information is estimated to average 1 hour per response, including the time for reviewing instructions, searching existing data sources, gathering and maintaining the data needed, and completing and reviewing the collection of information. Send comments regarding this burden estimate or any other aspect of this collection of information, including suggestions for reducing this burden, to Washington Headquarters Services, Directorate for Information Operations and Reports, 1215 Jefferson Davis Highway, Suite 1204, Arlington VA 22202-4302. Respondents should be aware that notwithstanding any other provision of law, no person shall be subject to a penalty for failing to comply with a collection of information if it does not display a currently valid OMB control number.

1. REPORT DATE

JUN 2001

2. REPORT TYPE

N/A

3. DATES COVERED

-

4. TITLE AND SUBTITLE

Adaptation of ASTERIX to Positive Polarity for 2 to 4-MV Rod-Pinch Diode Experiments and Diode Electrical Analysis

5a. CONTRACT NUMBER

5b. GRANT NUMBER

5c. PROGRAM ELEMENT NUMBER

6. AUTHOR(S)

5d. PROJECT NUMBER

5e. TASK NUMBER

5f. WORK UNIT NUMBER

7. PERFORMING ORGANIZATION NAME(S) AND ADDRESS(ES)

Plasma Physics Division, Naval Research Laboratory, Washington, DC 20375

8. PERFORMING ORGANIZATION REPORT NUMBER

9. SPONSORING/MONITORING AGENCY NAME(S) AND ADDRESS(ES)

10. SPONSOR/MONITOR'S ACRONYM(S)

11. SPONSOR/MONITOR'S REPORT NUMBER(S)

12. DISTRIBUTION/AVAILABILITY STATEMENT

Approved for public release, distribution unlimited

13. SUPPLEMENTARY NOTES

See also ADM002371. 2013 IEEE Pulsed Power Conference, Digest of Technical Papers 1976-2013, and Abstracts of the 2013 IEEE International Conference on Plasma Science. IEEE International Pulsed Power Conference (19th). Held in San Francisco, CA on 16-21 June 2013. U.S. Government or Federal Purpose Rights License.

14. ABSTRACT

ASTERIX is a high-voltage (6 to 7 MV), ~ 60- μ s, ~ 50- ns FWHM pulse generator located at the Centre d'Etudes de Gramat (CEG) in Gramat, France. It has been recently used for the first evaluation of the rod-pinch[1] electronbeam diode as a source for high-resolution, penetrating flash radiography at up to 4 MV (on a 40 to 50- μ s load).[2] For this evaluation, the generator was operated in positive polarity, i.e., with positive high voltage applied to the inner coaxial electrode. This had never been done before on ASTERIX. Also, it was necessary to eliminate pre-pulse with a vacuum pre-pulse switch to achieve the desired diode behavior. To evaluate the diode physics, the current and voltage at the diode load must be determined. The electrical length of the vacuum section, the front-end architecture, and the design of the voltage probe located on the oil side of the vacuum/oil interface present difficulties in determining an equivalent circuit for inferring the load-voltage time history. In this paper, the modifications made to the ASTERIX generator for this rod-pinch evaluation will be discussed. The limitations encountered will be reviewed and ideas for improvement will be suggested. Also, the design of the rod-pinch hardware will be presented. We will describe the approach taken to determine the load voltage time history. The effects of the pre-pulse on the diode behavior and the performance of the pre-pulse switch will also be presented.

15. SUBJECT TERMS

16. SECURITY CLASSIFICATION OF:			17. LIMITATION OF ABSTRACT SAR	18. NUMBER OF PAGES 4	19a. NAME OF RESPONSIBLE PERSON
a. REPORT unclassified	b. ABSTRACT unclassified	c. THIS PAGE unclassified			

Standard Form 298 (Rev. 8-98)
Prescribed by ANSI Std Z39-18

the anode and cathode surfaces, the diode model predicted that the diode was essentially short circuited before the main pulse arrived. To fix this problem, a vacuum pre-pulse switch, which had been previously used on ASTERIX in another experiment, was installed. This switch was a 210-mm long, 130-mm diameter cylinder of high-density polyethylene that operated by surface flashover. It was inserted into the 150-mm diameter center conductor of the 114- Ω coaxial section at the output of the machine. The metal edges at either end of the plastic had a 1-mm radius.

B. Location of the Vacuum Pre-pulse Switch

Field analysis was required to determine the best axial position for the pre-pulse switch. If the switch was placed too far forward, pre-pulse could couple through the capacitance of the switch and would not be reduced enough. If the switch were placed too far backward, the stacked ring insulators would be exposed to UV from the flashover, possibly resulting in breakdown of the stacked ring insulator. Using 2D electrostatic field analysis, a capacitive division of about a factor of six was found when the front edge of the pre-pulse switch was located 320 mm from the door of the machine, reducing the pre-pulse to an acceptable level.

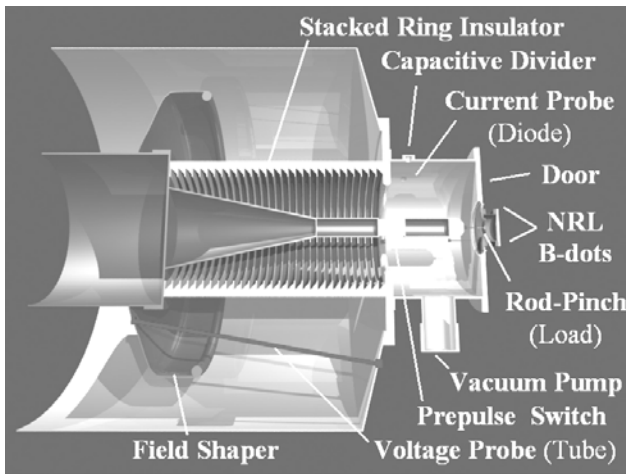

Figure 1. Diagram of ASTERIX front-end showing the locations of the tube voltage probe, diode current probe, rod-pinch load, and the pre-pulse switch.

In the experiments, the pre-pulse switch was placed even further from the door, as shown in Fig. 1, and its effectiveness was clearly demonstrated on the first two shots. The machine and diode parameters for shots #6382 and #6383 were identical except for the installation of the pre-pulse switch on the second shot. On shot #6382 the current oscillated between +500 and -1000 A starting about 500 ns before the main pulse. The diode impedance

was near zero at the start of the main pulse and only increased to a peak of about 20 Ω during the pulse. This behavior was consistent with a plasma-filled diode, the result of the pre-pulse current. In sharp contrast, the pre-pulse current on shot #6383 remained near zero prior to the main pulse. The calculated diode impedance showed the expected behavior of high impedance at the beginning of the main pulse and then a gradual decrease to a value of 30 to 40 Ω at the peak of the radiation signal. The benefit of pre-pulse suppression was clearly seen in the radiation measurements, which gave a dose of 2 rad(Si) at one meter for shot #6382 and 6.9 rad(Si) for shot #6383. The vacuum pre-pulse switch was used on all subsequent shots.

C. Diode Hardware

The diode hardware for the rod-pinch load was designed around several constraints. The basic rod-pinch diode is a thin anode rod that is inserted through a small hole in a thin disk cathode. In these experiments the cathodes were 38.1-mm outer diameter, 3.2-mm thick graphite disks with centered through holes. The anodes were tungsten rods with diameters of 0.5, 1.0, or 2.0 mm. The anodes had a 10-mm tapered tip, which extended 16 to 24 mm beyond the cathode. One constraint in designing the hardware for this rod-pinch diode was that the tip of the rod had to be beyond the ASTERIX end plate so that the x-ray diagnostics would have as little material between them and the rod tip as possible. In order to maintain vacuum, a “can” was designed that created a vacuum cylinder around the anode tip as shown in Fig.2. The end plate of this can was made of 17.5-mm thick Plexiglas so that visual inspection of the anode-cathode alignment could be made. A 5-mm thick disposable piece of Plexiglas was inserted behind this plate of avoid damage.

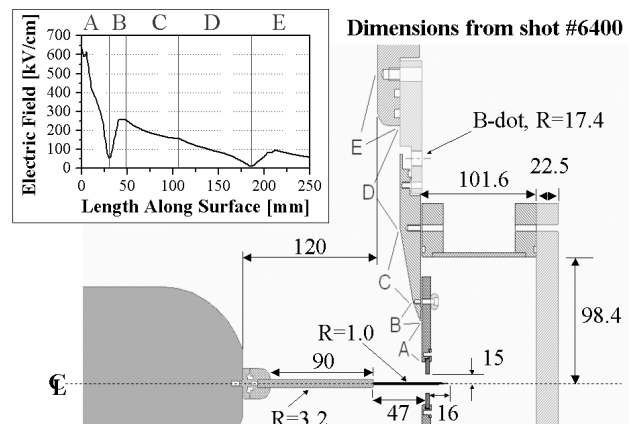

Figure 2. Drawing of the rod-pinch diode hardware on ASTERIX (all dimensions in mm) and the calculated electric field along the stressed surface.

[1] S.B. Swanekamp

[2] Fred

[3] Bertha

II. ELECTRICAL ANALYSIS OF THE ROD-PINCH DIODE ON ASTERIX

The metal hardware that connects the cathode to the door of ASTERIX was carefully designed. The “shield” was the most complex component. The shield connected the existing door of ASTERIX to the cathode holder, an aluminum disk that clamps the graphite cathode. Because of misalignment of the anode with the axis of the vacuum chamber due to the cantilever of the anode stack, the shield was designed to allow the cathode holder up to 10 mm of radial motion while maintaining a good current contact after being bolted down. The shield also housed four B-dot current probes. The shield split into two pieces at the B-dot location so that one piece attached to the ASTERIX door, while the other piece formed a covered recess for the B-dot probes, held the cathode holder, and supported the external can. The back surface of the shield had two angled surfaces designed to minimize the electric field. Electrostatic field analysis was used to calculate the electric field on the shield surface (shown in Fig. 2). With 4 MV applied to the anode, the design of the shield was such that it kept the electric field on the shield surface under 300 kV/cm. In addition, the shield was anodized and coated with a special four-part oil mixture. Note that the anode-door spacing, shown as 120 mm in Fig.2, was set to 60 mm on most of the lower voltage shots. In the experiment, no pitting or other evidence of breakdown from this surface was observed.

Because the hardware near the rod-pinch load was made of aluminum, carbon or Plexiglas, limited nuclear activation of short-lived radioactivity in the hardware from ion bombardment was possible. No evidence of residual activation of the hardware was observed in surveys after a shot.

D. Main Switch Optimization

The output voltage of ASTERIX in positive polarity was less than expected and the discrepancy was traced to the main switch. The main switch is an oil breakdown switch comprised of two spherical surfaces of differing radii separated by a gap of oil. Electrostatic field analysis indicated that the switch is symmetric for negative polarity, so that near full voltage both electrode surfaces are at the same percent of the JCM breakdown criterion. In this condition the gap is minimized and the resistance and inductance of the switch are minimized resulting in optimal machine performance. In positive polarity, however, the main switch is highly asymmetric with the positive electrode at a much higher percent of the JCM breakdown criterion. Therefore the electrode gap must be increased at a particular voltage. This change is believed to be the cause of the reduced ASTERIX output in positive polarity. A new design for the main switch has been studied that restores symmetry to the switch using an electrode reversal scheme. The new design was not implemented in these experiments, but may be applied in future work.

Two current probes measured the current, I_{Diode} , very near the load (see Fig.1) so that the load current, I_{Load} , was easily obtained. There were also four new B-dot probes at the load to verify this measurement. However, the long transit time between the location of the output voltage measurement, V_{Tube} , and the load made evaluation of the load voltage, V_{Load} , difficult. A simple inductive correction was initially used to determine the load voltage. With inductive correction, the load voltage, V_{Load} , was equated to V_{Tube} minus the front-end inductance, L , times the time derivative of I_{Load} . Short circuit shots were used to determine the value of L . On ASTERIX, however, there was a ~18-ns two-way transit time between the voltage measurement and the load. With a main pulse width of only ~50 ns, significant errors were introduced when inductive correction was applied. For a more accurate determination of V_{Load} , a new transmission line model was used.

In order to use transmission line analysis, a detailed transmission line model of the front end was created. A two-element line representing the section between I_{Diode} and the load was used with values determined simply by the coaxial geometry in this section. A seven-element transmission line model was used to represent the front-end section between the locations of the V_{Tube} and I_{Diode} measurements. Inductance values for these elements were determined from the geometry. The transit time for each element was determined by the trajectory of a wave through the front-end, which was estimated as the 50% potential line obtained from an electrostatic analysis. The impedance of each element was determined given the calculated inductance and transit time. The parameters of these seven elements were finely tuned using data from a short-circuit shot, where the voltage at the diode, V_{Diode} , could be measured by a capacitive monitor (pre-pulse switch not used). A better match to measurements was achieved when a shunt resistance was added between elements #6 and #7. Because it was believed that this resistance is the result of electron emission in the region represented by these elements, the resistance was given a $V^{3/2}$ voltage dependence in the analysis to represent a space-charge-limited current.

Analysis of the electrical data involved calculating V_{Diode} for the measured V_{Tube} and I_{Diode} using the seven-element transmission line model and then calculating V_{Load} and I_{Load} from V_{Diode} . The full nine-element transmission line model used for data analysis is shown in Fig. 3. Using BERTHA with the seven-element model, we injected the measured voltage waveform at the left end and the current waveform at the right end and output V_{Diode} . One caveat to using this technique is that the analysis must begin at the very beginning of the pulse where the measured current is near zero, otherwise significant error is introduced. After V_{Diode} was calculated, V_{Load} and I_{Load} were easily calculated using the two-element front-end model and a well-known

transmission line analysis technique. Note that the values used for the last two elements depend on the anode to

door separation, which was either 60 or 120 mm.

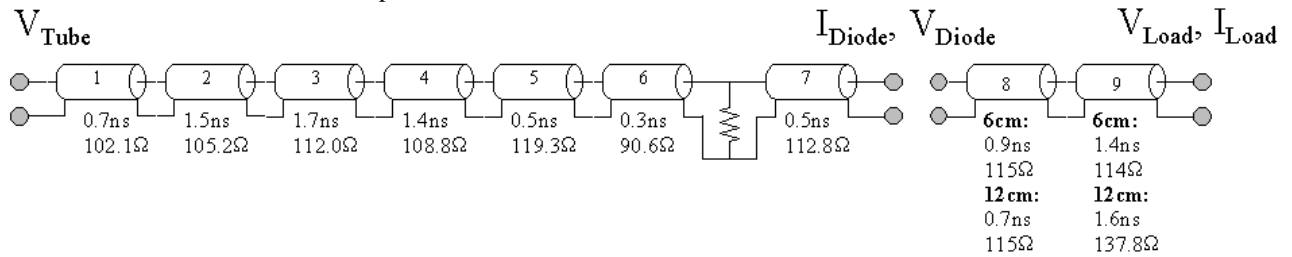

Figure 3. Transmission line model used to calculate load voltage and current (V_L , I_L) given the experimentally measured values of tube voltage (V_T) and diode current (I_D).

The load voltage waveforms were calculated for each shot using both inductive correction ($V_{\text{Corr.}}$) and transmission line (V_{Load}) techniques. The calculated I_{Load} waveforms were nearly identical to the measured I_{Diode} waveforms due to the short propagation time between these locations. While V_{Load} and $V_{\text{Corr.}}$ generally agreed near the peak of the pulse, there were significant differences. At the beginning of the pulse on most shots $V_{\text{Corr.}}$ was near zero or negative while I_{Load} was rising, which is a non-physical result. In contrast, V_{Load} was positive and credible. As another check on the results, the measured radiation signals were compared to the shapes of the waveforms calculated from I_{Load} times V_{Load} (or $V_{\text{Corr.}}$) raised to a power of between 1.5 and 2 (the exact exponent was uncertain). This comparison demonstrated that structure in the $V_{\text{Corr.}}$ waveform was unphysical. It was also observed for a few shots that the structure near the peak of waveforms calculated with $V_{\text{Corr.}}$ did not match the radiation signals. From these comparisons it was concluded that the transmission line calculation provided a more accurate determination of the load voltage, V_{Load} .

transmission line analysis for calculating the load voltage on ASTERIX was developed and shown to give more physically reasonable results than inductive correction.

Planned future work on ASTERIX includes modifications and optimizations to raise the output to the 6-MV level for rod-pinch experiments. The study of breakdown risks at critical points in oil and analysis of vacuum interface behavior at this positive voltage level (risk of electron emission from the grading rings and the iris) is ongoing at CEG. Also, the optimized main switch design will be implemented.

IV. REFERENCES

- [1] S. B. Swanekamp, et al., Phys. Plasmas **7**, 5214 (2000); G. Cooperstein, et al., Phys. Plasmas to be published; and R. J. Comisso, et al., submitted to IEEE Trans. Plasma Sci.
- [2] F. Bayol, et al., this conference.
- [3] D. D. Hinshelwood, NRL Memorandum Report 5185 (1983), unpublished.

III. Summary and Future Work

In summary, ASTERIX was modified to carry out rod-pinch diode experiments up to 4 MV, and a new transmission line model for the front-end was developed in order to evaluate the electrical measurements. ASTERIX was converted to positive polarity by reversing the stacked-ring insulator, reducing the Marx voltage, and widening the main switch gap. The rod-pinch load was modeled using BERTHA to aid in the hardware design and to demonstrate the need for pre-pulse suppression. A vacuum pre-pulse switch was added to the front-end at a position determined by field analysis and was demonstrated to be effective by experiment. A new main switch with optimal geometry for positive polarity was designed. The limitations of inductive correction for calculating the load voltage were found. A new

^[1] S.B. Swanekamp

^[2] Fred

^[3] Bertha