

**FINAL  
ENVIRONMENTAL ASSESSMENT**

**BOLES WELLS FIELD PERIMETER SECURITY  
IMPROVEMENT PROJECT  
OTERO COUNTY, NEW MEXICO**

**U.S. AIR FORCE  
HOLLOMAN AIR FORCE BASE  
49<sup>TH</sup> FIGHTER WING  
49 CES/CEV**

**OCTOBER 2005**

# Report Documentation Page

Form Approved  
OMB No. 0704-0188

Public reporting burden for the collection of information is estimated to average 1 hour per response, including the time for reviewing instructions, searching existing data sources, gathering and maintaining the data needed, and completing and reviewing the collection of information. Send comments regarding this burden estimate or any other aspect of this collection of information, including suggestions for reducing this burden, to Washington Headquarters Services, Directorate for Information Operations and Reports, 1215 Jefferson Davis Highway, Suite 1204, Arlington VA 22202-4302. Respondents should be aware that notwithstanding any other provision of law, no person shall be subject to a penalty for failing to comply with a collection of information if it does not display a currently valid OMB control number.

1. REPORT DATE <b>03 OCT 2005</b>		2. REPORT TYPE		3. DATES COVERED <b>00-00-2005 to 00-00-2005</b>	
4. TITLE AND SUBTITLE <b>Final Environmental Assessment for the Boles Wells Field Perimeter Security Improvement Project Otero County, New Mexico</b>				5a. CONTRACT NUMBER	
				5b. GRANT NUMBER	
				5c. PROGRAM ELEMENT NUMBER	
6. AUTHOR(S)				5d. PROJECT NUMBER	
				5e. TASK NUMBER	
				5f. WORK UNIT NUMBER	
7. PERFORMING ORGANIZATION NAME(S) AND ADDRESS(ES) <b>49th Civil Engineer Squadron (49 CES/CEAO),550 Tabosa Avenue,Holloman AFB,NM,88330</b>				8. PERFORMING ORGANIZATION REPORT NUMBER	
9. SPONSORING/MONITORING AGENCY NAME(S) AND ADDRESS(ES)				10. SPONSOR/MONITOR'S ACRONYM(S)	
				11. SPONSOR/MONITOR'S REPORT NUMBER(S)	
12. DISTRIBUTION/AVAILABILITY STATEMENT <b>Approved for public release; distribution unlimited</b>					
13. SUPPLEMENTARY NOTES					
14. ABSTRACT					
15. SUBJECT TERMS					
16. SECURITY CLASSIFICATION OF:			17. LIMITATION OF ABSTRACT	18. NUMBER OF PAGES	19a. NAME OF RESPONSIBLE PERSON
a. REPORT <b>unclassified</b>	b. ABSTRACT <b>unclassified</b>	c. THIS PAGE <b>unclassified</b>			

**FINAL ENVIRONMENTAL ASSESSMENT  
FOR THE  
BOLES WELLS FIELD PERIMETER SECURITY IMPROVEMENT  
PROJECT  
OTERO COUNTY, NEW MEXICO**

Prepared for:



*U.S. Air Force  
49<sup>th</sup> Fighter Wing  
49 CES/CEV*

*October 3, 2005*

# **Finding of No Significant Impact for the Boles Wells Field Perimeter Security Improvement Project Holloman Air Force Base, New Mexico**

## **1.0 Name of Action and Description of Purpose**

The Boles Wells Field Perimeter Security Improvement Project is proposed to provide clear boundary demarcation, and to delay and deter trespass, for the Boles Wells Field of the Boles Wells Water System Annex (BWWSA) of Holloman Air Force Base. Located approximately 5 miles south of downtown Alamogordo, NM, adjacent to the western foothills of the Sacramento Mountains, the primary purpose of the BWWSA is to provide a safe source of potable water for HAFB.

## **1.1 Background**

The Boles Wells property is the northernmost unit of the BWWSA, and was acquired in fee simple by the United States Air Force (USAF) in 1956. A new barbed wire boundary fence was built in 1957. The 1957 fence was considered adequate until 1989, when it was replaced by new barbed wire on metal T- posts on the North, East, and South, and new wire was strung on railroad-tie posts on the West. These fences were aging, but considered adequate until passage of legislation requiring higher protection. As required by Public Law 107-188, Public Health Security and Bio-terrorism Preparedness and Response Act of 2002, security vulnerabilities were identified in a Water Vulnerability Assessment (WVA) and supplemental Risk Assessment prepared for Holloman AFB.

## **2.0 Description of Proposed Action and Alternatives**

The USAF proposes to reduce perimeter security vulnerabilities of the Boles Wells Field. These activities are to take place entirely upon lands solely owned by the USAF.

## **2.1 Proposed Action**

The USAF proposes security improvement in the form of a new perimeter security fence and maintenance of an approximately 15-foot wide area around the inside perimeter of the Boles Wells Field property boundary. The existing barbed wire would be separated from the posts, bundled, and rolled, to prepare it for removal from the site. The well field would be surveyed and staked to determine the proper boundaries as well as the location and size of easements that exist adjacent to the property boundaries. All posts, including some recently installed in concrete that do not align with survey determinations or avoid drainages, would be removed from the ground. An approximately 15-foot wide swath would be bladed to assist crews with construction and HAFB staff with subsequent patrol and maintenance of the fence. Contract language would be included to specify the limit of permissible ground disturbance allowed during construction of the new fence and that the construction effects must be limited to USAF Lands. Construction crews would auger approximately 3,300 holes two feet deep and install 3,300 metal posts set in concrete. Five-foot chain link fence would be installed on the posts.

## **2.2 Alternative Fencing Materials**

Alternative fencing materials such as barbed-wire or wood were considered for the construction of the security fencing surrounding the Boles Wells Field area but were determined not to be as effective due to their high level of maintenance and their lack of resistance to intrusion or vandalism. Wood fencing requires higher levels of maintenance due to exposure to the elements. Barbed-wire fencing is easily cut, traversed and compromised. Many alternative wire pattern

fencing materials do not greatly improve on the security provided by basic barbed-wire, and more impenetrable wire fences approach costs equivalent to chain link. Based on the higher levels of maintenance, lower resistance to trespass and vandalism, or costs approaching chain link costs, these alternatives were not considered viable alternatives and were eliminated from further study in the EA.

### **2.3 24/7 Manned Security Alternative**

The 24/7 Manned Security Alternative would require greater manpower resources in that four dedicated personnel would be required. No additional personnel beyond the initial construction phase would be required for the preferred alternative. Additionally, this alternative requires the use of support vehicles and equipment, necessitating greater long-term maintenance requirements than the preferred alternative. Therefore, based on the greater long-term requirement in manpower, vehicles, and equipment, this alternative was determined not to be viable.

### **2.4 24/7 Video Monitoring Alternative**

The 24/7 Video Monitoring Alternative would also require greater manpower resources because two dedicated personnel would be required to monitor the video perimeter surveillance. Long-term maintenance would be associated with the video equipment, dedicated vehicle, and back up power source(s). Additional costs and environmental disturbance would be associated with both the construction of four 15-foot camera towers, and providing power to the remote areas. A further concern with this alternative is a greater potential for vandalism of remote surveillance and backup power equipment. Based on higher costs for manpower, a dedicated vehicle, video surveillance equipment, and long-term maintenance, along with a greater potential for vandalism, this alternative was determined to be not viable.

### **2.5 No Action Alternative**

Under this alternative, the current fence line would not be replaced and the existing security of the Boles Wells Field would not change. Gaps in perimeter barriers would continue to exist, and pedestrian access to the property would not be curtailed. Vehicles and pedestrians would be allowed within a few feet of well heads that control water supply to HAFB. Boles Wells Field would potentially continue to be seen as a publicly available property, as even the most innocent trespassers would be unable to distinguish some parts of the well field boundaries.

## **3.0 Environmental Impacts of the Proposed Action**

As required by the National Environmental Policy Act (NEPA), this EA evaluated the potential environmental impacts associated with the Proposed Action. The findings for each resource area are described below.

### **3.1 Soil Resources**

Under the proposed project, approximately 15 acres of ground would again be disturbed as a result of clearing, grading and equipment activity in the area. Some erosion control features, such as silt fencing, have already been installed within the project area. Any incorrectly installed controls would be replaced with properly located and constructed features. Additional measures used to minimize or mitigate wind and water erosion would be described in the Stormwater Pollution Prevention Plan (SWPPP) that would be submitted by the contractor, and approved by the U.S. Air Force, in fulfillment of the USEPA requirements for a Construction General Permit under the National Pollutant Discharge Elimination System program. Once minimization and mitigation procedures as outlined in an acceptable SWPPP are followed, and design requirements that allow

the spanning of the fence over any drainage are implemented, there would be no long-term significant impacts to soils caused by implementing the Proposed Action.

### **3.2 Water Resources**

Under the dictated design and proper execution of erosion control techniques as would be outlined in the SWPPP, and the design and installation considerations given to surface water channels, no significant short or long-term impacts to water resources would result from the Proposed Action. Additionally, there would be a beneficial impact on existing ground water resources from increased protection and security of the Boles Wells Field area.

### **3.3 Air Quality**

Air emissions from construction activities under the Preferred Alternative would be similar to those produced during typical light-construction activities. Light-duty and medium-duty trucks would be used to haul away waste materials, deliver new fencing materials to specific installation areas, a small generator may power equipment such as augers, and heavy equipment will only be used to grade the perimeter within the project area. Fugitive dust from equipment travel and activity would also be produced, if only from isolated movement of small numbers of construction vehicles moving in isolated patterns during construction activity. Topography and meteorology of the area in which the project is located would not seriously restrict dispersion of the air pollutants. Any emissions discharged during construction of the proposed project are not expected to cause an increase in local air pollutant concentrations beyond state and federal standards at any time. Only insignificant short-term impacts are expected from the construction phase of the proposed project. No long-term impacts to air resources would be anticipated.

### **3.4 Natural Resources**

**Upland Vegetation.** The proposed area for fence erection has been previously cleared of most vegetation. If the area is to be re-bladed as part of the proposed project, an insignificant number of common shrubs and herbaceous vegetation typical of disturbed areas would be removed. A clear zone of approximately 15 feet would be maintained for patrol and maintenance along the fence line.

### **3.5 Drainages**

Several arroyos and other drainage features traverse the perimeter of Boles Wells Field. Posts would be set in even intervals along the property line, except where these drainages occur. Construction crews would be instructed to avoid placement of posts in beds of even the shallowest of drainage cuts. Rather, posts would be placed to allow the attached chain link material to span over these depressions, allowing water to flow unimpeded under the fence. These small drainages change course and depth naturally and frequently as a result of runoff events and actions taken by the adjacent property owners. Long term monitoring by HAFB well field and Natural Resources personnel will watch for and clear flow obstructions. The small drainages will serve as access points for small wildlife that might not otherwise be able to cross the fence line. The larger drainages will be spanned at bank level, both to allow larger animal passage and to leave an open channel for larger runoff events.

### **3.6 Wildlife**

Fencing material would be converted from the currently in place five strand barbed wire fence, designed in such a manner that prevents only large livestock, such as cattle, from crossing, to a more selective material of greater height. The upgrade to five-foot chain link fence may hinder the movement of animals such as coyote, porcupine, rabbit, and other small mammals across the

property boundaries. In an effort to alleviate this potential effect, the fence would be designed in such a way to preserve the ease of movement on and off the property via the network of drainages that cross in and out of the well field. By allowing the chain link material to span the drainages, wildlife would be afforded ample opportunity to pass through the approximately 25 openings ranging in depth from six inches to approximately 30 inches.

**Sensitive Species.** Both the Texas horned lizard and the loggerhead shrike are known to occur in the area. Any individuals present in the proposed project area likely to temporarily relocate during construction and reoccupy habitat once work is complete. Short-term impacts may occur to biological resources. Both the New Mexico Department of Game and Fish and the U.S. Fish and Wildlife Service have concurred that the Proposed Action is not expected to cause a significant impact to any biological resources.

### **3.7 Cultural and Historical Sites**

The 17 Isolated Occurrences found within the project area are not eligible for nomination for the National Register of Historic Places (NRHP). Thus, the Preferred Alternative would not result in an adverse effect on these resources. All the archaeological sites in the project area have been previously disturbed by perimeter road maintenance. One site near the project area had been previously identified as eligible for inclusion on the NRHP; however, it will not be affected by the Proposed Action and no further work is warranted. Four other sites in the project area are determined potentially eligible, or are of undetermined eligibility, and so they must be treated as if they are eligible under the NRHP. All four sites contain intact archeological deposits in undisturbed portions of the site and the Proposed Action will not adversely affect them. However, these sites will be prominently flagged or fenced during construction of the proposed fence line to contain the construction activities within the 15-foot wide construction corridor.

### **3.8 Land Use.**

Only short-term insignificant impacts would be expected during the construction phase of the Proposed Action. No long-term impacts are anticipated.

### **3.9 Aesthetics and Noise Resources**

Only short-term impacts would be expected to aesthetics during the construction phase of the project. No long-term impacts are anticipated due to the type of fencing material proposed. For noise resources, only insignificant impacts are anticipated during the construction phase and no long-term impacts are expected.

### **3.10 Hazardous and Solid Wastes.**

No hazardous waste would be generated by the proposed fence installation. No short- or long-term impacts are expected from the Proposed Action.

### **3.11 Socioeconomics and Environmental Justice**

No short- or long-term impacts are expected to socioeconomic resources from the implementation of the Proposed Action. Furthermore, as the entire project would be located within land owned by the U.S. Air Force, activities at Boles Wells Field and surrounding properties would continue undisturbed by this project. No long-term substantial impacts would be expected for environmental justice concerns.

#### 4. Conclusion

The cumulative impacts of the proposed project, the previous wellhead fencing project, the proposed but unfunded fencing of a portion of Boles Wells on the west side of US 54, and other geographically separate additional perimeter security projects are very similar to those of the proposed project. All known or anticipated projects are located in essentially similar settings, involve essentially similar construction procedures, equipment and affects, but are much smaller in scale. Because the significantly larger work addressed in this EA is reasonably expected to not result in significant effects, it is also reasonable to expect that the inclusion of smaller additional projects would result in no major change to the significance of cumulative impacts

The Preferred Action Alternative is expected to have short-term insignificant impacts on air resources, land use, geological resources, water resources, terrestrial wildlife, noise, aesthetic resources, and solid wastes. These are all related to construction activities. No impacts on threatened or endangered species, cultural resources, or environmental justice concerns are anticipated. No significant long-term impacts and no significant cumulative impacts are anticipated from implementation of the proposed project.

Based on the potential impact findings of the Final Environmental Assessment of the Boles Wells Field Security Improvement Project, dated 3 Oct 05, no significant impact on human health or the natural environment is anticipated as a result of the implementation of the proposed action. A Finding of No Significant Impact is warranted and an Environmental Impact Statement is not required for this action.

DEC 18 2005

  
KURT A. CICHOWSKI  
Brigadier General, USAF  
Commander

## EXECUTIVE SUMMARY

The Boles Wells Water System Annex (BWWSA) of Holloman AFB (HAFB) begins approximately 5 miles south of downtown Alamogordo, NM, adjacent to the western foothills of the Sacramento Mountains. The primary purpose of the annex is to provide a safe source of potable water for HAFB. The southern portion of the annex borders McGregor Range, Fort Bliss, while lands to the east are under jurisdiction of the Bureau of Land Management (BLM) and the U.S. Forest Service (USFS). To the west is a mosaic of private, state and BLM lands.

The Boles Wells property is the northernmost unit of the BWWSA, and was acquired in fee simple by the USAF in 1956. A new barbed wire boundary fence was built in 1957. The 1957 fence was considered adequate until 1989, when it was replaced by new barbed wire on metal T-posts on the North, East, and South, and new wire was strung on railroad-tie posts on the west. These fences were considered adequate until passage of legislation requiring higher protection. As required by PL 107-88, *Public Health Security and Bioterrorism Preparedness and Response Act of 2002*, security vulnerabilities were identified in a Water Vulnerability Assessment (WVA) and supplemental Risk Assessment prepared for Holloman AFB.

The USAF proposes installation of a new security fence, and maintenance of a bladed 12 to 15-foot wide area, completely around the inside perimeter of the Boles Wells Field Property boundary to reduce security vulnerability and mitigate trespass hazards. These activities are to take place entirely upon lands solely owned by the USAF.

This Environmental Assessment (EA) addresses the environmental aspects of the project area that would potentially be affected by, or in some way influence, the proposed project. They include: soils, water resources, air quality, biological resources, including vegetation, wildlife, and sensitive species, cultural resources, land use, aesthetics, including visual resources and noise, solid and hazardous waste, and socioeconomic, population, employment/earnings, and environmental justice affects.

In addition to the Preferred Alternative, the 1) No-Action Alternative; 2) Alternative Fence Materials; 3) 24/7 Manned Security Alternative; and, 4) 24/7 Video Monitoring Alternative were considered. The No-Action Alternative was carried throughout the analysis, and is reflected in the baseline environmental conditions of the area. The other alternatives were eliminated from consideration without further analysis because they entailed a higher level of long-term maintenance; greater requirements in cost, manpower, vehicles, and equipment; required electric power and video surveillance equipment; and entailed the same or greater security and environmental concerns as the Preferred Action Alternative.

The Preferred Action Alternative is expected to have short-term insignificant impacts on air resources, land use, geological resources, water resources, terrestrial wildlife, noise, aesthetic resources, and solid wastes; all related to construction activities. No impacts on threatened or endangered species, cultural resources, or environmental justice concerns are anticipated. No significant long-term, and no significant cumulative, impacts are anticipated from implementation of the proposed project. A Finding of No Significant Impacts is recommended.

---

## TABLE OF CONTENTS

<b>1.0</b>	<b>INTRODUCTION.....</b>	<b>1-1</b>
1.1	BACKGROUND .....	1-1
1.1.2	Boles Wells Field Perimeter Fencing, Background.....	1-2
1.2	PURPOSE AND NEED FOR THE ACTION .....	1-2
1.3	SCOPE OF THE ENVIRONMENTAL ASSESSMENT .....	1-61.3.1
	Scoping .....	1-6
1.3.2	Environmental Impact Analysis.....	1-6
1.4	REGULATORY COMPLIANCE .....	1-7
<b>2.0</b>	<b>PROPOSED ACTION AND ALTERNATIVES.....</b>	<b>2-1</b>
2.1	PROPOSED ACTION.....	2-1
2.2	PREFERRED ALTERNATIVE .....	2-1
2.2.1	Construction Activity.....	2-1
2.2.2	Actions to Reduce Potential for Environmental Impacts.....	2-2
2.3	ALTERNATIVE FENCING MATERIALS.....	2-2
2.4	24/7 MANNED SECURITY ALTERNATIVE.....	2-2
2.5	24/7 VIDEO MONITORING ALTERNATIVE .....	2-2
2.6	NO ACTION ALTERNATIVE.....	2-3
2.7	EVALUATION CRITERIA .....	2-3
2.8	ALTERNATIVES ELIMINATED FROM DETAILED STUDY .....	2-3
2.8.1.	Alternative Fencing Materials.....	2-3
2.8.2	24/7 Manned Security Alternative .....	2-4
2.8.3	24/7 Video Monitoring Alternative .....	2-4
2.9	COMPARISON OF VIABLE ALTERNATIVES .....	2-4
2.10	PUBLIC COMMENTS.....	2-5
<b>3.0</b>	<b>AFFECTED ENVIRONMENT .....</b>	<b>3-1</b>
3.1	SOILS .....	3-1
3.1.1	Definition of Resource .....	3-1
3.1.2	Existing Conditions.....	3-1
3.2	WATER RESOURCES .....	3-2
3.2.1	Definition of Resource .....	3-2
3.2.2	Existing Conditions.....	3-2
3.3	AIR QUALITY .....	3-3
3.3.1	Definition of Resource .....	3-3
3.3.2	Existing Conditions.....	3-5
3.4	BIOLOGICAL RESOURCES .....	3-5
3.4.1	Definition of Resource .....	3-5
3.4.2	Existing Conditions.....	3-6
3.5	CULTURAL RESOURCES .....	3-8
3.5.1	Definition of Resource .....	3-8
3.5.2	Existing Conditions.....	3-9
3.6	LAND USE.....	3-12
3.6.1	Definition of Resource .....	3-12
3.6.2	Existing Conditions.....	3-12

---

3.7	AESTHETICS AND NOISE .....	3-12
3.7.1	Definition of Resource .....	3-12
3.7.2	Existing Conditions .....	3-13
3.8	SOLID AND HAZARDOUS WASTE .....	3-13
3.8.1	Definition of Resource .....	3-13
3.8.2	Existing Conditions .....	3-14
3.9	SOCIOECONOMICS .....	3-14
3.9.1	Definition of Resource .....	3-14
3.9.2	Existing Conditions .....	3-14
3.10	ENVIRONMENTAL JUSTICE .....	3-15
3.10.1	Definition of Resource .....	3-15
3.10.2	Existing Conditions .....	3-16
<b>4.0</b>	<b>ENVIRONMENTAL CONSEQUENCES .....</b>	<b>4-1</b>
4.1	SOIL RESOURCES .....	4-1
4.1.1	Methodology .....	4-1
4.1.2	Potential Impacts .....	4-1
4.2	WATER RESOURCES .....	4-2
4.2.1	Methodology .....	4-2
4.2.2	Potential Impacts .....	4-2
4.3	AIR QUALITY .....	4-3
4.3.1	Methodology .....	4-3
4.3.2	Potential Impacts .....	4-3
4.4	BIOLOGICAL RESOURCES .....	4-4
4.4.1	Methodology .....	4-4
4.4.2	Potential Impacts .....	4-4
4.5	CULTURAL RESOURCES .....	4-6
4.5.1	Methodology .....	4-6
4.5.2	Potential Impacts .....	4-6
4.6	LAND USE .....	4-7
4.6.1	Methodology .....	4-7
4.6.2	Potential Impacts .....	4-7
4.7	AESTHETICS AND NOISE .....	4-8
4.7.1	Methodology .....	4-8
4.7.2	Potential Impacts .....	4-8
4.8	SOLID AND HAZARDOUS WASTE .....	4-9
4.8.1	Methodology .....	4-9
4.8.2	Potential Impacts .....	4-9
4.9	SOCIOECONOMICS .....	4-9
4.9.1	Methodology .....	4-9
4.9.2	Potential Impacts .....	4-10
4.10	ENVIRONMENTAL JUSTICE .....	4-10
4.10.1	Methodology .....	4-10
4.10.2	Potential Impacts .....	4-10
<b>5.0</b>	<b>CUMULATIVE IMPACTS .....</b>	<b>5-1</b>
<b>6.0</b>	<b>LIST OF PREPARERS .....</b>	<b>6-1</b>
<b>7.0</b>	<b>PERSONS AND AGENCIES CONTACTED .....</b>	<b>7-1</b>

---

<b>8.0</b>	<b>ACRONYMS</b> .....	<b>8-1</b>
<b>9.0</b>	<b>REFERENCES</b> .....	<b>9-1</b>

### FIGURES AND TABLES

Figure 1-1	General Location Map.....	1-3
Figure 1-2	Otero County Land Ownership and Use .....	1-4
Figure 1-3	Project Area Site Map .....	1-5
Table 1-1	Potential Permit Requirements .....	1-7
Table 2-1	Potential Environmental Impacts of the Proposed Alternatives.....	2-4
Table 3-1	Air Pollutant Concentration Standards.....	3-4
Table 3-2	Regional Chronology.....	3-9
Table 3-3	Five-Year Employment Comparison for Otero County .....	3-15

### APPENDICES

Appendix A	Site Photos
Appendix B	Engineering Plans
Appendix C	Threatened, Endangered, and Rare Species Information
Appendix D	Public Notice
Appendix E	Public Comments

---

## 1.0 INTRODUCTION

This Environmental Assessment (EA) addresses a proposal by the U.S. Air Force (USAF) to implement an Anti-Terrorism/Force Protection (ATFP) project to improve the security of the Boles Wells Field, the northernmost field of the Boles Wells Water System Annex (BWWSA), by upgrading perimeter protection. The BWWSA includes the geographically separated San Andres and Douglas Well Fields, which are not affected by this project. This EA is prepared in accord with the National Environmental Policy Act, 1969 (NEPA, 42 United States Code [USC] 4321-4347), the Council on Environmental Quality (CEQ) Regulations for Implementing the Procedural Provisions of NEPA (40 Code of Federal Regulations [CFR] 1500-1508), and Air Force Instruction (AFI) 32-7061, Environmental Impact Analysis Process (EIAP) as promulgated in 32 CFR 989.

In this case, the proposed security improvement construction was initiated prior to completion of either an EA or an Archaeological Survey. This breach of policy happened because multiple work orders were submitted to the 49<sup>th</sup> Civil Engineer Squadron, each requesting some level of fence repair or fence replacement. One of those work orders, requesting only partial repair of the existing fence, had been reviewed and approved by the Environmental staff, but was funded and contracted as a 49 CES/CEV complete replacement of the existing fence. Proper coordination and assessment of the actual project were not completed when the contract was let. The internal perimeter road was freshly bladed, part of the north boundary fence dismantled and some new poles were set, when the work was stopped due to a public request to review the environmental documentation for the project. Arrangements were then made to conduct this analysis, provide draft copies to the concerned public, hold a public information meeting, and perform an Archaeological Damage Assessment (Trierweiler & Swain, 2005). This process has now been completed and is in final form. The Civil Engineering work order tracking, control, and integration processes and personnel have been changed to guard against any future recurrence of this problem.

This EA addresses the environmental aspects of the project area that would potentially affect or be affected by the proposed project. These are: soils, water resources, air quality, biological resources (wildlife, plants, sensitive species), cultural resources, land use, aesthetics (visual and aural), solid and hazardous waste, socioeconomics (population, employment) and environmental justice. Chapter 1 provides background and overview of the proposed project, the purpose and need for the Proposed Action, the scope of the EA and regulatory compliance requirements. Chapter 2 describes the Proposed Action and Alternatives. Chapter 3 provides a description of the affected environment and resources. Chapter 4 discusses the environmental impacts of the Preferred Alternative and No Action Alternative. Chapter 5 summarizes cumulative consequences of the Proposed Action in combination with other recent, ongoing, or reasonably foreseeable projects in the affected area.

### 1.1 BACKGROUND

The BWWSA of Holloman AFB (HAFB) begins approximately 5 miles south of downtown Alamogordo (Figure 1-1), adjacent to the western foothills (bajada) of the Sacramento Mountains. The annex is comprised of three well fields referred to as Boles, Douglas, and San Andres, dispersed over about 12 miles north-south. The USAF has jurisdiction of over 6,922.7 acres, which include public lands withdrawn for military purposes and Air Force lands owned in fee simple.

---

The primary purpose of the annex is to help provide a continuous source of potable water for HAFB. The southern portion of the BWWSA borders McGregor Range of Fort Bliss, U.S. Army. Lands to the east of the annex are mostly under jurisdiction of the Bureau of Land Management (BLM) and the Lincoln National Forest. In between, and to the west of the well fields, is a mosaic of private lands, BLM lands, and U.S. Park Service lands (White Sands National Monument). An overview map depicting general land ownership for Otero County is provided in Figure 1-2.

Boles Wells Field is a separate property at the north end of the BWWSA. It is bordered on the west by a Southern Pacific Railways main line and U.S. Highway 54. Taylor Ranch Road runs east-west roughly parallel to the southern border, while the eastern border is paralleled by the Old El Paso Highway. Residential tracts adjoin the north line and parts of the southern border (Figure 1-3).

### **1.1.2 Boles Wells Field Perimeter Fencing, Background**

The Boles Wells property was acquired by the USAF in 1956, to assure a reliable water source for HAFB. An earlier real property interest had been negotiated, but by the 1950's, it was deemed inadequate to completely control and protect the water supply. Thus, in 1956, condemnation proceedings were completed giving the USAF the Boles Wells property in fee simple. Because expenditures on federal real property must be tracked, HAFB retains records from 1943 to present detailing past construction at Boles. Of direct interest to the discussion in this report, the first military-funded fence in the area to be effected was built on the existing fence alignment in 1943. The 1943 fence aged to the point that it was replaced by a new barbed wire fence in 1957. The 1957 fence was considered adequate until 1989, when it was again replaced by new barbed wire, on metal T- posts on the North, East, and South. The records do not specify when, but much of the west side fence on the Boles property was strung using railroad ties as posts, making a very stout fence. According to the memory of long time well field staff (Gomolak, Mendez 2004), there has "always" been a perimeter "road" around the interior of the Boles boundary fence, as shown in the first two site photos provided in Appendix A.

## **1.2 PURPOSE AND NEED FOR THE ACTION**

The purpose of this action is to improve the security of the HAFB water supply. The need is to remedy security vulnerabilities identified in a Water Vulnerability Assessment (WVA) published by the Air Force Institute for Operational Health (AFIOH, 2004) and an associated Risk Assessment prepared for HAFB. The Boles Wells Field has been identified as a critical water system component in the WVA. The WVA was conducted using the methodology presented in the guidance document "Water Vulnerability and Risk Assessment for Potable Water Assets", Air Force Institute for Operational Health, March 2003. The assessment complied with criteria outlined in Public Law (PL) 107-188, *Public Health Security and Bioterrorism Preparedness and Response Act of 2002*, which contains an amendment to the Safe Drinking Water Act (SDWA), Section 1433, "Terrorist and Other Intentional Acts." Section 1433 directs U.S. community water systems serving populations greater than 3,300 to conduct assessments for vulnerability to terrorist and other intentional acts intended to substantially disrupt the ability of systems to provide a safe and reliable supply of drinking water. Additionally, the Boles Wells Field was identified as an area requiring security measures in a threat assessment board conducted by the installation Wing Commander.

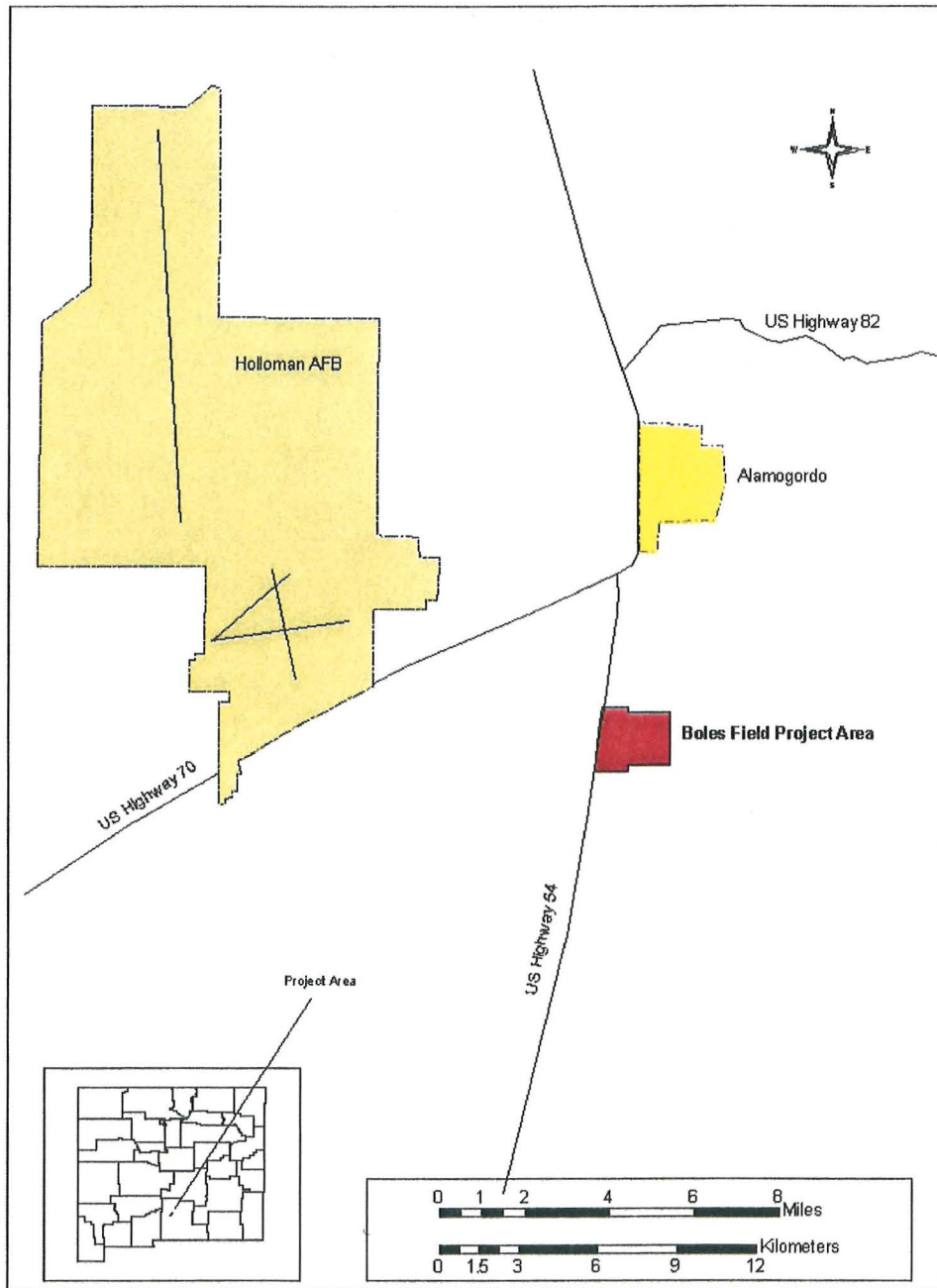

**FIGURE 1-1 GENERAL LOCATION MAP**

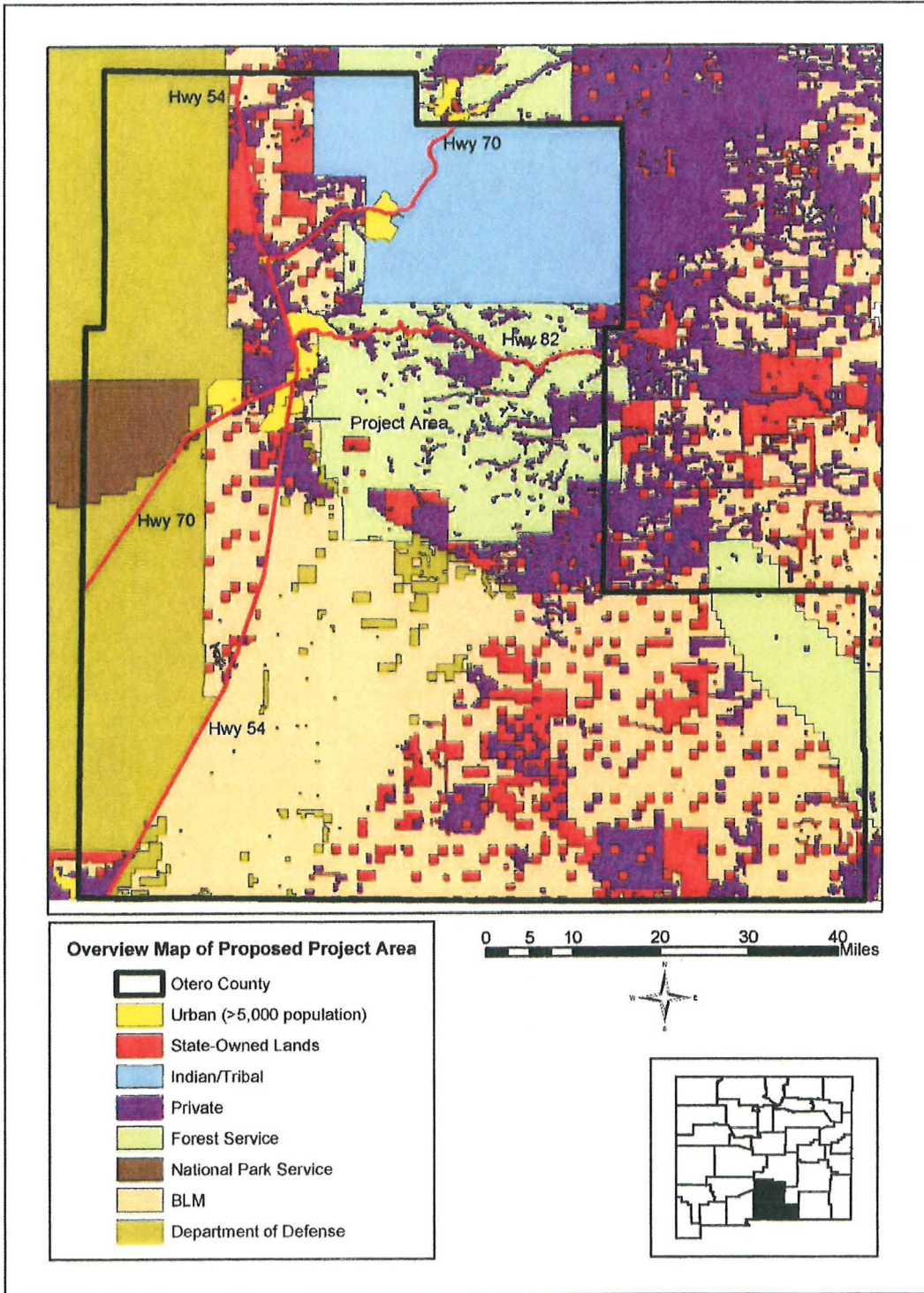

**FIGURE 1-2 OTERO COUNTY LAND OWNERSHIP AND USE**

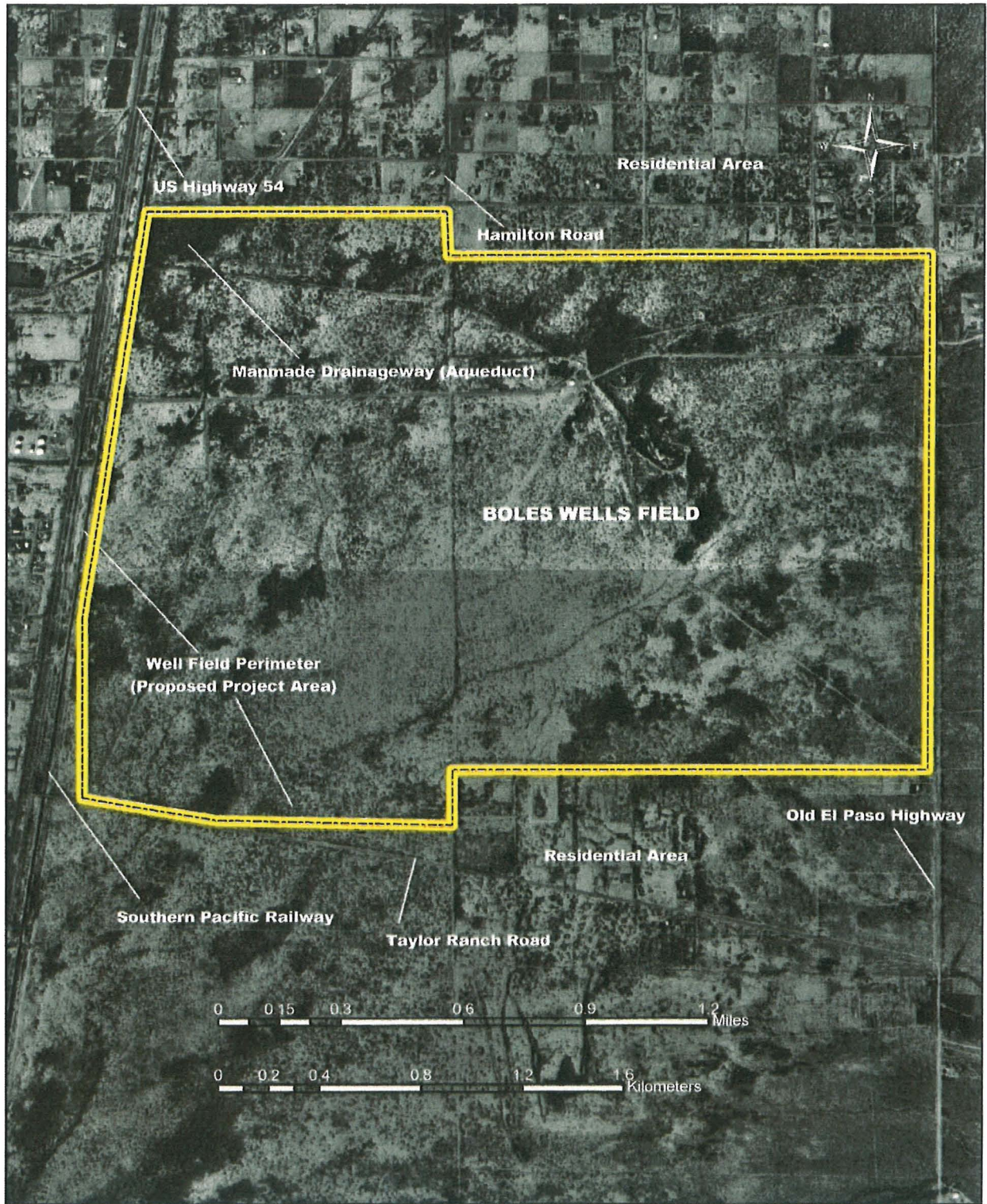

**FIGURE 1-3 PROJECT AREA SITE MAP**

---

Security vulnerability reduction is needed because potable water systems components are potentially vulnerable to contamination and/or supply disruptions from a host of threats. USAF Policy Directive 10-24, Air Force Critical Infrastructure Protection and Department of Defense (DoD) Directive 5160.54, Critical Asset Assurance Program, directs installation commanders to support and implement DoD critical asset assurance requirements to reduce vulnerabilities and mitigate hazards. The Boles Wells Field is a USAF Critical asset. Security is needed to reduce intentional threat vulnerabilities and mitigate supply disruption hazards. In an open public setting such as at Boles, security improvements could include a very wide range of simple to extravagant solutions, yet the minimum selection criteria remain: 1) Clearly delineate the boundary; 2) Deter trespass; and 3) Delay attempted offenders by constructing layers of protection. Future studies and funding may result in additional layers of security improvement, beyond this basic current proposal.

### **1.3 SCOPE OF THE ENVIRONMENTAL ASSESSMENT**

#### **1.3.1 Scoping**

Several environmental concerns were identified to address in the EA. These were based on the nature of the proposed work and an understanding of local conditions.

- Potential for hindrance to wildlife movement throughout the project area;
- Potential for ground disturbance to affect sensitive or protected species and/or their habitat;
- Potential for construction impacts to cultural resources; and
- Potential for impedance of proper water drainage and aesthetics on upstream lands.

Opportunity to comment on the selection criteria, the scope, and this resulting analysis, was provided to federal and state agencies, the city of Alamogordo, Otero County and to concerned citizens by mail; and, by a public meeting held in Alamogordo, New Mexico on 4 May 2005, within three weeks of the release of the Final Draft document. The meeting was well attended, entailed a lively discussion, and written public comments were received (see Appendix E).

#### **1.3.2 Environmental Impact Analysis**

This EA addresses potential impacts that could result from implementing the perimeter security project. It examines potential impacts generated directly from construction activities, and the environmental benefits or disadvantages of alternatives to the proposed project. A field survey was conducted by contract archeologists and a biologist on June 9 and 10, 2004. Previously drafted environmental documents relevant to the project area and proposed project were also used as part of this assessment. Based on identified issues and the types of activities involved, resources addressed include: soil, water, air, biological and cultural resources, land use, aesthetic resources, solid and hazardous waste, socioeconomics, and environmental justice.

The USAF or construction contractor would acquire any permits and licenses required for the perimeter security project. Environmental laws and regulations that may require permits include, but are not limited to: National Historic Preservation Act of 1979; Clean Water Act of 1977;

Endangered Species Act of 1973; Fish and Wildlife Conservation Act of 1980; Historic Site Act of 1935; Noise Control Act of 1972; and Clean Air Act of 1970.

#### 1.4 REGULATORY COMPLIANCE

This EA has been prepared principally to comply with NEPA. It also addresses the proposed action's compliance with other applicable environmental laws and regulations. Table 1-1 summarizes the requirements of NEPA and reviews other key federal environmental regulatory requirements applicable to the proposed perimeter security project.

**TABLE 1-1 POTENTIAL PERMIT REQUIREMENTS**

<i>Type of Permit or Regulatory Requirement</i>	<i>Requirement</i>	<i>Agency</i>
National Environmental Policy Act	Required for approval of federal project.	Council on Environmental Quality, U.S. Department of the Air Force
Clean Water Act Section 404	Required for authorizing fill within wetlands or other waters of the U.S.	U.S. Army Corps of Engineers
Clean Water Act	National Pollutant Discharge Elimination System stormwater permit.	U.S. Environmental Protection Agency and State of New Mexico
Clean Air Act and Amendments	Establishes nationwide standards and requires conformity to state plans.	U.S. Environmental Protection Agency and State of New Mexico
National Historic Preservation Act	Requires federal agencies to consider potential impacts to cultural resources.	New Mexico State Historic Preservation Office
Executive Order (EO) 13084, Consultation and Coordination with Indian Tribal Governments	Required to consult with tribal entities on federal projects.	U.S. Department of Defense
EO 13112, Invasive Species	Required to prevent/control spread of invasive weeds from federal projects.	National Invasive Species Council (multiple agencies)
EO 11990, Protection of Wetlands	Required to avoid impacts to or loss of wetlands.	U.S. Army Corps of Engineers and State of New Mexico
EO 11988, Floodplain Management	Required to avoid effects on or development in floodplains.	U.S. Army Corps of Engineers and State of New Mexico
EO 12372, Intergovernmental Review of Federal Programs	Requires federal agencies to cooperate with and consider state and local views.	U.S. Air Force
EO 12898, Environmental Justice	Requires federal agencies to consider potential disproportionate effects on minority and low-income populations.	U.S. Air Force
EO 13045, Protection of Children from Environmental Health Risks and Safety Risks	Requires federal agencies to consider potential disproportionate health and safety risks to children.	U.S. Air Force
Endangered Species Act	Required to consult on impacts of project implementation on federally listed or proposed threatened and endangered species.	U.S. Fish and Wildlife Service and New Mexico Department of Game and Fish

---

## **2.0 PROPOSED ACTION AND ALTERNATIVES**

### **2.1 PROPOSED ACTION**

The USAF proposes to reduce perimeter security vulnerabilities of the Boles Wells Field located near Alamogordo, Otero County, New Mexico. The majority of the existing fence is five-strand barbed wired secured on iron "T" posts or wooden posts. Access to the well field may be easily achieved by climbing through or over the existing fence; further, tension was slack in some sections of the fence. The proposed action is to reduce security vulnerabilities and mitigate trespass hazards by upgrading the perimeter fence. These activities are to take place entirely upon lands solely owned by the USAF.

### **2.2 PREFERRED ALTERNATIVE**

The Preferred Alternative to accomplish the proposed action is to replace the dilapidated barbed-wire fence with approximately 33,000 linear feet of five-foot chain link fence installed on metal posts set in concrete, and maintain an approximately 15-foot wide clear zone around the interior perimeter of the Air Force property (see site plan in Appendix B). Other alternatives are discussed in Section 2.8.

#### **2.2.1 Construction Activity**

Construction would begin in the fall of 2005, and would continue for approximately three months. Prior to installation of the proposed fence, the existing fence must be removed. The existing barbed wire would be separated from the posts, bundled, and rolled, to prepare it for removal from the site. The well field would be surveyed and staked to determine proper boundaries, as well as location and size of easements that exist adjacent to the property boundaries. All posts, including those recently installed in concrete that do not align with survey determinations, would be removed from the ground. An approximately 15-foot wide swath would be bladed to assist crews with construction and staff with subsequent patrol of the fence. Contract language would be included to specify the limit of permissible ground disturbance allowed during construction of the new fence, and specifying that construction effects would be limited to only USAF Lands. Construction crews would auger approximately 3,300 holes two feet deep, and install 3,300 metal posts set in concrete. Five-foot chain link fence would be installed on the posts.

Several arroyos and other drainage features traverse the perimeter of Boles Wells Field. Posts would be set in even intervals along the property line, except where these drainages occur. Construction crews would be instructed to avoid placement of posts in beds of even the shallowest of drainage cuts. Rather, posts would be placed to allow the attached chain link material to span over these depressions, allowing water to flow unimpeded under the fence. These small drainages, which number in the dozens along the perimeter, change course and depth naturally and frequently as a result of runoff events and actions taken by the adjacent property owners, would also serve as access points for small wildlife that might not otherwise be

---

able to cross the fence line. The larger drainages will be spanned at bank level, both to allow larger animal passage and to leave an open channel for runoff events.

Best Management Practices (BMPs) would be used to control dust and soil erosion during construction. In general, any improvements that are removed or damaged would be replaced with similar structures and products.

Construction activity would disturb approximately 15 acres of land, all of which have been cleared and graded during past construction of the previous barbed-wire fences.

### **2.2.2 Actions to Reduce Potential for Environmental Impacts**

Several methods would be utilized to minimize potential impacts from construction. All construction or soil disturbance activity associated with the perimeter security project would occur on USAF property. Any plans, standards, or practices required by local, state, and federal law would be observed. Specific methods include:

- Storm Water Pollution Prevention Plan (SWPPP) prepared by the construction contractor in accordance with any local, state, and federal requirements. The plan would describe all methods used to control storm water runoff and soil erosion during and following construction;
- Heavy equipment and other construction vehicles would not be allowed in areas beyond the narrow limit of disturbance; and
- By terms of contract, any property or structures, including those of adjacent landowners, removed or damaged during construction would be repaired or replaced.

## **2.3 ALTERNATIVE FENCING MATERIALS**

As an alternative to chain-link fencing, alternative fencing materials such as barbed wire, woven wire, or wood were considered. An additive alternative was the installation of three wire outriggers and razor wire at the top of the chain-link fencing.

## **2.4 24/7 MANNED SECURITY ALTERNATIVE**

Under this alternative, four dedicated personnel, two dedicated support vehicles, and associated support equipment would be assigned to 1-12 hour shifts of security monitoring for the Boles Wells Field. No fence installation or repair would occur.

## **2.5 24/7 VIDEO MONITORING ALTERNATIVE**

Under this alternative, fourteen 15 foot tall towers, each equipped with two video camcorders would be installed, providing complete perimeter surveillance coverage. This alternative would require two 24/7 dedicated personnel, one for each 12 hour shift, a dedicated vehicle, electrical work, back up power generation, tower construction, tower protection and long-term video equipment operation and maintenance. No perimeter fence installation or repair would occur.

---

## **2.6 NO ACTION ALTERNATIVE**

Under this alternative, the current fence line would not be replaced and the existing security of the Boles Wells Field would not change. Gaps in perimeter barriers would continue to exist, and pedestrian access to the property would not be obviously prohibited. Vehicles and pedestrians would be allowed within a few feet of well heads that control water supply to HAFB without first crossing a distinct boundary. Boles Wells Field would potentially continue to be seen as a publicly available property, as even the most innocent trespassers would be unable to distinguish the well field boundaries.

## **2.7 EVALUATION CRITERIA**

Evaluation criteria of alternatives included the following:

- Perimeter protection capability,
- Long-term effectiveness,
- Manpower resources,
- Equipment resources,
- Long-term maintenance requirements,
- Impact of the remote location,
- Vandalism vulnerability,
- Exposure to elements, and
- Availability of electric power.

## **2.8 ALTERNATIVES ELIMINATED FROM DETAILED STUDY**

### **2.8.1. Alternative Fencing Materials**

Alternative fencing materials such as barbed wire or wood previously considered for the construction of the security fencing surrounding the Boles Wells Field area were not considered to be as effective due to their high level of maintenance and their lack of resistance to vandalism. Barbed-wire fencing is easily cut and traversed or compromised. Additionally, wood fencing requires a higher level of maintenance due to exposure to the elements, and barbed wire does little to assure that crossings do not occur. The alternative to install three wire-top outriggers and razor wire at the top of the chain-link fencing was considered more costly to install, would cause an excessive visual affect in the general area, and does not add an appreciable improvement in security over a basic chain link fence. Many alternative wire pattern fencing materials do not appreciably improve on the security provided by basic barbed wire, and more impenetrable wire fences approach costs equivalent to chain link. Based on the higher levels of maintenance, and/or lower resistance to trespass and vandalism, these alternatives were not considered to be viable alternatives and are eliminated from further study in this document.

---

### 2.8.2 24/7 Manned Security Alternative

The 24/7 Manned Security Alternative would require greater manpower resources in that four dedicated personnel would be required. No additional personnel beyond the construction phase would be required for the preferred alternative. Additionally, this alternative requires support vehicles and equipment, with greater long-term maintenance requirements than the preferred alternative. Based on the greater requirements for manpower, vehicles, equipment, and maintenance, this alternative was not considered to viable, and is eliminated from further study.

### 2.8.3 24/7 Video Monitoring Alternative

The 24/7 Video Monitoring Alternative would also require greater manpower resources, as two dedicated personnel would be required to monitor video perimeter surveillance. Long-term maintenance would be associated with the video camcorder equipment, dedicated vehicle, and back up power source. Additional costs and environmental disturbance would be associated with both the construction of the 14-15 foot towers, as well as the power lines to the remote area. A further concern with this alternative is the greater potential for vandalism of remote surveillance and backup power generation equipment. Based on the lack of available electric power greater requirements for manpower, vehicle, and video surveillance equipment; long-term maintenance costs along with a greater potential for vandalism concerns, this alternative was not considered to be a viable alternative and is eliminated from further study.

## 2.9 COMPARISON OF VIABLE ALTERNATIVES

Table 2-1 summarizes the environmental impacts of the preferred alternative and the No Action alternative. These are carried through the document for further evaluation.

**TABLE 2-1 POTENTIAL ENVIRONMENTAL IMPACTS OF ALTERNATIVES**

Resource	Preferred Alternative	No Action Alternative
Soils	No significant impact with erosion control measures.	No Impact.
Water Resources	No significant impact to surface water resources with erosion control measures. Beneficial impact for ground water resources from protection and security of this area.	No impact to surface water resources. Possible protection and security exposure to ground water resources.
Air Quality	Short term impacts due to construction activities. No long term impacts anticipated.	No Impact.
Biological Resources	Insignificant loss of wildlife habitat; minimal effect from loss of small amount of scrubland vegetation.	Possible deterioration due to illegal foot and vehicle traffic in this area.

**TABLE 2-1 POTENTIAL ENVIRONMENTAL IMPACTS, CONTINUED**

Resource	Preferred Alternative	No Action Alternative
Cultural Resources	No short or long term impacts anticipated.	Possible deterioration due to illegal foot and vehicle traffic in this area.
Land Use	No long-term impact on land use resources.	Possible deterioration due to illegal foot and vehicle traffic in this area.
Aesthetics / Noise	Short term impacts due to construction activities. No long term impacts due to visibility allowed through fence material.	No Impact.
Solid Waste	Short term increase in solid waste materials – no impact as these would be properly disposed. No long term impacts anticipated.	Access to this area may lead to illegal dumping of solid waste items.
Socioeconomics	Beneficial change due to increased security of the area, and minor local benefit of construction jobs.	Security issues may continue under the No Action Alternative.
Environmental Justice	No Impact.	No Impact.

The decision makers are not bound to choose a “best” environmental alternative. Any alternative that meets the need within available resources and constraints may be selected as long as the National Environmental Policy Act process is followed, the alternatives are studied and considered, and the appropriate authority makes an informed decision.

## 2.10 PUBLIC COMMENTS

HAFB received agency review comments from the US Fish and Wildlife Service, the New Mexico Department of Game and Fish, the New Mexico Department of Environment, and White Sands National Monument. These agencies agreed that there are no significant environmental affects reasonably expected to result from construction of the five foot tall chain link fence around the perimeter of the Boles Wells Field.

Public comments included: one lengthy review letter discussing environmental and fiscal concerns; two shorter letters primarily addressing the need and fiscal aspects of constructing the preferred alternative; as well as three signed and one unsigned comment sheets written as a result of the public information meeting. The four comment sheets from the public meeting were supportive of the project and the proposed action.

The shorter letters proposing writer perceived alternatives, and in general casting doubt on the need and fiscal responsibility of building the proposed fence, are of some interest but did not generally address viable alternatives that would have appreciably different impact on the

---

environment. The Air Force (AF), as the security managing agency charged with protecting the water system under PL 107-188, 2002, is responsible to define the need and fiscal aspects of a project. In the case of this security improvement, the need was defined in accord with Air Force policy, and supported by a water system security vulnerabilities study (AFIOH, 2004) performed by higher authorities in the AF security establishment. The preferred alternative is a security driven AF defined compromise between factors of cost and effectiveness, and is to be a part of a layered defense plan to protect the well field.

The longer review and comment on this EA did raise several points which resulted in changes from the Public Draft to this Final document (See Appendix E). Other points raised will become part of the monitoring and maintenance routine for the Boles Wells boundary fence. However, the overall thrust of the longer review letter remained aimed at the need and fiscal responsibility of the proposed fence. As discussed above, the AF defined the security need in accordance with AF policy and guidance from higher levels, and chose a viable alternative. The discussion of fiscal responsibility is beyond the scope of an Environmental Analysis.

---

### **3.0 AFFECTED ENVIRONMENT**

This section describes the existing environmental and socioeconomic conditions of the potential region of impact for this proposed perimeter security project. This section provides information that should serve as a baseline from which to identify and evaluate any environmental and socioeconomic changes likely to result from the implementation of the Proposed Action.

In compliance with NEPA, CEQ guidelines and 32 CFR 989 et seq., the description of the affected environment focuses on those resources and conditions potentially subject to any impacts. These resources and conditions include: soils, water resources, air quality, biological and cultural resources, land use, aesthetics and noise, solid waste, socioeconomics and environmental justice.

#### **3.1 SOILS**

##### **3.1.1 Definition of Resource**

This section discusses soils within the region of influence because surface disturbance would result from implementation of the alternatives other than the No Action Alternative. Soils are comprised of unconsolidated weathered minerals and organic material at the ground surface in which plants grow. The area of influence for soils includes the approximately 15-foot wide area at the perimeter of Boles Wells Field. The underlying geology would not be affected and will only be characterized as it has influenced the soils described in the affected environment.

##### **3.1.2 Existing Conditions**

Soils in the Boles Wells Field were formed on flood plains and lower parts of the pediment slope, by drainages from the Sacramento Mountains immediately east of the project area. The materials are primarily calcareous alluvial material derived from limestone, deposited by the run-on water from the nearby uplands, as well as eolian material dropped out as the prevailing west winds rise to pass over the 9,000-foot-elevation mountain to the east.

The majority of the well field consists of Tome silt loam (TDB), a deep, well drained, nearly level to gently sloping soil with moderately slow permeability and high available water capacity. Two other types of soils, Largo-Ogral Complex (LGB) and Mimbres-Tome Association (MTA), are present in Boles Wells Field, though in lesser proportion than TDB soils. These are also deep, well-drained soils typical on low parts of pediments. LGB soils range from moderately slow to moderately rapid permeability, and from low to high water capacity availability. MTA soils are moderately permeable and have high water capacity availability (NRCS 1981.)

---

## **3.2 WATER RESOURCES**

### **3.2.1 Definition of Resource**

Water resources are both the water on and beneath the ground surface. Surface water is limited to minor intermittent drainages within the proposed project area, similar to Photo 1 in Appendix A. Ground water beneath the project area is recharged by surface and subterranean flow from the mountains to the East.

### **3.2.2 Existing Conditions**

The project area is located within the Tularosa Basin, which comprises approximately 5% of the greater Rio Grande drainage system, although no surface flow connects the Tularosa Basin to the modern Rio Grande. Precipitation on the surrounding mountain slopes runs via intermittent streams toward the center of the basin, or moves as ground water through alluvial deposits and permeable formations below the stream channels (NMISC 2002). The main perennial streams of the basin are the upper reaches of Three Rivers, Tularosa Creek and El Rito de La Luz (none of which are close to the current project area of affect). The basin is covered with deposits of gypsum, alluvial and aeolian sand, gravel, clay, and alkali flats of varying thickness, with basaltic lava beds in the northern portion of the valley.

No perennial streams exist within HAFB or surrounding area. Most precipitation events in the local ecosystem occur as summer monsoons and large storm events falling on the rocky slopes of the Sacramento Mountains. Precipitation is absorbed quickly by the gravels and silty sandy soils at the base of the alluvial fans. During these precipitation events, runoff that is not immediately absorbed flows down gradient via numerous shallow cuts and arroyos, which create a random network of drainages that abruptly end or gradually disappear as water seeps into the soil. During heavy precipitation events, flooding is common at lower elevations and the margins of the basin floor.

Groundwater recharge occurs largely from rainfall and snowmelt in the Sacramento Mountains, where intermittent stream flow infiltrates into the loosely consolidated, coarse, alluvial fan material. The Boles Wells Field area contains approximately 5.47 acres and 8,409 meters of jurisdictional waters of the U.S., including 0.72 acre of wetlands. These water resources include one non-vegetated ephemeral basin, one vegetated ephemeral basin, and one permanently flooded small constructed pond (USAF 1996).

The majority of the water supply of most of the Tularosa Basin, including HAFB, is provided by groundwater sources, although some surface water impoundments, such as Bonito Lake, supplement supply. Peak water usage for Holloman AFB in recent history has been about 3.5 million gallons per day (mgd), based on monthly data, with an average of about 2 mgd. Comparatively, the city of Alamogordo uses a peak of 8 mgd.

---

### 3.3 AIR QUALITY

#### 3.3.1 Definition of Resource

Air quality in a given location is determined by the concentration of various pollutants in the atmosphere. The significance of a pollutant concentration in a region or geographical area is determined by comparing it to federal and/or state ambient air quality standards. Under the authority of the Clean Air Act (CAA), the U.S. Environmental Protection Agency (USEPA) has established nationwide air quality standards to protect public health and welfare, with an adequate margin of safety. These federal standards, known as the National Ambient Air Quality Standards (NAAQS), represent maximum allowable atmospheric concentrations and were developed for six “criteria” pollutants: ozone (O<sub>3</sub>); nitrogen dioxide (NO<sub>2</sub>); carbon monoxide (CO); respirable particulate matter less than 10 micrometers in diameter (PM<sub>10</sub>); sulfur dioxide (SO<sub>2</sub>); and lead (Pb).

The USEPA designates areas of the U.S. as having air quality equal to or better than the NAAQS (attainment) or worse than the NAAQS (nonattainment). Former nonattainment areas that have recently achieved attainment of the NAAQS are designated as maintenance areas. Areas are designated as unclassifiable for a pollutant when there is insufficient ambient air quality data for the USEPA to form a basis of attainment status. The Boles project area is in Attainment status.

The NAAQS are defined in terms of concentration (e.g., parts per million [ppm] or micrograms per cubic meter [ $\mu\text{g}/\text{m}^3$ ]) determined over various periods of time called averaging periods. Short-term standards (1-hour, 8-hour, or 24-hour periods) were established for pollutants with acute health effects and may not be exceeded more than once per year. Long-term standards (annual periods) were established for pollutants with chronic health effects and may never be exceeded.

In 1997, the USEPA promulgated two new standards: a new 8-hour O<sub>3</sub> standard and a new standard called PM<sub>2.5</sub>, which are fine particles with diameters less than 2.5 microns that have not been previously regulated. In addition, the USEPA revised the existing PM<sub>10</sub> standard. The two new standards were scheduled for implementation over a period of several years, as monitoring data became available to determine the attainment status of areas in the U.S. However, the USEPA was challenged in courts on these new and revised standards, and in May 1999, the U.S. District of Columbia Court of Appeals issued a ruling stating that the CAA as applied and absent further clarification “effects an unconstitutional delegation of legislative power.” Furthermore, the court stated that:

- The new 8-hour O<sub>3</sub> standard was remanded back to the USEPA for further consideration and “cannot be enforced”;
- The new PM<sub>2.5</sub> standard was allowed to remain in place, but affected parties can apply to have this standard vacated under certain conditions; and,
- The revised PM<sub>10</sub> standard was vacated and replaced by the pre-existing PM<sub>10</sub> standard.

The case was appealed to the U.S. Supreme Court, and in February 2001, the court upheld the 8-hour O<sub>3</sub> standard and instructed the USEPA to develop a reasonable interpretation of the

nonattainment implementation provisions. The 8-hr averaged standard is determined by calculating the average of the fourth highest readings at each monitor over a three-year period. In April 2004, the USEPA designated 474 counties as non-attainment for the new 8-hour standard, and assigned maximum attainment periods for each.

Under the CAA, state and local agencies may establish air quality standards and regulations of their own, provided these are at least as stringent as the federal requirements. For selected criteria pollutants, the state of New Mexico has established its state ambient air quality standards (NMAAQS), which are somewhat more stringent than the federal standards. A summary of the federal and New Mexico ambient air quality standards that apply to the proposed project area is presented in Table 3-1.

**TABLE 3-1 AIR POLLUANT CONCENTRATION STANDARDS**

Air Pollutant	Averaging Time	Federal NAAQS (maximum levels)		NM State AAQS (maximum levels)	
		Primary	Secondary	Primary	Secondary
Total Suspended Particulates	24-hour avg	---	---	150 µg/m <sup>3</sup>	---
	7-day avg	---	---	110 µg/m <sup>3</sup>	---
	30-day avg	---	---	90 µg/m <sup>3</sup>	---
	AGM	---	---	60 µg/m <sup>3</sup>	---
Sulfur Dioxide (SO <sub>2</sub> )	24-hour avg	0.14 ppm	---	0.10 ppm	---
	AAA	0.03 ppm	---	0.02 ppm	---
	3-hr avg	---	0.5 ppm	---	0.5ppm
Hydrogen Sulfide (H <sub>2</sub> S)	1-hr avg	---	---	0.010 ppm	---
Total Reduced Sulfur	½-hr avg	---	---	0.003 ppm	---
		---	---	---	---
Carbon Monoxide (CO)	8-hr avg	9 ppm	---	8.7 ppm	---
	1-hr avg	35 ppm	---	13.1 ppm	---
Nitrogen Dioxide (NO <sub>2</sub> )	24-hr avg	---	---	0.10 ppm	---
	AAA	0.053 ppm	0.053 ppm	0.05 ppm	0.053 ppm
Ozone (O <sub>3</sub> )	8-hr avg	0.08 ppm	0.08 ppm	---	---
	1-hr avg	0.12 ppm	0.12 ppm	0.12 ppm	0.12 ppm
Particulate Matter (PM <sub>10</sub> )	24-hr avg	150 µg/m <sup>3</sup>	150 µg/m <sup>3</sup>	---	150 µg/m <sup>3</sup>
	AAM	50 µg/m <sup>3</sup>	50 µg/m <sup>3</sup>	---	50 µg/m <sup>3</sup>
Particulate Matter (PM <sub>2.5</sub> )	24-hr avg	65 µg/m <sup>3</sup>	65 µg/m <sup>3</sup>	---	---
	AAM	15 µg/m <sup>3</sup>	15 µg/m <sup>3</sup>	---	---
Lead (Pb)	Quarterly avg	1.5 µg/m <sup>3</sup>	1.5 µg/m <sup>3</sup>	1.5 µg/m <sup>3</sup>	1.5 µg/m <sup>3</sup>

The CAA Amendments of 1990 established new federal nonattainment classifications, new emission control requirements, and new compliance dates for nonattainment areas. The requirements and compliance dates are based on the severity of nonattainment classification.

CAA Section 176(c), General Conformity, established certain statutory requirements for Federal agencies with proposed federal activities to demonstrate conformity of the proposed activities with each state's implementation plan (SIP) for attainment of the NAAQS. In 1993, the USEPA issued the final rules for determining air quality conformity. Federal activities must not:

- Cause or contribute to any new violation,

- 
- Increase the frequency or severity of any existing violation, or
  - Delay timely attainment of any standard, interim emission reductions, or milestones in conformity to a SIP's purpose of eliminating or reducing the severity and number of NAAQS violations or achieving attainment of NAAQS.

General conformity applies only to nonattainment and maintenance areas. If the emissions from a federal action proposed in a nonattainment area exceed annual thresholds identified in the rule, a conformity determination is required of that action. The thresholds become more restrictive as the severity of the nonattainment status of the region increases.

### **3.3.2 Existing Conditions**

The area generally has clear skies and excellent visibility. A cloud ceiling of less than 3,000 feet above ground level occurs an average of 20 days per year, while visibility less than six miles occurs an average of 22 days per year. Although winds in the region can be strong and gusty in the vicinity of a thunderstorm, typically they are relatively low, averaging 5 mph. The prevailing wind direction is from the west, although southerly winds are common during warmer months.

The atmosphere in the region is generally well mixed. The seasonal and annual average mixing heights can vary from 400 meters in the morning to 4,000 meters in the afternoon. The morning mixing heights are usually low, due to night time heat loss from the ground, which produces surface-based temperature inversions. After sunrise, these inversions quickly break up, and solar heating of the earth's surface results in good vertical mixing in the lower layers of the atmosphere.

Dust is frequently entrained into the atmosphere in this region of the country because of gusty winds and semiarid climate. The Texas Panhandle-southern New Mexico area is considered the worst area in the U.S. for windblown dust, and occasionally the dust is of sufficient quantity to restrict visibility. Most of the seasonal dust storms occur in March and April, when wind speeds are generally higher.

Otero County is currently designated as an attainment area. Baseline emissions in the area are predominantly from vehicular traffic and other human activities. Management crews for Boles Wells Field typically use pickup trucks and other light duty vehicles for transportation on the job, and only occasionally use larger engine equipment such as farm machinery, earth moving equipment, grading equipment, generators, and other heavy equipment.

## **3.4 BIOLOGICAL RESOURCES**

### **3.4.1 Definition of Resource**

Biological resources include native or naturalized plants and animals, and the habitats in which they occur. Although the existence and preservation of biological resources are intrinsically valuable, these resources also provide aesthetic, recreational, and socioeconomic values to

---

society. This section describes plant and animal species or vegetation types that typify the biological resources in the area of Boles Wells Field and focuses on species protected under federal or state law. For purposes of this assessment, sensitive species are plants and animals listed as threatened, endangered, or of concern to the U.S. Fish and Wildlife Service (USFWS), the New Mexico Department of Game and Fish (NMDGF), and the New Mexico Rare Plant Technical Council, which designates state-protected species (see Appendix C).

This section addresses six categories of protection status for species with the potential to occur in the proposed project area. These include: Federal Listed Threatened and Endangered Species; Federal Proposed Species; Candidate Species; State Listed Threatened and Endangered Species; Species of Concern; and State Rare and Sensitive Species.

*Federal Listed Threatened and Endangered Species:* The Endangered Species Act of 1973 (ESA) provides protection to species listed under this category. Endangered species are those species that are in danger of extinction throughout all or a significant portion of their range. Threatened species are those likely to become endangered species in the foreseeable future.

*Federal Proposed Species:* Any species of fish, wildlife, or plant that is proposed in the *Federal Register* to be listed under Section 4 of the ESA.

*Candidate Species:* These are species that the USFWS is considering for listing as federally threatened or endangered but for which a proposed rule has not yet been developed. In this sense, candidates do not benefit from legal protection under the ESA. In some instances, candidate species may be emergency listed if the USFWS determines that the species population is at risk due to a potential or imminent impact. The USFWS encourages federal agencies to consider candidate species in their planning process as they may be listed in the future.

*State Listed Threatened and Endangered Species:* A list of state threatened and endangered species is maintained by the state of New Mexico and these species are protected from harassment, taking, and possession. Similar definitions of threatened and endangered in the federal category apply to the state category. State and federal lists often include the same species.

*Species of Concern:* Species of concern to the USFWS are species for which there is insufficient information to determine if they should be listed. It is an informal term and these species receive no legal protection under the ESA.

*State Rare and Sensitive Species:* New Mexico rare plant species include species with narrow ranges, or occurrences that are more widespread but are numerically rare.

### **3.4.2 Existing Conditions**

A general survey for sensitive species and other biological features was conducted within the Boles Wells Field in June 2004 in support of this EA. Observations from this survey, as well as information compiled from previous study, are included below.

---

### 3.4.2.1 Vegetation

Most of the project area was dominated by a near monoculture of typical Chihuahuan Scrub, such as four-winged saltbush (*Atriplex canescens*), tarbush (*Flourensia cernua*), lotebush (*Ziziphus obtusifolia*), and the occasional western honey mesquite (*Prosopis glandulosa* var. *torreyana*), prickly pear (*Opuntia spp.*), and opportunistic plants in disturbed areas.

State-listed noxious weeds present in the Tularosa Basin, the Alamogordo area and the Boles Wells Field include African rue (*Peganum harmala*) and Russian knapweed (*Acroptilon repens*). Both plants are at risk of spreading with disturbance. Salt Cedar (*Tamarix spp.*) is also common in the region and project area. HAFB, Otero County, and numerous other agencies are partners in an organization established to prevent or minimize the spread of noxious species. HAFB has initiated control efforts, and will continue as funds are made available.

### 3.4.2.2 Wildlife

Evidence of several species of wildlife was observed during the survey, including: Gambel's quail (*Callipepla gambelii*), coyote (*Canis latrans*), collared peccary (*Pecari tajacu*), whiptail lizards (*Cnemidophorus spp.*), sparrows, wrens, flycatchers, turkey vulture (*Cathartes aura*), desert cottontail (*Sylvilagus audubonii*), black-tailed jackrabbit (*Lepus californicus*), and small rodents.

Other observations in this area (Dye, 2004) have resulted in a fairly comprehensive catalogue of known species. The well field has numerous small colonies of bats that forage for insects at the playas and other hydrological features. Porcupines (*Erethizon dorsatum*), mule deer (*Odocoileus hemionus*), several rodents, and the occasional mountain lion (*Felis concolor*) and ringtail (*Bassariscus astutus*) are known to use or occupy the area.

At least 230 bird species have been confirmed at HAFB. Most of these species occupy areas with a greater proportion of riparian or wetland habitat than that found within Boles Wells Field.

Texas horned lizards (*Phrynosoma cornutum*) are known to occur in the Boles Wells Water System Annex in abundance, as are several other herps including: several whiptails (*Cnemidophorus spp.*), rattlesnakes (*Crotalus spp.* and *Sistrurus catenatus*), ground snake (*Sonora semiannulata*), side-blotched lizard (*Uta stansburiana*), desert spiny lizard (*Sceloporus magister*), and short-horned lizard (*Phrynosoma douglasii*).

### 3.4.2.3 Sensitive Species

The USFWS and NMDGF have been contacted for lists of threatened and endangered species in Otero County. No formal surveys for particular species were conducted for this EA, although a general biological survey was performed in order to identify any potential needs for further study.

The Texas horned lizard (*Phrynosoma cornutum*) is typically found in arid and semiarid habitat with sparse vegetation in loose sand or gravel. Potential habitat is present within the project

---

area, and previous surveys indicate that the horned lizard occurs in abundance at Boles Wells Field.

The loggerhead shrike (*Lanius ludovicianus*) is considered a resident at HAFB. It occurs throughout New Mexico at lower and middle elevations. They prefer open country with short vegetation and scattered trees and shrubs, occurring in deserts and prairies in the West and pastures and fields in the East. Previous surveys indicate that loggerhead shrikes occur within the project area.

#### **3.4.2.4 Federally-Listed, Proposed Species, and Species of Concern**

No evidence of federally-listed species or their habitat was noted during the field survey.

#### **3.4.2.5 State-Listed, Proposed Species, and Species of Concern**

No evidence of state-listed species or their habitat was noted during the field survey.

### **3.5 CULTURAL RESOURCES**

#### **3.5.1 Definition of Resource**

Cultural resources are any prehistoric or historic district, site, or building, structure, or object considered important to a culture, subculture, or community for scientific, traditional, religious or other purposes. They include archeological resources (both prehistoric and historic), historic architectural resources, and traditional cultural properties. Only significant cultural resources (as defined in 36 CFR 60.4) are considered for potential adverse impacts from an action. Significant archeological and architectural resources are either eligible for listing or are listed on the National Register of Historic Places (NRHP). Significant traditional cultural properties are typically identified to federal agencies by Native American tribes or other groups, and may be eligible for the NRHP. HAFB does consult with the State Historic Preservation Officer and Tribal Historic Preservation Officers as appropriate to each project proposed by the base.

On 21 November 1999, the DoD promulgated its American Indian and Alaska Native Policy, which emphasizes the importance of respecting and consulting with tribal governments on a government-to-government basis. The Policy requires an assessment, through consultation, of the effect of proposed DoD actions that may have the potential to significantly affect protected tribal resources, tribal rights, and Indian lands before decisions are made by the services. HAFB conducts Native American consultation regarding each project to identify the tribe's concerns.

---

### 3.5.2 Existing Conditions

#### 3.5.2.1 Cultural Resource Background

Archeological evidence reveals that humans have lived in the Tularosa Basin for more than 10,000 years. The initial cultural historical framework for the region was defined by Lehmer (1948) and has been refined by later investigators including MacNeish and Beckett (1987), Whalen (1981, 1994), and Miller (1989, 2001), among others. While some debate exists regarding the likely transition dates between periods and phases and also concerning some aspects of diagnostic material culture, the generally accepted regional chronology is summarized in Table 3-2.

##### *PaleoIndian Period*

The earliest firmly documented occupation of the American continent is called the PaleoIndian Period. It is generally considered to date from about 10,000 to about 6,000 years BCE. The archeological evidence suggests that during this time the earliest Americans were highly nomadic hunters and gatherers. Populations were likely small and dispersed, exploiting a variety of wild food resources but largely focused towards now-extinct megafauna. Archeological sites are typically characterized by distinctive stone spear points, including the widespread Clovis and Folsom styles. Although the PaleoIndian Period has been broadly documented across all of North and South America, archeological evidence is patchy for any location and relatively little is known about this earliest period in southern New Mexico. Isolated projectile points and other diagnostic tool types (Elyea 1988) have been found at widespread locations and a small handful of PaleoIndian sites have been excavated in the region (Carmichael 1983).

TABLE 3-2 REGIONAL CHRONOLOGY

Period	Phase	Approximate Dates
<b>PaleoIndian</b>		<b>10,000 - 6,000 BCE</b>
	<i>Clovis</i>	10,000 – 9,000 BCE
	<i>Folsom</i>	9,000 – 8,500 BCE
	<i>Plano</i>	8,500 – 5,500 BCE
<b>Archaic</b>		<b>6,000 BCE – AD 200</b>
	<i>Early</i>	6,000 – 4,300 BCE
	<i>Middle</i>	4,300 – 900 BCE
	<i>Late</i>	900 BCE – AD 200
<b>Formative</b>		<b>AD 200 - 1400</b>
	<i>Mesilla</i>	AD 200 - 1100
	<i>Doña Ana</i>	AD 1100 -1200
	<i>El Paso</i>	AD 1200 -1400
<b>Protohistoric</b>	-	<b>AD 1400 - 1659</b>
<b>Historic</b>	-	<b>AD 1659 - 1950</b>

---

Despite some evidence of a pre-Clovis occupation, the Clovis Period (*ca.* 10,000-9,000 BCE) is the first firmly documented human occupation in southern New Mexico. The Mockingbird Gap site north of HAFB is the best documented PaleoIndian site in the region. Excavated in the 1960s, this site has yielded the largest assemblage of Clovis period artifacts from southern New Mexico (Weber and Agogino 1997). Folsom Period materials have been reported from HAFB sites and abundant Folsom materials have been found at Lone Butte, 10 miles (16 km) south of HAFB (Amick 1994). Plano period (8,500-6,000 BCE) materials are not common in the area, but have been reported near Orogrande (Seaman et al 1988) and along the Otero Mesa escarpment (Graves et al 1997).

### *Archaic Period*

Near the end of the PaleoIndian Period, global climate began to change slowly, becoming gradually warmer and dryer. In response, plant and animal populations also changed and the human populations began to exploit a wider variety of food resources. Large game was no longer the primary focus of subsistence. Changes in technology included a more diverse suite of lithic tools, increased use of grinding stones and the development of basketry. Pottery is absent. MacNeish and others (MacNeish et al 1993, MacNeish and Beckett 1987) have identified four phases within the Archaic: the Gardner Springs Phase (6,000 to 4300 B.C.), the Keystone Phase (4300 to 2600 B.C.), the Fresnal Phase (2600 to 900 B.C.), and the Hueco Phase (900 B.C. to A.D. 200). Each of these phases is characterized by differences in lithic tool technology and resource exploitation strategies. By the end of the Archaic, many regions have evidence of a slow transition from mobile hunter-gatherers to semi-sedentary horticultural populations. Within the southern New Mexico region, Archaic sites are notably more common than PaleoIndian sites.

### *Formative Period*

During the late Archaic and early Formative Period, distinct regional adaptations began to develop. Horticulture became fully adopted and increasingly supplemented the gathering of wild plant resources. As a result, human populations became larger and more sedentary; settlements (sites) and house structures became larger and more permanent (Stuart and Gauthier 1981). In southern New Mexico, a defining characteristic of the Formative Period is the development of brownware ceramics, with black-on-white decorated pottery appearing after about A.D. 750. Stone tool technology became more diverse and specialized. Trading networks were well developed, as evidenced by Pacific and Gulf coast marine shell, Mexican copper bells, and point-sourced turquoises and obsidians.

Locally, three phases have been defined within the Formative Period: the Mesilla Phase (A.D. 200 to 1100), the Doña Ana Phase (A.D. 1100 to 1200), and the El Paso phase (A.D. 1200 to 1400/1450). Each phase is differentiated and recognized archeologically primarily on the basis of differences in ceramics. A variety of decorated ceramic wares have been well dated, including black-on-whites, black-on-reds, red-on-browns, terracottas, polychromes, and glazes (Stuart and Gauthier 1981).

---

### ***Protohistoric Period***

At the end of the Formative Period, many horticultural villages in the southern New Mexico region were abandoned in response to extended drought. During the early Protohistoric Period, the surviving local populations were sparse and returned to a semi-nomadic subsistence pattern (Upham 1984). Occupation of the Tularosa Basin during the Protohistoric Period is not well understood. Early Spanish explorers reported a variety of cultural groups in the area including the Suma, Manso, Jumano, and Apache (Sale et al 2002: 14). These groups followed a traditional foraging subsistence economy supplemented by limited horticulture and may have been descendants of Puebloan peoples.

It is not clear when the Mescalero Apache entered the region. Spanish records document nomads in the region by 1541 and some scholars have proposed an arrival as early as the 1300s, but this early date is disputed (Hawthorne 1994: 14). Regardless, the Apache were nomadic hunter-gatherers and seasonally ranged into west Texas and northern Mexico. The Apaches traded with pueblos and Spanish villages but also raided these settlements. Spanish incursions into the Tularosa region were effectively limited to occasional salt treks and punitive military expeditions.

### ***Historic Period***

In 1598, Juan de Onate claimed the Rio Grande and all its tributaries for Spain (Hammond and Rey 1966) and for the next two centuries the Spanish colonized and occupied the region. Until 1821, the Tularosa Basin was on the northern frontier of New Spain. When the Treaty of Guadalupe Hidalgo ended the Mexican War in 1848, New Mexico became part of the United States. There is little evidence, however, that Spanish people occupied the Tularosa Basin before it became part of the United States in 1848 (Hawthorne 1994: 15). The Apache effectively discouraged settlement of the Tularosa Basin, and colonists mostly stayed near the Rio Grande.

After 1858, the United States Army actively pursued the Apache and by 1873 were successful in removing them to reservations. The first settlement in the area was in 1862 when several Hispanic families founded the towns of Tularosa and La Luz at the base of the Sacramento Mountains. The settlements were based on subsistence agriculture and sheep and cattle husbandry and survived periodic raids by the Apache (Hawthorne 1994: 16). Beginning in the 1870s, Anglo farmers and ranchers began settling in the area. By the 1880s, subsistence farming, and goat, sheep, and cattle ranching had become the center of the local economy and remained dominant for the next 50 years.

The El Paso and Northeastern Railroad came to the Tularosa Basin in 1898 and spurred rapid development of Alamogordo. Otero County was created the next year from portions of Doña Ana and Lincoln Counties. The U.S. Federal Government began affecting local affairs in 1907 with the creation of the Sacramento National Forest, later renamed the Lincoln National Forest, and in 1933, the National Park Service created White Sands National Monument (Hawthorne 1994: 17). In 1942, the U.S. Army established the Alamogordo Army Air Field and the Alamogordo Bombing and Gunnery Range, which later became HAFB and White Sands Missile Range. Since that time, the military presence has dominated the local economy.

---

### **3.5.2.2 Cultural Resource Inventory**

A search of the Archeological Resource Management System (ARMS) database revealed that 26 archeological sites are located within the Boles Wells Field. Of these 26 sites, six sites (LA 100170, LA 103415, LA 104262, LA 104271, LA 104272, and LA 108111) are located within the Area of Potential Effect (APE). Two of these sites, LA 104262 and LA 104272, had previously been determined to be ineligible for the NRHP and the State Register of Historic Properties and require no further study (USACE July 2004).

From June 9 to June 18, 2004, archeologists from Ecological Communications Corporation (EComm) conducted a Class III inventory of the APE. The pedestrian inventory encountered the six previously recorded sites and also recorded one new site (LA 144440) and 17 isolated occurrences (IOs).

## **3.6 LAND USE**

### **3.6.1 Definition of Resource**

Land use is comprised of natural conditions or human-modified activities occurring at a particular location. Human-modified land-use categories include residential, commercial, industrial, transportation, communications and utilities, agricultural, institutional, recreational, and other developed use areas. Management plans and zoning subdivision regulations determine the type and extent of land use allowable in specific areas and are often intended to promote the land for the benefit of the public health, welfare, and safety or other applicable laws.

### **3.6.2 Existing Conditions**

Boles Wells Field lies within Otero County, New Mexico. Land within the project area is owned and managed by HAFB. Adjacent lands are federally or privately owned, and are used predominately for low density residential subdivisions, footslope and escarpment aesthetics preservation, grazing, and further east, forest management.

## **3.7 AESTHETICS AND NOISE**

### **3.7.1 Definition of Resource**

Aesthetic resources include perceptual attributes that contribute to the quality of the surrounding environment for certain human activities. This EA addresses visual resources and the noise environment.

Visual resources are the natural and manmade features that give a particular environment its aesthetic qualities. In undeveloped areas, landforms, water surfaces, and vegetation are the primary components that characterize a landscape. Manmade elements may also be visible. These may dominate the landscape or be relatively unnoticeable. Both manmade and natural features form the overall impression that an observer receives of an area or its landscape

---

character, and contribute to overall quality of life. Attributes used to describe the visual resource value of an area include landscape character, perceived aesthetic value, and uniqueness.

Noise is considered to be unwanted sound that interferes with normal activities or otherwise diminishes the quality of the environment. It may be intermittent or continuous, steady or impulsive, stationary or transient. There is wide diversity in responses to noise that not only vary according to the type of noise and the characteristics of the sound source, but also according to the sensitivity and expectations of the receptor, time of day, and distance between the noise source and receptor (e.g., a person or animal).

### **3.7.2 Existing Conditions**

The Boles Wells Field security improvement project area is located on the lowest footslopes and basin floor at the western base of the Sacramento Mountains. The area enclosed by the fence is largely undeveloped, with the exception of the vaulted well heads, pipelines, roads, and well field management buildings near the center. Various shrubs, grasses, and trees occupy the area. The fence line itself has been recently scraped with heavy equipment, and portions of the previously-existing fence have been removed. In built areas, plants that are present are mostly those common to disturbed areas. Properties beyond the fence line are primarily used for low-density residential and family business purposes, and are built upon and predominantly fenced or walled. Transportation land uses are highly visible, as U.S. Highway 54 and a Union Pacific railway main line run adjacent to the well field, and the entire vicinity is criss-crossed by roads.

The BLM has designated the footslope and escarpment of the Sacramento Mountains as an Area of Critical Environmental Concern along the west slopes of the mountain range south of Alamogordo and east of Boles Wells. The view from the Alamogordo vicinity is striking, view points along the escarpment overlook the Tularosa Valley, and these BLM lands are managed for visual resource values. Views both to and from the mountains are characterized by the grandeur of large panoramas and natural landscapes.

Noise levels in the proposed project vicinity are primarily residential, agricultural or construction originated, and are typically low, except for the western border of well field. There, U.S. Highway 54 and the Southern Pacific railway parallel one another north-south immediately west of the fence line. There are several noise sensitive locations along the fence line, which are residential developments adjacent to the north and south property lines.

## **3.8 SOLID AND HAZARDOUS WASTE**

### **3.8.1 Definition of Resource**

Solid waste resources include public agencies and private companies that provide licensed facilities for solid waste disposal. They are generally described in terms of their capacity and lifespan for receiving waste. In the context of an EA, the concern with hazardous waste is the potential for an encounter with previously dumped or stored hazardous waste within the project area that would need to be addressed as a result of the proposed project.

---

### **3.8.2 Existing Conditions**

The Otero-Lincoln County Landfill is the New Mexico permitted waste facility designed to dispose of residential, commercial, and construction waste for Otero County and the city of Alamogordo. It is located at mile marker 43 on US Highway 54, approximately 24 miles south of Alamogordo. The landfill first opened in 1994 and has 92 acres permitted for receiving solid waste. Approximately 18-20 acres have been filled; the design anticipates a 50-year life span for operation. The landfill receives an average of 250 tons per day, approximately 72,000 tons per year. Tipping fees for construction waste for HAFB are \$22 per ton (Hammann 2004).

## **3.9 SOCIOECONOMICS**

### **3.9.1 Definition of Resource**

Socioeconomics addresses population, employment, and earnings. The region of influence includes the county in which the proposed project would be located, Otero County, New Mexico.

### **3.9.2 Existing Conditions**

#### **3.9.2.1 Population**

The 2002 population estimate for Otero County is 61,577, a reduction from the 2000 population of 62,298 and increase from the 1990 population of 51,928. The reduction represents the estimated loss of approximately 1.2% from 2000 to 2002. The increased population from 1990 to 2000 represents a gain of approximately 20.0% (US Census 2004).

The 2002 population estimate for the state of New Mexico is 1,855,059, an increase from the 2000 population of 1,819,046. The state of New Mexico population in 1990 numbered approximately 1,514,609. This represents an increase of 20.1% between 1990 and 2000 and 2.0% between 2000 and 2002 (US Census 2004).

#### **3.9.2.2 Employment and Earnings**

There were 27,278 jobs in Otero County in 2000, a decrease of 570 jobs, or 2.0% over the 1995 job total. In 2000, more jobs were found in the private sector than in government or government enterprises. The largest sector was services, with 6,223 jobs (22.8%), followed by state and local government with 4,287 jobs (15.7%) and retail trade with 4,286 jobs (15.7%). Additional employment data over several years is presented in Table 3-3 (BEA 2004).

**TABLE 3-3 FIVE-YEAR EMPLOYMENT COMPARISON FOR OTERO COUNTY**

<i>ITEM</i>	<i>1995</i>	<i>1998</i>	<i>2000</i>
Total Full-Time and Part-Time Employment	27,848	26,870	27,278
Farm Employment	583	590	555
Non Farm Employment	27,265	26,280	26,723
Private Employment	15,736	15,299	16,321
Agricultural services, forestry, fishing, etc.	230	D	D
Mining	37	D	D
Construction	1,608	1,438	1,514
Manufacturing	914	841	872
Transportation and public utilities	1,115	1,125	1,166
Wholesale trade	327	334	332
Retail trade	4,225	4,068	4,286
Finance, insurance, and real estate	1,165	1,511	1,553
Services	6,115	5,689	6,223
Government and Government Enterprises	11,529	10,981	10,402
Federal, civilian	2,214	2,110	2,025
Military	5,485	4,637	4,090
State and local	3,830	4,234	4,287
State government	956	961	993
Local government	2,874	3,273	3,294

D – Not shown to avoid disclosure of confidential information, but the estimates for this item are included in total figures

### 3.10 ENVIRONMENTAL JUSTICE

#### 3.10.1 Definition of Resource

The objectives of EO 12898, *Federal Actions to Address Environmental Justice in Minority Populations and Low-Income Populations*, include identification of disproportionately high and adverse health and environmental effects on minority populations and low-income populations that could be caused by a proposed federal action. Accompanying EO 12898 was a Presidential Transmittal Memorandum that referenced existing federal statutes and regulations, including NEPA, to be used in conjunction with the EO. The CEQ issued *Environmental Justice Guidance Under NEPA* in December 1997. Air Force guidance for implementation of the EO is provided in the Interim Guide Environmental Justice Analysis with the EIAP, dated November 1997. EO 13045, *Protection of Children from Environmental Health Risks and Safety Risks*, requires each federal agency to identify and assess environmental health risks and safety risks that may disproportionately affect children. Agencies must ensure that their policies, programs, and activities address disproportionate environmental, health, or safety risks to children.

Minority populations include all persons identified by the US Census of Population and Housing to be of Hispanic origin, regardless of race, and all persons not of Hispanic origin other than White (i.e., non-Hispanic persons who are Black, American Indian, Eskimo or Aleut, Asian or Pacific Islander, or other race). Low-income populations include persons living below the poverty level as reported in the 2000 Census of Population and Housing. The percentage of low-income persons is calculated as a percentage of all persons for whom the Bureau of the Census determines income status, and is generally a slightly lower number than the total population.

---

### **3.10.2 Existing Conditions**

Based on the 2000 Census of Population and Housing for Otero County, New Mexico, 54.9% (33,806 persons) were minority, and 19.3% were below poverty level. Of the total population, 32.2% were of Hispanic origin, 3.9% were Black, 5.8% were American Indian or Alaska Natives, 1.2% were Asian, 0.1% were native Hawaiian or Other Pacific Islander, 3.6% were of two or more races, and 11.7% reported to be of some other race. Otero County's population in 2000 included 18,165 persons under the age of 18 (29.5%).

---

## **4.0 ENVIRONMENTAL CONSEQUENCES**

Chapter 4.0 presents the environmental consequences of the Proposed Action at HAFB for each of the resource areas discussed in Chapter 3. An environmental consequence or impact is defined as a modification in the existing environment brought about by mission and support activities. Impacts can be beneficial or adverse, a primary result of an action (direct) or a secondary result (indirect), and can be permanent or long-lasting (long-term) or of short duration (short-term). Impacts can vary in degree from a slightly noticeable change to a total change in the environment.

Short-term impacts would occur during and immediately after the construction of the proposed project. For this project, short-term impacts are defined as those tied to the construction phase of the project, whereas long-term impacts are those following completion of the construction phase. Contract specifications would limit construction equipment maneuvering to the existing narrow perimeter road immediately inside the Boles Wells Field property boundary.

Significant impact criteria are presented for each affected resource. These criteria are based on existing regulatory standards, scientific and environmental knowledge, and/or best professional judgment. Potential impacts for this project were classified at one of three levels: significant, insignificant (or negligible), and no impact. Significant impacts (as defined in CEQ guidelines 40 CFR 1500-1508) are effects that are most substantial, and therefore, should receive the greatest attention in the decision-making process. Insignificant impacts would be those impacts that result in changes to the existing environment that could not be easily detected. No-impact actions would not alter the existing environment. In the following discussions, impacts are considered adverse unless identified as beneficial.

### **4.1 SOIL RESOURCES**

#### **4.1.1 Methodology**

The published soil surveys and the updated data tables of soil characteristics provided the descriptive information for the affected environment. The impact analysis is qualitative and is based on the assumption that soil disturbed during excavation is susceptible to wind erosion in this climate any time during the year and to water erosion during precipitation events. Temporary and permanent stabilization of disturbed soils would minimize offsite impacts on air and water resources.

#### **4.1.2 Potential Impacts**

##### **4.1.2.1 Preferred Alternative**

Under the proposed project, approximately 15 acres of ground would be or has already been disturbed as a result of clearing and grading equipment activity in the area. Some erosion control features, such as silt fencing, have already been installed within the project area. Any incorrectly installed controls would be replaced with properly located and constructed features. Additional

---

measures used to minimize or mitigate for wind and water erosion would be described in the SWPPP that would be submitted by the contractor, and approved by USAF, in fulfillment of the USEPA requirements for a Construction General Permit under the NPDES program.

Once minimization and mitigation procedures as outlined in an acceptable SWPPP are followed, and design requirements that allow the spanning of the fence over any drainage are implemented, there would be no long-term significant impacts to soils caused by implementing the Proposed Action.

#### **4.1.2.2 No Action Alternative**

Because no additional soil disturbing activities would occur if the proposed project is not implemented, there would be no impacts under the No Action Alternative.

## **4.2 WATER RESOURCES**

### **4.2.1 Methodology**

The potential for impacts to water resources due to the fence construction would result from surface disturbance during construction and potential water backup and flooding on upstream properties once the fence is in place.

### **4.2.2 Potential Impacts**

#### **4.2.2.1 Preferred Alternative**

Design considerations for the fence have been made to avoid impacts to water flow and quality. At all stream and arroyo crossings at the well field perimeter, construction crews would be instructed to place fence poles on either side of the drainage. Contract language would specify that placing poles directly in any drainage course is not acceptable. This design would allow the fence panel material to span the drainages, thus preventing disruption of flow during rainfall events and the subsequent potential for water to back up onto upstream properties. Poles that have already been installed contradicting this intention would be removed and relocated to a proper upland area. After completion of the proposed action, many of the numerous minor drainages crossing the fence will undoubtedly change course due to natural meander processes, or due to adjacent property owner actions. This will undoubtedly result in some continuing maintenance requirements to keep the movement of surface waters as unaffected as reasonably possible under funding and manpower constraints. Monitoring of, and reacting to, such changing conditions is already a factor in the well field maintenance process, and will be continued.

In compliance with State of New Mexico Ground and Surface Water Quality Protection Regulations (20 NMACE 7.4), any spills that occur during construction must be cleaned up and disposed of properly. The only potential for spills are those of fuel, lubricants, or other fluids from small portable fuel containers, gas-powered augers, generators, heavy equipment, and light-duty vehicles.

---

Under the dictated design and proper execution of erosion control techniques as would be outlined in the SWPPP, no significant short or long-term impacts to water resources would result from the Proposed Action. Additionally, there would be a beneficial impact on existing ground water resources from increased protection and security of the Boles Wells Field area.

#### **4.2.2.2 No Action Alternative**

No surface disturbance would occur as a result of fence construction. Therefore, no impacts to surface water resources would occur. However, enhanced protection of the HAFB underground water supply would not be achieved; thus, the water supply would remain vulnerable.

### **4.3 AIR QUALITY**

#### **4.3.1 Methodology**

The approach to air quality analysis was to estimate the increase in emission levels due to the Proposed Action. Air emissions resulting from the Proposed Action and alternatives were evaluated in accordance with federal, state, and local air pollution standards and regulations. The analysis included assessing potential impacts from ground disturbance activities along the fence line, and emissions from construction equipment and workers commuting to the site. Air quality impacts from a proposed action would be significant if they:

- Increase ambient air pollution concentrations above any NAAQS.
- Contribute to an existing violation of any NAAQS.
- Interfere with or delay timely attainment of NAAQS.
- Impair visibility within any federally mandated PSD Class I area.

According to the New Mexico Air Quality Bureau, actions from the Proposed Action and alternatives would not be regulated under state or federal PSD regulations because they include only fugitive dust and mobile source emissions (NMAQB 2003).

According to USEPA's General Conformity Rule in 40 CFR Part 51, Subpart W, any proposed federal action that has the potential to cause violations, as described above, in a nonattainment or maintenance area must undergo a conformity analysis. A conformity analysis is not required for attainment areas. Because Otero County is designated as an attainment area for all criteria pollutants, a conformity determination would not be required.

#### **4.3.2 Potential Impacts**

Air quality impacts during construction activities related to the Proposed Action would occur from particulate emissions (i.e., fugitive dust) during ground clearing and grading activities and activities and vehicular emissions from construction equipment and workers' vehicles.

---

#### **4.3.2.1 Preferred Alternative**

Air emissions from construction activities under the Preferred Alternative would be similar to those produced during typical light-construction activities. Light-duty and heavy-duty trucks and small generators would be used to haul away waste materials, deliver new fencing materials to specific installation areas, power equipment such as augers, and move soil within the project area. Fugitive dust from equipment travel and activity would also be produced, from movement of small numbers of contractor vehicles during construction activity. Topography and meteorology of the area in which the project is located would not seriously restrict dispersion of the air pollutants.

Any emissions discharged during construction of the proposed project are not expected to cause an increase in local air pollutant concentrations beyond state and federal standards at any time. Only insignificant short-term impacts are expected from the construction phase of the proposed project. No long-term impacts to air resources would be anticipated.

#### **4.3.2.2 No Action Alternative**

Under the No Action Alternative, ground disturbance, non-road combustion, and vehicle commuting would continue unchanged. Air emissions would be identical to those under baseline conditions.

### **4.4 BIOLOGICAL RESOURCES**

#### **4.4.1 Methodology**

Impacts to biological resources would occur primarily from construction activities and the resulting permanent landscape feature. Approximately 1,400 acres of land would be enclosed by a five-foot high chain link fence, which would replace a barbed wire fence. Potential impacts to biological resources were assessed, including both short-term effects of construction activity and long-term effects of the fence on wildlife, vegetation, sensitive ecological features, and sensitive species.

#### **4.4.2 Potential Impacts**

##### **4.4.2.1 Preferred Alternative**

##### ***Upland Vegetation***

Approximately 15 acres of area proposed for this project have been previously cleared of most vegetation, multiple times in the last 50 years. If the project area is to be re-bladed as part of the proposed project, an insignificant number of common shrubs and herbaceous vegetation typical of disturbed areas would be removed. Freshly disturbed areas may encourage the spread of the known noxious weeds on the property (African rue and Russian knapweed). A clear zone of approximately 15 feet would be maintained to allow patrol along the finished fence line.

---

### ***Drainages***

Approximately 24 natural drainages of any appreciable volume, numerous minor rills, and three manmade drainages were noted during a survey. All of the natural drainages are ephemeral, ranging in width and depth from approximately six inches by six inches to six feet by 30 inches. Vegetation at these drainages is similar to that of surrounding uplands, as moisture is retained here for extremely short periods of time and only during precipitation events. There are no wetlands affected by this project.

The manmade drainages are a result of residential developers in the vicinity attempting to control runoff through subdivided areas. At the proposed fence crossing, one major drainage course entering the northwest corner of Boles Wells Field is approximately 45 feet across, and averages 18 inches deep. The vegetation here is dominated by Johnson grass, as well as the only desert willow noted to occur on the entire property (which would be avoided by construction crews). After fanning out somewhat in the northwest corner of Boles, this flow follows a manmade drainage route west, under the railway and U.S. Highway 54, to a borrow pit ephemeral pond in the west edge of the USAF Boles property.

A second manmade ditch deposits runoff onto Boles Wells at Hamilton Road in the middle of the north boundary. This middle ditch has been bladed along the east side of Hamilton Road, and is about six feet wide and three feet deep where it crosses onto USAF property, through culverts under the proposed fence line. Another ditch deposits runoff onto the Boles property at a point about half way between Hamilton Road and the Old El Paso Highway, on the northern boundary fence line. It was originally excavated between lots of a mid/upper-income subdivision, and has subsequently eroded to about five feet deep and eight feet across at the point it crosses the Boles boundary fence line. The flow from these middle and eastern ditches brings runoff and silt onto USAF property, and as the slope of the terrain decreases, all but the most severe runoff is absorbed into the soil of the well field, prompting heavier vegetation growth in those areas.

### ***Wildlife***

Although intensive wildlife surveys were not conducted in preparation of this EA, species composition within the area is generally known from previous surveys and from information provided by area residents. A very insignificant proportion of vegetation would be impacted as a result of the proposed project, as most of the area within the fence line has previously been cleared and graded. There is a potential, however, for impacts to wildlife movement throughout the area. Fencing material would be converted from the currently in place five strand barbed wire fence, that prevents only large livestock, such as cattle, from crossing, to a less passable material of greater height. The upgrade to five-foot chain link fence may hinder the movement of animals such as coyote, porcupine, rabbit, and other small mammals across the property boundaries. In an effort to alleviate this potential effect, the fence would be designed in such a way to preserve the ease of movement on and off the property via the network of drainages that cross in and out of the well field. By allowing the chain link material to span the drainages, wildlife would be afforded ample opportunity to pass through the approximately 25 openings ranging in depth from six inches to approximately 30 inches.

---

### ***Sensitive Species***

Both the Texas Horned Lizard and the Loggerhead Shrike are known to occur in the area. Sandy soils do occur within the project area, which is required by horned lizards for burrowing and hibernating. The defensive mechanism of remaining motionless and attempting to blend into the environment may cause this species to be susceptible to direct mortality and/or injury from movement of construction equipment. Hibernation burrows may also be affected during winter months as a result of ground-breaking activity associated with the proposed project. Loggerhead Shrikes are known to occur in the area, but impacts to populations would be expected to be minimal, if occurring at all. Any individuals present in the proposed project area could temporarily relocate during construction and reoccupy habitat once work is complete.

Short-term impacts may occur to the resources. Both the New Mexico Department of Game and Fish and the U.S. Fish and Wildlife Service have concurred that the Proposed Action is not reasonably expected to cause a significant short or long term impact to biological resources.

#### **4.4.2.2 No Action Alternative**

Under the No Action Alternative, no changes would be made to the existing boundary. Biological conditions within the project area would remain identical to those of the existing conditions, as described in Section 3.4.2.

## **4.5 CULTURAL RESOURCES**

### **4.5.1 Methodology**

Impacts to Cultural Resources from the proposed project and alternatives are assessed by 1) identifying the nature and location of elements of the alternatives; 2) comparing those locations with identified cultural resource locations, areas considered sensitive, and surveyed locations; 3) assessing the known or potential significance of cultural resources; and 4) determining the extent, intensity, and context of the effects. In consultation with the State Historic Preservation Officer (SHPO), a determination is made as to whether the effects would be adverse, and where appropriate, measures are identified to avoid, reduce, or otherwise mitigate those effects.

### **4.5.2 Potential Impacts**

#### **4.5.2.1 Preferred Alternative**

The 17 Isolated Occurrences recorded in the area of affect are not eligible for nomination to the NRHP and so the Preferred Alternative would not result in an adverse effect to these resources.

The proposed action would result in no adverse effect to three sites: LA 100170, LA 104262, and LA 104272. Of these sites, LA 104262 and LA 104272 have been previously determined to be ineligible for inclusion on the NRHP and were not further investigated. Site LA 100170 is an extremely large site with multiple features and has been determined eligible for inclusion on the NRHP. However, it would not be affected by the Proposed Action and no further work is

---

warranted. Should future undertakings adversely affect this site, additional archeological study would be necessary (USACE 2004). Four other sites in the area of affect have been determined eligible for inclusion on the NRHP or are of undetermined eligibility and so must be treated as if they were eligible. Three of the sites (LA 103415, LA 104271, and LA 108111) are sizeable, ranging in area from 17 to 36 acres, while the fourth site (LA 144440) is much smaller and measures approximately one acre in area. All four sites contain redundant archeological deposits in undisturbed portions of the site and the Proposed Action would not adversely affect them. However, these sites should be prominently flagged or fenced during construction of the proposed fence line to contain the construction activities within the 15-foot wide construction corridor (USACE 2004).

#### **4.5.2.2 No Action Alternative**

No additional impacts to cultural resources would result from this alternative.

### **4.6 LAND USE**

#### **4.6.1 Methodology**

Land use impacts can result if an action displaces an existing use or reduces the suitability of an area for its current, designated, or formally planned use. In addition, a proposed activity may be incompatible with local plans and regulations that provide for orderly development to protect the general welfare of the public, or conflict with management objectives of a federal or state agency of an affected area. Land use development would need to comply with federal and state environmental laws and regulations.

#### **4.6.2 Potential Impacts**

##### **4.6.2.1 Preferred Alternative**

Under the proposed project, 33,000 feet of chain link fence would be constructed around Boles Wells Field. Most of the fence would replace an existing fence. Although a survey would be conducted to locate the exact property boundaries, no additional easements or land acquisition would be required for construction of the fence.

The contractor shall contact blue stake and well field maintenance personnel to assure that affects to utility services, underground pipes, etc are avoided. No impacts to surrounding land activities would be anticipated, although illegal trespassing onto the Boles Wells Field would be further restricted. Work would not affect railroad, highway, or other transportation within the area.

Only short-term insignificant impacts would be expected during the construction phase of the Proposed Action. No change in land use would occur, and no long-term impacts are anticipated.

---

#### **4.6.2.2 No Action Alternative**

No impacts or changes to current land use in the area would result from the No Action Alternative.

### **4.7 AESTHETICS AND NOISE**

#### **4.7.1 Methodology**

There are no federal laws specifically protecting visual resources, but federal and state land custodians and local governments are given the power to adopt regulations and procedures to protect resources within their jurisdiction. Local agencies or land developers may enforce standards of high visual value, low tolerance for visible modification, or other designated visual resources classifications. The degree to which an action would modify the existing surroundings is used to assess the level of impact.

Noise impacts are considered qualitatively. The type of noise, noise sources, and duration are described generally. The degree of impact from noise is characterized generally based on the sensitivity of affected areas to noise, and relative changes to the ambient noise environment.

#### **4.7.2 Potential Impacts**

##### **4.7.2.1 Preferred Alternative**

Construction activities for the fence replacement would take place in an area that has previously been cleared and fence has been previously constructed. The new fence would not obstruct views of the Sacramento Mountains, nor would it significantly change the overall landscape and views from the mountain range. Local residents would notice the equipment and personnel movement during construction, and a material distinction after construction is complete, although changes would not be significant, as most of the proposed project area currently has fencing in place, and many of the adjacent properties are fenced in a variety of materials. The new chain link fence would maintain a transparent view from either side of the property line when viewed from near perpendicular angles. At five feet in height, the proposed fence will not extend far, if any, above the majority of the larger vegetation in the vicinity. Only short-term and low level impacts would be expected during the construction phase of the project, and no significant long-term impacts are anticipated.

Noise would be generated by construction activities, although typical equipment to be used would not produce greater noise volumes than the residential construction activities common to the area. Noise would be generated intermittently from the work site during normal working hours until completion. After completion, noise levels would be lower in the project area than in the adjacent neighborhoods. Therefore, only insignificant impacts are anticipated during the construction phase, and no long-term impacts are expected.

---

#### **4.7.2.2 No Action Alternative**

There would be no change in visual resources or ambient noise levels from current conditions under the No Action Alternative.

### **4.8 SOLID AND HAZARDOUS WASTE**

#### **4.8.1 Methodology**

Impacts on solid waste facilities and surrounding areas caused by waste generation and hazardous waste movement are assessed by examining current conditions and anticipating the effect of the proposed project. Reduction in life span of solid waste facilities that would require near-term expansion of capacity (within five years) would potentially be considered a significant impact. In this case, the feasibility of expanding or permitting new areas for receiving solid waste would be examined. Any generation of hazardous waste from the proposed project, or the handling of existing hazardous waste in the project area, would be examined by type of waste, amount of waste, and available options for disposal.

#### **4.8.2 Potential Impacts**

##### **4.8.2.1 Preferred Alternative**

Under the proposed project, approximately 60,000 feet of single strand barbed wire would be removed and disposed of. It is estimated that tightly-rolled waste wire could be compacted to approximately 12 cubic yards and weigh approximately 3,600 pounds. Approximately 1,500 metal T-posts would be removed, and the majority could be donated or sold to local residents for farming and residential projects, as well as used by building supply companies or non-profit construction agencies. What could not be salvaged would be deposited at local waste handling facilities or metal recycling facilities. No hazardous waste would be generated by the proposed fence installation. No short- or long-term impacts are expected from the Proposed Action.

##### **4.8.2.2 No Action Alternative**

No changes would be made under the No Action Alternative.

### **4.9 SOCIOECONOMICS**

#### **4.9.1 Methodology**

Baseline conditions for population, employment, and earnings were analyzed for Otero County, providing statewide comparisons when information was available. Historical data were also collected to be used as a comparison tool against current figures. Data were collected from the U.S. Census Bureau, as well as the Bureau of Economic Analysis.

---

## **4.9.2 Potential Impacts**

### **4.9.2.1 Preferred Alternative**

#### ***Population***

The proposed project would not be expected to create a long-term change in population since jobs associated with fence replacement are expected to be similar to current levels. In addition, construction workers would either reside in the local area or, if hired from outside the local area, would be anticipated to relocate on a temporary basis for the duration of their work.

#### ***Employment and Earnings***

Construction expenditures for the fencing project are projected to approximately \$334,343.48 over a 90-day period in the Fall of 2005. Otero County, by comparison, produced \$44 million of earnings in the construction sector in 1998.

No significant short or long term impacts are expected to socioeconomic resources from the implementation of the Proposed Action.

### **4.9.2.2 No Action Alternative**

No changes would be made to baseline conditions.

## **4.10 ENVIRONMENTAL JUSTICE**

### **4.10.1 Methodology**

Data on minority and low-income populations for Otero County were extracted from data compiled by the 2000 U.S. Census. Total, minority, and low-income populations were described for the county. Other resource impacts identified in the EA were considered to determine the potential for high and adverse health and environmental impacts to human populations. If such impacts were identified, an analysis of the potential for disproportionately high and adverse impacts to minority and low-income populations would be conducted, comparing the demographics of the affected area to those of the entire county.

### **4.10.2 Potential Impacts**

#### **4.10.3.1 Preferred Alternative**

The entire project would be located within land owned by the USAF. Activities at Boles Wells Field and surrounding properties would continue undisrupted by this project. No long-term substantial impacts would be expected to occur.

#### **4.10.3.2 No Action Alternative**

No changes would be made under the No Action Alternative.

---

## 5.0 CUMULATIVE IMPACTS

Cumulative impacts to environmental resources result from incremental effects of a proposed project, when combined with other past, present, and reasonably foreseeable future projects in the area. Cumulative impacts can result from minor, but collectively substantial actions undertaken over a period of time by various agencies (federal, state, and local) or individuals. In accordance with NEPA, a discussion of cumulative impacts resulting from projects that are proposed, under construction, recently completed, or anticipated to be implemented in the near future is required. Any of these other actions that may occur in the area would require NEPA analysis (specific to those proposals) prior to implementation.

A previous fencing project at Boles Wells Field had recently been completed prior to this analysis. Individual wellheads within the property were sealed in concrete vaults and enclosed by 100 x 100 foot fences of 10-foot high chain link. Construction during that project was restricted to small areas of existing disturbance immediately surrounding the wellheads.

One 1300 foot section of chain link fence was recently installed on Air Force property along the Old El Paso Highway right of way, about a mile south of the current Boles Wells project. This fence replaced a deteriorated boundary line fence and was authorized as routine maintenance not requiring an EA, although environmental concerns were considered during the approval process.

A perimeter fencing project similar to, but much smaller than, the proposed project, is currently under informal consideration. It would take place on USAF property across the railroad main line and U.S. Highway 54, west from the currently proposed project area. This separate parcel is a part of the Boles Wells Field property, but it is not in the scope of the currently proposed project and is not discussed in this document.

Other security improvement projects may be proposed for other areas of the BWWSA, as funding may become available. Such projects would be from one to twelve miles distant from the Boles Wells Field, not contiguous, and considerably smaller in scope of area affected. As there is no effective means of predicting when, or if, any such projects will come about, analysis is not included in this current project, although any such analysis would be quite required.

The impacts of the wellhead protection project and potential additional perimeter fencing project are much smaller than, yet similar to, those of the currently proposed project. Many of the wellheads are enclosed within the area proposed to be fenced by the current project. The other possible BWWSA security improvement projects may occur on smaller, geographically separated parcels, and may be reasonably expected to not cause significant degradation of the environment. All are located in essentially similar settings and involve similar construction procedures, equipment and results. The currently proposed project does affect a much larger area, yet the affects are not considered significant. It thus reasonably follows that the cumulative effect of this, and the smaller, geographically separated projects are not considered significant.

---

## 6.0 LIST OF PREPARERS

Bradley Hamer, EComm Hazardous Waste Services Manager  
B.A. in Environmental Science, 1990  
Years of Experience: 14

Jill S. Madden, EComm Natural Resources Program Manager  
B.S. in Wildlife and Fisheries Sciences, 1981  
Years of Experience: 23

Victor Palma, EComm Quality Assurance Officer  
B.S. in Biology, 1980  
M.S. in Aquatic Biology, 1986  
Years of Experience: 24

W. Nicholas Trierweiler, Ph.D., EComm Cultural Resources Program Manager  
B.A. in Anthropology, 1975  
M.A. in Anthropology, 1978  
Ph.D. in Anthropology, 1987  
Years of Experience: 27

Jeremy Walther, EComm Environmental Scientist  
B. S. in Wildlife and Fisheries Science, 2001  
Years of Experience: 4

---

## 7.0 PERSONS AND AGENCIES CONTACTED

Bixler, Glenn. Fort Worth District, U.S. Army Corps of Engineers.

Dye, Jeanne. 49 CES/CEV, Holloman AFB Natural Resources Manager

Gomolak, Andrew R. "JR" 49 CES/CEV, Holloman AFB Historic Properties Manager.

New Mexico Department of Game and Fish

New Mexico State Historic Preservation Officer

U.S. Fish and Wildlife Service, Albuquerque, New Mexico

-----

A copy of the Public Notice which was published in Alamogordo Daily News on April 17, 2005, the Holloman AFB Sunburst on April 22, 2005, and posted on the Commander's Channel on cable TV on April 15, 2005 is included in Appendix D.

---

## 8.0 ACRONYMS

AFI	Air Force Instruction
AFIOH	Air Force Institute for Operational Health
APE	Area of Potential Effect
ARMS	Archeological Resource Management System
ATFP	Anti-Terrorism/Force Protection
BEA	Bureau of Economic Analysis
BLM	Bureau of Land Management
BMP	Best Management Practice
CAA	Clean Air Act
CEQ	Council on Environmental Quality
CFR	Code of Federal Regulations
CO	Carbon monoxide
DoD	Department of Defense
EA	Environmental Assessment
EComm	Ecological Communications Corporation
EIAP	Environmental Impact Analysis Process
EO	Executive Order
ESA	Endangered Species Act
H <sub>2</sub> S	Hydrogen sulfide
HAFB	Holloman Air Force Base
IO	Isolated occurrence
mgd	million gallons per day
µg/m <sup>3</sup>	micrograms per cubic meter
NAAQS	National Ambient Air Quality Standards
NEPA	National Environmental Policy Act
NMAAQs	New Mexico Ambient Air Quality Standards
NMAQB	New Mexico Air Quality Bureau
NMDGF	New Mexico Department of Game and Fish
NMISC	New Mexico Interstate Stream Commission
NO <sub>2</sub>	Nitrogen dioxide
NRCS	Natural Resource Conservation Service
NRHP	National Register of Historic Places
O <sub>3</sub>	Ozone
Pb	Lead
PM <sub>2.5</sub>	Respirable particulate matter less than 2.5 micrometers in diameter
PM <sub>10</sub>	Respirable particulate matter less than 10 micrometers in diameter
ppm	Parts per million
SHPO	State Historic Preservation Officer
SIP	State Implementation Plan
SO <sub>2</sub>	Sulfur dioxide
SWPPP	Storm Water Pollution Prevention Plan
USACE	United States Army Corps of Engineers

---

USAF	United States Air Force
USC	United States Code
USEPA	United States Environmental Protection Agency
USFS	United States Forest Service
USFWS	United States Fish and Wildlife Service

---

## 9.0 REFERENCES

### AFIOH

2004 *Potable Water Vulnerability and Risk Assessment*. Prepared by URS Group Incorporated, Morrisville, North Carolina, for the Air Force Institute of Operational Health

### Amick, D.S.

1994 *Folsom Diet Breadth and Land Use in the American Southwest*. Ph.D. Dissertation, University of New Mexico, Albuquerque.

### BEA (Bureau of Economic Analysis)

2004 *CA25-Total full-time and part-time employment by industry—Otero County, NM*. Regional Economic Information System, U.S. Department of Commerce. [www.bea.gov/regional/reis/](http://www.bea.gov/regional/reis/) [Accessed June 30, 2004].

### Carmichael, D.L.

1983 *Archeological Settlement Patterns in the Southern Tularosa Basin, New Mexico: Alternative Models of Prehistoric Adaptations*. Unpublished Ph.D. dissertation, University of Illinois, Urbana.

### Elyea, J.M.

1988 Analysis of Paleoindian Tools from LA63880. In *Borderstar 85 Survey: Toward an Archeology of Landscapes*. Edited by T.J. Seaman, W.H. Doleman, and R.C. Chapman, pp 231-237. Office of Contract Archeology, Albuquerque.

### Gomolak, Andrew R. "JR"

2004 Real Property Officer, Cultural Resources Program Manager, 49th CES, Holloman AFB. Personal Communication.

### Graves, T, S. Hall, J, Aria, J, Sirianni, and S. Mbutu

1997 *The McGregor Guided Missile Range Survey Project, New Mexico. Volume 2: Otero Mesa Escarpment Survey*. Archeological Technical Report 14, Anthropology Research Center, University of Texas at El Paso.

### Hammann, Mike

2004 Engineer, 49<sup>th</sup> CES, Personal Interview. Otero-Lincoln County Regional Landfill.

### HAFB (Holloman Air Force Base)

1998 *Sensitive Species Management Plans for Holloman Air Force Base, New Mexico*. New Mexico Natural Heritage Program, Department of Biology, University of New Mexico, Albuquerque, New Mexico.

- 
- Hammond, G.P., and A. Rey  
1966 *The Rediscovery of New Mexico, 1580-1594*. University of New Mexico Press, Albuquerque.
- Hawthorne, L.S.  
1994 *Historic Ranch Survey, Holloman Air Force Base, New Mexico*. Unpublished document on file, 49<sup>th</sup> Fighter Wing, Historic Properties Manager, Holloman Air Force Base.
- Lehmer, D.H.  
1948 *The Jornada Branch of the Mogollon*. University of Arizona Social Science Bulletin 17. University of Arizona Press, Tucson.
- MacNeish R.S., G. Cunnar, G. Jessop, and P. Wilner  
1993 *A Summary of the Paleo-Indian Discoveries in Pendejo Cave near Oro Grande, New Mexico*. Annual Report, Andover Foundation for Archeological Research, Andover, Massachusetts.
- MacNeish, R.S., and P.H. Beckett  
1987 *The Archaic Tradition of South-Central New Mexico and Chihuahua, Mexico*. COAS Monograph No. 7. Las Cruces, New Mexico.
- Mendez Albert. Water System Annex Manager, 49 Civil Engineer Squadron, Holloman AFB.  
2004 Personal Communication.
- Miller, M.R.  
1989 *Archeological Excavations at the Gobernadora and Ojassen sites: Doña Ana Phase Settlement in the Western Hueco Bolson, El Paso County, Texas*. Center for Anthropological Research, New Mexico State University, Las Cruces
- Miller, M.R.  
2001 *Post-Pueblo, Protohistoric, and Early Mission Period Archeology in Western Trans-Pecos Texas and Southern New Mexico, AD 1450-1680*. Texas Archeological Society Bulletin 72:105-163.
- NMAQB (New Mexico Air Quality Bureau)  
2003 *Environmental Regulations – Air Quality*. New Mexico Environment Department. <http://www.nmenv.state.nm.us/aqb/regs/index.html> [Accessed July 5, 2004].
- NMISC (New Mexico Interstate Stream Commission)  
2002 *Tularosa Basin and Salt Basin Regional Water Plan, 2000-2040*. South Central Mountain Resource, Conservation and Development Council, Inc. New Mexico Office of State Engineer. <http://www.seo.state.nm.us/water-info/NMWaterPlanning/regions/tularosa/tularosa-menu.html> [Accessed June 21, 2004].

---

NRCS (Natural Resources Conservation Service)

1988 *Soil Survey of Otero Area, New Mexico*. U.S. Department of Agriculture, New Mexico State University Agricultural Experiment Station.

Sale, M., and Lone Mountain's Staff

2002 *Archeological Investigations of 14 Sites at Holloman Air Force Base, New Mexico*. Lone Mountain Archeological Services, Inc., Report No. 519. El Paso.

Seaman, T.J., W.H. Doleman, and R.C. Chapman

1988 *The Borderstar 85 Survey: Toward an Archeology of Landscapes*. Office of Contract Archeology, University of New Mexico, Albuquerque.

Stuart, D.E., and R.P. Gauthier

1981 *Prehistoric New Mexico: Background for Survey*. University of New Mexico Press, Albuquerque

Trierweiler, W. Nicholas, and Robert Swain

2005 *Archeological Survey and Assessment of Damage to Archeological Sites Along the Boles Well Field Perimeter Fence, Holloman Air Force Base, Otero County, New Mexico*. Prepared for the U.S. Army Corps of Engineers, Fort Worth District by Ecological Communications Corporation, Austin, Texas. 51 pp + appendices.

Upham, S.C.

1984 Adaptive Diversity and Southwestern Abandonment. *Journal of Anthropological Research* 40(2):235-256.

USACE (U.S. Army Corps of Engineers)

2004 *Archeological Survey and Assessment of Damage to Archeological Sites Along the Boles Wells Field Perimeter Fence, Holloman AFB, Otero County, New Mexico*. U.S. Army Corps of Engineers, Fort Worth District, Fort Worth, Texas.

USAF (United States Air Force)

1996 *Delineations of Jurisdictional Waters of the United States and Wetlands and Holloman Air Force Base, New Mexico*. U.S. Army Corps of Engineers, Fort Worth District, Fort Worth, Texas.

US Census

May 2004 *State and County Quickfacts*. Population Estimates, 2000 Census of Population and Housing. <http://quickfacts.census.gov/qfd/states/35/35035.html> [Accessed June 22, 2004].

Weber, R.H. and G.A. Agogino

1997 Mockingbird Gap Paleo-Indian Site Excavations, 1967. In *Layers of Time: Papers in Honor of Robert H. Weber*, edited by Meliha S. Duran and David Kirkpatrick, pp 123-127. Papers of the Archeological Society of New Mexico, No. 23. Archeological Society of New Mexico, Santa Fe.

---

Whalen, M.E.

1981 Cultural-Ecological Aspects of Pithouse-to-Pueblo Transition in a Portion of the Southwest. *American Antiquity* 46(1):75-92.

1994 Moving out of the Archaic on the edge of the Southwest. *American Antiquity* 59(4): 622-638.

---

# **APPENDICES**

## **APPENDIX A**

### **SITE PHOTOS**



Photo 1. Typical arroyo under existing barbed wire fence.



Photo 2. View of inside perimeter of well field. Note old bladed area, stabilized berm.

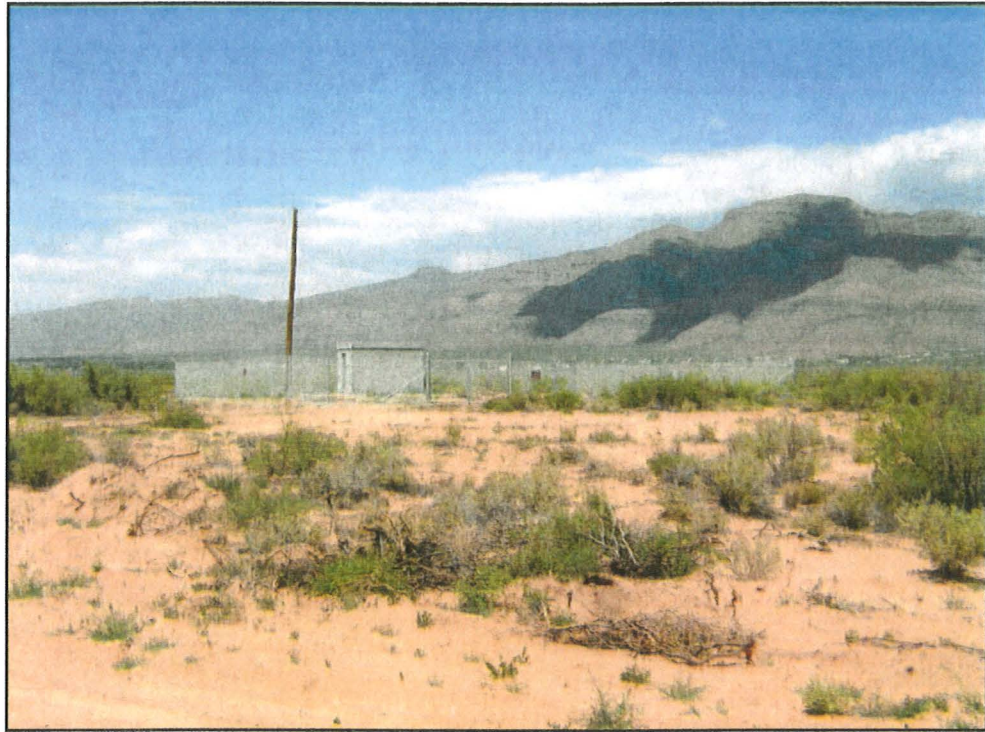

Photo 3. Individual vaulted well head with surrounding barbed wire/chain link fence.



Photo 4. Typical vegetation within project area.



Photo 5. View of artificial drainage (aqueduct) in NW corner of property from east, facing west. The tall band of vegetation is Johnson grass lining the channel.

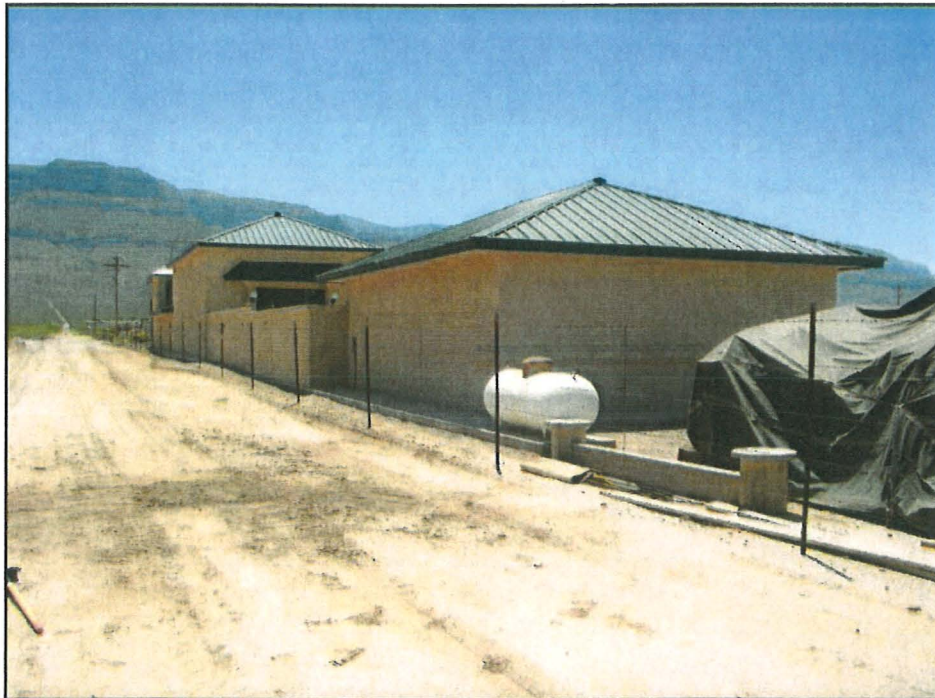
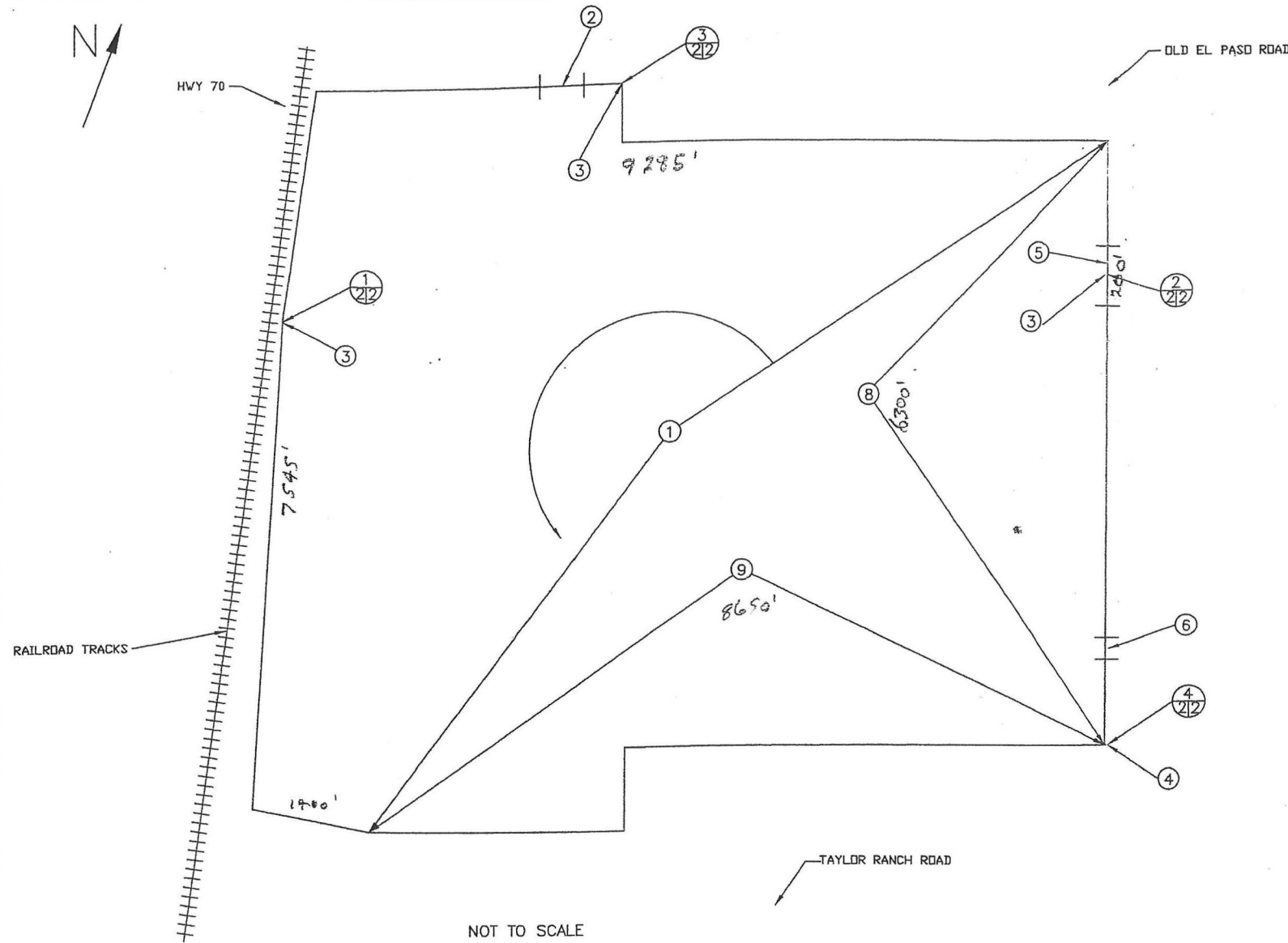

Photo 6. Lightly populated residential area along the southern boundary of Boles Wells Field.

---

**APPENDIX B**  
**ENGINEERING PLANS**



NOT TO SCALE

**GENERAL NOTES:**

① REMOVE BRUSH ALONG FENCELINE AND CLEAR EXISTING DIRT ROADS OF BRUSH. WHERE DIRT ROADS ALONG NEW FENCELINE DO NOT EXIST, CLEAR A 10'-15' PATH ON HAFB SIDE OF FENCELINE.

② FENCE SHALL BE CONSTRUCTED PER THE DETAILS ON SHEET 3.

**KEYED NOTES:**

① INSTALL APPROXIMATELY 18,230 LF OF 5' CHAIN LINK FENCE WITH LINE POSTS EMBEDDED IN CONCRETE AND SPACED 10' O.C.

② 650 LF OF EXISTING PRIVATE FENCE. ENSURE THE GAP BETWEEN NEWLY INSTALLED FENCING TO THE EAST AND WEST OF THIS SEGMENT IS NO MORE THAN 6".

③ INSTALL 15' WIDE MANUALLY OPERATED ROLLING STEEL GATES, SEE DETAILS, SHEET 4.

④ INSTALL 15' WIDE TUBULAR STEEL FRAME SWING GATE (GATE PROVIDED BY 49 CES).

⑤ INSTALL APPROXIMATELY 200 LF OF 5' CHAIN LINK. 100 LF SHALL RUN NORTH OF NEW GATE AND 100 LF SHALL RUN SOUTH. TIE IN TO BARBED WIRE FENCE AT ENDS.

⑥ LOCATED APPROXIMATELY 500 LF NORTH OF SOUTHEAST CORNER, INSTALL NEW T-POST MIDWAY BETWEEN EXISTING STEEL POSTS AND INSTALL BARBED WIRE STRANDS.

⑦ GAP BETWEEN END POST AND CONCRETE APRON SHALL NOT EXCEED 4" (KEYED NOTE LOCATED ON DETAILS 1, 2, AND 3).

**ADDITIVE #1:**

⑧ INSTALL APPROXIMATELY 6,300 LF OF 5' CHAIN LINK FENCE WITH LINE POSTS EMBEDDED IN CONCRETE AND SPACED 10' O.C.

**ADDITIVE #2:**

⑨ INSTALL APPROXIMATELY 8,650 LF OF 5' CHAIN LINK FENCE WITH LINE POSTS EMBEDDED IN CONCRETE AND SPACED 10' O.C.

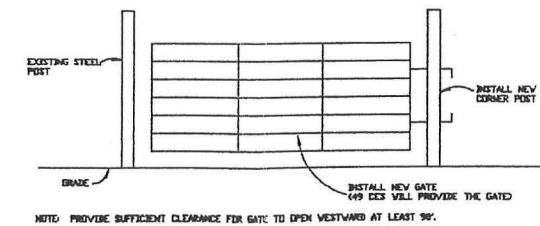

④  
2/2

SOUTHEAST GATE  
N.T.S.

N

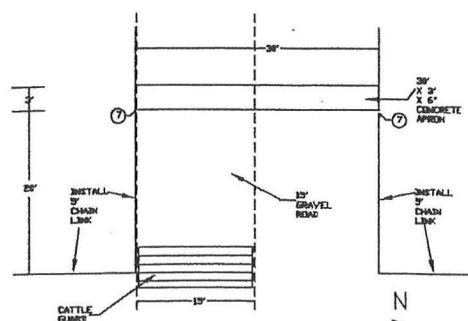

①  
2/2

SITING OF WEST GATE  
N.T.S.

N

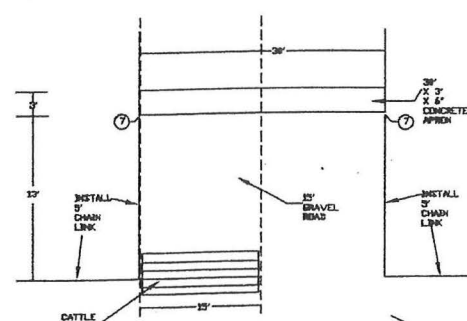

②  
2/2

SITING OF EAST GATE  
N.T.S.

N

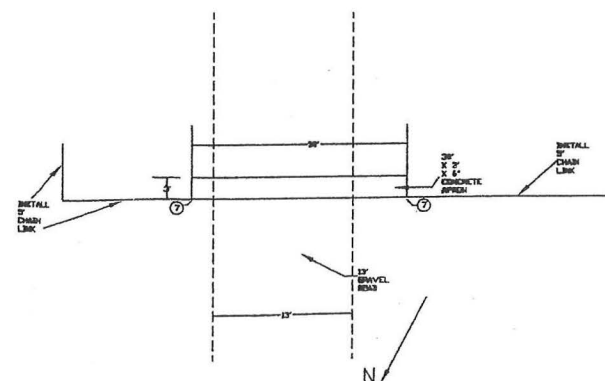

③  
2/2

SITING OF NORTH GATE  
N.T.S.

N

SYMBOL	REVISION	DESCRIPTION	BY	DATE
SHEET TITLE: SITE PLAN				
PROJECT TITLE: REPAIR FENCE, WELL FIELD				
49 CIVIL ENGINEERING SQUADRON HOLLOWMAN AIR FORCE BASE, NEW MEXICO 88330-5000				PLATE
DESIGNED BY: LT. ZETTLER	DRAWN BY: A1C RASING		DATE: MAR 03	
DRAWING FILE NAME/DATE: 80 JUN/ 11		HOL 78--1985 IE	SHEET 2 OF 4	

Mar 03



---

**APPENDIX C**

**THREATENED, ENDANGERED, AND RARE SPECIES INFORMATION**

*New Mexico Game & Fish - Animals in BISON-M***Search on:**

Category = 'All'

County = 'All'

Other Dist = '----HOLLOMAN AIR FORCE BASE'

Current Date: June 7, 2004

Number of Record(s) Found: 5

Records Last Updated on: January 06, 2000

Click on species name to see species report.

**Category: Birds**[Back to top](#)

<a href="#">Loon, Common</a>	<a href="#">Gavia immer</a>
<a href="#">Heron, Tricolored</a>	<a href="#">Egretta tricolor ruficollis (NM)</a>
<a href="#">Osprey</a>	<a href="#">Pandion haliaetus carolinensis (NM)</a>

**Category: Fish**[Back to top](#)

<a href="#">Pupfish, White Sands</a>	<a href="#">Cyprinodon tularosa</a>
--------------------------------------	-------------------------------------

**Category: Mammals**[Back to top](#)

<a href="#">Bat, Spotted</a>	<a href="#">Euderma maculatum</a>
------------------------------	-----------------------------------



The New Mexico Natural Heritage Program is part of the  
 Natural Heritage Network and the Museum of Southwestern  
 Biology, Department of Biology at the University of New  
 Mexico

Last Updated May 13, 2004





**U.S. Fish & Wildlife Service**

**Endangered Species List**

[◀ Back to Start](#)

**List of species by county for New Mexico:**

Counties Selected: Otero

Select one or more counties from the following list to view a county list:

- Bernalillo
- Catron
- Chaves
- Cibola
- Colfax

[View County List](#)

**Otero County**

<u>Common Name</u>	<u>Scientific Name</u>	<u>Listing Status</u>	<u>More Info</u>
bald eagle	<i>Haliaeetus leucocephalus</i>	AD, T	<input type="checkbox"/>
black-footed ferret	<i>Mustela nigripes</i>	E, EXPN	<input type="checkbox"/>
black-tailed prairie dog	<i>Cynomys ludovicianus</i>	C	<input type="checkbox"/>
Kuenzler hedgehog cactus	<i>Echinocereus fendleri var. kuenzleri</i>	E	<input type="checkbox"/>
least tern	<i>Sterna antillarum</i>	E	<input type="checkbox"/>
Mexican spotted owl	<i>Strix occidentalis lucida</i>	T	<input type="checkbox"/>
northern aplomado falcon	<i>Falco femoralis septentrionalis</i>	E	<input type="checkbox"/>
Sacramento Mountains checkerspot Butterfly	<i>Euphydryas anicia cloudercrofti</i>	PE	<input type="checkbox"/>
Sacramento Mountains thistle	<i>Cirsium vinaceum</i>	T	<input type="checkbox"/>
Sacramento prickly poppy	<i>Argemone pleiacantha ssp. pinnatisecta</i>	E	<input type="checkbox"/>
southwestern willow flycatcher	<i>Empidonax traillii extimus</i>	E	<input type="checkbox"/>
Todsens pennyroyal	<i>Hedeoma todsenii</i>	E	<input type="checkbox"/>

---

**APPENDIX D**

**PUBLIC NOTICE**

---

Published in the Alamogordo Daily News, April 17, 2005  
Published in the Holloman AFB Sunburst, April 22, 2005  
Posted on the Commander's Channel on cable TV, April 15, 2005

NOTICE OF AVAILABILITY as of 18 April, 2005  
49<sup>th</sup> Fighter Wing Draft Environmental Assessment  
Boles Wells Field Perimeter Security Project

The 49<sup>th</sup> Fighter Wing proposes to undertake a project to improve the security of the base water supply system. The project would consist of chain link fencing around the perimeter of the Boles Wells Field. The location is at the south end of Hamilton Road, approximately 5 miles south of downtown Alamogordo, NM. This project is bounded by Old El Paso Highway on the East, the Southern Pacific Rail Road and US 54 on the west, a part of Taylor Ranch Road on the south, and would be entirely upon Air Force lands.

Pursuant to the National Environmental Policy Act of 1969, Holloman has prepared a Draft Environmental Assessment and Finding of No Significant Impact analyzing the potential effects of the proposed security improvements, as well as discussing other action alternatives and the no action alternative.

The document will be available on-line at [www.cevp.com](http://www.cevp.com), and available through the 49<sup>th</sup> Fighter Wing Public Affairs Office. Copies for public review will be placed in the Alamogordo Public Library at 920 Oregon Avenue, and the Holloman Base Library in Building 224.

Holloman has scheduled a Public Information Meeting at the Willie Estrada Memorial Civic Center, Wednesday the 4<sup>th</sup> of May, 2005, from 6:30 to 9:00 PM. Doors will open at 6:30, a brief presentation will begin at 7:00, followed by a Public Question and Comment period.

Interested groups and individuals may contact the 49<sup>th</sup> Fighter Wing Public Affairs Office at (505) 572-5406 for more information. Written comments should be submitted by May 18, 2005, to 49 FW/PA, Attn: Boles Security EA, 490 First Street Room 280, Holloman AFB, NM 88330-8287.

---

### **Notice of Availability**

Interested parties are hereby notified that the United States Air Force, Holloman Air Force Base, NM has completed an Environmental Assessment (EA) that resulted in a Finding of No Significant Impact (FONSI) for the Boles Wells Field Perimeter Security Project.

The EA documents the proposed actions for the Boles Wells Field Perimeter Security Project, alternatives to the proposed action, the affected environment, and impacts to the affected environment.

Information regarding the project may be found in the EA and FONSI available for review at the Alamogordo Public Library, Alamogordo, New Mexico. Copies may also be obtained by writing to the address below.

Comments regarding the EA and FONSI may be directed to:

49 FW/PA  
490 First Street, Suite 2800  
Holloman AFB NM 88330-8277

This notice is being issued to interested parties, in accordance with the National Environmental Policy Act (Public Law [PL] 91-190, 42 United States Code 4321 et seq.), as amended in 1975 by PL 94-52 and PL 94-83.

**162 Words**

# AFFIDAVIT OF PUBLICATION

ALAMOGORDO,  
STATE OF NEW MEXICO }  
COUNTY OF OTERO. } SS.

I, RICHARD COLTHARP, being duly sworn, on my oath say that I am the Publisher of the Alamogordo Daily News, a Newspaper of daily circulation, published and printed in the English language at the City of Alamogordo, Otero County, State of New Mexico. That the Alamogordo Daily News has been regularly published and issued for more than nine months prior to the date of the first publication hereinafter mentioned.

That the attached notice was published 1 time in 1 issue of said newspaper, and not in any supplement thereof, the first publication being on December 18, 2005.

That said notice was published in accordance with the laws of the State of New Mexico.

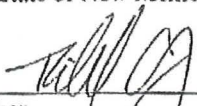
  
\_\_\_\_\_  
Publisher

Subscribed in my presence and sworn before me this the  
22 day of Dec.

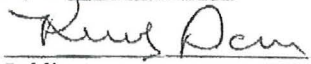
  
\_\_\_\_\_  
Notary Public

My commission expires 2-25-09

Legal #0842

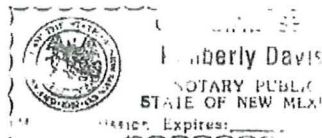

Legal #0842

## Notice of Availability

Interested parties are hereby notified that the United States Air Force, Holloman Air Force Base, NM has completed an Environmental Assessment (EA) that resulted in a Finding of No Significant Impact (FONSI) for the Boles Wells Field Perimeter Security Project.

The EA documents the proposed actions for the Boles Wells Field Perimeter Security Project, alternatives to the proposed action, the affected environment, and impacts to the affected environment.

Information regarding the project may be found in the EA and FONSI available for review at the Alamogordo Public Library, Alamogordo, New Mexico. Copies may also be obtained by writing to the address below.

Comments regarding the EA and FONSI may be directed to:

49 FW/PA  
490 First Street, Suite 2800  
Holloman AFB NM  
88330-8277

This notice is being issued to interested parties, in accordance with the National Environmental Policy Act (Public Law [PL] 91-190, 42 United States Code 4321 et seq.), as amended in 1975 by PL 94-52 and PL 94-83.

---

**APPENDIX E**  
**PUBLIC COMMENTS**

---

## Comment –Response

### Ward Letter, 18 May 2005

1. Grave concerns about the legitimacy and cost effectiveness of the Boles Well Field Perimeter Security Project. *-Noted*
2. Need for correspondence with various project staff, the EA and the Public meeting. *-Noted*
3. Goal: help secure the water source of the base from terrorist act. *-The goal is security improvement.*
4. Fence goal is to aid by reducing trespass. *–As well as providing clear demarcation of the boundary.*
5. Much of the information provided about the project is contradictory or false. *–Opinion noted*
6. Project will not provide enough additional security beyond existing conditions to warrant the expenditure of federal (tax-payer) funds as proposed under the preferred alternative.  
*–Opinion noted. The Vulnerability Assessment performed by security managers indicates the proposed improvement would provide additional security.*
7. Request that the original barbed wire fence be restored with alternative measures that will be equally effective and less costly for detecting intrusion toward the wellhead. *-Noted*
8. Appalled by the original attempt of CEV Engineers to by-pass standard compliance procedures at the onset of this project. *–Opinion Noted*
9. Appalled by the lack of notification to landowners and the physical trespass and damage to private property next to the well field.  
*This Environmental Assessment has included notification. Any trespass and physical damage is part of a process separate from this analysis, as the contractor is required to stay within Air Force property.*
10. Asked to be involved in the preliminary scoping project after Holloman halted the project to conduct NEPA analysis. *–Noted, there is no provision in NEPA nor the CEQ regulations for private citizen participation prior to the Public Meeting.*
11. Requested early (before an EA would be produced) involvement to offer reasonable alternatives before the expense of conducting a formal EA was committed. *–Noted, as above*
12. Request to be involved was denied. *–Interested parties are included in the NEPA process at the Public Meeting stage.*
13. Since that time, two EAs have been developed and the most recent was released for public review. *–Only one EA was developed for this project.*
14. The EA attempts to formalize a botched process and has not succeeded. *–Noted. Level of success is subject to interpretation.*

### Ward and Reiser Letter, 18 May 2005

- 1.a. The tone throughout this document makes it appear that the base took a proactive stance in generating this EA, when in fact Holloman AFB began the project without proper clearances. *–Noted. Changes to Final EA include a more accurate description of the process.*

---

1.b. To be fair to this process and present a more truthful description to the public, this document should state this EA was generated as an afterthought, or at a minimum, is trying to correct a "wrong." *-Noted. Changes to Final EA include a more accurate description of the process.*

2. Why weren't line numbers provided for ease of making comments and referencing? *-Noted*

3.a. Section 1.2: A project specifically for wellhead protection was previously completed sometime in 2002-2003. *-Noted. This project adds to the layered defense of the wells.*

3.b. Each wellhead is protected by a locked concrete block structure constructed over each wellhead and surrounded by a 8 to 10 foot high chain link fence with 3 strands of razor wire on top of the fence, and lighting at the wellheads. *-Noted. This project adds to the layered defense of the wells.*

3.c. Additionally, the office facilities (as stated at the public meeting by Lt. Col. DeMartino) are protected by a high chain link fence and razor wire and lighting. *-Noted. This project adds to the layered defense of the wells.*

3.d. Don't these measures meet the intent of the various directives stated in the 2<sup>nd</sup> paragraph of Section 1.2? *-Noted. This project adds to the layered defense of the wells, in addition to clearly defining the property boundary.*

3.e. If these measures do not meet the directives, why was the wellhead protection project done in the first place? *-Layered defense to meet security improvement objectives.*

3.f. What was the cost of this project? *-This point is being treated as a Freedom of Information Request, beyond the scope of an Environmental Assessment, response will be through other channels. Estimated construction expenditures given in Section 4.9.3.1, page 4-10*

3.g. Was an EA or other environmental assessment completed for the Project? *-Individual wellhead protection projects are in the immediate area of each well, do not extend beyond previously disturbed areas, do not involve affects to the public, and were analyzed as such.*

3.h. This project should be described in its entirety. *-Noted*

3.i. How will a 5 foot chain link fence significantly add to these protection measures? *Delineation, deterrence and delay of intruders is the reasonably expected result.*

3.j. At what cost and waste to tax payers money? *-Opinion of project noted*

3.k. How many documented acts of terrorism occurred before the wellhead protection? *-Project is to prevent future events, not remedy any past.*

3.l. How many documented acts of terrorism occurred since the wellhead protection? *-Project is to prevent future events, not remedy any past.*

3.m. This would provide an indication of the level of vulnerability to the area to terrorism and if this fence should even be constructed.

*-The need to protect water systems is mandated by Congress. The means of doing so is defined by the agency responsible for the water system*

4.a. P1-6, Section 1.3.1: Other issues not addressed include damage to private property along the entire northern boundary of the project area. *-Noted. If damages are documented, compensation would be subject to the Federal claims process.*

---

4.b. Build-up of debris (trash, weeds, etc) against the fence & who would be responsible for cleaning this up, especially should this occur along boundaries with private property? *-Noted. Routine maintenance procedures will include clearing debris.*

4.c. The debris build-up will also impede the movement of water across the area. *-Water currently seeks the path of least resistance, and regularly changes channels in the project area. The proposed security improvement will not significantly affect this natural process.*

4.d. How will this be mitigated for? *-Routine maintenance procedures will include clearing any major build-up of debris.*

4.e. Why weren't County Commissioners notified? *-Commissioner Moore is supportive of this project in his District.*

4.f. This area isn't even within the city limits. *-Noted*

4.g. How will the base control for non-native weeds that may invade the continually disturbed area around the inside perimeter of the proposed fence to prevent spread onto adjacent private lands? *-To the extent possible under program funding and feasibility. HAFB is signatory to an interagency noxious plant management agreement.*

5.a. P.2-1, Section 2.2: The use of the word "dilapidated" is not an objective word. *-Noted*

5.b. A significant portion of the existing barbed-wire fence was not falling apart. *-Opinion noted*

5.c. How many linear feet of the previous barbed-wire fence was truly dilapidated? *-Noted, the extent of the condition is a matter of opinion, the intent of the proposed action is to deter and delay intruders. The proposed new fence would be less penetrable than the existing fence.*

5.d. How many linear feet would have been considered in good condition by most reasonable people? *-Noted. The proposed security improvement project is to deter future events, not remedy the past.*

5.e. Many of the new fence poles exceed 5 feet in height. *-Necessary to provide for wildlife passage and surface water flow under the fence.*

5.f. How will the base ensure that the fence would be constructed at the right height? *-Contract stipulations and inspection.*

6.a. Section 2.2.1: Discrepancies throughout the document on width of clearing around the fence. Please address and clarify. *-Assessment changed to consistently refer to approximately 15 feet in width, limited to the extent of the many previous episodes of perimeter blading which have resulted in a generally substantial berm around the inside limit of the existing disturbance.*

6.b. Since the AF is claiming that because fencing would not be placed within any drainages, even the shallowest of drainage cuts, and thus the issue of impediments to wildlife movement becomes a non-issue. *-Noted*

6.c. Thus, documentation of these claims needs to be provided. *-Noted*

6.d. Provide a map of these identified drainages, along with a frequency distribution of the size of these drainages. *-Noted. The largest natural drainages, and the manmade drainages, generally do not change course because adjacent property owners and/or Otero County maintain those alignments. Those are known quantities and are shown on topographic maps of the area. The smaller drainages naturally change course, count, and location, with each heavy precipitation event. Smaller drainages are also often relocated by the actions of adjacent property owners. Quantification of the small drainages would be invalid within a short time and require constant updating, which is well beyond the scope of this EA.*

- 
- 6.e. Provide the widths & depths of each of these identified points. *-Noted*
- 6.f. How well distributed are these wildlife movement access points? *-Noted, the locations of the smaller access points are expected to be numerous and relatively well distributed along the perimeter, as the microtopography of the perimeter is quite varied. Locations and sizes will change with natural erosion and drainage meander processes as well as adjacent property owner affects.*
- 6.g. What is the AF's definition of "shallowest of drainage cuts?" *-Noted*
- 6.h. How were the drainage cuts identified? *-Noted*
- 6.i. How many of these cuts are large enough to accommodate moderately large animals such as coyotes, badgers, fox, porcupine, raccoon, bobcats?  
*-The smaller drainages are frequent and naturally distributed. The size, location and count of minor drainages is subject to constant change due to natural processes and affects by adjacent land owners. The larger drainages are all man made ditches that empty onto the AF property. All of the man made drainages, and some of the minor drainages allow for passage of small and medium sized animals such as those mentioned.*
- 6.j. In conversation with the Las Cruces Area Office for NM Dept of Game & Fish, mule deer can not easily clear chain link fence greater than 4 to 4.5 feet tall. *-Noted*
- 6.k. Since mule deer occur in the well field, particularly in the wintertime (traveling from the higher bajada slopes to the east of the well field), large sections of the eastern fence line should be limited to 4 feet in height, should the fence even be constructed. Please address this concern. *-Noted. NMDGF and USF&WS concurred that no significant affect are expected to result from this security improvement project.*
- 6.l. And if the AF proposes to maintain a bladed swath, won't all of the arroyos and drainage cuts be continually filled-in preventing movement of wildlife through the fence? *-No*
- 6.m. And if the drainages and arroyos are filled-in, how will water flow unimpeded through the area? -  
*The smaller drainages are frequent and naturally distributed, and are expected to cut new courses across the bladed area. The size, location and count of minor drainages is subject to constant change due to natural processes and affects by adjacent land owners. The larger drainages are all man-made ditches that empty onto the AF property, and will remain as they are.*
- 6.n. The base still has not cleaned out and returned to original contour, a major storm water drainage canal on the west side of our property (at 46 San Pedro Dr.). *-That man-made ditch has been adequately cleared.*
- 6.o. We experience poorer drainage in major rain events, and the canal is slowly back filling with trapped sediments. *-That man-made ditch has been adequately cleared.*
- 6.p. When will the base restore this area, as promised in reply to our 26 Mar 04 letter? *-That man-made ditch has been adequately cleared.*
- 7.a. P. 2-2, Sections 2.3 and 2.5: Who suggested a wooden fence? *-Alternatives are not limited.*
- 7.b. Come on now, how legitimate or reasonable a suggestion was this? *-Opinion of suggestion noted*
- 7.c. What about hog-wire mesh fencing with 12 inch squares as an alternative? This would allow for less impact to wildlife movement and less impact to water flow. *-Noted*

---

7.d. A saner alternative to monitoring the entire perimeter, would have been to consider wireless security cameras installed at each wellhead. Why wasn't this considered? *-This is actually a more expensive alternative which may well be added at a later date, depending upon threat assessments and funding.*

7.e. The wellheads are site of concern. How many documented acts of terrorism have occurred at the wellheads since 9/11/2001? *-Noted. The proposed security improvement project is to deter future events, not remedy the past.*

7.f. How many documented acts of terrorism have occurred at the wellheads since the barbed-wire fence was removed back in the winter of 2004? *-Noted. The project is to improve future security.*

7.g. How is this project a wise expenditure of taxpayers' money? *This question is beyond the scope of an Environmental Assessment, however; the fencing proposal was evaluated as part of a layered defense system proposal, and is considered to provide reasonable security improvement within existing funding.*

7.h. You could probably even get away with installing fake surveillance cameras at the wellhead protection sites. *-Noted*

7.i. The base keeps harping about the need for high security in this remote area, yet, upon returning from home after the public meeting and a late dinner, the Hamilton Road gate into the well field was wide open. And driving past this area, the following morning around 0515 hours, the gate was still open. — *Noted. At the time of this inquiry, portions of the existing fence were down, making the gates a somewhat moot point; however, well field maintenance procedural changes have been made to forestall recurrence of open gates.*

7.j. It doesn't appear to us that this area really needs the nonexistent security provided by a 5 foot fence, but simply that some big wigs at ACC headquarters determined they needed ways to spend Homeland Security money, and any boondoggle project would suffice. *-Opinion noted*

7.k. Why wasn't installing the original barbed-wire fence seriously considered? *-It was considered and rejected as a result of the Water Vulnerability Assessment study.*

7.l. Answers to questions on numbers of terrorism acts in the well field basically amounted to 0, it appears that the barbed-wire fence is doing its job. - *The proposed security improvement project is to prevent future events, not remedy the past.*

8.a. P.2-4, Table 2-1: The table does not address all of the issues, i.e., lack of wildlife movement, debris build-up, poor water movement through the fence and impeded drainage cuts and arroyos, increased likelihood of noxious weeds due to continual disturbances in the bladed areas. *-Opinion noted*

8.b. It is known that non-native, noxious weeds prefer disturbed areas. How will the base ensure non-native weeds do not become established in the disturbed areas? *-As above*

8.c. If not controlled, adjacent private landowners could again become unduly burdened. *-Noted*

8.d. What was the projected cost of implementing each alternative? *-This question is beyond the scope addressed in an EA.*

8.e. How would that compare to video surveillance focused just at the wellhead and office building? *This question is beyond the scope addressed in an EA*

9.a. P. 3-7, Section 3.4: How were the biological surveys conducted in June 2004? *-Pedestrian survey*

---

10. a. P. 3-6-12, Section 3.5: A completely nonsensical write-up. Virtually no relevance to the project, why is this lengthy section even in the EA? *-Standard practice according to the Council on Environmental Quality guidelines.*

11.a. P.4-2, Since the fence is at ground level, except for the "largest" drainages (definition and number unknown), most drainages will likely experience impeded water flow, debris will be caught in the fence (and again who will remove this), *-As in 6.i. above*

11.b. How will wildlife actual move in and out of the area? *-As in 6.i. above*

11.c. Propose that if the preferred alternative goes through, the fence should be constructed a minimum of 12 inches above the drainage cuts and arroyos. Please address this proposition. *-Noted. Not required.*

12.a. P.4-4, Section 4.4.3.1: Finally, a count of drainages and storm-water canals are mentioned, along with range of dimensions. Where is a map of these drainages? *-Noted The largest natural drainages, and the manmade drainages, generally do not change course because adjacent property owners and/or Otero County maintain those alignments. Those are known quantities and are shown on topographic maps of the area. The smaller drainages naturally change course, count, and location, with each heavy precipitation event. Smaller drainages are also often relocated by the actions of adjacent property owners. Quantification of the small drainages would be invalid within a short time and require constant updating, which is well beyond the scope of this EA.*

12.c. Where is a table showing the frequency by some size/volume categories? *-Noted, see 12.a.*

13.a. P. 4.4, Wildlife section: other animals that would be affected include Gambel's and Scaled Quail and roadrunners, particularly young. Adults themselves are poor fliers, and would be impeded to some degree by chain link fences. *-Noted*

13.b. The fence, if constructed, should probably be raised approximately 12 inches above the drainage and other canals to ensure better wildlife movement and flow of storm water. *-Noted*

14.a. P. 5-1, Section 5.0: There are cumulative impacts associated with this project. *-Noted*

14.b. We have requested the NEPA documentation on the chain-link fencing project that occurred on the Douglas Well-field area over a year ago and still have not received any information. Why not? *-That project replaced a short section of road side barbed wire boundary fence, which was being crossed by unauthorized parties. Analysis of that proposal found that the replacement of that linear section of fence was routine maintenance in a previously disturbed area, and did not require further environmental analysis.*

14.c. We once again request a copy of the EA for the Douglas Well-field project. *-Noted*

14.d. Since these projects were in close proximity to each other and had the same intended result, it appears that the base disconnected the projects to avoid potential cumulative impacts to the entire area. *-Noted. These projects are geographically separated.*

14.e It is our understanding that this can be considered a violation of NEPA. *-Opinion noted*

14.f. With an even greater area of wildlife habitat being potentially affected by these two fencing projects, how are you ensuring negative impacts are not occurring? *-Noted, the projects are separate in both time and space.*

14.g. What monitoring is occurring at the Douglas Well-field to address any impacts to wildlife? *-Noted*

---

14.h. What was the baseline data to determine what changes may be occurring to population levels or distribution of species or overall biodiversity in the area? *-Noted. Beyond the scope appropriate to the scale of this proposed security improvement project.*

14.i. What would be the baseline date for the Boles Well Field area? *-Noted.*

14.j. What monitoring would be conducted in the Boles Well-field to ensure that the fence is not having negative impacts to wildlife movements, animal species distribution or overall biodiversity? *-Noted. These suggested studies, while potentially interesting, are beyond the scale appropriate to this project. We accept the guidance obtained by consultation with NMDG&F and USF&WS that no significant adverse affects are reasonably expected.*

14.k. We would like to review any monitoring plans developed for these two areas. *-No plans are required beyond those already set down in the HAFB Integrated Natural Resources Management Plan.*

15.a. What have been the costs associated with this project, to include the following: *-Noted. Totals will not be available until all facets of the project are completed.*

15.b. Estimated cost of fence construction itself? *-see Section 4.9.3.1 page 4.10*

15.c. Cost of any penalties? *-No penalties assessed.*

15.d. Potential costs associated with damages that occurred on private property? *-Unknown pending receipt and negotiation of any such claims.*

15.e. Costs associated with the NEPA process (surveys, etc) and development of this EA through the final version? *-Noted. Costs will include an Archaeological Survey and Damage Assessment, public interaction, EA production and distribution expenses.*

15.f. Maintenance costs associated with a chain link fence? *-Noted. Minimal unless damaged.*

15.g. Monitoring costs to ensure that there are no environmental consequences to the proposed alternative? *-None beyond those defined in the HAFB Integrated Natural Resources Management Plan.*

15.h. What was the cost of each alternative that was discarded from further consideration? *-Noted. Actual costs of alternatives are not required for Environmental Assessment purposes*

15.i. What would be an estimated cost of alternatives suggested? *-Security improvement is the purpose, cost is one factor. These questions are beyond the scope of the EA process.*

16.a. Appendix B, Engineering Plan: The site plan map states this was a fence repair project from March 2003. *-Noted*

16.b. When did the base change the project from repairing the existing barbed-wire fence to trying to put in a chain link fence? *-After the Vulnerability Assessment.*

16.c. Who specifically authorized the work to proceed on the chain link fence without an EA being conducted? *-Noted. This is beyond the scope of an Environmental Assessment.*

16.d. What procedures have been implemented at Holloman AFB to ensure these oversights do not occur again? *-Changes to the work order generation and review process, and personnel changes have been made to improve the review and scheduling of proposed projects.*

---

### Marks Letter, May 2005

1. The project is a waste of taxpayers dollars, a five foot fence will not slow down anyone intent on accessing the well field. *–Opinion noted. Project is part of a layered approach to security improvement, to delineate, deter and delay trespass.*
2. President Bush said we would go after Terrorists where they live, not cower behind fences here at home. *–Noted. Comment is beyond the scope of this Environmental Assessment.*
3. If a terrorist wanted to contaminate the water system, he could access the aquifer in my back yard or any other well located to the northeast, from the northeast corner of the project area. *–Noted*
- 4.a. The existing barbed wire fence has been adequate for almost 15 years. To date, the only serious trespass violation, told to me by Col. DeMartino, has been someone shooting at electrical transformers. That could be accomplished without setting foot on the property. *–Noted. Project is to prevent future events, not remedy the past.*
- 4.b. A large section of the fence on the north boundary has been missing for almost a year, No Trespassers? *–Noted. –Project is to prevent future events, not remedy the past.*
5. Wildlife movements would be seriously affected, we enjoy having coyotes cross our property and keeping the rabbit population under control. *–Noted*
6. The new eight foot fences with barbed wire around the top and concrete bunkers are adequate and by using inexpensive modern technology, i.e., remote sensors, motion detectors, silent alarms, the wells could be sufficiently protected. *–Noted. Additional layers of defense may be considered in the future. The technology may be relatively inexpensive, but the support, maintenance and manning of sensor systems is not inexpensive.*
7. After renting a home nearby for three years, my Wife and I purchased the lot at 163 Old El Paso Hwy. We chose this lot for the fantastic view. I built my idea of the American Dream from the ground up, totally with my own hands! An all steel home! A five foot chain link fence, less than 200 feet from my front porch, at eye level would seriously lower the value of our home. *–Opinion noted*
- 8.a. Last but not least, the money involved would be better spent on our southern border. *–Beyond the scope of this Environmental Assessment.*
- 8.b. Open your eyes! We are being invaded by illegal aliens! *–Beyond the scope of this Environmental Assessment.*
- 8.c. President Fox of Mexico is dumping his countries human waste on the U.S., seriously affecting our economy. Our hospitals are going broke because they have to provide care, our schools are going broke because they have to provide education to illegal aliens. 29% of people in our prison system are illegal aliens. *–Noted. Beyond the scope of this EA.*

### Francis and Lucile DeLage Comments May 2005

1. In my opinion, the fence should be built. Any deterrent to slow someone bent on destruction should be taken to help protect our people on the base. *–Noted*
2. I was present at the public meeting and it seems to me anyone who would buy property across from a military installation should expect a fence to be built. *–Noted*
3. The Doctor environmentalists who were present were just trying to make the Air Force spend the money on useless studies to drain off enough money so the Air Force would not build the fence. *–Noted*

---

#### Joseph Preston Comments May 2005

1. As a resident on San Pedro Drive with a residence bordering the proposed fence line, I would like to state that I have no objections to a fence, what-so-ever. If Air Force engineers have concluded that a fence proposal is the best means of securing the water supply for the base then I whole heartily agree. -Noted

#### Gary Kite Comments 6 May 2005

1. Thank you for the informative Boles Wells EA public meeting given on 4 May. We are whole-heartedly in favor of the project in order to prohibit trespassing on government property. We share a southern 660 feet of property line with this well field. Please feel free to start fencing at this southern border. -Noted
2. Additionally, in your EA section 4.8.3.1, you state the existing metal T-posts would be removed and donated or sold. We would be very interested in obtaining a portion of these metal T-posts for use in fencing projects on our property. -Noted

#### Unsigned Comment Sheet from Public Meeting May 2005

1. Just a quick comment to say that this meeting was handled quite professionally and Mr. DeMartino's management and responses to some of the heated comments was excellent. Good job, these types of meetings are never easy. -Noted

#### New Mexico Environment Department Comments 5 May 2005

##### Surface Water Quality

1. A Storm Water Pollution Prevention Plan (SWPPP) is required for this project. -Noted. A SWPPP will be prepared.
2. Both the contractor and the government will need to obtain permit coverage under the National Pollutant Discharge Elimination System (NPDES) General Permit for Discharge from Large and Small Construction Activities. -Noted. NPDES process will be followed.

##### Ground Water Quality

1. The project is unlikely to have any adverse affect on ground water quality. -Noted
2. Any spills of fuel or machinery lubricants during construction of the fence must be cleaned up and disposed of properly. -Noted. Will be accomplished as necessary.

##### Hazardous Waste

1. The NMED concern is the potential for encounter with previously dumped, abandoned, or discarded containers/receptacles of hazardous waste at the project site. -Noted
2. Discovery of discarded hazardous waste must be reported to NMED orally within 24 hours from the time Holloman becomes aware of the circumstances. -Noted. Will be accomplished as necessary.
3. Holloman shall implement corrective action for any findings of hazardous waste and/or hazardous waste constituents found at the proposed project site as necessary, to protect human health and the environment. -Noted. To be accomplished as necessary.

---

**State of New Mexico Department of Game and Fish Comments 27 May 2005**

1. NMGF No. 10054
2. In response to your letter dated 15 Apr 2005 regarding the above referenced project, the Department of Game and Fish does not anticipate significant impacts to wildlife or sensitive habitats. *-Noted*
3. For your information, we have enclosed a list of sensitive, threatened and endangered species that occur in Otero County. *-Noted*
4. Thank you for the opportunity to review and comment on your project. *-Noted*

**U.S. Department of Interior Fish and Wildlife Service Comments 23 May 2005**

1. Based on our review of the EA, the proposed project should result in minimal impacts to fish and wildlife resources. *-Noted*
2. However, to ensure that construction related migratory bird impacts are avoided, we recommend that construction activities occur outside the general migratory bird nesting season of March through August. *-Noted*
3. Areas proposed for construction during the nesting season be surveyed, and when occupied, avoided until nesting is complete. *-Noted*
4. We also recommend that the minimization measures identified on pages 2-1, 2-2, 4-1, 4-2, 4-5 and 4-6 of the EA be implemented. *-Noted*
5. In future correspondence regarding this project, please refer to consultation # 2-22-05-I-383. *-Noted*