

15662 RC



Human-in-the-loop Simulation-based Combat Vehicle Duty Cycle Measurement: Duty Cycle Experiment 1 (06S-SIW-080)

Victor J. Paul
U.S. Army TARDEC-GVSL
April 4-5, 2006



Report Documentation Page

*Form Approved
OMB No. 0704-0188*

Public reporting burden for the collection of information is estimated to average 1 hour per response, including the time for reviewing instructions, searching existing data sources, gathering and maintaining the data needed, and completing and reviewing the collection of information. Send comments regarding this burden estimate or any other aspect of this collection of information, including suggestions for reducing this burden, to Washington Headquarters Services, Directorate for Information Operations and Reports, 1215 Jefferson Davis Highway, Suite 1204, Arlington VA 22202-4302. Respondents should be aware that notwithstanding any other provision of law, no person shall be subject to a penalty for failing to comply with a collection of information if it does not display a currently valid OMB control number.

1. REPORT DATE 27 MAR 2006	2. REPORT TYPE Briefing Charts	3. DATES COVERED 27-03-2006 to 27-03-2006			
4. TITLE AND SUBTITLE HUMAN-IN-THE-LOOP SIMULATION-BASED COMBAT VEHICLE DUTY CYCLE MEASUREMENT: DUTY CYCLE EXPERIMENT 1 (06S-SIW-080)		5a. CONTRACT NUMBER			
		5b. GRANT NUMBER			
		5c. PROGRAM ELEMENT NUMBER			
6. AUTHOR(S) Victor Paul		5d. PROJECT NUMBER			
		5e. TASK NUMBER			
		5f. WORK UNIT NUMBER			
7. PERFORMING ORGANIZATION NAME(S) AND ADDRESS(ES) U.S. Army TARDEC ,6501 E.11 Mile Rd,Warren,MI,48397-5000		8. PERFORMING ORGANIZATION REPORT NUMBER #15662			
9. SPONSORING/MONITORING AGENCY NAME(S) AND ADDRESS(ES) U.S. Army TARDEC, 6501 E.11 Mile Rd, Warren, MI, 48397-5000		10. SPONSOR/MONITOR'S ACRONYM(S) TARDEC			
		11. SPONSOR/MONITOR'S REPORT NUMBER(S) #15662			
12. DISTRIBUTION/AVAILABILITY STATEMENT Approved for public release; distribution unlimited					
13. SUPPLEMENTARY NOTES SPRING SIW CONFERENCE, HUNTSVILLE, AL 2006					
14. ABSTRACT N/A					
15. SUBJECT TERMS					
16. SECURITY CLASSIFICATION OF:			17. LIMITATION OF ABSTRACT Same as Report (SAR)	18. NUMBER OF PAGES 25	19a. NAME OF RESPONSIBLE PERSON
a. REPORT unclassified	b. ABSTRACT unclassified	c. THIS PAGE unclassified			



2006 Spring SIW

Outline

- Duty Cycle Experiments
- Simulation Objectives
- Simulation Design
- Experiment Design
- Results
- Conclusions

Duty Cycle Experiments

- TARDEC has a Power & Energy program to develop future vehicle power systems.
- Design requires understanding of use.
- To measure use, vehicle must exist.
- Duty cycle experiments use simulation to measure duty cycles of notional vehicles.
- Duty cycle captures:
 - Operator (driver/gunner) use
 - External events

Simulation Objectives

- Create motion based simulation to invoke realistic driving behaviors
- Measure power usage of modeled vehicle during simulated battle
 - Mobility Loads
 - Non-Mobility Loads
- Move towards hardware-in-the-loop experiment

Simulation Design: Top Level

- 6 Major Components
- 12 Computers
- Communications
 - Ethernet
 - SCRAMNet
- Performance:
 - Model update: 500 Hz
 - System Latency: 247 ms

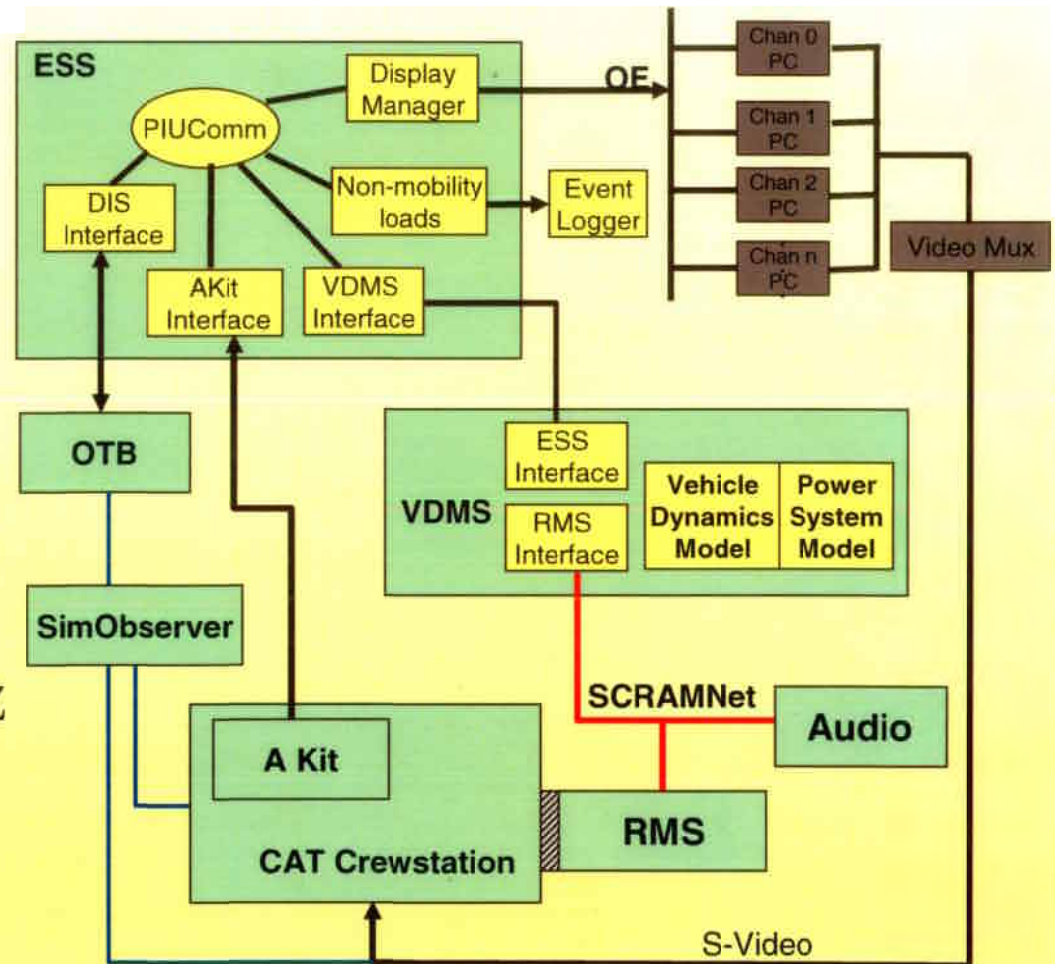



2006 Spring SIW

Simulation Design: RMS

Platform Payload	1,600 lbs.
Platform Diameter	46 inches
Acceleration Bandwidth	40 Hz
Axes Displacement	
Linear (vert., lat., long.)	± 20 in.
Angular (roll, pitch, yaw)	± 20 °
Axes Velocity	
Linear (vert., lat., long.)	± 50 in./s
Angular (roll, pitch, yaw)	± 70 °/s
Axes Acceleration	
Linear (vert., lat., long.)	± 2 g's
Angular (roll, pitch, yaw)	± 1150 °/s ²



Applications

Man-in-the-loop simulation

- Human/Robotic Investigations
- Crew station design
- HLA exercises/war-gaming

Crew station and component development

- Seat characterization
- Hardware component testing

Motion Drive

- Washout Algorithms
- Real-time Vehicle Dynamics
- Control Loaders
- Function Generator
- Random Signal Generator

Data Acquisition

- Soldier Performance
- Vehicle Performance
- HLA Battlefield Scenarios
- Simulator Performance

06S-SIW-080

Simulation Design: CAT Crewstation

- Research tool for future crewstations
- 3 touch screens
 - 6 virtual displays
- Multi-function
- Soft button + hard button
- Yoke + Pedals
- “Drive” function





2006 Spring SIW

Simulation Design: ESS

- Provided with CAT
 - Training
 - Mission Rehearsal
- Used as DCE IG
- Based on open architecture
- Interfaces to OTB
- “Mobility” process replaced with VDMS

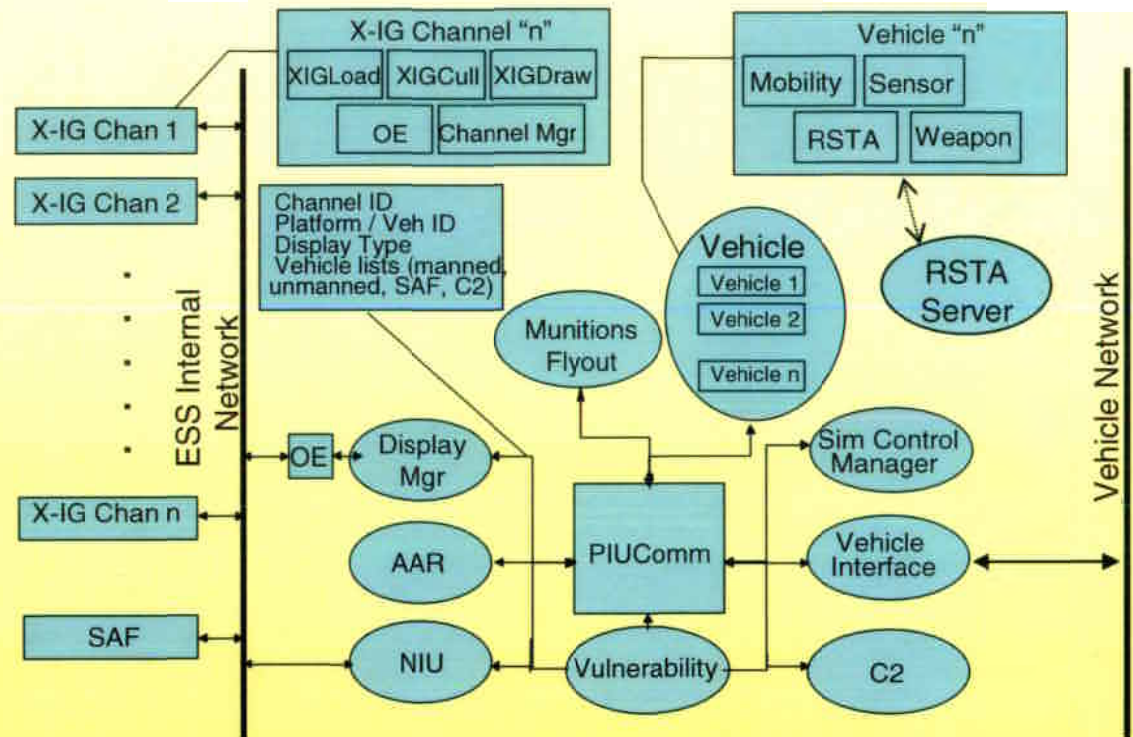

Simulation Design: VDMS

- VDMS is a process:
 - Real-time Dynamics
 - Power Train
 - Terrain Model
 - Interfaces to external systems.
- Deliver dynamic models in executable form.
- Can be used to simulate unmanned or manned vehicles.

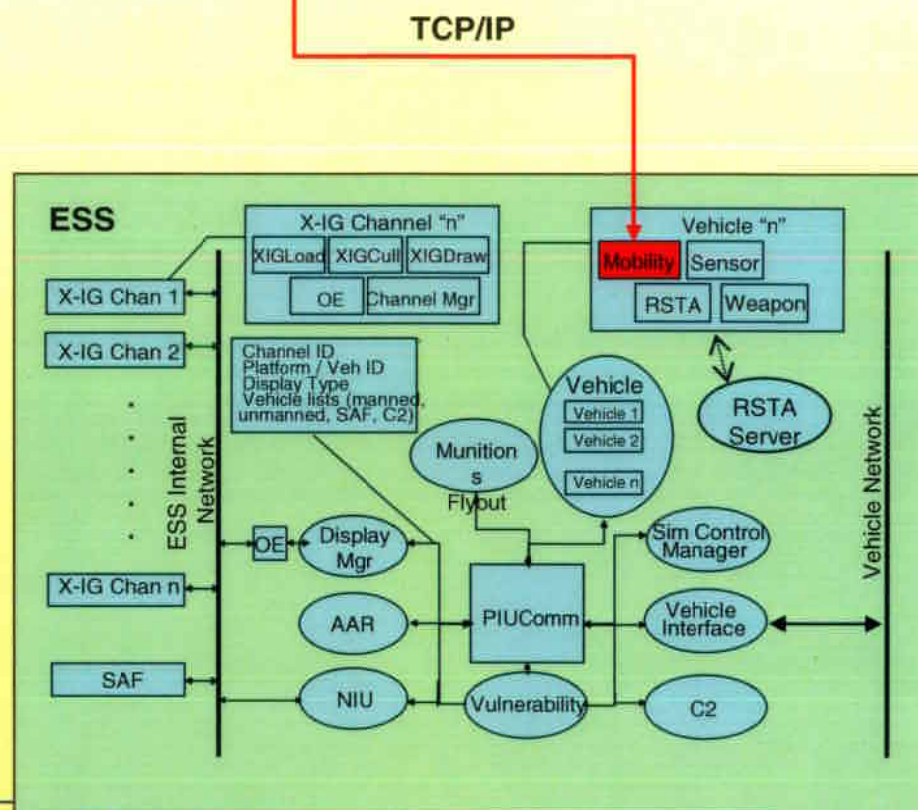
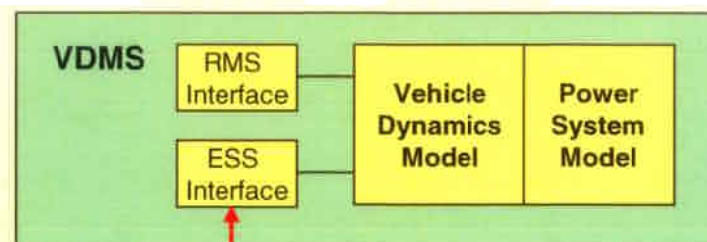

Simulation Design: Vehicle Dynamics

- 24T Tracked Vehicle (MCS)
- Front-drive
- 6 road wheels/side
- SimCreator®'s Multi-body Dynamics
- Executes in VDMS
- Interfaces to Power System

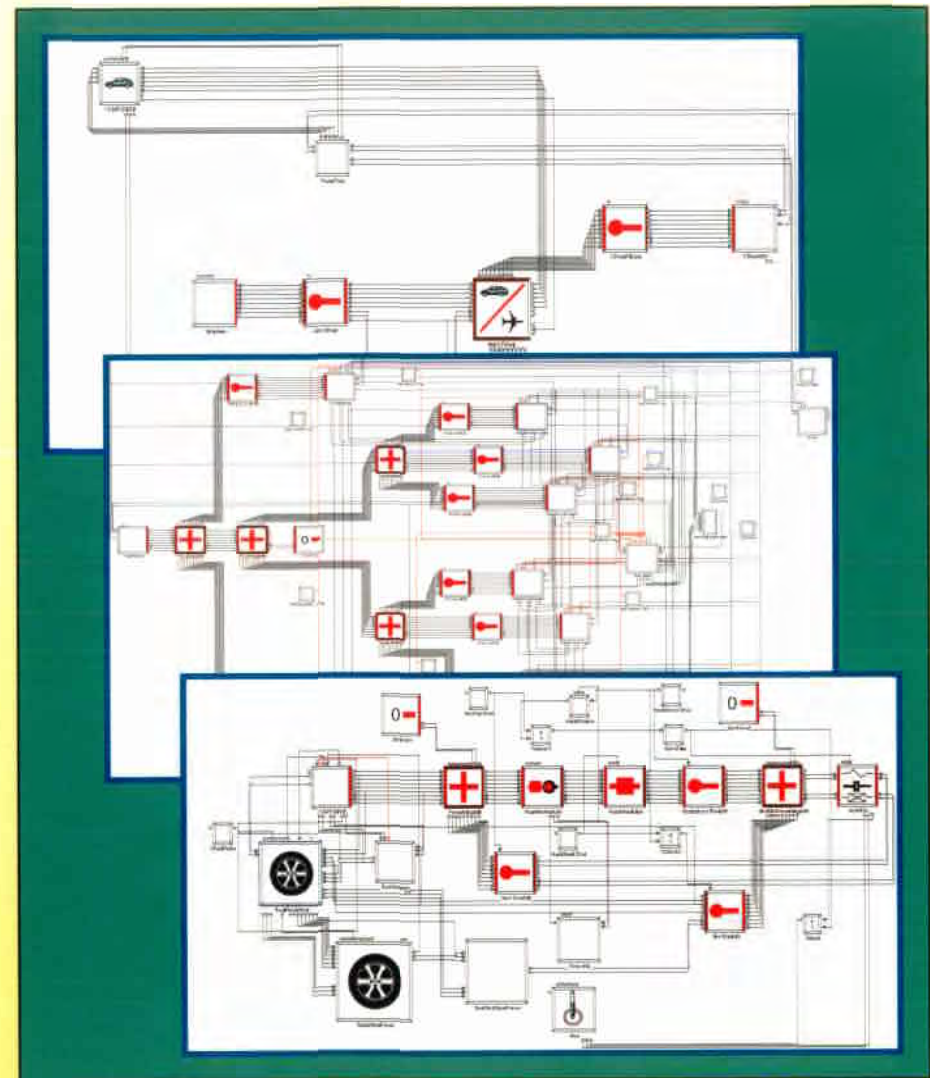

Simulation Design: Power System

- Series Hybrid Power System for MCS
- Independent Left/Right
- Diesel Engine/Generator
- 600 V bus w/Battery
- Two 300kW traction motors.
- Includes thermal model
- Implemented in Simulink w/ Real-time workshop

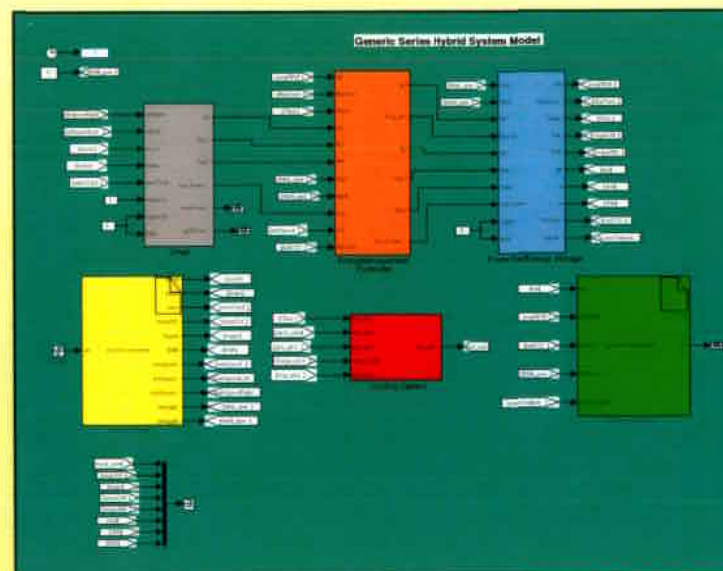
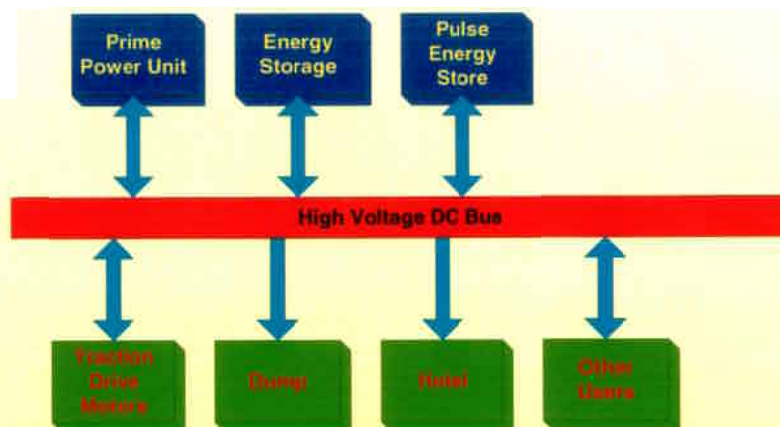

Simulation Design: Audio System

- Internal sounds
 - Engine
 - Track
 - Engine RPM & vehicle speed change sound
- External sounds
 - Battle noise
 - Bullet Pings

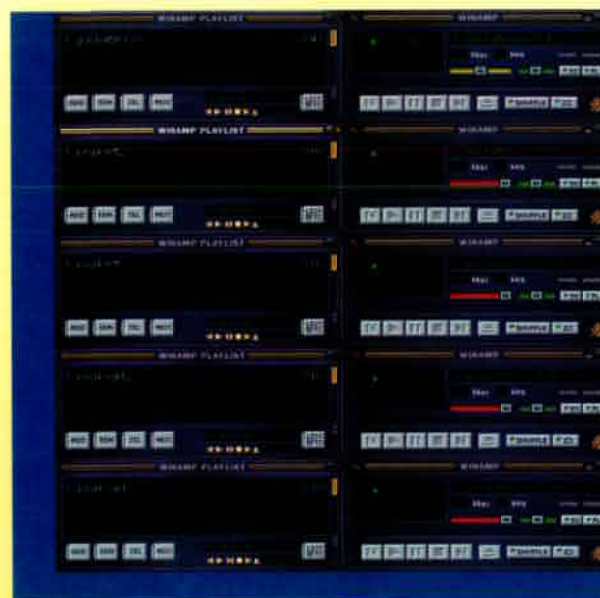
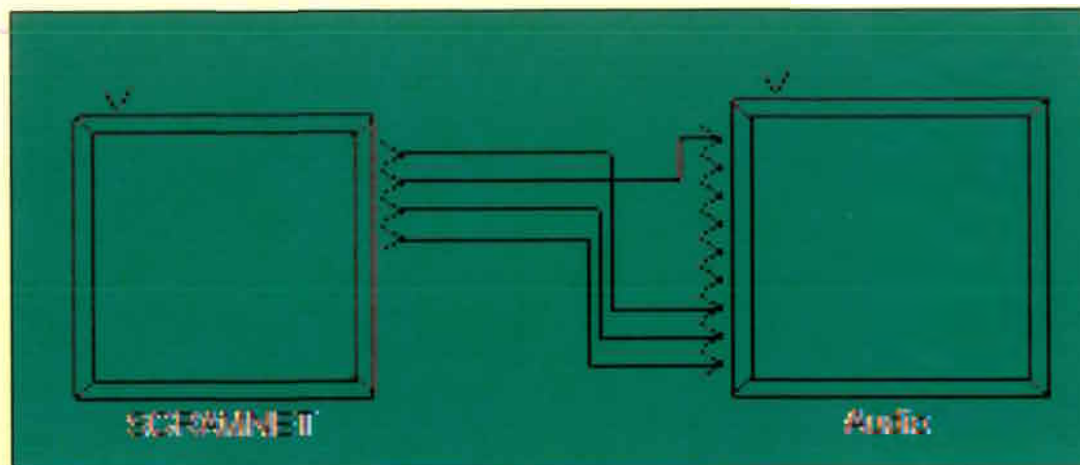

Experiment Design: Two Experiments

- DCE1

- Formal Study
- Battle scenario
- 9 civilian subjects

- DCE1.1

- Informal follow-on
- Driving scenario
- 7 civilian subjects

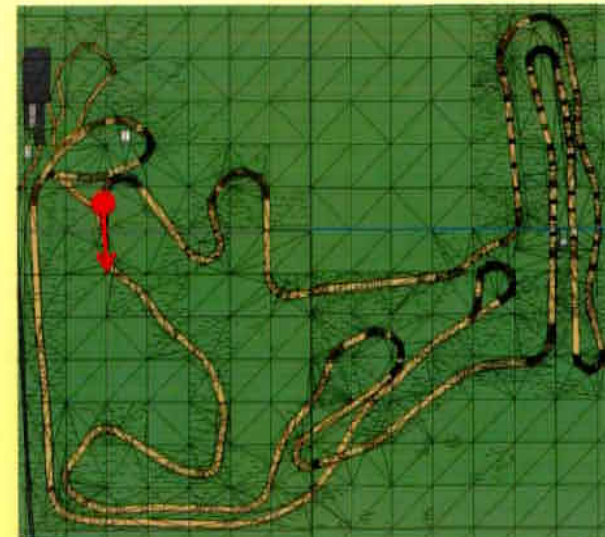
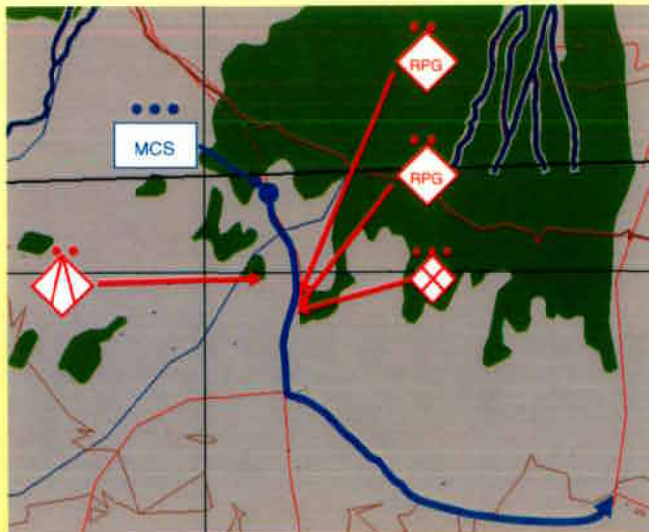

DCE1: Experiment Design

- Assess aggregate power consumption using CASTFOREM
- Extract vignette
 - 9 hours into battle
 - MCS PLT
 - Road March (12 km)
 - Dismount ambush
- Drive + defensive systems

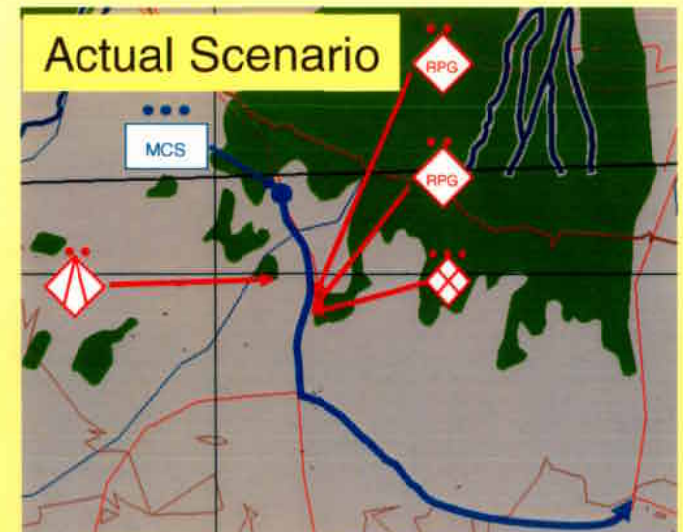
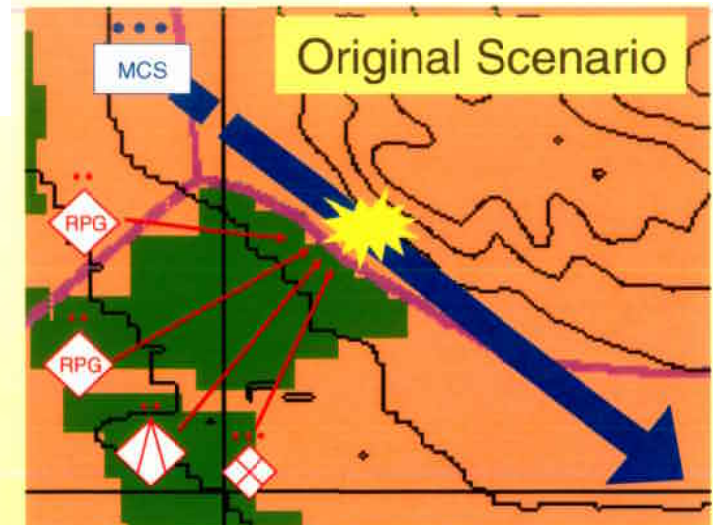

DCE1: OTB Implementation

- Implemented in OTB 2.0
- Blue forces:
 - 3 SAF M1
 - “Alpha 1” – “Alpha 3”
 - 1 Virtual MCS
 - “Alpha 4”
- Red forces
 - RPG
 - ATGM

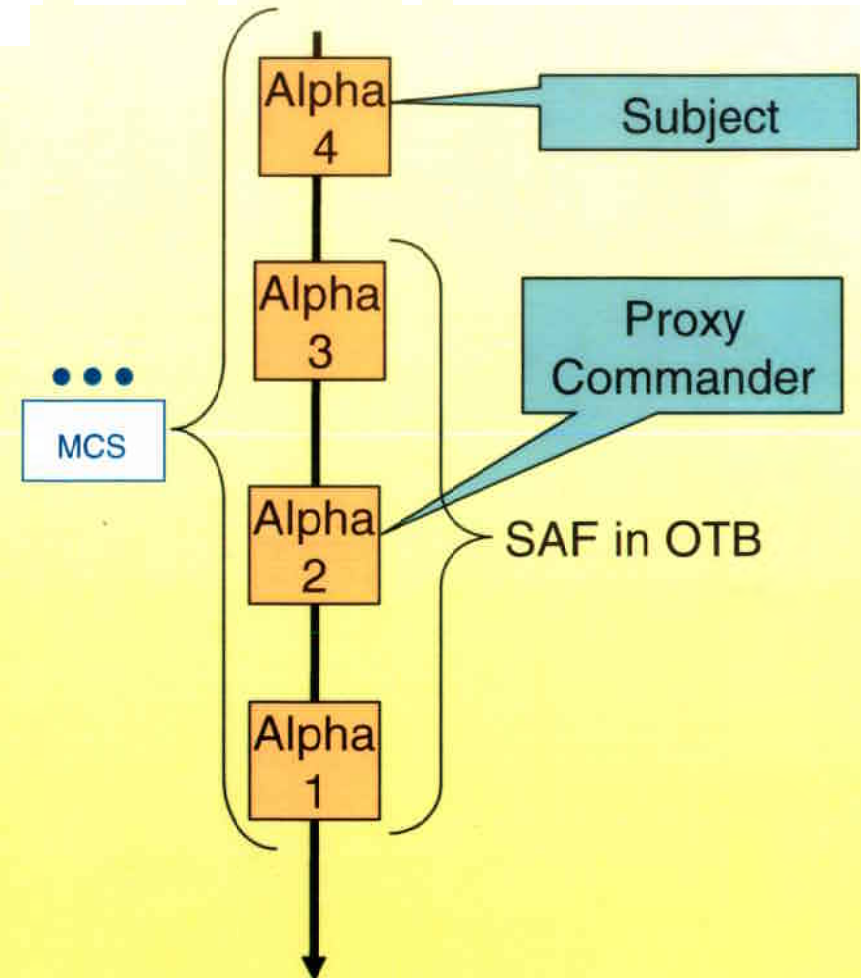

DCE1: Proxy Commander

- Serve as PLT leader
- Give direction
- Maintain “chatter”
- Give mission briefing
- Monitors OTB



Voice



DCE1: Data Acquisition

- 57 channels of data at 100 Hz
 - 31 vehicle dynamics
 - 26 power system
- Video of experiment
 - hit,
 - transmission
- PDU log

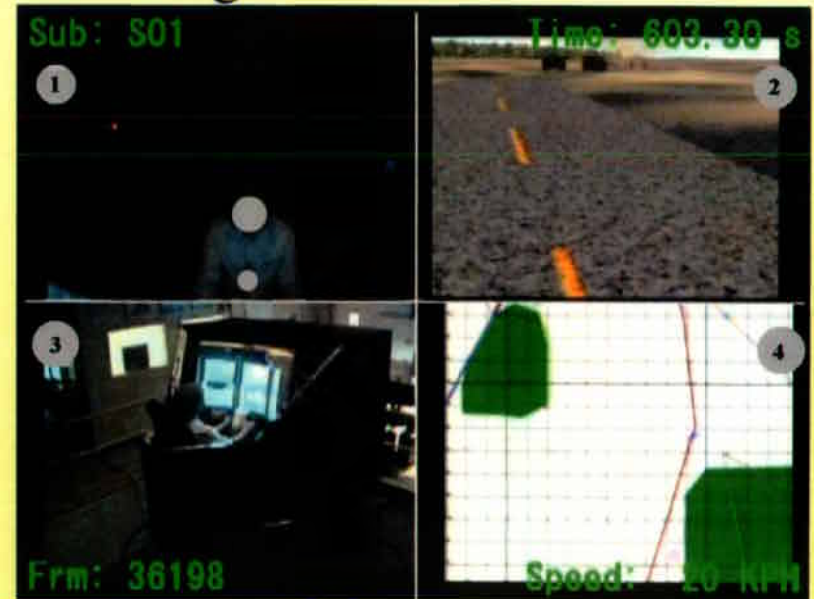
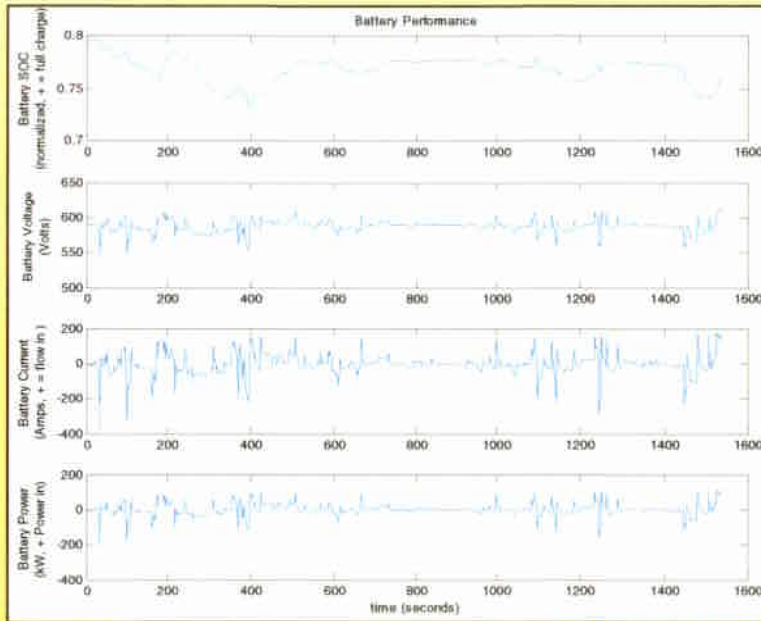

DCE1.1: Experiment Design

- Drive one lap on hilly Army proving ground course.
- Record driver commands, speed, location.
- Seven subjects drawn from experimenters

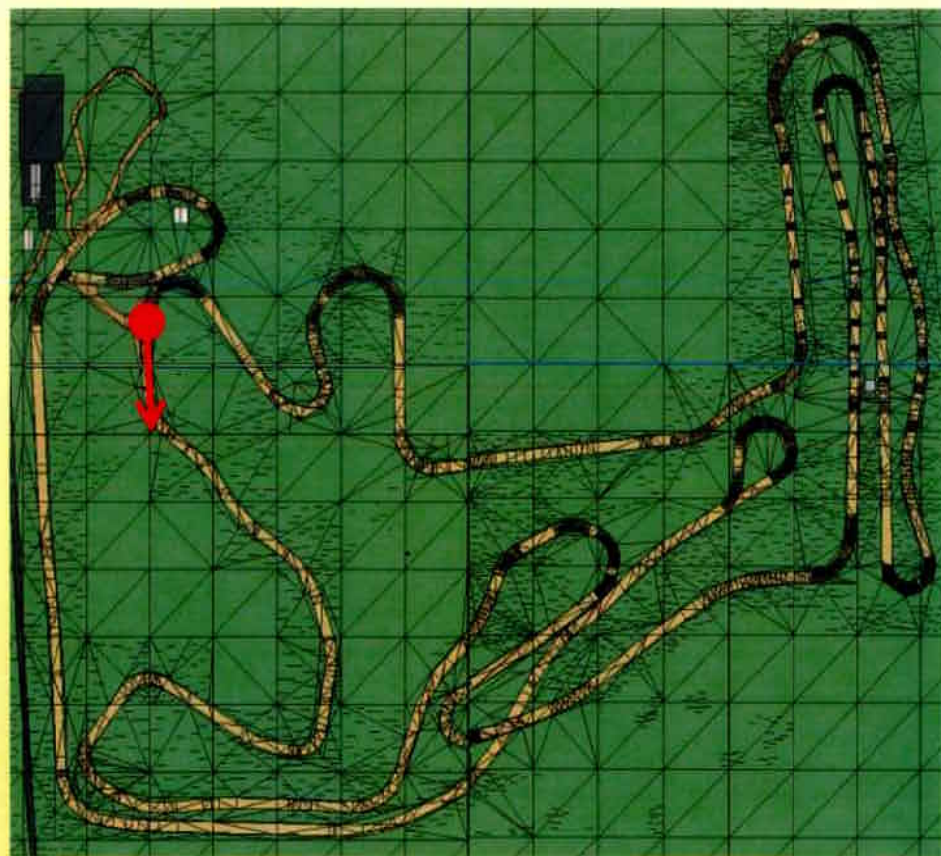

DCE1: Subject Handling

- Affidavits and questionnaires
 - Consent form
 - Simulation Sickness Questionnaire (1 of 3)
 - Demographics Questionnaire
- Mission Briefing
- Practice drive
- Simulation Sickness Questionnaire (2 of 3)
- **Conduct experiment**
- Simulation Sickness Questionnaire (3 of 3)
- Exit Interview

~ 2 hours

DCE1 Results: Demographics

- 9 Subjects (7 male, 2 female)
 - Age 29 ± 2.2 years
 - Education: 4.7 years ± 0.3 yrs post HS.
 - Driving exp: 13 ± 2.4 yrs.
 - Military vehicle exp: 5 subjects
 - None with tracked vehicle exp
 - Computer use: 46 ± 7 hrs/wk.
 - Video game exp: 5.8 ± 1.5 hrs/mo.

DCE1 Results: Duty cycle

- 6 subjects completed
- 3 ended early – computer crash
- No significant simulator sickness

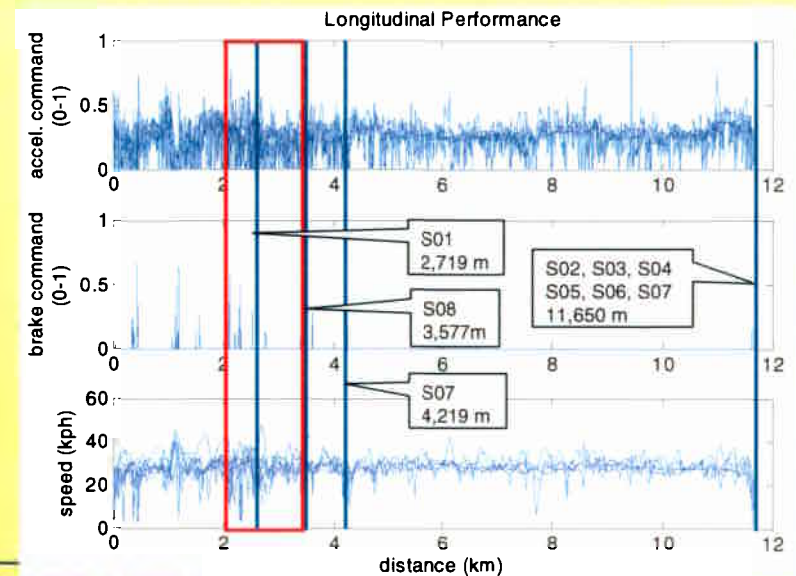
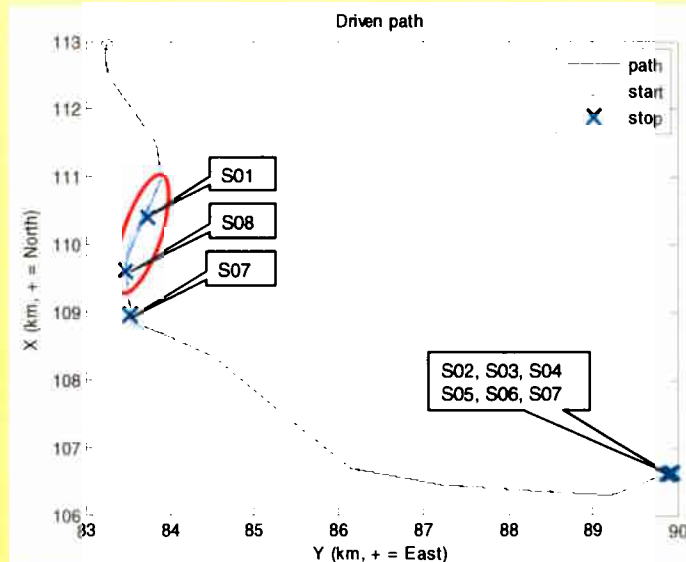
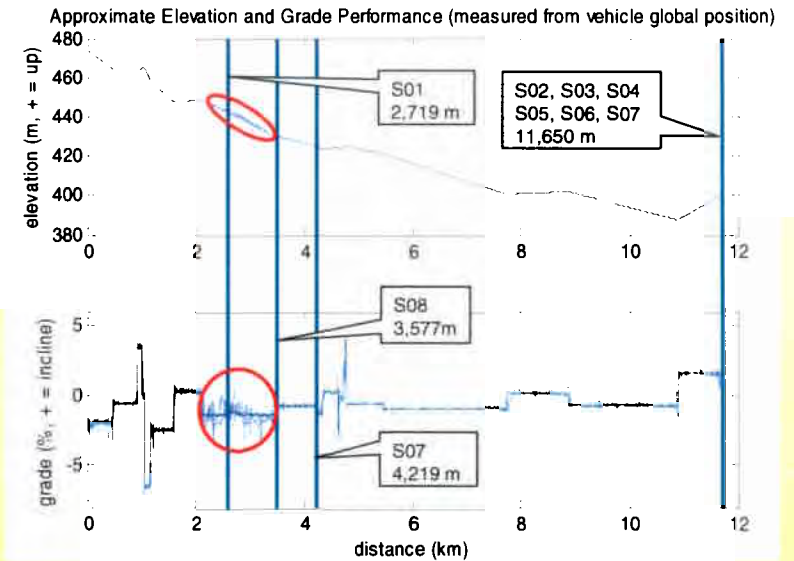

DCE1.1 Results: Duty cycle

- 7 subjects completed
- Lap times
–14.2 – 22.4 minutes
- Turns divergence

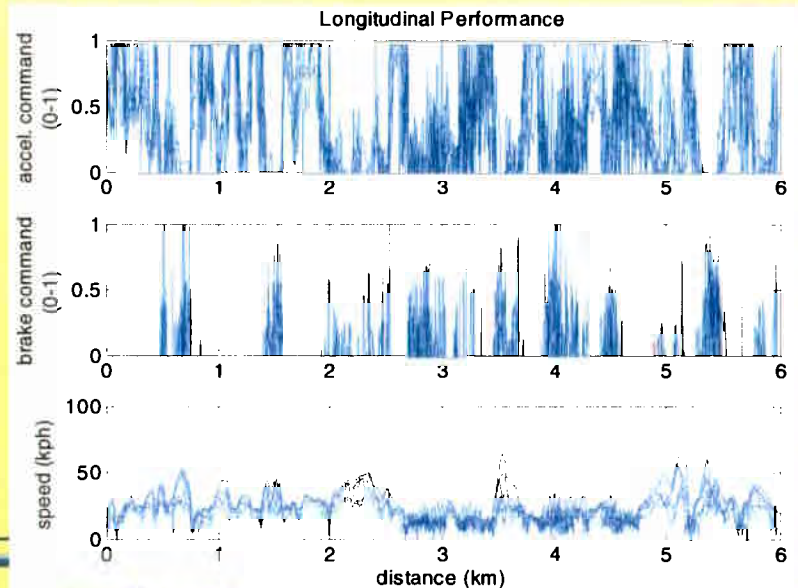
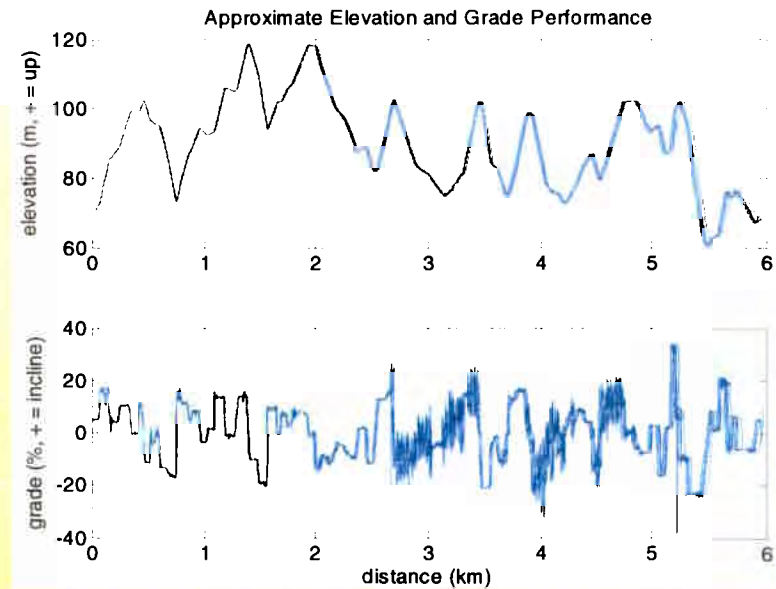
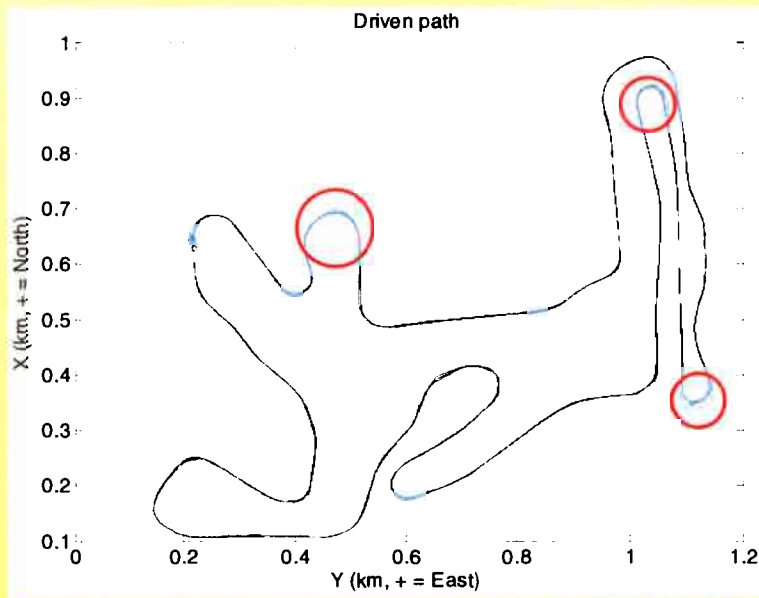

DCE1.1 Results: Path Averaging

- Find average path
- Synchronize data at each point.
- 2m averaging

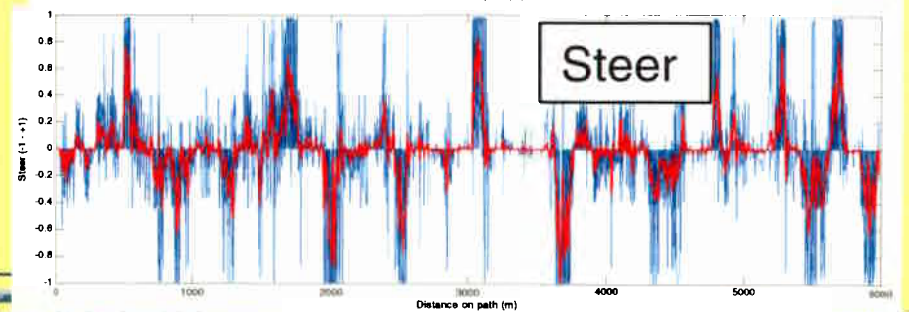
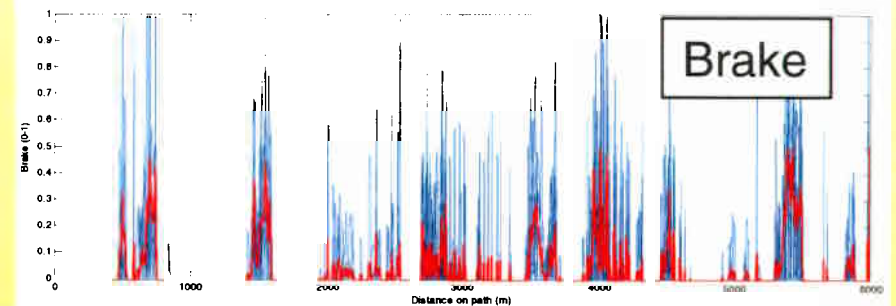
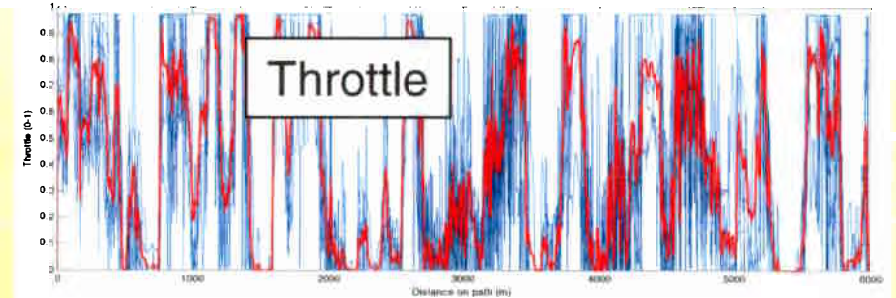
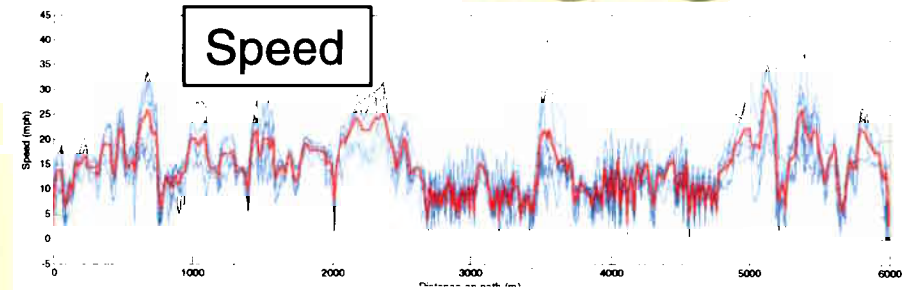
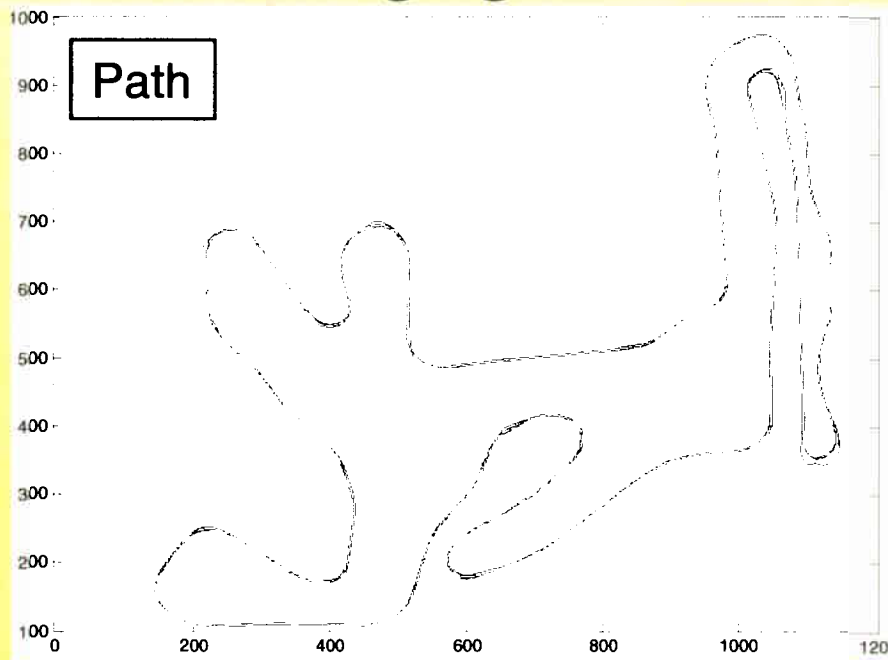

DCE1.1 Results: Path Averaging

Path

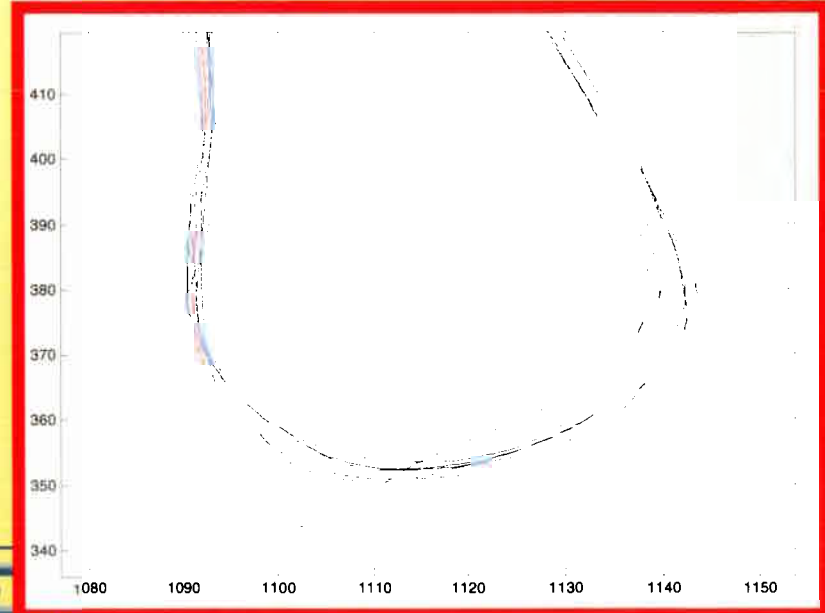
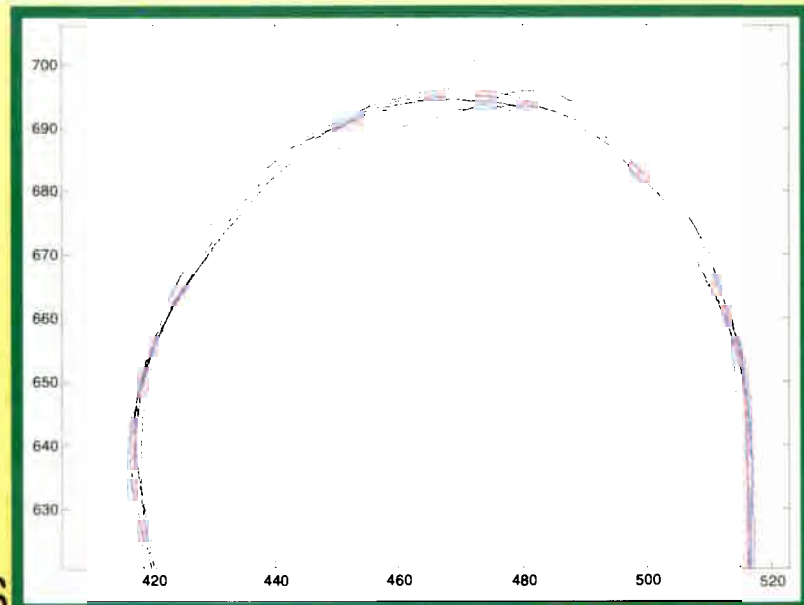
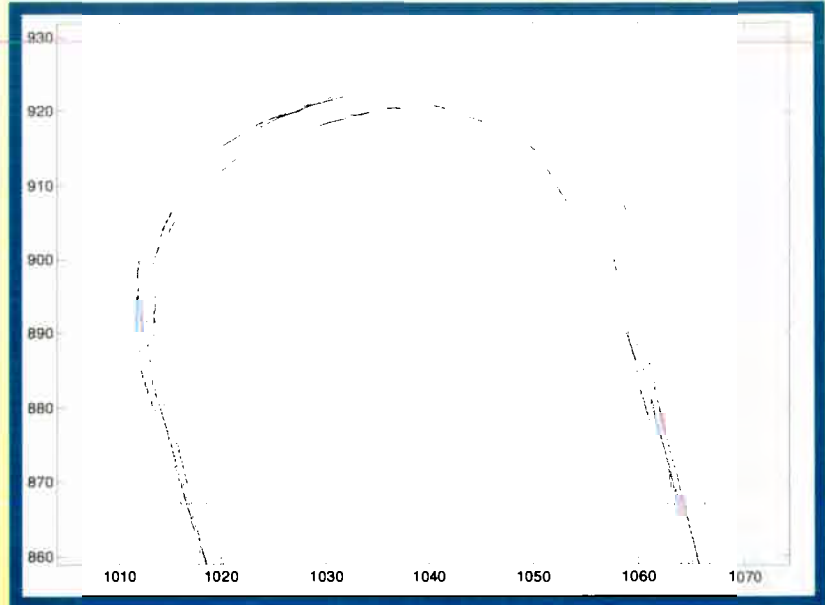
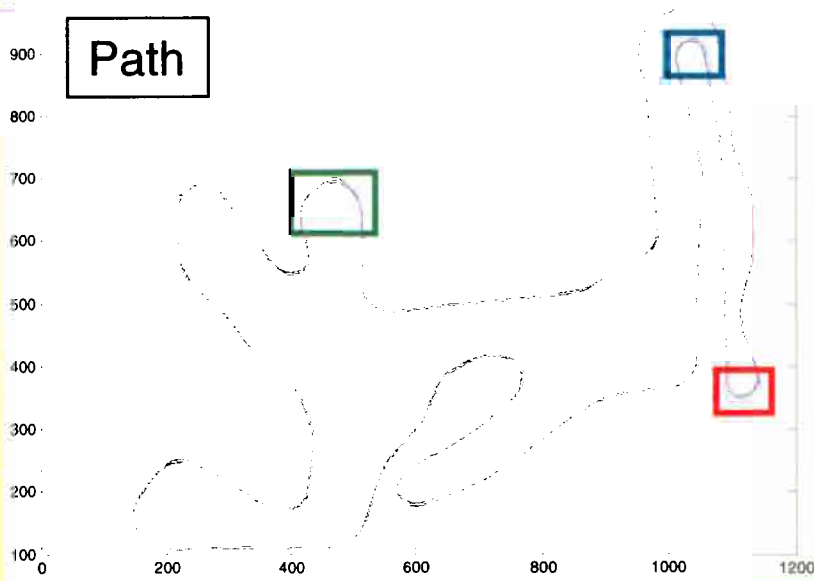

06S-S



2006 Spring SIW

Conclusions

- Two duty cycles were recorded.
 - Battle scenario with driving and defensive systems.
 - Power train evaluation course.
- Motion base simulation affects how a vehicle is operated.
- A scenario may be extracted from a force-on-force simulation and executed at a higher resolution.