

K. Ware, N. Loter, M. Montgomery,  
J. Rauch and J. Shannon  
Maxwell Laboratories, Inc.  
San Diego, CA 92123

### INTRODUCTION

The DNA/Maxwell high power generator, BLACKJACK 5, has been developed as a versatile bremsstrahlung radiation source for nuclear weapon simulation testing. Three different e-beam geometries are available to efficiently match the dose/area requirements of the test objects. A 25 cm dia annular ring e-beam has been well characterized to produce 22 krads-Si with a 2:1 uniformity over a 1000 cm<sup>2</sup> test area in a 50 ns pulse. This diode and radiation source will be described in detail along with several radiation diagnostic techniques. For small area test objects, a pinched e-beam diode has been designed and partially characterized. Dose measurements of 30 krads-Si at 10.5 cm suggest that up to 500 krads-Si or 25 cal/cm<sup>2</sup> should be available at 2.5 cm from the bremsstrahlung converter. A 90 cm dia ring e-beam has been designed for efficient radiation exposures to test objects larger than 10,000 cm<sup>2</sup>. This source should produce 2.3 krads-Si over these larger areas. The diodes are nominally operated in the 1 to 2 MV mean e-beam potential range, however, the system can be adjusted to deliver high x-ray fluences with lower mean e-beam potentials.

### BLACKJACK 5 BREMSSTRAHLUNG SYSTEM

BLACKJACK 5, shown in Figure 1, was first operated as a 1 to 2 MeV bremsstrahlung radiation source in the fall of 1984. This 4 m dia, water dielectric pulseline is driven by a 1.5 MJ multistaged Marx capacitor bank charged to  $\pm 50$  kV. The pulseline has five line sections separated by self breaking water switches which condition the energy to over a tenfold increase in power. The first pulseline section, transfer capacitor, is charged to 1.0 MJ in

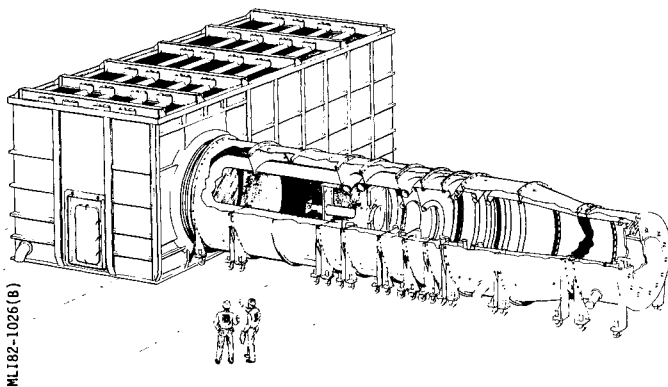

Figure 1. BLACKJACK 5 Marx tank and 4 m dia water-filled pulseline.

\*Work supported by the Defense Nuclear Agency under Contract DNA001-84-C-0011.

1.8  $\mu$ s before closure of the first switch and 600 kJ can be delivered to a 0.6  $\Omega$  matched dummy load in an 80 ns power pulse. Figure 2 shows these pulseline energetics where 40 percent of the energy delivered to the transfer capacitor was lost due to power conditioning in the pulseline and water switches. With a vacuum e-beam load diode the delivered energy was further reduced to about 300 kJ in a 58 ns pulse due to the diode inductance and the collapsing impedance of the load. These pulseline energetics were measured with the 25 cm dia annular ring cathode load.

The diode geometry for the 25 cm dia bremsstrahlung source is shown in Figure 3. The vacuum power flow through the 2 cm gap between the cathode and the anode is aided by magnetic insulation. The power is fed to the continuous ring cathode emitter by several posts which extend through holes in the anode. Convoluting the current paths in this way sets up self-magnetic forces on the beam electrons to form a stabilized ring e-beam. Typical e-beam voltage and current waveforms for this diode geometry are shown in Figure 4 for a  $\pm 50$  kV charge voltage. Both the signals were measured in the water-pulseline just before the vacuum diode and the voltage trace has been corrected for the inductance of the diode. The A-K gap was set at 1.3 cm for this high voltage e-beam but gaps as low as 4 mm have been used for lower voltage mode of operation.

Figure 3 also shows the details of the bremsstrahlung anode converter package. The electron beam passes through the 0.51 mm aluminum anode into the 0.71 mm tantalum converter where most of the bremsstrahlung radiation is produced. The aluminum is used as mechanical support for the tantalum. The electrons which are not stopped by the tantalum are absorbed by the 4.4 mm Grafoil scavenger. The scavenger is used to prevent direct e-beam heating of the catcher. The vaporized tantalum and graphite generate a high pressure gas which is contained by the 3.5 mm layer of Kevlar laminant from Russell Plastics. This catcher sometimes undergoes some

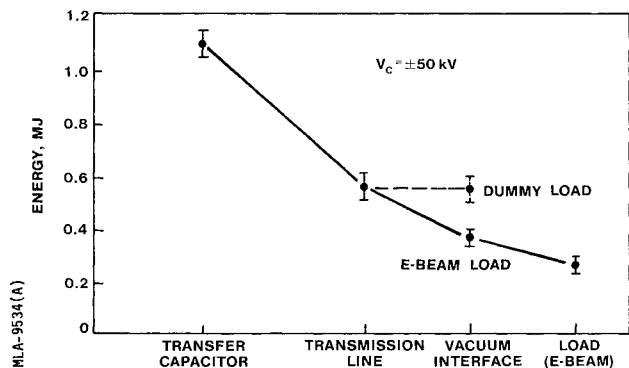

Figure 2. The pulseline energy delivered to the e-beam load is limited because of the A-K gap closure.

## Report Documentation Page

*Form Approved*  
*OMB No. 0704-0188*

Public reporting burden for the collection of information is estimated to average 1 hour per response, including the time for reviewing instructions, searching existing data sources, gathering and maintaining the data needed, and completing and reviewing the collection of information. Send comments regarding this burden estimate or any other aspect of this collection of information, including suggestions for reducing this burden, to Washington Headquarters Services, Directorate for Information Operations and Reports, 1215 Jefferson Davis Highway, Suite 1204, Arlington VA 22202-4302. Respondents should be aware that notwithstanding any other provision of law, no person shall be subject to a penalty for failing to comply with a collection of information if it does not display a currently valid OMB control number.

1. REPORT DATE <b>JUN 1985</b>	2. REPORT TYPE <b>N/A</b>	3. DATES COVERED <b>-</b>			
4. TITLE AND SUBTITLE <b>Bremsstrahlung Source Development On Blackjack 5</b>		5a. CONTRACT NUMBER			
		5b. GRANT NUMBER			
		5c. PROGRAM ELEMENT NUMBER			
6. AUTHOR(S)		5d. PROJECT NUMBER			
		5e. TASK NUMBER			
		5f. WORK UNIT NUMBER			
7. PERFORMING ORGANIZATION NAME(S) AND ADDRESS(ES) <b>Maxwell Laboratories, Inc. San Diego, CA 92123</b>		8. PERFORMING ORGANIZATION REPORT NUMBER			
9. SPONSORING/MONITORING AGENCY NAME(S) AND ADDRESS(ES)		10. SPONSOR/MONITOR'S ACRONYM(S)			
		11. SPONSOR/MONITOR'S REPORT NUMBER(S)			
12. DISTRIBUTION/AVAILABILITY STATEMENT <b>Approved for public release, distribution unlimited</b>					
13. SUPPLEMENTARY NOTES <b>See also ADM002371. 2013 IEEE Pulsed Power Conference, Digest of Technical Papers 1976-2013, and Abstracts of the 2013 IEEE International Conference on Plasma Science. Held in San Francisco, CA on 16-21 June 2013. U.S. Government or Federal Purpose Rights License.</b>					
14. ABSTRACT					
15. SUBJECT TERMS					
16. SECURITY CLASSIFICATION OF:			17. LIMITATION OF ABSTRACT <b>SAR</b>	18. NUMBER OF PAGES <b>4</b>	19a. NAME OF RESPONSIBLE PERSON
a. REPORT <b>unclassified</b>	b. ABSTRACT <b>unclassified</b>	c. THIS PAGE <b>unclassified</b>			

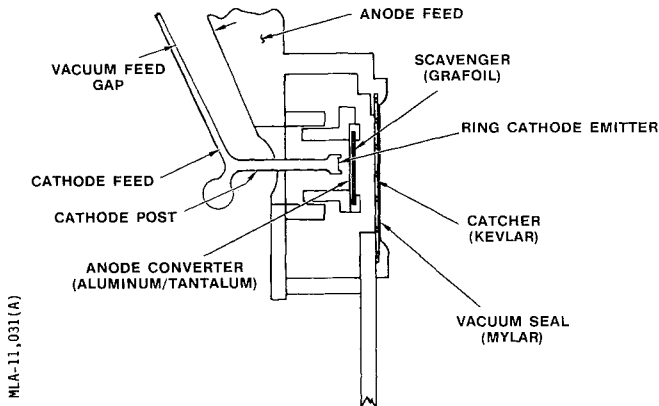

Figure 3. Details of the convoluted diode geometry for the 25 cm dia bremsstrahlung source.

permanent axial deformation but remains intact. The x rays must pass through this catcher so the thickness is minimized and for this configuration accounts for only a 20% loss in the available dose.

#### RADIATION DIAGNOSTICS

Figure 5 shows a schematic drawing of the vacuum diode and the positions of the several radiation diagnostics employed during the bremsstrahlung development on BLACKJACK 5. The pinhole camera records the image of the radiation emanating from the tantalum converter as shown in Figure 6. As can be seen, the e-beam is a reasonably uniform annular ring with about a 1.5 cm width and 25 cm diameter. Two silicon calorimeters located in the near field at 8 cm from the tantalum shadow the pinhole camera image in Figure 6. Three densitometer scans of pinhole images for different bremsstrahlung shots are shown in Figure 7. Illustrated is the effect of changing the inner or outer diameter of the anode return current paths, using inductive shims, on the mean diameter of the e-beam current. This is a useful technique for optimizing the emission pattern for the radiation and for controlling the radial location of an ion plasma which could lead to early gap closure.

The photodiode flux monitor used in the far field has been filtered to give a nearly flat response over the radiation range from 30 keV to 6.0 MeV. Figure 8 shows an x-ray pulse taken with this flux monitor for a full power  $\pm 50$  kV shot on BLACKJACK 5 with a 50 ns pulse width. Before installation of an oil prepulse switch in the transmission line, these radiation pulses were around

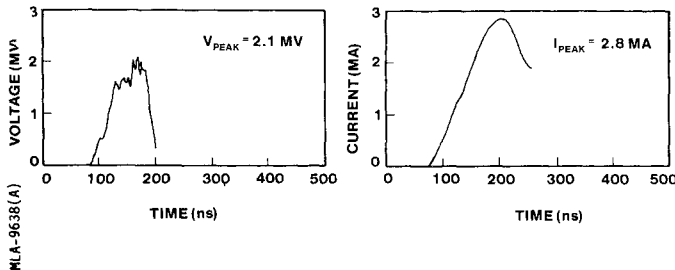

Figure 4. Typical e-beam voltage and current waveforms for the 25 cm dia ring diode.

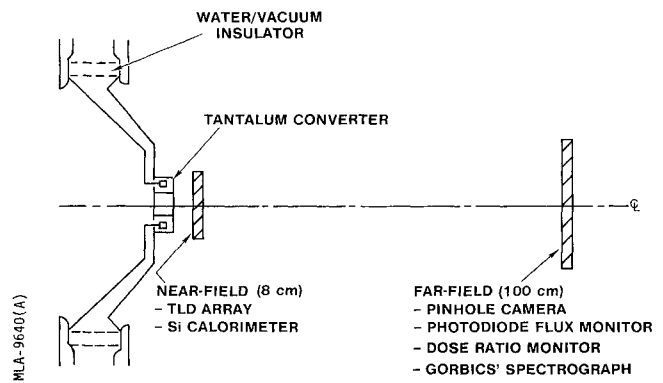

Figure 5. A typical diagnostic set-up for BLACKJACK 5 bremsstrahlung development is shown in front of the diode.

35 ns FWHM. It is believed that prepulse voltage leads to early anode plasma formation and early A-K gap closure. Some truncation of the gap impedance and radiation pulse still occurs with BLACKJACK 5 and further studies of the electrode surface physics will be required to establish the full 70 ns radiation pulse width potential of this machine.

Along with the flux monitor, a far field dose ratio monitor is used to characterize the total radiation source for each shot. This monitor uses two sets of TLD-200s ( $\text{CaF}_2:\text{Dy}$ ). One set is located behind 0.25 mm of aluminum and the second set is behind 25 mm of lead. Using the dose in the front set of TLDs and the dose ratio to the back set, one can calculate a peak or mean e-beam potential and the energy content of the e-beam. These calculations based on the TLD readings averaged only 7% lower in voltage and 29% lower in energy over a 33 shot series than the measured electrical load voltages and energies. Also, the far field dose at 100 cm measured by the front TLDs, is a useful parameter to characterize the strength of the radiation source both for diode efficiency and shot-to-shot variation. The 25 cm annular source produced an average peak dose of 536 rads-Si at 100 cm, for twelve subsequent  $\pm 50$  kV charge voltage shots. The average doses at 100 cm for the  $\pm 45$  and  $\pm 40$  kV shots were lower than this by about the ratio of available energy at 420 and 356 rads-Si, respectively.

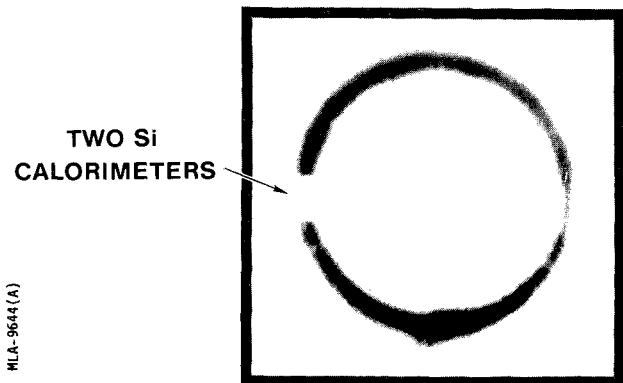

Figure 6. X-ray image of the BLACKJACK 5 25 cm dia tantalum converter showing the location of the silicon calorimeters.

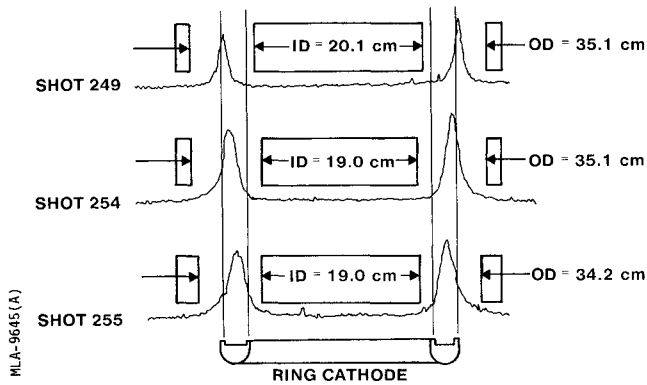

Figure 7. The annular diameter of the bremsstrahlung radiation source is adjusted by moving the e-beam current with inductance shims.

For two shots, a TLD spectrograph\*\* supplied by S. Gorbics of the Naval Research Laboratory was used to directly measure a spectral response function which has been unfolded for the spectrum shown in Figure 9. Also shown in the figure, for comparison, is a calculated spectrum based on the measured electrical signals for e-beam voltage and current. The agreement is reasonably good and the spectra integrate to fluences of 13 and 16 mcal/cm<sup>2</sup> for the TLD spectrograph and electrical calculation respectively at 100 cm from the source. The indicated doses in 20 mil silicon for these two spectra were both at 400 rads-Si as compared with the TLD-200 measured far field dose of 471 rads-Si for this shot. These spectral measurements have now benchmarked the calculations to within  $\pm 10\%$  accuracy for integrated effects and to within a factor of two for detailed spectral characteristics.

In the near field, the radiation diagnostics were primarily a TLD array and a pair of 20 mil silicon calorimeters for each shot to establish the area-averaged dose in silicon for a 1000 cm<sup>2</sup> target. The location for this array was at 8 cm from the tantalum converter giving a dose ratio of max/min of 2:1 over the 1000 cm<sup>2</sup> area. Figure 10 shows a horizontal, radial dose profile for a  $\pm 50$  kV

\*\*D.A. Whittaker, K. Kerris, M. Litz, S.T. Gorbics, and N.R. Pereira, "Softening of hard bremsstrahlung by Compton back scattering," to be published in *J. Appl. Phys.*

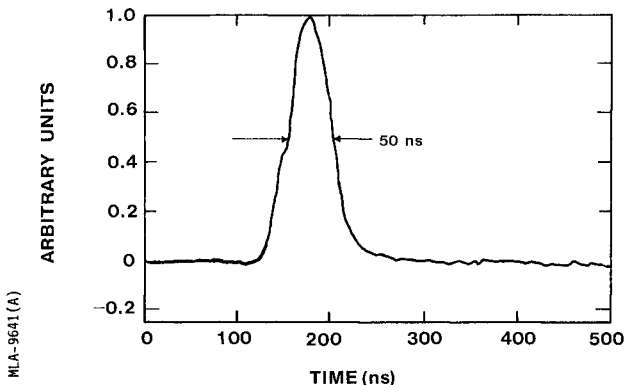

Figure 8. The far field x-ray flux for bremsstrahlung radiation.

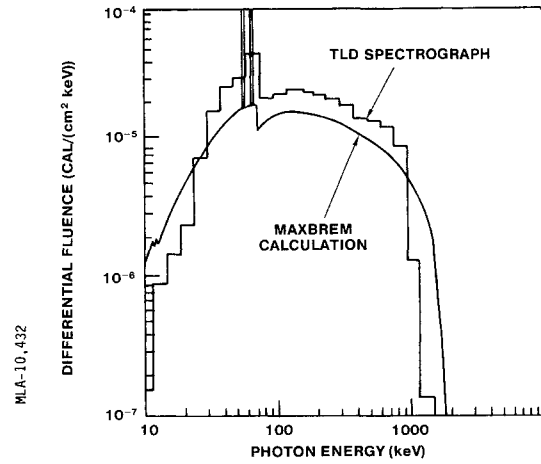

Figure 9. Comparison of the bremsstrahlung spectra calculated from electrical measurements and as measured by a TLD spectrograph for BLACKJACK 5.

charge voltage shot on BLACKJACK 5. This shot yielded 20.9 krads-Si averaged over the 1000 cm<sup>2</sup> which was about 80 percent of the peak dose at this axial location. The dose TLD-200 (CaF<sub>2</sub>:Dy) to dose silicon ratio was carefully measured to be  $1.04 \pm 3\%$  for this particular radiation geometry and converter package filtered spectrum. For other geometries and spectra, this ratio can vary from over 2 to 0.3 which demonstrates the usefulness for routinely measuring it. All dose measurements quoted in rads-Si in order to be reliable should have traceable documentation to a direct silicon dose measurement.

#### BREMSSTRAHLUNG SOURCE RESULTS

##### Normal Operation

Figure 11 is an isodose contour mapping for the 25 cm dia ring bremsstrahlung source as calculated from the diode electrical measurements and normalized to the 22 krads-Si measured over 1000 cm<sup>2</sup> at 8 cm for  $V_c = \pm 50$  kV. The far field dose of 680 rads-Si at 100 cm agrees well with the far field measurements made during these optimized full bank energy shots. Note that a 10,000 cm<sup>2</sup> target would need to be located at 82 cm with an area average dose of just 800 rads-Si for this diode geometry. A more efficient large area bremsstrahlung source for targets over 10,000 cm<sup>2</sup> would be possible with a

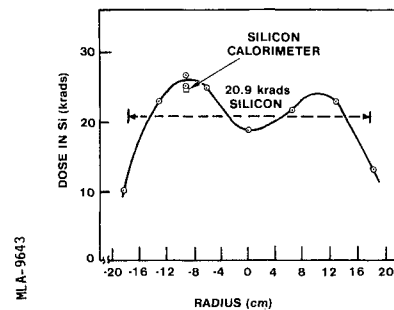

Figure 10. The horizontal, radial dose profile as measured by several TLD-200s (CaF<sub>2</sub>:Dy) and a silicon calorimeter yielded an area weighted mean dose of 20.9 krads-Si over 1000 cm<sup>2</sup>.

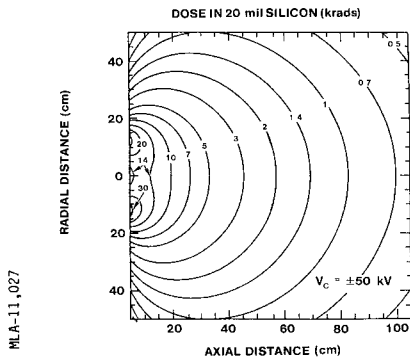

Figure 11. Isodose contour lines calculated for the 25 cm dia annular e-beam and scaled to measured silicon calorimeter data.

90 cm dia e-beam. Design for this scaled-up convoluted ring e-beam diode geometry with a 90 cm dia cathode has been completed and will be tested this summer. The expected area averaged dose is 2.3 krad-Si over a 10,000 cm<sup>2</sup> target located at 25 cm from the converter. The isodose contour mapping predicted for this source is shown in Figure 12. The far field dose for the 90 cm dia e-beam is 50% higher than the 25 cm dia e-beam. This increase in radiation is due to the use of a lower mass density catcher package for the lower energy density e-beam and the expected increased energy transfer to the e-beam for this diode due to lower inductance and A-K gap closure rate.

For higher dose exposures over smaller areas, less than 200 cm<sup>2</sup>, a pinched e-beam diode geometry is used with BLACKJACK 5. The cathode feed is no longer convoluted so that the self-magnetic forces will pinch the e-beam to the axis over a few square centimeters area. The isodose contour mapping calculated for this source is shown in Figure 13 which has been scaled from the measured dose of 30 krad-Si at ±40 kV as indicated. Doses as high as 500 krad-Si at fluences up to 25 cal/cm<sup>2</sup> are suggested by this isodose mapping to be available over small areas near the converter.

The three bremsstrahlung sources are compared directly in the composite curves in Figure 14 where the area averaged mean dose in 20 mil silicon has been plotted versus the area with a 2:1 uniformity for the three different diode geometries at ±50 kV charge voltage. The pinched e-beam source has been scaled from the ±40 kV charge voltage dose measured at 10.5 cm as indicated. The 25 cm dia source has been measured and the 90 cm dia source was calculated.

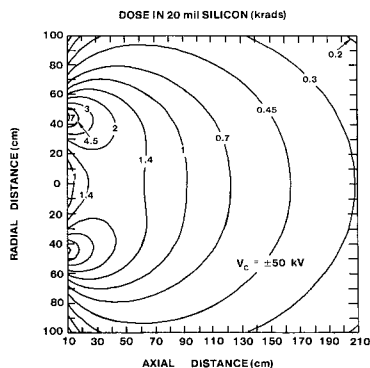

Figure 12. Isodose contour lines predicted for BLACKJACK 5 using the 90 cm dia annular e-beam.

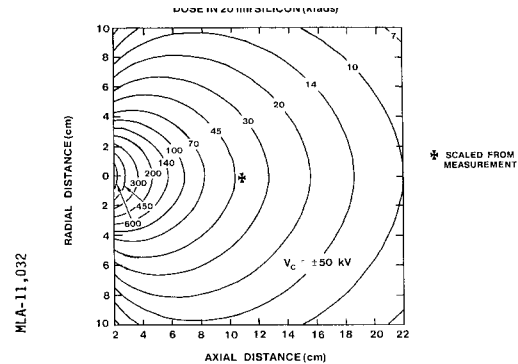

Figure 13. Isodose contour lines calculated for the pinched e-beam and scaled from silicon calorimeter measurements at V<sub>c</sub> = ±40 kV.

ted. This presentation of the dose data clearly illustrates the value of using different diode geometries for different size test objects.

### Low Voltage Operation

A very brief evaluation of BLACKJACK 5 bremsstrahlung performance at extreme low e-beam voltage was attempted by operating at the lowest practical pulseline voltage and minimum diode impedance. Although the machine was designed to operate at much higher voltage, it was found possible to achieve bremsstrahlung operation at a power weighted mean e-beam voltage as low as 300 kV. Using the 25 cm dia ring cathode, shots at e-beam voltages of 300 and 800 kV with radiation pulse widths of 50 and 75 ns and doses of 135 and 350 rads-Si at 1 m were achieved, respectively. These measurements indicate a fluence of 0.37 mcal/cm<sup>2</sup> over 10,000 cm<sup>2</sup> is available at 300 kV. Significantly better performance, perhaps more than a factor of 10, is expected from the 90 cm dia cathode for large (10,000 cm<sup>2</sup>) area exposures.

### Acknowledgement

The authors wish to thank Major J. Benson of the Defense Nuclear Agency and F. Graham of Maxwell Laboratories, Inc. for their suggestions for improvement of the initial manuscript and useful consultations during the experiments, and to G. Quayle and the BLACKJACK 5 technical team lead by C. Wright for their support during the experimental effort.

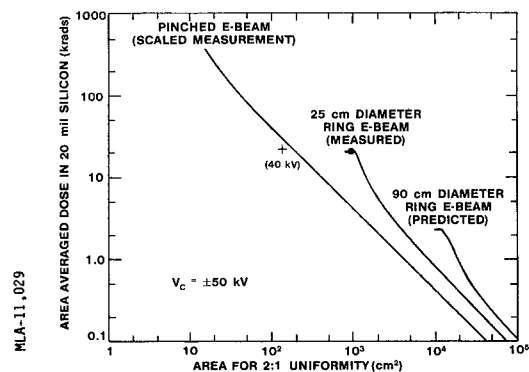

Figure 14. Area averaged mean dose available from BLACKJACK 5 operated in pinched beam, intermediate area (1000 cm<sup>2</sup>), and large area (10,000 cm<sup>2</sup>) bremsstrahlung modes.