

EXPERIMENTAL INVESTIGATION OF A FAST-ACTING
EXPLODING METALLIC FOIL OPENING SWITCH*

N. E. Molau, J. E. Vernazza, R. A. Anderson,
D. A. Goerz, and R. R. Heritsch
Lawrence Livermore National Laboratory
University of California
Livermore, CA 94550

Abstract

Experiments were conducted to investigate the use of thin radially spoked metallic foils as fast-acting opening switches operating on nanosecond timescales. Such devices could be useful in special applications requiring a tailored output from a pulsed power source. The advantage of this concept is that the device is inexpensive, simple, rugged, and reliable for single shot applications.

Experimental results are presented and discussed. The effects of varying several fuse parameters are summarized and some limitations of the design are discussed.

Introduction

In the past, metallic foil fuses have been used for current interruption and switching for timescales ranging from hundreds of microseconds down to hundreds of nanoseconds.^{1,2,3} The purpose of this work was to explore the feasibility of using very thin metallic foils as opening switches operating in the 1 to 10 ns time regime. Our particular objective was to pulse sharpen and perhaps step-up the output of our pulsed power source in order to generate a very fast, gaussian-like voltage pulse. These tests were carried out to provide immediate experimental evidence and were done without the benefit of significant analytical or computational efforts.

Experimental Setup

LLNL's 2-MV accelerator is used as the pulsed power source for the experiment whose overall configuration is shown in Fig. 1. The output of the accelerator has a 60-ns pulse width and a 13-ns 10% to 90% rise time. A 3-m-long, 13.8-ohm magnetically insulated transmission line (MITL) is used to sharpen the rise time of the pulse to somewhere between 5.5 ns and 7 ns depending on the specifics of the shot. The voltage pulse is applied to a vacuum diode generating a 160-kA electron beam. Fig. 2 shows a detailed drawing of the experimental hardware in the diode region. The electron beam impinges upon the center conductor of a 1-m-long, 41.6-ohm coaxial vacuum

insulated transmission line (VITL), producing a voltage pulse given by $I(t) \times Z_{line}$.

The radially spoked metallic foil fuse resembling a very thin carriage wheel is inserted near the electron beam stop and serves to shunt current between the inner and outer electrodes of the VITL until the fuse bursts. The axial plane labeled "B" in Fig. 2 shows the location of the fuse. Fig. 3 shows both a front and a side view of a typical 8-spoke fuse. The fuse geometry and fabrication techniques are described in greater detail in a later section entitled "Fuse Geometry".

The diagnostics consisted of many B-dot probes and several current-viewing-resistors (CVRs). Several B-dot probes were located at intervals along the outer conductor of the MITL and were used to measure the current along the MITL. Five B-dot probes were located at various azimuthal locations near the end of the MITL several inches in front of the fuse as shown by the axial plane labeled "A" in Fig. 2. These B-dot probes were used to measure the input current to the fuse. Five additional B-dot probes were located at various azimuthal locations on the VITL a short distance behind the fuse as shown by the axial plane labeled "C" in Fig. 2. A CVR was located directly adjacent to these probes. Two additional CVRs were located at 0.5-m intervals along the VITL. These sensors were used to measure the voltage pulse launched down the VITL when the fuse opened.

Measurement System Setup

The measurement system was comprised of sensors, recording instruments, and either equalized coaxial cables or a fiber optic link connecting the two. Timing markers were used on all recording instruments so as to provide crosstiming between the various data channels. The crosstiming error between data channels was roughly 1 ns for data taken on the same shot and roughly 1.5 ns for data taken on different shots.

Because we were expecting to measure fast waveforms during this experiment, great care was taken to determine the bandwidth limitations of our measurement system. The B-dot probes and CVRs were

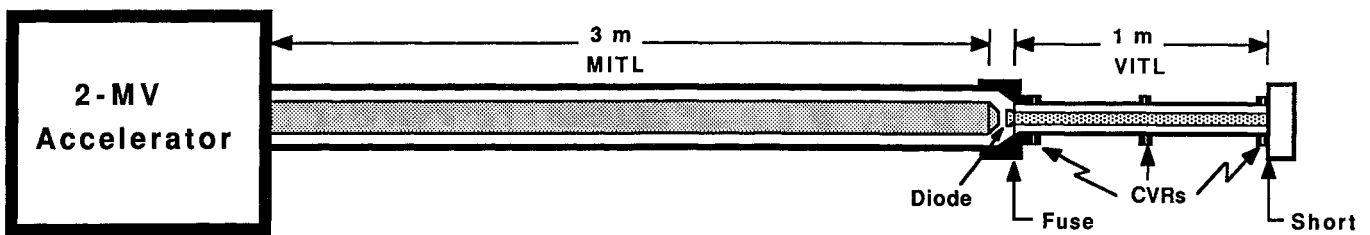

Figure 1. Layout of the overall experimental configuration.

* This work was performed under the auspices of the U.S. Department of Energy by the Lawrence Livermore National Laboratory under contract number W-7405-ENG-48.

Report Documentation Page

Form Approved
OMB No. 0704-0188

Public reporting burden for the collection of information is estimated to average 1 hour per response, including the time for reviewing instructions, searching existing data sources, gathering and maintaining the data needed, and completing and reviewing the collection of information. Send comments regarding this burden estimate or any other aspect of this collection of information, including suggestions for reducing this burden, to Washington Headquarters Services, Directorate for Information Operations and Reports, 1215 Jefferson Davis Highway, Suite 1204, Arlington VA 22202-4302. Respondents should be aware that notwithstanding any other provision of law, no person shall be subject to a penalty for failing to comply with a collection of information if it does not display a currently valid OMB control number.

1. REPORT DATE JUN 1989	2. REPORT TYPE N/A	3. DATES COVERED -	
4. TITLE AND SUBTITLE Experimental Investigation Of A Fast-Acting Exploding Metallic Foil Opening Switch		5a. CONTRACT NUMBER	
		5b. GRANT NUMBER	
		5c. PROGRAM ELEMENT NUMBER	
6. AUTHOR(S)		5d. PROJECT NUMBER	
		5e. TASK NUMBER	
		5f. WORK UNIT NUMBER	
7. PERFORMING ORGANIZATION NAME(S) AND ADDRESS(ES) Lawrence Livermore National Laboratory University of California Livermore, CA 94550		8. PERFORMING ORGANIZATION REPORT NUMBER	
9. SPONSORING/MONITORING AGENCY NAME(S) AND ADDRESS(ES)		10. SPONSOR/MONITOR'S ACRONYM(S)	
		11. SPONSOR/MONITOR'S REPORT NUMBER(S)	
12. DISTRIBUTION/AVAILABILITY STATEMENT Approved for public release, distribution unlimited			
13. SUPPLEMENTARY NOTES See also ADM002371. 2013 IEEE Pulsed Power Conference, Digest of Technical Papers 1976-2013, and Abstracts of the 2013 IEEE International Conference on Plasma Science. Held in San Francisco, CA on 16-21 June 2013. U.S. Government or Federal Purpose Rights License.			
14. ABSTRACT Experiments were conducted to investigate the use of thin radially spoked metallic foils as fast-acting opening switches operating on nanosecond timescales. Such devices could be useful in special applications requiring a tailored output from a pulsed power source. The advantage of this concept is that the device is inexpensive, simple, rugged, and reliable for single shot applications. Experimental results are presented and discussed. The effects of varying several fuse parameters are summarized and some limitations of the design are discussed.			
15. SUBJECT TERMS			
16. SECURITY CLASSIFICATION OF:			17. LIMITATION OF ABSTRACT
a. REPORT unclassified	b. ABSTRACT unclassified	c. THIS PAGE unclassified	SAR
			18. NUMBER OF PAGES 4
			19a. NAME OF RESPONSIBLE PERSON

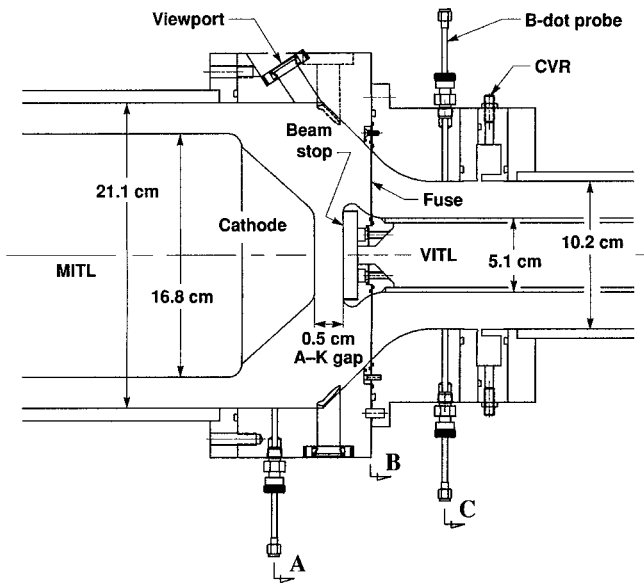

Figure 2. Detailed sketch of the diode and fuse region.

calibrated for both sensitivity and bandwidth. The B-dot probes had a bandwidth in excess of 3.5 GHz. The B-dot probe calibration setup was limited to 3.5 GHz and, consequently, no bandwidth information was available above this frequency. The CVRs had a bandwidth of 2 GHz.

Four different types of recording instruments were used: 500-MHz Tektronix 7912AD digitizers, 750-MHz Tektronix 7912HB digitizers, 1-GHz Tektronix 7104 oscilloscopes, and 6-GHz Tektronix 7250 transient digitizing oscilloscopes. The TEK 7250 oscilloscopes were connected to the experiment via a 1300-nm fiber optic link. All other recording instruments were connected to the experiment via cables which were equalized to over 1 GHz.

The recording instrument bandwidth was determined to be the limiting factor on the measurement system bandwidth except for those data channels utilizing the 6-GHz TEK 7250 oscilloscope in which case the limiting factor was the bandwidth of the sensor.

Fuse Geometry

The radial fuse consists of a very thin layer of metal in the shape of a carriage wheel supported by a thin disk-shaped substrate with a thin tamper covering the metal as shown in Fig. 3. The spokes are .254 cm wide and 4.49 cm long. A large matrix of different fuses was fabricated with variations in several parameters: type of metal, type of substrate, thickness of metal, number of spokes, type of tamper, and fabrication technique.

The majority of the fuses were made of aluminum on a 5-mil-thick kapton substrate. The thickness of the aluminum ranged from 0.15 μm to 7 μm . The number of spokes ranged from 8 spokes to 20 spokes. Three types of tampers were used: Krylon Workable Fixatif spray coating (uniformly sprayed across the fuse), 1-mil-thick kapton, and 5-mil-thick kapton. The disk-shaped kapton tamper was adhered to the aluminum fuse using a thermal heat process.

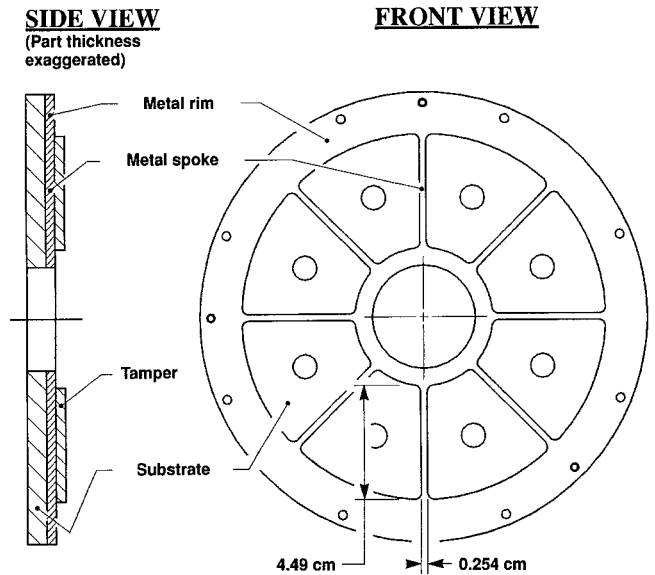

Figure 3. Front and side views of a typical 8-spoke fuse.

Two different techniques were used to fabricate the fuses. The first process entailed covering a disk of kapton substrate with a metal shadow mask leaving the desired fuse pattern exposed, then vapor-depositing the aluminum onto the exposed substrate material. The second approach used a chemical etch technique similar to that used in printed circuit board fabrication. A 0.25- μm -thick aluminum coating was uniformly vapor-deposited onto a 5-mil-thick kapton substrate. A photo-resist mask was applied and exposed to produce the desired fuse pattern, and the remaining metal was removed through a chemical etch process. Several 0.15- μm -thick copper fuses on 4-mil-thick polyester substrate were also fabricated using this chemical etch technique.

Results from a Typical Fuse

We begin our discussion of experimental results with a detailed look at a typical fuse having the following characteristics: 16 spokes, 0.25- μm -thick aluminum on 5-mil-thick kapton fabricated using the chemical etch technique, with a Fixatif spray tamper.

Fig. 4 shows the input current to the fuse as measured by a B-dot probe located on the MITL several inches in front of the fuse. The input current has a 7-ns 10% to 90% rise time and a 160-kA peak amplitude.

When the fuse opens, a pulse is launched down the VITL. Fig. 5 shows I-dot as measured by a B-dot probe located along the VITL a short distance behind the fuse. The signal measured by this B-dot probe is sent through a power divider and recorded on both a 1-GHz TEK 7104 oscilloscope (waveform "A") and a 6-GHz TEK 7250 oscilloscope (waveform "B").

It is apparent that the TEK 7250 oscilloscope records much more high frequency structure than does the lower bandwidth TEK 7104 oscilloscope. The origin of this high frequency structure has not yet been determined. Careful pulsed tests and characterization of the 1300-nm fiber optic link did not provide any indication that the signals are not "real". In fact, when a 1-GHz low pass filter is applied to the TEK 7250 data, it agrees quite well with the same data as

Effect of Varying Fuse Parameters

We have investigated the effect on fuse performance of varying several fuse parameters: metal coating thickness, number of spokes, type of tamper, and fabrication technique. Table 1 summarizes these results in terms of the effect on peak amplitude and FWHM of the output voltage pulse as well as on the burst time of the fuse. Each fuse parameter variation that was studied was performed with all other parameters held constant. The results listed in the "burst time of fuse" column describe trends that were observed but that, in some cases, were still within our crosstiming error limits.

Included in our study of metal coating thickness, were two 8-spoke, 7- μ m-thick fuses, one made of aluminum and one of copper, that appeared to have been too thick to burst. Consequently, this enabled us to determine the energy leakage between the spokes for the 8-spoke case. The peak output voltage measured on the VITL for these thick fuses was on the order of 125 kV.

Although the majority of the fuses that we tested consisted of an aluminum coating on a kapton substrate, several 0.15- μ m-thick copper fuses on 4-mil-thick polyester substrate were tested as well. These performed similarly to the 0.25- μ m-thick aluminum fuses on 5-mil-thick kapton substrate, having roughly the same peak output voltage and fuse burst time.

Limitations of the Radial Fuse Design

In coming up with a radially spoked fuse design we were faced with conflicting requirements. To keep the fuse inductance to a minimum, the spokes had to be as short as possible. Yet, if the spokes were too short, the substrate supporting the fuse could not withstand sufficient voltage. The final design employing 4.5-cm-long spokes was settled on as a reasonable compromise, even though the field strength along the surface of the insulator was expected to exceed 300 kV/cm. Measures were taken to reduce the

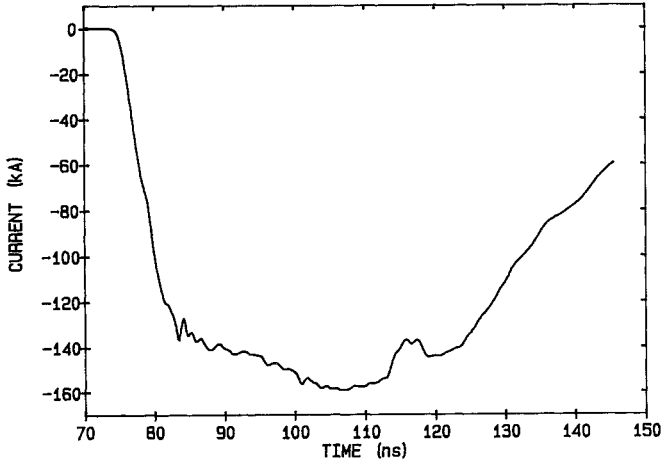

Figure 4. Input current to the 16-spoke fuse.

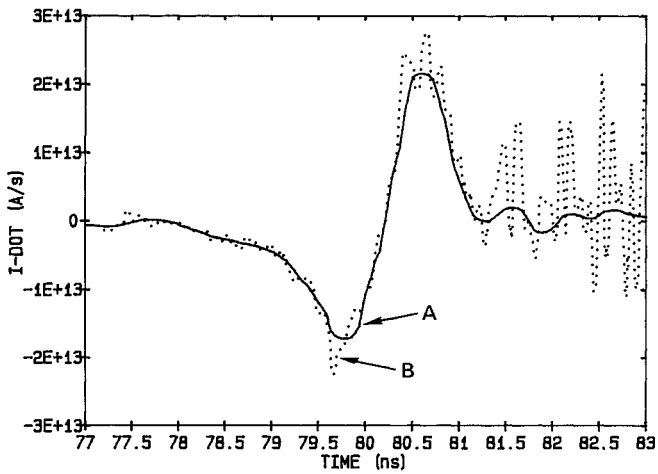

Figure 5. Output I-dot measured behind the 16-spoke fuse.
A) B-dot probe measurement (TEK 7104)
B) B-dot probe measurement (TEK 7250)

recorded on the 1-GHz TEK 7104. As of yet, we are uncertain whether the high frequency signals result from the dynamics of the plasma from the exploded foil or whether they result from a resonance in the geometry of the apparatus.

Integrating waveforms "A" and "B" in Fig. 5 and scaling by a factor of 41.6 results in the output voltage waveforms "A" and "B" shown in Fig. 6. This factor of 41.6 is the value of the VITL impedance only for the round trip time of 7 ns that it takes for the output pulse to encounter and reflect back from the shorted end of the VITL. Also shown in Fig. 6 as waveform "C" is the voltage obtained by scaling the current measured by a CVR located on the VITL several inches behind the fuse (and recorded on a TEK 7104 oscilloscope). The peak output voltage ranges from 590 kV to 700 kV, depending on the type of sensor and recording instrument used. The full-width-half-maximum (FWHM) of the voltage pulse is on the order of 1.1 ns.

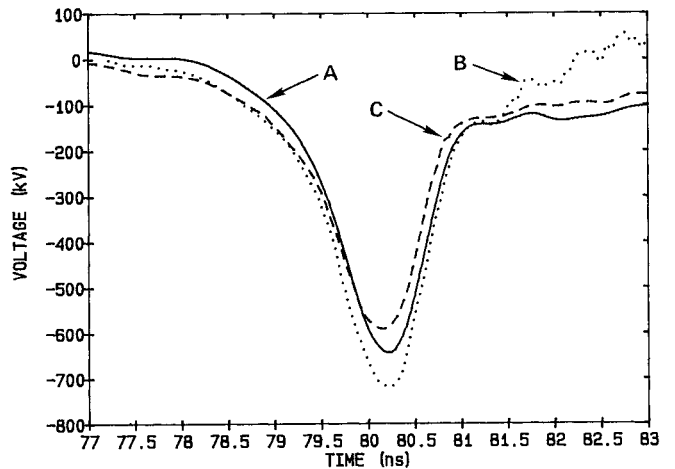

Figure 6. Output voltage measured behind the 16-spoke fuse.
A) B-dot probe measurement (TEK 7104)
B) B-dot probe measurement (TEK 7250)
C) CVR measurement (TEK 7104)

Table 1. Effect of fuse parameter variation on fuse performance.

PARAMETER VARIED	PEAK OUTPUT VOLTAGE	FWHM OF OUTPUT VOLTAGE PULSE	BURST TIME OF FUSE
Al Coating Thickness	decreases with increasing Al coating thickness	increases with increasing Al coating thickness	increases with increasing Al coating thickness
Number of Spokes	increases slightly with increasing number of spokes	increases slightly with increasing number of spokes	increases slightly with increasing number of spokes
Tamper Thickness	increases slightly with increasing tamper thickness	no apparent trend	no apparent trend
Fabrication Technique	no effect	no effect	no effect

likelihood of surface flashover by shaping the E-field to intercept the insulator at 45 degrees and by anodizing the field emitting surface.

The experimental results indicate the substrate supporting the fuse did flash over, limiting the output voltage to approximately 700 kV. This was less than half the expected voltage level based on modeling the fuse bursting action. Most of the fuses that were tested produced similar output voltages with little variation in amplitude or pulse shape. In fact, with an uncoated kapton disk inserted in place of the fuse, the output was similar in amplitude to results from a typical fuse. Fig. 7 compares the output voltage pulse from a typical fuse (8-spoke, 0.25- μ m-thick aluminum on 5-mil-thick kapton, with a Fixatif spray tamper) and a plain 5-mil-thick kapton disk as waveforms "A" and "B", respectively. The similar output voltage pulse shapes provided initial evidence that flashover along the surface of the kapton was shorting out the voltage pulse. Further evidence of flashover was obtained using an optical streak camera viewing the insulator during a shot with a plain kapton disk. The streak camera recorded a significant amount of optical emission at the same time the

voltage pulse was launched down the VITL. In an attempt to increase the voltage holdoff level, the surface path length was increased by attaching a 0.64-cm-high, 0.13-cm-thick acrylic ring to each side of a 5-mil-thick kapton disk using an epoxy bond. Waveform "C" in Fig. 7 shows the resulting output voltage pulse. Even though the surface path length was increased by 1.41 cm, there was little improvement in voltage holdoff. Optical microscopy revealed treeing structure through the epoxy material providing further evidence that a discharge was occurring across the insulator surface.

Conclusions

These experiments have demonstrated that very thin metallic foils can behave as fast-acting fuses on nanosecond timescales. The bursting action of the exploding foil produces a very fast rise time, gaussian-like voltage pulse. Fuse performance was enhanced by increasing the number of spokes and decreasing the thickness of the metal coating. Peak voltages of up to 700 kV were obtained with pulse widths as narrow as 1.1 ns FWHM. The usefulness of such a device seems limited by the practical need to support the thin foils with an insulating substrate. While our experimental setup had several limitations imposed in order to make use of available hardware, the concept could be useful in certain applications, and better performance could be expected from a design that was optimized.

References

- [1] J. V. Parker and W. M. Parsons, "Foil Fuses as Opening Switches for Slow Discharge Circuits," Proceedings of the 5th IEEE Pulsed Power Conf. (Arlington, VA), 1985, pp. 283-286.
- [2] J. N. DiMarco and L. C. Burkhardt, "Characteristics of a Magnetic Energy Storage System Using Exploding Foils," Journal of Applied Physics, vol. 41(9), pp. 3894-3899, August 1970.
- [3] R. E. Reinovsky and W. L. Baker, "Shiva Star Inductive Pulse Compression System," Proceedings of the 4th IEEE Pulsed Power Conf. (Albuquerque, NM), 1983, pp. 196-201.

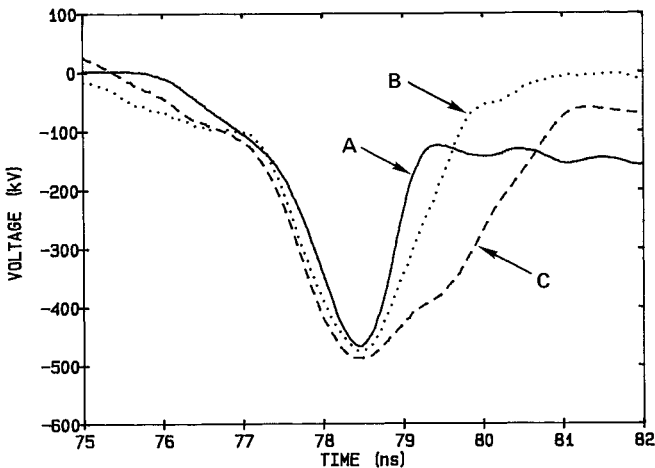

Figure 7. Comparison of a CVR (TEK 7912AD) measurement for: A) Typical 8-spoke fuse, B) Plain kapton disk, C) Kapton disk with acrylic rings. Waveforms "B" and "C" have been shifted along the time axis in order to align their peak voltages to that of waveform "A".