

50-kA COAXIAL ORIENTATION INDEPENDENT IGNITRON

R.L. Poeschel, D.M. Goebel, J.G. Elverum, and R.G. Fleig

Hughes Research Laboratories
3011 Malibu Canyon Road
Malibu, CA 90265

B. Long* and H. Rhinehart**
Pulsed Power Center
U.S. Army Research Laboratory
Fort Monmouth, NJ 07703-5601

Abstract

The Orientation Independent Ignitron (OII) switch provides the same electrical function as a conventional mercury pool ignitron, but maintains the mercury wetted to a molybdenum cathode surface, and is thereby independent of the switch orientation. Hughes is developing a coaxial OII switch configuration with nominal ratings of 50 kA and 25 kV to evaluate its potential use in electric-gun power modulators. The ratings for peak current and Coulomb transfer of the OII switch depend on the design of the cathode and the quantity of mercury that can be maintained on the wetted surface. Repetition rate is governed by the thermal control employed. Design criteria for achieving requirements on peak current, Coulomb transfer and repetition frequency have been reported previously.¹ This paper describes our most recent experiments for assessing switch performance and electrode wear as a function of the OII switch operating conditions. Experiments were performed with a prototype switch that was designed to permit partial disassembly and reprocessing. Test results are compared with design projections, and prospects for scaling to higher current, larger coulomb transfer and/or higher repetition rates are discussed.

Introduction and Summary

The Orientation-Independent Ignitron (OII) has been under development at Hughes Research Laboratories for application in systems where the gravity dependence of an ordinary liquid-mercury-pool-cathode ignitron closing switch is not acceptable. In the OII switch, the liquid mercury pool is kept in place on the cathode by adhesion and surface tension, and is therefore independent of the orientation of the switch relative to gravitational forces. During operation, mercury is vaporized by the arc spot and leaves the cathode; however, the cathode and other internal switch surfaces are temperature-controlled to force recondensation of the mercury vapor on the cathode. Several experimental OII switches were built and tested under Government contracts^{1,2} to demonstrate OII capabilities. The OII switch performance demonstrated in tests at HRL and Pulsed Power Center at the U.S. Army Research Laboratories is unequalled by any other switch technology. The switch hardware developed has been designed primarily for experimentation, and design modifications are being developed to bring the status of OII switch technology to a point where it is a viable candidate for use in the Army's electric gun program.

This paper describes the progress of recent work³ that is focused on simplifying the design of the previously tested OII switch, without degrading its performance capabilities. We assembled a new switch based on our design modifications to determine whether the simplifications produced any loss of capability. Initial tests were performed at HRL and the switch was delivered to Pulsed Power Center for further evaluation.

* Now with Parker Kinetics, Dover NJ

** Now with Instrument Research Co., Columbia, MD

Recent improvements to the OII switch include the following significant features:

- The switch is a sealed-off unit. A zirconium getter is used to maintain vacuum.
- Only the cathode requires cooling (0° to 5°C).
- All heaters are commercial-type, clamp-on heaters.
- Igniters require no heating or cooling.
- The voltage hold-off is 25 kV with appropriate thermal control and conditioning.
- Electrode materials are selected for compatibility with mercury (negligible amalgamation).

Switch performance characteristics are considered to be the same as those demonstrated previously, although recent testing has been very limited in scope. The switches have removable vacuum flanges to permit inspection of the electrodes after testing, and tests were performed with several interruptions for inspecting the electrode condition. Testing in a circuit that prevents current ringing at 15-kA peak current produced no measurable electrode damage or wear. Testing at higher currents up to 50 kA was invalidated by crowbar circuit misfiring, which permitted current reversal and ringing. Although the switch function was not impaired, electrode damage was discovered after the high-current tests when the switch was opened for inspection. Consequently, it is now apparent that OII switches require a circuit that prevents significant current reversal if long lifetime is to be obtained at high currents.

Technical Discussion

The OII switch design eliminates the liquid mercury pool used in standard ignitrons by providing "pool-keeping" structures in the switch. This concept takes the form of shallow grooves in a molybdenum cathode surface. The mercury is wetted into these grooves, and the arc discharge is anchored at the mercury-molybdenum interface. We refer to this interface between the liquid mercury in the groove and the metal surface as the "beach." The OII switch discussed here has electrodes configured in a coaxial, cylindrical geometry. The outer cylinder is the cathode, and the pool-keeping grooves are machined on the inside surface of the cathode electrode. A cylindrical anode is located inside the cathode and supported by a ceramic bushing. The basic geometry of the coaxial OII is shown in Figure 1.

The peak current of the switch is determined to first order by the size and number of grooves (length of beach) in the switch, and to second order by the dynamic forces on the arc and plasma in the switch during conduction. During conduction, the mercury in the grooves is expelled from the arc-spots as vapor into the switch volume. The cathode is maintained at a significantly lower temperature (0 to 5°C) than all of the other interior switch surfaces (maintained at about 100°C). Between current pulses, the mercury re-condenses on the cathode surfaces and is drawn into the grooves by adhesion and surface tension.

Report Documentation Page

Form Approved
OMB No. 0704-0188

Public reporting burden for the collection of information is estimated to average 1 hour per response, including the time for reviewing instructions, searching existing data sources, gathering and maintaining the data needed, and completing and reviewing the collection of information. Send comments regarding this burden estimate or any other aspect of this collection of information, including suggestions for reducing this burden, to Washington Headquarters Services, Directorate for Information Operations and Reports, 1215 Jefferson Davis Highway, Suite 1204, Arlington VA 22202-4302. Respondents should be aware that notwithstanding any other provision of law, no person shall be subject to a penalty for failing to comply with a collection of information if it does not display a currently valid OMB control number.

1. REPORT DATE JUN 1993	2. REPORT TYPE N/A	3. DATES COVERED -			
4. TITLE AND SUBTITLE 50-Ka Coaxial Orientation Independent Ignitron		5a. CONTRACT NUMBER			
		5b. GRANT NUMBER			
		5c. PROGRAM ELEMENT NUMBER			
6. AUTHOR(S)		5d. PROJECT NUMBER			
		5e. TASK NUMBER			
		5f. WORK UNIT NUMBER			
7. PERFORMING ORGANIZATION NAME(S) AND ADDRESS(ES) Hughes Research Laboratories 3011 Malibu Canyon Road Malibu, CA 90265		8. PERFORMING ORGANIZATION REPORT NUMBER			
9. SPONSORING/MONITORING AGENCY NAME(S) AND ADDRESS(ES)		10. SPONSOR/MONITOR'S ACRONYM(S)			
		11. SPONSOR/MONITOR'S REPORT NUMBER(S)			
12. DISTRIBUTION/AVAILABILITY STATEMENT Approved for public release, distribution unlimited					
13. SUPPLEMENTARY NOTES See also ADM002371. 2013 IEEE Pulsed Power Conference, Digest of Technical Papers 1976-2013, and Abstracts of the 2013 IEEE International Conference on Plasma Science. Held in San Francisco, CA on 16-21 June 2013. U.S. Government or Federal Purpose Rights License.					
14. ABSTRACT The Orientation Independent Ignitron (011) switch provides the same electrical function as a conventional mercury pool ignitron, but maintains the mercury wetted to a molybdenum cathode surface, and is thereby independent of the switch orientation. Hughes is developing a coaxial 011 switch configuration with nominal ratings of 50 kA and 25 kV to evaluate its potential use in electric-gun power modulators. The ratings for peak current and Coulomb transfer of the 011 switch depend on the design of the cathode and the quantity of mercury that can be maintained on the wetted surface. Repetition rate is governed by the thermal control employed. Design criteria for achieving requirements on peak current, Coulomb transfer and repetition frequency have been reported previously. This paper describes our most recent experiments for assessing switch performance and electrode wear as a function of the 011 switch operating conditions. Experiments were performed with a prototype switch that was designed to permit partial disassembly and reprocessing. Test results are compared with design projections, and prospects for scaling to higher current, larger coulomb transfer and/or higher repetition rates are discussed.					
15. SUBJECT TERMS					
16. SECURITY CLASSIFICATION OF:			17. LIMITATION OF ABSTRACT SAR	18. NUMBER OF PAGES 4	19a. NAME OF RESPONSIBLE PERSON
a. REPORT unclassified	b. ABSTRACT unclassified	c. THIS PAGE unclassified			

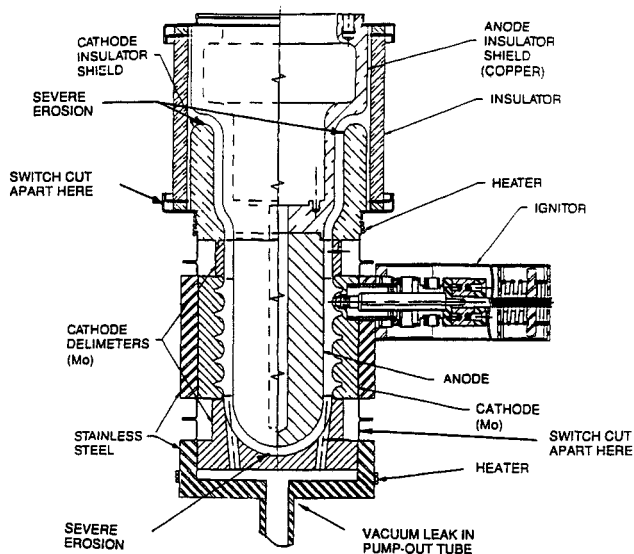

Figure 1. Cross-section of Switch No. 1 before modification.

The switch is closed or ignited by producing a small arc between a semiconductor igniter (usually boron carbide) and the mercury-wetted molybdenum cathode. The ignited switch discharge then transitions to a mercury arc with anchored spots running on the groove beaches. The voltage drop across the arc can be as low as 10 V; however, the electrode resistance increases the switch forward voltage drop to about 20 V at high peak currents. Theoretically, OII switches should be capable of very high Coulomb transfer because there are no wearout mechanisms. However, there appear to be practical and operational limitations that we have only begun to identify.

We began this present investigation with disassembly and inspection of an OII switch² that was built earlier by HRL and tested extensively at Pulsed Power Center. This switch was initially thought to have been a virtually new condition, except that it had ceased functioning because of loss of vacuum; however, upon disassembly of the switch, we discovered unanticipated electrode damage. The initial configuration of the switch is shown in Figure 1, with the points of disassembly and observed damage noted. Photographs of the damaged regions are shown as Figures 2 and 3, and the analysis of the observed damage is summarized in Table 1. All the operational history of the switch was not available, and therefore it was not possible to determine whether the switch damage shown had occurred because of improper operational procedures, or because of an unexpected design inadequacy. It appears, however, that the current in the switch had not been constrained to the region defined by the mercury-wetted cathode grooves.

After appraising the electrode conditions found in the switch, we considered it essential to modify the hardware to address possible causes of the observed damage and to perform some definitive experiments to determine whether electrode damage occurs when the switch is operated under carefully controlled conditions. The modified switch design is shown schematically in Figure 4; noteworthy features are:

- Use of molybdenum for the cathode insulator shield (Paschen shield).
- Elimination of copper electrodes to avoid possible amalgamation and subsequent mercury loss or arc initiation outside the cathode region.
- Elimination of apertures in the lower cathode delimiter to improve voltage hold-off capability and prevent "hollow cathode" discharge formation.
- Use of sealed-off vacuum envelope with zirconium-getter pumping.
- Use of flanges to accommodate disassembly and inspection after operation.

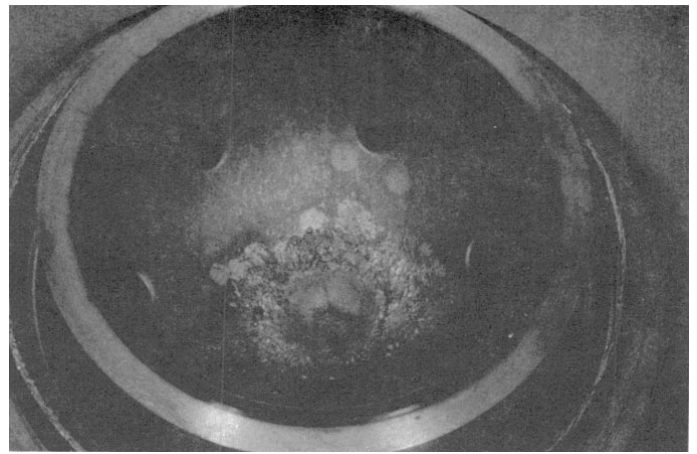

Figure 2. Photograph of lower cathode delimiter showing electrode damage.

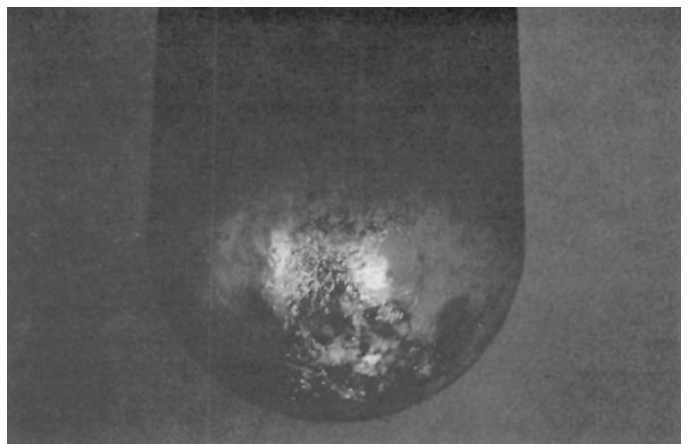

Figure 3. Photograph of lower end of anode showing electrode damage.

TABLE 1. Summary of OII Damage Analysis.

1. OII switch No. 1 was damaged to a greater extent than would be anticipated on the basis of the operating history: <ul style="list-style-type: none"> • Evidence of anode arc spots. • Evidence of cathode delimiter arc spots, located primarily at the bottom of the switch and facing the most severe of the anode melting and arc spots.
2. Operational requirements on temperature and vacuum may have been sufficiently compromised during switch operation to explain the observed damage: <ul style="list-style-type: none"> • Damage may have occurred after a heater failure at Pulsed Power Center if cathode was not sufficiently re-processed to return the mercury properly to the cathode surface. • Mercury coverage of the cathode may have been inadequate because mercury was lost due to vacuum leaks, amalgamation with improper materials, and subsequent repairs.
3. The coaxial switch configuration may be vulnerable to metal-arc damage because J X B force may cause arc current to transfer to bottom of switch.
4. Arc discharge on the mercury-covered cathode may "run dry" because the mercury fill is depleted by amalgamation with non-active switch surfaces.

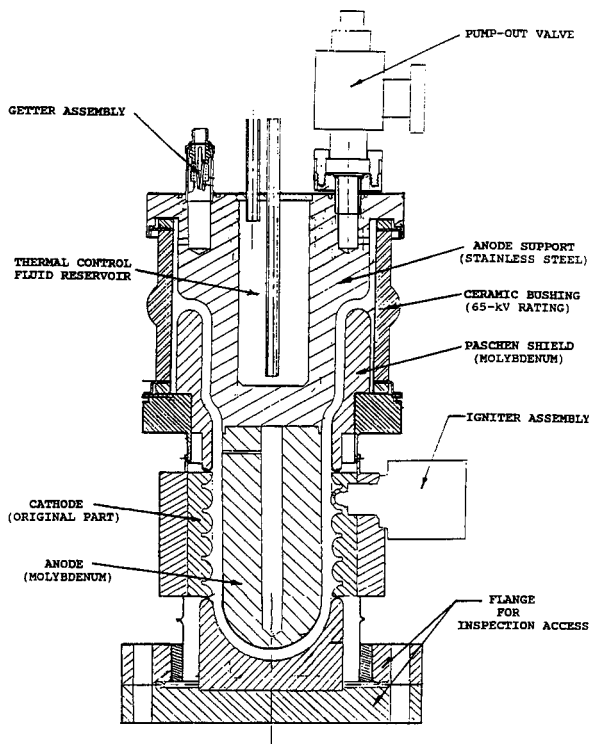

Figure 4. Cross-section drawing of Switch No. 1 showing modifications for the hardware.

The switch was assembled, processed as a vacuum tube, and then loaded with mercury. Initial testing was performed using the circuit shown in Figure 5. The switch was operated at 0.1 Hz to 0.2 Hz, starting at a capacitor-charging voltage of 5 kV and increasing the voltage to 11 kV, which produced peak currents of 11 kA to 15 kA; typical waveforms are shown in Figure 6. We completed the initial series of tests, accumulating about 3,000 pulses at peak currents in the 11 kA to 15 kA range. At this point, we disassembled the switch and inspected the switch electrodes. Our major observations are:

- No electrode damage, or appreciable electrode marking occurred in the initial tests.
- Mercury was not found on any electrode surface except the cathode.
- Mercury was contained primarily in the cathode grooves, but mostly as small droplets, and not as a continuous, wetted meniscus (at least, when inspected in air).
- There was no evidence of igniter damage.

These observations provided positive evidence that the switch current is conducted by arc formation on the mercury in the cathode grooves in deference to arc formation on other cathode-potential molybdenum surfaces (as was apparent in the initial disassembly of the switch). It is noteworthy that for this series of tests, temperatures of the cathode and other electrodes were always maintained at appropriate relative temperatures to keep the mercury condensed on the cathode. The cathode temperature was maintained in the 2° to 10°C range, and all other electrodes were heated to 90°C or higher.

Measurement of the igniter temperature in this experiment showed that the igniter tip remains at a constant temperature relative to the cathode temperature without active cooling or heating (approximately 10°C above the cathode temperature). This differential in temperature was relatively insensitive to whether or not the igniter had been in operation. Consequently, we conclude that for switches operated at low repetition rate, active igniter heating or cooling is not required, and the igniter design can be simplified. The simplified igniter design is shown in Figure 7 and the noteworthy features are as follows:

- Shorter in length, more compact.
- Uses commercial ceramic feedthrough.
- Pressure adjustment mechanism is eliminated.

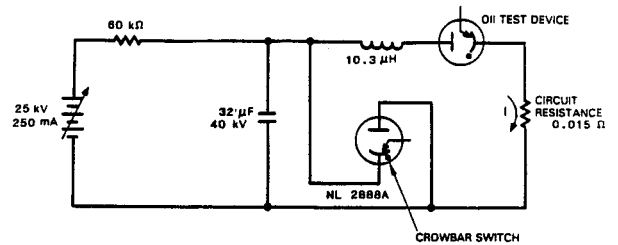

Figure 5. Major components of OII test circuits for initial testing at 10 to 15 kA peak current.

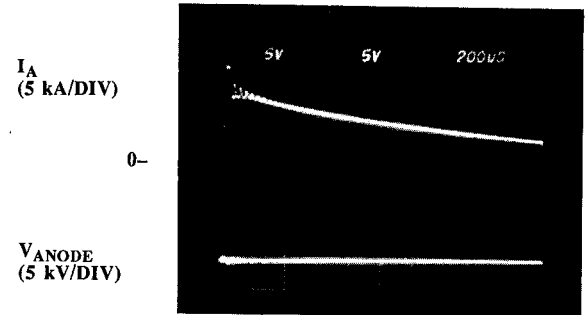

Figure 6. Current and anode voltage waveforms for initial switch tests.

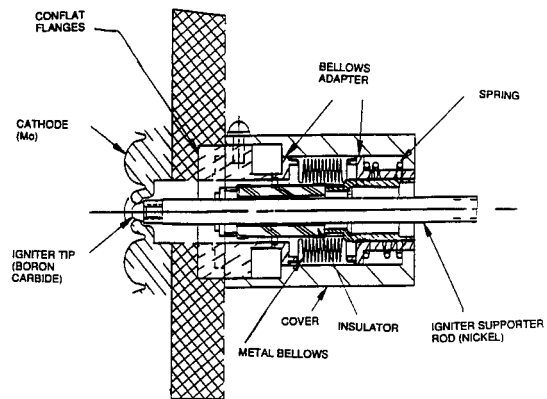

Figure 7. Simplified igniter design.

A photograph of the simplified OII switch is shown as Figure 8.

After completion of the initial tests, we reassembled, reprocessed, and retested the switch using the circuit of Figure 5 with the energy-storage capacitor increased to 192 μ F. We achieved 50-kA peak current with the charging supply adjusted to 12 kV and repetition rate kept at 0.03 Hz or less. We logged approximately 250 pulses at 50-kA peak current, and more than 1000 pulses at currents greater than 25 kA, but difficulties were experienced with the crowbar circuit during testing at currents greater than 30 kA. Sporadic misfiring of the crowbar ignitron permitted current reversal in the OII switch, resulting in current ringing at nearly the full peak value. We were not successful in eliminating crowbar misfires during these tests, and consequently we terminated testing and opened the switch for inspection of the electrodes.

Inspection of the OII electrodes after the 50-kA test sequence disclosed severe electrode damage to the lower cathode delimiter and the anode (similar to that shown earlier in Figures 2 and 3 as for the initial examination of the OII switch). The damage was, in fact, more severe, but was limited to these two electrodes. We attribute the observed anode damage to current reversal in the switch.

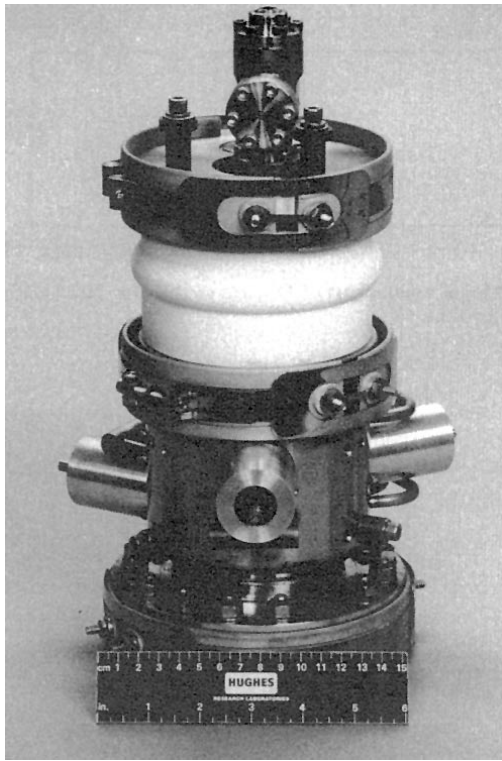

Figure 8. Photograph of Switch No. 2 ready for delivery.

Current reversal and ringing forces the anode to form an arc spot, vaporizing metal instead of mercury and initiating a sustained metal vapor arc between the anode and the cathode delimiter. We evaluated the use of graphite as a delimiter material with the goal of quenching reverse current; however, the arc appears to transition to a carbon arc on the lower delimiter surface even without current reversal. Consequently, we still have to verify long life operation at the 50 kA rating in a circuit that protects against current reversal, or is critically damped.

Conclusions

The OII switch discussed here has been shown to operate reliably and with long-life capability when operated in the 20- to 30-kA current range. Operation in a circuit that causes current reversal damages the switch. The switch can readily achieve the 50-kA peak current rating; however, long-life operation of the switch at 50 kA remains to be verified.

References

1. W.O. Eckhardt, H.E. Gallagher, R.G. Fleig, "Orientation-independent ignitron with grooved cathode," US Patent No. 4,970,440, November 1990.
2. W.O. Eckhardt et al., "Orientation-independent ignitron high power closing switch," Final Technical Report to Defense Nuclear Agency for Contract DNA 001-87-C-0089, February 1990.
3. R.L. Poeschel and D.M. Goebel, "Tactical Megawatt Electronics," Final Technical Report to US Army Research Laboratory for Contract DAAL01-91-C-0150, October 1992.