

# A VERSATILE, MODULAR CAPACITOR BANK FOR A COMPACT ACCELERATOR

R. Curry, V. Bailey, D. Nett, S. Putnam,  
M. Tiefenback, S. Lyons, W. Weseloh

PULSE SCIENCES, INC.  
600 McCormick Street  
San Leandro, CA 94577

## Abstract

The spiral line recirculating induction accelerator (SLIA) is a compact, lightweight electron accelerator, designed to produce high current ( $\geq 1$  kA), high energy ( $\geq 50$  MeV) and moderate to high quality electron beams with macropulse widths up to several microseconds. The SLIA is an open-ended spiral configuration in which the electron beam recirculates in separate transport lines ( $\leq 20$ ) passing through a common ferrite core accelerating section with high gain/pass ( $\sim 10$  MeV), resulting in effective accelerating gradients in the 100 MV/m range. A toroidal field threads the transport lines for space charge confinement and suppression of instabilities. In the bends, a vertical field turns the beam and a strong focussing field ( $\ell = 2$  stellarator) provides tolerance to field errors and an energy bandwidth desirable with high gain/pass. The magnetic fields throughout the transport system are static over the beam macropulse thus allowing very low field errors and precise control of the magnetic fields.

A Phase I experimental and theoretical program is now underway at PSI to investigate key physics issues regarding energy bandwidth, control of emittance growth and electromagnetic instabilities. General purpose low voltage, modular capacitor banks consisting of twenty-four 1.4 mF, 450 V electrolytic capacitors were chosen as the energy source for the magnet coils. Low voltage banks avoid insulation problems with the small spacings required between the various coil windings in the SLIA. With minor modifications, the capacitor banks can be connected in parallel or series to accommodate the widely varying inductances and resistances encountered in the experiments. The bank design is based on discharge current and voltage reversal characteristics determined in tests performed at PSI on electrolytic capacitors. Designed around the state-of-the-art power semiconductors (SCR's and diodes), the banks are easily serviceable and inexpensive to construct.

The design for the capacitor control/data acquisition system and the nine capacitor banks required for the Phase I experiments are presented. Test data to date is presented on the capacitor bank design, and the applicability of computer controlled capacitor banks to compact accelerator concepts is discussed. Cost data and reliability of the banks is also reported.

## INTRODUCTION

The ongoing Phase I program consists of a  $180^\circ$  beam bending and transport experiment.<sup>1,2</sup> A nominal 1 MeV, 1 kA, 100 ns electron beam is injected into a 3.6 m transport line with a  $180^\circ$  bend radius of 0.5 m. The program is intended to provide the information required for scaling to a multipass induction cavity experiment (3 pass with 3 MV/pass in Phase II).

\*Work supported by SDIO/IST and managed by Office of Naval Research.

Stellarator, guide/toroidal, matching and vertical field coils are required to extract, transport, and bend the beam. Nominal magnetic field amplitudes are 5 kG for the guide/toroidal, 2.5 kG for the matching, and 100 G (Phase I) to 500 G (Phase II experiments) for the vertical field. The on-axis quadrupole field gradient is 525 G/cm. The field winding inductances, resistances, and currents range from 23.5  $\mu$ H to 270  $\mu$ H, 0.020  $\Omega$  to 0.057  $\Omega$ , and 500 A to 7 kA respectively. Precise control of the magnetic fields is required to avoid field mismatches which lead to emittance growth and loss of beam electrons.

## MODULAR BANK DESIGN

Nine capacitor banks (fifteen modules total) are required for the Phase I experiments. There are a total of fourteen field winding configurations in the experimental transport system. General purpose 450 V, 3.4 kJ capacitor bank modules have been developed to meet this wide range of circuit parameters. Traditional designs for capacitor banks have conservatively tailored each capacitor bank to its particular load. Ultimately this results in high design and fabrication costs, with banks limited to one type of load. New state-of-the-art high voltage diodes and SCR's allow versatile banks to be easily designed and built. Based upon preliminary high current tests performed at PSI, a versatile design for a high current SCR switched capacitor bank is presented. Designed to operate as an individual capacitor bank or in series or parallel, the module has been designed for 30 kA peak current operation. Operated in series, the capacitor bank modules has been tested reliably at peak currents of 15 kA (10-90% current risetime of 312  $\mu$ s). The final bank design is modular allowing easy construction. The modules are fully protected and will operate at up to 40% voltage reversal.

The magnet windings require small spacings to avoid excessive drive currents. Thus to avoid insulation problems, voltages below 2 kV were necessary. Electrolytic banks were selected because of their low voltage characteristics to meet these requirements. In addition, electrolytic banks are well documented and their operating characteristics do not degrade for 5-10 years.<sup>3,4</sup>

Commercial electrolytics presently have a relatively high energy density of about 141 J/lb and research indicates that energy densities greater than 3500 J/lb are possible for mobile or space based systems of the future. Electrolytics are also applicable to repetitive systems which operate at tens of pulses per second. Present cost of about 9 cents per joule coupled with their high energy density make them attractive as an alternative to high voltage capacitor banks.

The final capacitor bank module incorporates 24 each, 1.4 mF, 450 V capacitors (Sprague 36 Dx) (Figure 1). Although larger capacitors are currently available, design tradeoffs show that under normal operation the peak operational current should be kept below 300 A per capacitor. Although the initial Phase I experiments will be conducted at low rates of

## Report Documentation Page

*Form Approved*  
*OMB No. 0704-0188*

Public reporting burden for the collection of information is estimated to average 1 hour per response, including the time for reviewing instructions, searching existing data sources, gathering and maintaining the data needed, and completing and reviewing the collection of information. Send comments regarding this burden estimate or any other aspect of this collection of information, including suggestions for reducing this burden, to Washington Headquarters Services, Directorate for Information Operations and Reports, 1215 Jefferson Davis Highway, Suite 1204, Arlington VA 22202-4302. Respondents should be aware that notwithstanding any other provision of law, no person shall be subject to a penalty for failing to comply with a collection of information if it does not display a currently valid OMB control number.

1. REPORT DATE <b>JUN 1987</b>	2. REPORT TYPE <b>N/A</b>	3. DATES COVERED <b>-</b>			
4. TITLE AND SUBTITLE <b>A Versatile, Modular Capacitor Bank For A Compact Accelerator</b>		5a. CONTRACT NUMBER			
		5b. GRANT NUMBER			
		5c. PROGRAM ELEMENT NUMBER			
6. AUTHOR(S)		5d. PROJECT NUMBER			
		5e. TASK NUMBER			
		5f. WORK UNIT NUMBER			
7. PERFORMING ORGANIZATION NAME(S) AND ADDRESS(ES) <b>PULSE SCIENCES, INC. 600 McCormick Street San Leandro, CA 94577</b>		8. PERFORMING ORGANIZATION REPORT NUMBER			
9. SPONSORING/MONITORING AGENCY NAME(S) AND ADDRESS(ES)		10. SPONSOR/MONITOR'S ACRONYM(S)			
		11. SPONSOR/MONITOR'S REPORT NUMBER(S)			
12. DISTRIBUTION/AVAILABILITY STATEMENT <b>Approved for public release, distribution unlimited</b>					
13. SUPPLEMENTARY NOTES <b>See also ADM002371. 2013 IEEE Pulsed Power Conference, Digest of Technical Papers 1976-2013, and Abstracts of the 2013 IEEE International Conference on Plasma Science. Held in San Francisco, CA on 16-21 June 2013. U.S. Government or Federal Purpose Rights License</b>					
14. ABSTRACT <b>The spiral line recirculating induction accelerator (SLIA) is a compact, lightweight electron accelerator, designed to produce high current (~ 1 kA), high energy (~ 50 MeV) and moderate-to-high quality electron beams with macropulse widths up to several microseconds. The SLIA is an openjended spiral configuration in which the electron beam recirculates in separate transport lines (~ 20) passing through a common ferrite core accelerating section with high gain/pass (- 10 MeV), resulting in effective accelerating gradients in the 100 MV/m range. A toroidal field threads the transport lines for space charge confinement and suppression of instabilities. In the bends, a vertical field turns the beam and a strong focussing field (~ = 2 stellarator) provides tolerance to field errors and an energy bandwidth desirable with high gain/pass. The magnetic fields throughout the transport system are static over the beam macropulse thus allowing very low field errors and precise control of the magnetic fields.</b>					
15. SUBJECT TERMS					
16. SECURITY CLASSIFICATION OF:			17. LIMITATION OF ABSTRACT <b>SAR</b>	18. NUMBER OF PAGES <b>4</b>	19a. NAME OF RESPONSIBLE PERSON
a. REPORT <b>unclassified</b>	b. ABSTRACT <b>unclassified</b>	c. THIS PAGE <b>unclassified</b>			

approximately one shot every 10 minutes, eventual upgrade to much higher rep-rates may be required. Internal dissipation of less than  $10^{20}$  W per capacitor is required for long lifetime and reliable operation. In addition, the  $96 \text{ m}\Omega$  internal resistance of each capacitor requires a large number of capacitors to keep the total output resistance of each capacitor bank module below  $5 \text{ m}\Omega$ .

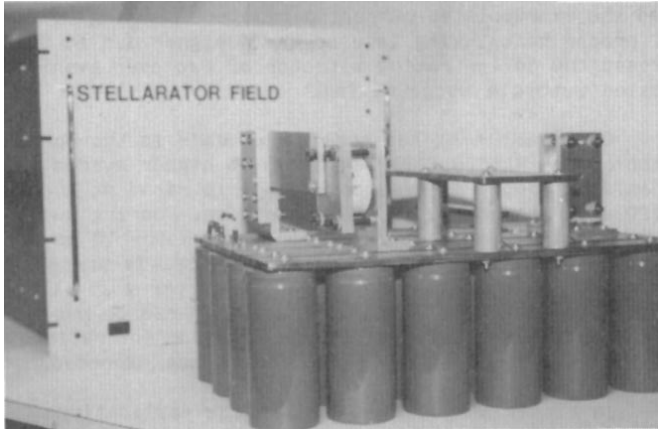

Figure 1. Photo of one bank module before final chassis assembly.

The final bank module design along with protection circuits is shown in Figure 2. The capacitor banks are self-contained except for power supplies. Protection circuits along with trigger circuits, voltage and current monitors are also included in the design. The module is switched by a Phase Control SCR, WESTCODE P300CH12F2K0. Free wheeling high current diodes, WESTCODE SW12CX805, are used to limit voltage reversal across the capacitors. Even though voltage reversal does not seem to significantly affect the lifetime of the bank under short term tests, an operational lifetime of five years is required. Thus inexpensive protection in the form of free wheeling diodes has been designed into the banks.

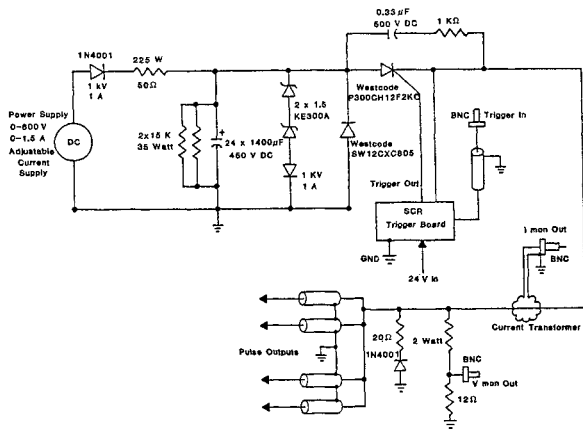

Figure 2. Schematic of capacitor bank module configured for independent operation.

To prevent large overvoltage of the banks, the voltage across the capacitors is limited to 600 V by high current, fast turn-on transzorbs (General Semiconductor 1.5KE300A). To prevent transients from damaging the power supply, a diode (1N4001) and a 50  $\Omega$  wire wound resistor in series with the charging path was designed into the circuit. Note that the resistor does not provide current limiting, rather the power supplies can be programmed to limit the charging current. Under normal operation in the Phase I experi-

ments, the banks will only be required to supply about 7500 A. However, future experiments may require operating currents in excess of 15 kA. Thus all components have been conservatively selected to reduce premature failure, and insure reliable SCR triggering even under high current operation and fast risetime operation. To facilitate fast, reliable turn on of the SCR, a 300 ns risetime ( $10^{10}$ ) 6 V gate pulse is used to trigger the SCR. The gate pulse is maintained for about 8  $\mu\text{s}$ .

Electrolytic capacitor banks unfortunately have one disadvantage. Because of their high output capacitance their current risetime into even the moderate field winding inductances is severely limited. The current risetime can be reduced either by reducing the winding inductances or by reducing the capacitance of the electrolytic banks and increasing their operating voltage. Series operation (charging) is well known for increasing the risetime and voltage output of electrolytic banks. In order to avoid designing and constructing different types of banks, the design developed allows for series operation of banks with only very minor modifications.

The capacitor bank modules are built in modular form, Figure 1, and then installed into a chassis. Each module is floated in the chassis using G#10 sheets. This allows either single point grounding or floating of the module inside the chassis with the simple removal of a bracket. The banks can then be connected in series to accommodate the wide variation of circuit parameters. Note that additional surge protection, series resistance in the free wheeling diode circuit and charging path circuits are required for series operation (Figure 3). The surge protection is required for SCR. In case of a fault, the final output SCR could easily be overvoltaged. The transzorbs placed across the SCR prevent damage by clamping the voltage across the SCR. A 100  $\mu\text{H}$  high current inductor along with a 20  $\Omega$  resistance is added to provide a charging path for the floated bank. Additionally, the inductor/resistor combination provides a holding current path for the grounded bank's SCR. The grounded banks output switch (SCR) may fire before the series bank (in a fault). If a current path is not provided, the SCR would shut off prematurely creating additional faults.

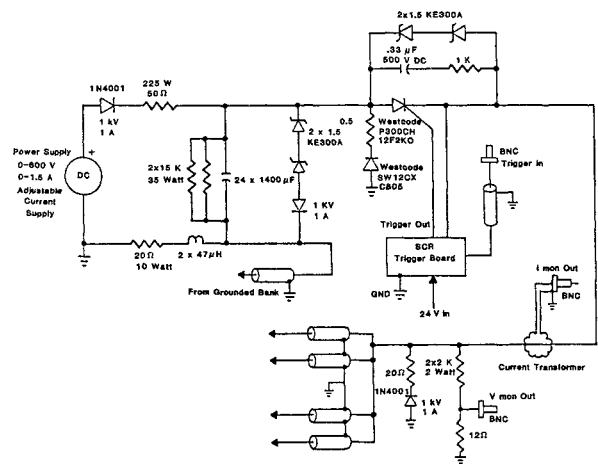

Figure 3. Schematic of capacitor bank module configured for SERIES OPERATION.

Series operation of high current electrolytic banks has several implications. Series operation of 450 V, electrolytic banks allow presently available 1 $\frac{1}{2}$  2 kV solid state switches to be used as a replacement for ignitrons. This affords longer lifetime and lower

maintenance capacitor banks. Note that series operation of the modules is not limited to two. The trigger electronics provide 5 kV isolated triggers, thus allowing seriesing of up to ten banks, with several minor component changes.

### HIGH CURRENT OPERATION OF ELECTROLYTICS

Two experiments performed at PSI showed that presently available electrolytics are able to operate under high current discharge conditions and voltage reversal. The first test utilized in-house 2.1 mF, 300 VDC (Sprague 360 Dx) electrolytics, similar to the capacitor used in the final capacitor banks.

The 2.1 mF capacitor was first formed by slowly raising the charge voltage over 5 minutes to 300 VDC. The full voltage was then left on the capacitor for 10 minutes. Leakage currents after forming were reduced to below 1 mA levels. After conditioning, the capacitor was discharged into a 12  $\mu$ H, 157 m $\Omega$  load.

Even after 100 shots at risetimes to peak of 200  $\mu$ s and peak currents of 3300 A through an individual capacitor, the test capacitors showed no degradation. Previous literature had reported similar results using electrolytics manufactured in the 1960's.<sup>5</sup> A second set of tests using the 2.1 mF capacitors electrolytics was devised to assess the impact of current and voltage reversal. After forming, a 2.1 mF capacitor was discharged into a 3 m $\Omega$ , 12  $\mu$ H load. Current reversals of 20% were noted. However no sign of degradation was noted even after 20 test shots. Reported tests on similar electrolytics had shown that voltage (pulse) reversals of 50-60% do not degrade electrolytics even after 2000 shots. These facts have several important consequences. Under fault mode conditions an electrolytic bank may be required to survive fault currents 10-100 times normal operation yet still operate reliably. Because of their high internal ESR, 50-100 m $\Omega$  typical, the surge currents are effectively limited if the output of the bank is shorted. However, if voltage reversal does occur under short circuit conditions, no significant damage to the capacitors results. In addition, if a capacitor is shorted, voltage reversal on the capacitors would be unlikely due to the high ESR per capacitor.

### SCR SELECTION

The selection of the high voltage, high current SCR's is not straightforward. A brief synopsis illustrates some of the trade-offs encountered in the selection process. Previous experience with both single shot systems and rep-rate systems show that most pulse power applications can safely operate SCR's and high current diodes at several times their specific 60 Hz surge current ratings. Both General Electric and Westinghouse (now Powerex) have subcycle surge current rating charts (based on empirical data) which scale the ratings down to the 0.1 msec range.<sup>6</sup> In principle, scaling assumes two facts. The first assumption is that the mechanical construction (leads, internal bonds) of the SCR will survive the higher currents and associated forces. In addition, the SCR gate layout of the device significantly impacts the turn-on time of the device. The power dissipated by a solid state device determines the final junction temperature, thus conduction over the full surface during the turn-on time is required for reliable operation. Primarily, the SCR's marketed for phase control applications are center-fired (e.g. WESTCODE P300 series). The gate is in the center of the device and the trigger signal propagates concentrically outward. Typical lateral propagation velocities of the trigger signal (charge carriers) are 10<sup>4</sup> cm/sec for phase control devices.<sup>7</sup> If a 30 millimeter diameter die is used in the SCR,

full conduction across the device will result in 15  $\mu$ s. Please note that no characterization of turn-on time versus varying gate voltage or current has been found in the literature. In fact most manufacturers suggest using approximately 3-5 times the required gate current to trigger the large phase control SCR's. In addition, the subcycle charts have been found to be accurate when extrapolated to the ten's of microseconds range. Previous rep-rate experience has confirmed the extrapolated current parameters showing that if proper heatsinking is used the designer can in fact exceed the device rating a factor of two over even the scaled subcycle surge-rating.

One example of the scaling of SCR's is the operation of the WESTCODE P300CH12F2K0 at higher currents than specified. The Westcode diode is rated at about 1120 A during normal 8.3 ms conduction. During surge currents the device is rated at 10.45 kA for 10 ms conduction times when no voltage reversal is present. Calculations show that the device will carry 20 kA for 2 ms, and 30 kA for 100  $\mu$ s. Actual experience has shown that typically even these surge current ratings can be exceeded if the  $A^2s$  product is not exceeded.

In either single shot or rep-rate applications the  $A^2s$  product conducted by the device should be computed. The  $A^2s$  is the fusing capability of the junction. Several applications have shown that the  $A^2s$  used by the manufacturer is conservative and can be exceeded by a factor of two to three in single shot applications. Most manufacturers assume an initial junction temperature of 125°C. The manufacturer then does a thermal calculation to find the final junction temperature. For single shot junction temperatures, the junction temperature may rise as high as 350°C. Inherently for rep-rate conditions, the junction temperature should not exceed 300°C. The di/dt ratings of the device depend heavily upon the voltage held off by the SCR. Similarly, if saturable inductors are used to prevent current conduction during the turn-on time of the device, the di/dt ratings can easily be exceeded.

### CONTROL SYSTEM

A computer-camac-controlled system was selected for precise control and monitoring of the capacitor banks (Figure 4). Nine capacitor banks (fifteen

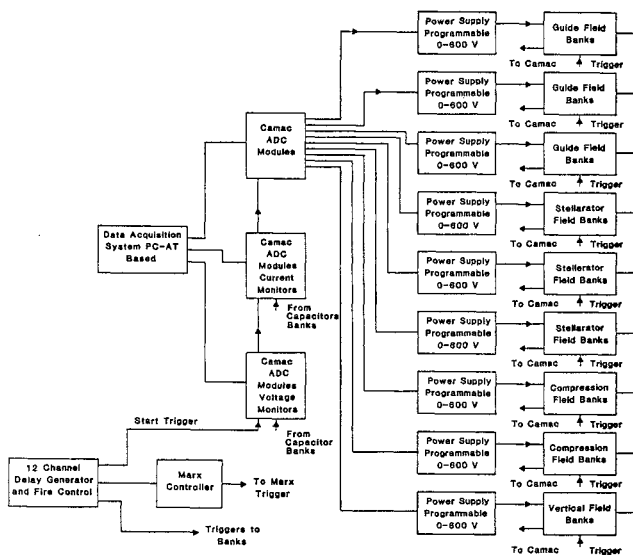

Figure 4. Camac crate based control and diagnostic system.

modules) were designed for operation with separate power supplies and diagnostics. The commercial camac modules and software allow remote control and monitoring of the individual banks. Adjustment of the charge voltage to better than 1% is expected. Voltage and current monitoring of the banks has been implemented, and actual simultaneous testing and checkout of the full system awaits arrival of the magnets. Implementation of remote voltage programmability via DAC camac modules is under development.

### TESTING

The fifteen capacitor bank modules constructed for the required nine capacitor banks have been tested individually and in a series connected pair. Due to the long lead time encountered in their magnet winding manufacture, the nine banks required testing into a dummy load. The 33 mF capacitor bank modules were discharged into a 35 mΩ ± 21 μH load. At 450 V charge voltage the bank's discharge current was 7.5 kA (Figure 5). The current risetime was 620 μs with dI/dt = 16 A/μs. All fifteen modules were exceptionally reliable when tested in the 2A3 ms damped discharge mode. A total of about 300 shots were fired during testing. One bank was tested for about 100 shots. No reliability problems were noted during the tests.

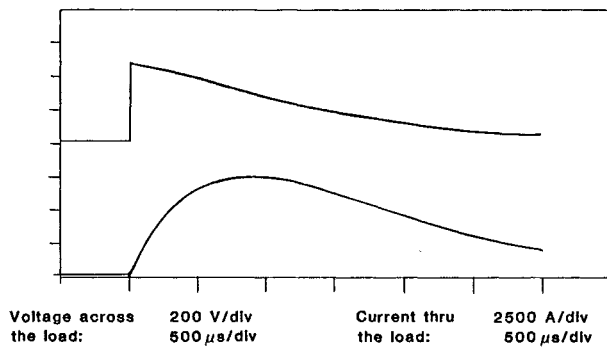

Figure 5. Discharge of single capacitor bank module into test load;  $V_{ch} = 450$  V.

A series connected pair was discharged in the same 35 mΩ to 21 μH, resistive/inductive load. The bank was tested at 15 kA (full charge voltage  $V = 450$  V); peak currents to assess the reliability of the bank (Figure 6). Note that even though the SCR conducted currents of 15 kA which specifically exceeds their 8.3 ms surge current rating of 10.5 kA no problems were noted. In addition each SCR transferred 14.8 Coulombs and 6.8 kJ per shot.

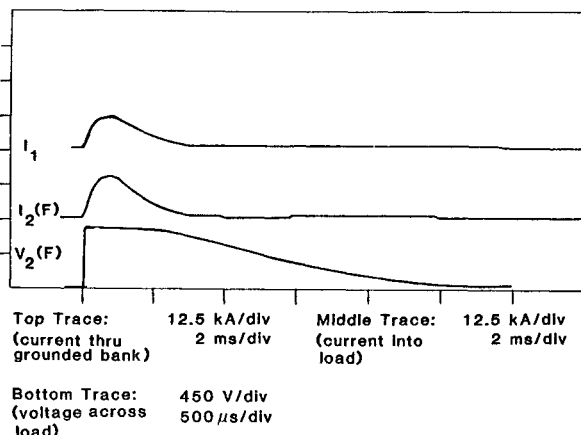

Figure 6. Discharge of two series connected capacitor banks into test load;  $V_{ch} = 900$  V.

### CONCLUSION

The capacitor bank modules operated reliably as designed. Both electrolytic capacitors and SCR switched banks offer an attractive design option to the capacitor bank designer. To summarize the operating characteristics of the SCR switched bank capabilities available, the significant operational parameters of the banks are listed in Table 1. Both the Coulomb capability and energy capability of present silicon controlled rectifiers are impressive when compared against ignitrons. This affords a unique design capability to pulse power engineers designing lightweight high current systems.

Table 1. Summary of risetimes, charge and energy transfer, through SCR.

	SCR Specification (60 Hz Operation)	Single Module Test	Two Seriesed Modules
Risetime (10-90)	NA	620 μs	312 μs
Voltage	1200 V	450 V	900 V
$I_p$ (pulse current)	1.18 kA	NA	NA
$I_{scm}$ (surge current) (5% actual operating current)	10.5 kA	7 kA	15 kA
Energy per pulse	NA	3.4 kJ	6.8 kJ
Coulomb Transfer	NA	14.85 C	14.85 C
dI/dt	1000 A/μs	16.5 A/μs	24 A/μs
$\Lambda^2$ s	$5.46 \times 10^5$	$84.3 \times 10^4$	$3.34 \times 10^5$

NA = not applicable

### ACKNOWLEDGEMENTS

The authors would like to take this opportunity to thank Hugh Kirby at LLNL for the helpful suggestions on conditioning electrolytics. The design suggestions offered by Dr. Leland Schlitt, Mr. Jim Fockler, and Mr. Phil Champney are also gratefully acknowledged.

### REFERENCES

1. A.A. Mondelli, et al., "A Strongly Focussed SPIRAL-LINE Recirculating Induction Linac," to be published in conference proceedings of "Beams '86".
2. V. Bailey, L. Schlitt, et al., "An Experimental Program to Investigate the STRONGLY FOCUSED SPIRAL LINE Recirculating Induction Accelerator," proceedings of the 1987 Particle Accelerator Conference, 16-19 March 1987, Washington, D.C.
3. Don Hopkins and Pierre F. Pellissier, "A High-Voltage electrolytic Capacitor," LBL publication UCRL#9968, 1961.
4. Louis Reginato and Bob Smith, "Construction and Testing of the 2XIIIB Flat Topping Power Supply," Sixth Symposium on Engineering Problems of Fusion Research, 18-21 November 1975, San Diego, Ca.
5. Don Hopkins, "Electrolytic Capacitor Banks," LBL publication UCRL#16263, 1965.
6. Private communication, Bill Carsted and Joe Rickett Westinghouse (now Powerex), June 1987.
7. L.R. Rice, "Westinghouse Silicon-Controlled Rectifier Designers Handbook," 2nd Edition, September 1970, Youngwood, PA.