

ALIGNMENT OF THE HERMES-III MAGNETICALLY INSULATED TRANSMISSION LINE*

E. L. Burgess, G. W. Crowder, M. C. Dowdican, J. C. Patterson, T. L. Franklin, S. J. Robischon, K. M. Tolk, J. J. Ramirez, D. L. Johnson, and R. C. Pate

Sandia National Laboratories
Albuquerque, New Mexico 87112

Abstract

Hermes-III is a 20-MV machine which contains an 18.7-m-long magnetically insulated transmission line (MITL). The cylindrical MITL cathode is cantilevered from one end and must be accurately aligned within the anode. This paper describes the mechanical design for accomplishing this alignment.

Introduction

Hermes-III is a gamma ray simulator being built at Sandia National Laboratories as part of the Simulation Technology Laboratory (STL). The pulsed power accelerator is designed to create a 20-MV pulse at the diode/converter. This is accomplished by feeding 20 inductive cavities, connected electrically in series, with 1-MV pulses from pulse forming lines (PFL). The cavity outputs are added along a 12.8-m section of an 18.7-m-long MITL.

The MITL anode is formed by the inside bore of the inductive cavities, the spacer spools which separate five groups of four cavities, and a 5.9-m anode extension (Fig. 1). The MITL cathode is a cylindrical structure inside the anode. The anode/cathode (A-K) gap increases from the low voltage to high voltage end of the MITL in order to provide proper impedance matching and maintain the magnetic insulation as voltage increases. This variable A-K gap is accomplished by reducing the diameter of the cathode in steps between cavities. Each cavity has a 3.2-m outside diameter, a 0.76-m inside diameter, and a weight of approximately 5000 kg without insulating oil. The cathode is 0.73 m in diameter at the large end and steps down, in 20 steps, to a diameter of 0.37 m at the small end; it weighs approximately 2200 kg. The 18.7-m-long cathode is cantilevered from a support structure at the low-voltage end of the machine. For more details on the design, refer to Ramirez, et al. [1].

The machine geometry and size presented a challenge for the mechanical design and alignment of the MITL. From an electrical performance point of view, it is desirable to align the MITL, i.e., to position the cathode in the center of the anode bore, as accurately as possible. It is difficult to predict, from a performance model, just how accurate this alignment must be. At present there are no experimental data on an MITL adder this large which relate electrical performance to alignment accuracy. Therefore, alignment became a compromise between the

desire to align the MITL to a very close tolerance and practical limits established by manufacturing tolerances, mechanical placement and support schemes, and machine assembly and maintenance.

This paper describes the development of an alignment criteria and the mechanical design and procedures for accomplishing the alignment of the Hermes-III MITL to meet the criteria.

Alignment Criteria Development

Experimental Data

Usually the development of criteria for an accelerator component is based on past performance experience. In the case of the Hermes-III MITL no such experience existed for the effect of gap alignment on performance. To help define the alignment criteria, a series of experiments was performed on Helia, a 4-cavity, 4-MV, 250-kA prototype of Hermes-III. One experiment involved introducing an abrupt misalignment in the MITL anode extension surface. A misalignment of 5% of the A-K gap produced no measurable losses. When the gap was misaligned by 25%, noticeable losses occurred. A second experiment involved tilting the MITL cathode with respect to the anode to introduce misalignment. Again, tilts introducing 5% misalignment did not cause any measurable loss in current flow. When tilts producing misalignments of 25% were introduced, significant asymmetries in the current flow resulted with some slight current loss.

These tests, although not conclusive because of the gross difference in size and operating voltage between the Helia and Hermes-III MITLs, helped to establish an alignment criteria.

Overall Alignment Criteria

The limited experimental data indicated that an alignment accuracy of 5% of the A-K gap would be adequate to prevent current flow problems due to misalignment. Since the A-K gap increases to 15.9 cm at the high voltage end of the MITL, a 5% misalignment would yield 0.8 cm absolute misalignment. This large nonconcentricity seemed undesirable, particularly since the Helia experimental data only went to 4 MV and Hermes-III will operate at 20 MV.

A detailed analysis was performed for each step of the

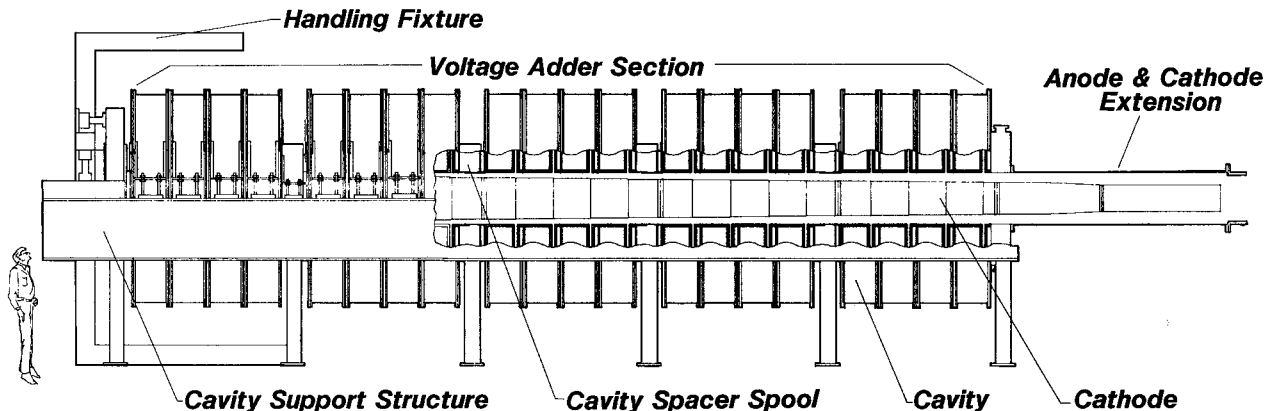

Figure 1 - Hermes-III MITL with cut-away showing cathode.

*This work was supported by the U.S. Department of Energy under Contract No. DE-AC04-76DP00789.

Report Documentation Page

Form Approved
OMB No. 0704-0188

Public reporting burden for the collection of information is estimated to average 1 hour per response, including the time for reviewing instructions, searching existing data sources, gathering and maintaining the data needed, and completing and reviewing the collection of information. Send comments regarding this burden estimate or any other aspect of this collection of information, including suggestions for reducing this burden, to Washington Headquarters Services, Directorate for Information Operations and Reports, 1215 Jefferson Davis Highway, Suite 1204, Arlington VA 22202-4302. Respondents should be aware that notwithstanding any other provision of law, no person shall be subject to a penalty for failing to comply with a collection of information if it does not display a currently valid OMB control number.

1. REPORT DATE JUN 1987		2. REPORT TYPE N/A		3. DATES COVERED -		
4. TITLE AND SUBTITLE Alignment Of The Hermes-Iii Magnetically Insulated Transmission Line				5a. CONTRACT NUMBER		
				5b. GRANT NUMBER		
				5c. PROGRAM ELEMENT NUMBER		
6. AUTHOR(S)				5d. PROJECT NUMBER		
				5e. TASK NUMBER		
				5f. WORK UNIT NUMBER		
7. PERFORMING ORGANIZATION NAME(S) AND ADDRESS(ES) Sandia National Laboratories Albuquerque, New Mexico 87112				8. PERFORMING ORGANIZATION REPORT NUMBER		
9. SPONSORING/MONITORING AGENCY NAME(S) AND ADDRESS(ES)				10. SPONSOR/MONITOR'S ACRONYM(S)		
				11. SPONSOR/MONITOR'S REPORT NUMBER(S)		
12. DISTRIBUTION/AVAILABILITY STATEMENT Approved for public release, distribution unlimited						
13. SUPPLEMENTARY NOTES See also ADM002371. 2013 IEEE Pulsed Power Conference, Digest of Technical Papers 1976-2013, and Abstracts of the 2013 IEEE International Conference on Plasma Science. Held in San Francisco, CA on 16-21 June 2013. U.S. Government or Federal Purpose Rights License						
14. ABSTRACT Hermes-III is a 20-MV machine which contains an 18.7- m-long magnetically insulated transmission line (MITL). The cylindrical MITL cathode is cantilevered from one end and must be accurately aligned within the anode. This paper describes the mechanical design for accomplishing this alignment.						
15. SUBJECT TERMS						
16. SECURITY CLASSIFICATION OF:				17. LIMITATION OF ABSTRACT SAR	18. NUMBER OF PAGES 4	19a. NAME OF RESPONSIBLE PERSON
a. REPORT unclassified	b. ABSTRACT unclassified	c. THIS PAGE unclassified				

MITL alignment procedure to determine a reasonable accuracy from a mechanical positioning point of view. This analysis indicated that an alignment at the high voltage end to within 0.32 cm was possible; at the smaller gaps in the lower voltage regions, 5% accuracy was possible but ambitious. Therefore, an overall alignment criteria was established as the lesser of $\pm 5\%$ of the nominal gap or ± 0.32 cm over the full MITL length.

Allocation of Alignment Errors

The overall alignment scheme involves positioning of the inductive cavities, straightening the MITL cathode, and positioning the cathode within the MITL anode formed by the cavity bores. In order to establish a positioning criterion for adjustment mechanisms for these steps, the overall alignment error was apportioned among the subsystems. Table I lists the allocation of alignment errors. The allocation was done somewhat arbitrarily; however, a worst-case analysis was done using the allocations and that analysis showed that the allocation of errors was reasonable. Table II is the result of this analysis; note that, in this worst-case scenario, the 5% criterion at the second through fourth cavities is exceeded.

Table I - Alignment criteria allocated to MITL components and handling fixture.

Cavities and Cavity Spacer Spools

Cavities:
 Perpendicular to Machine Centerline ± 0.5 mrad
 Centered on Machine Centerline Lesser of $\pm 2\%$ of Gap or ± 0.13 cm
 Longitudinal Position Within ± 0.16 cm of Tank PFL Port

Cavity Spacer Spools:
 Centered on Machine Centerline Lesser of $\pm 2\%$ of Gap or ± 0.13 cm

Cathode

Straightness Lesser of $\pm 2\%$ of Gap or ± 0.13 cm

Cathode Handling Fixture

X-Y Plane Positioning ± 0.038 cm at First Cavity
 Angular Positioning ± 0.04 mrad

Table II - Worst-case alignment scenario.

Cavity No.	Gap (cm)	H-Fix Position (cm)	A=K Position (cm)	Cav Tilt (cm)	Total Error (cm)	Criteria (cm)	Error (%)
1	1.575	0.038	0.000	0.014	0.052	0.079	3.31
2	1.575	0.039	0.031	0.014	0.116	0.079	7.37
3	2.701	0.040	0.054	0.014	0.162	0.135	6.00
4	3.739	0.041	0.075	0.014	0.204	0.187	5.47
5	4.781	0.043	0.094	0.014	0.245	0.236	5.20
6	5.653	0.043	0.113	0.014	0.284	0.283	5.02
7	6.549	0.044	0.127	0.014	0.312	0.318	4.77
8	7.414	0.045	0.127	0.014	0.313	0.318	4.23
9	8.249	0.047	0.127	0.014	0.315	0.318	3.82
10	9.055	0.048	0.127	0.014	0.316	0.318	3.49
11	9.835	0.049	0.127	0.014	0.317	0.318	3.22
12	10.593	0.050	0.127	0.014	0.318	0.318	3.00
13	11.326	0.051	0.127	0.014	0.319	0.318	2.82
14	12.037	0.052	0.127	0.014	0.320	0.318	2.66
15	12.727	0.053	0.127	0.014	0.321	0.318	2.52
16	13.397	0.054	0.127	0.014	0.322	0.318	2.40
17	14.049	0.056	0.127	0.014	0.324	0.318	2.30
18	14.681	0.057	0.127	0.014	0.325	0.318	2.21
19	15.296	0.058	0.127	0.014	0.326	0.318	2.13
20	15.893	0.059	0.127	0.014	0.327	0.318	2.06
Ext	16.474	0.064	0.000	0.014	0.077	0.318	0.47

Alignment Description

Several steps are involved in the alignment of the Hermes-III MITL: a) installing the inductive cavities and cavity spools and aligning their bores along the machine centerline, b)

assembling and straightening the MITL cathode with extension installed outside the machine, c) removing the MITL cathode extension, installing the MITL cathode into the machine and replacing the MITL cathode extension, d) aligning the cathode within the cavity bores, e) calibrating the linear voltage differential transformers (LVDT) in the cavity spools, f) installing and aligning the anode extension and diode, and g) evacuating the machine to operating pressure, verifying, with the LVDTs, the alignment, and making any necessary adjustments using the MITL handling fixture. These steps are described in detail below.

Cavity Installation and Alignment

The cavities are installed into the machine in groups of four with a cavity spacer spool installed between each group; there are a total of five groups of cavities. The longitudinal position of each cavity is not critical (± 0.16 cm) and is accomplished using standard measurement techniques. Alignment of the cavity bores on the machine centerline is more critical and is accomplished with precision positioners and accurate measurement devices.

The heart of the alignment system is a 0.7 milliwatt helium-neon autocollimating laser. The laser is placed on a kinematic mount fastened to the cavity support rails (Fig. 2). The laser is then aimed along the machine and positioned, using the PFL ports on the oil tank sides as references, to establish the centerline of the machine and MITL. The cavities are then aligned to this centerline. The kinematic mount allows the laser to be removed and reinstalled without losing this centerline; however, as a precaution, reference marks are placed on the building walls so that an additional means of reestablishing the centerline is available.

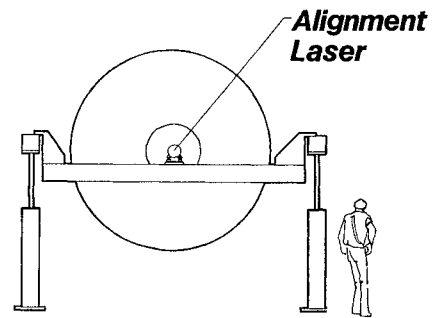

Figure 2 - Alignment laser mounted on cavity support rails.

Each cavity must be aligned perpendicular to this centerline to within ± 0.5 mrad; greater nonperpendicularity causes unacceptable MITL gap misalignment because of the finite cavity thickness (Fig. 3). In addition, the cavity bores must be centered on the centerline to meet the criteria. The cavity support structure incorporates positioners which allow precision motion to accomplish the alignment. A fixture was designed to facilitate the alignment procedure (Fig. 4). The fixture contains an x-y position photodiode and a target centering device to position the photodiode in the geometric center of the cavity spool. In addition, an optically flat mirror can be attached magnetically to

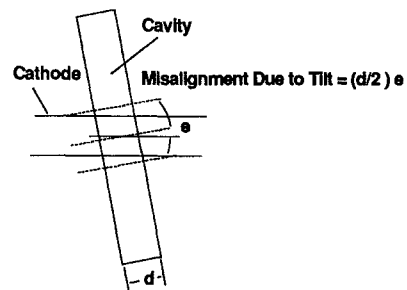

Figure 3 - Alignment error caused by cavity tilt.

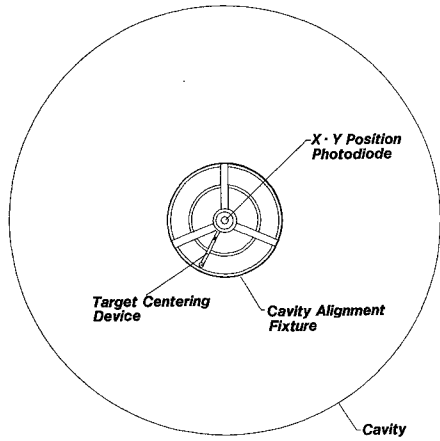

Figure 4 - Cavity alignment fixture.

the fixture with its face parallel with the cavity face. The cavity bore is centered using the support structure positioners and the alignment laser in conjunction with the x-y position photodiode; the resolution of the photodiode is ± 0.0025 cm. The cavity face is made perpendicular to the machine centerline using the auto-collimating feature of the alignment laser with the mirror attached to the alignment fixture. The autocollimator is capable of resolution to ± 0.014 mrad.

The cavities are installed into the machine starting with the high voltage end of the machine. The first cavity of the group is aligned perpendicular and centered about the centerline as described above. This cavity is then rigidly attached to the main cavity support structure. The second through fourth cavities of each group need only be centered since their faces will mount flush with each other and the perpendicular alignment is established by the first cavity. After all four cavities of a group are installed and aligned, a cavity spacer spool is installed and its bore is centered using the same procedure as for a cavity. The sequence is then repeated until all 20 cavities are installed. The result is a straight (to within allowable tolerance) MITL anode formed by the cavity and cavity spacer spool bores.

MITL Cathode Assembly and Straightening

The MITL cathode is made up of seven large aluminum cylindrical sections with bolted diagnostic rings between adjoining sections. If no straightening techniques were used,

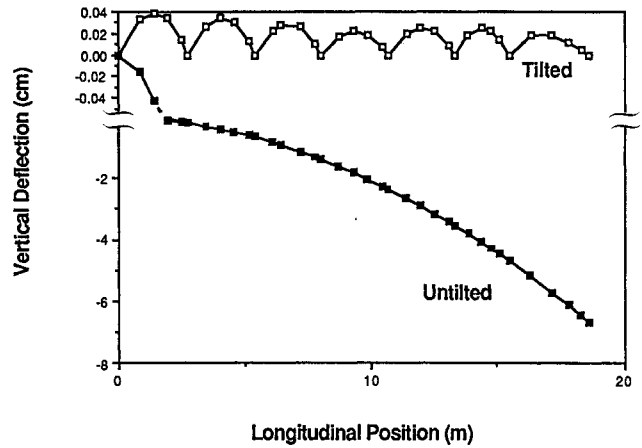

Figure 5 - Calculated MITL cathode deflections with and without straightening using tilt spacers.

this cantilevered, 18.7-m structure would deflect approximately 7 cm at the free end (Fig. 5) and would not meet the alignment criteria. A deflection model of the cathode was formulated and the curvature of the structure was found to be very small. Therefore, each individual section would be straight enough to meet the alignment criteria and the overall structure could be made to meet the criteria if each section were tilted to point along the centerline of the machine. This concept is illustrated in Fig. 6.

These strategic tilts are accomplished with "wedge-shaped" tilt spacers as illustrated in Fig. 6. The tilt spacers consist of two rings; each ring has one sloped face. By rotating these rings with respect to each other, a variety of tilt directions can be introduced (Fig. 6). A computer program was developed to describe the straightness of the MITL cathode using discrete-step spacers, i.e., adjustment by rotating one ring's bolt hole pattern with respect to the other ring's bolt hole pattern. This program uses a deflection model to calculate the theoretical vertical tilt angles necessary to straighten gravity induced deflections. Worst-case horizontal tilts due to flange machining errors were superimposed on the vertical gravity tilt angles to give a set of tilt angles necessary to straighten the cathode to within the alignment criteria. This set of angles was then compared to the available angles defined by discrete-step tilt spacers. This comparison defined the number of steps, or bolt holes, necessary to

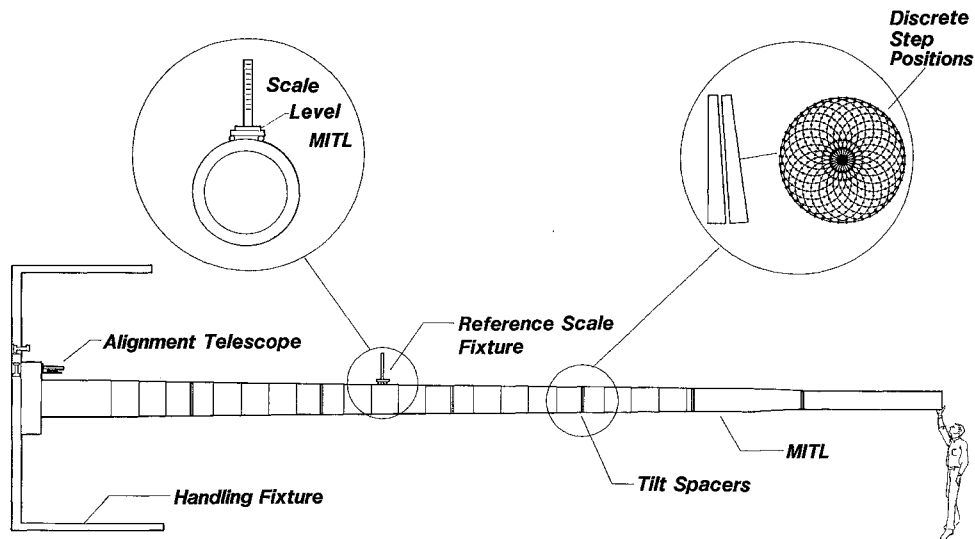

Figure 6 - Assembled MITL cathode showing tilt spacers and straightness measurement scale.

meet the straightness criteria. The final design called for 24 bolt holes in the adder region and only 12 in the extension region. Plots of the theoretical straightness profiles for this design are shown in Fig. 7.

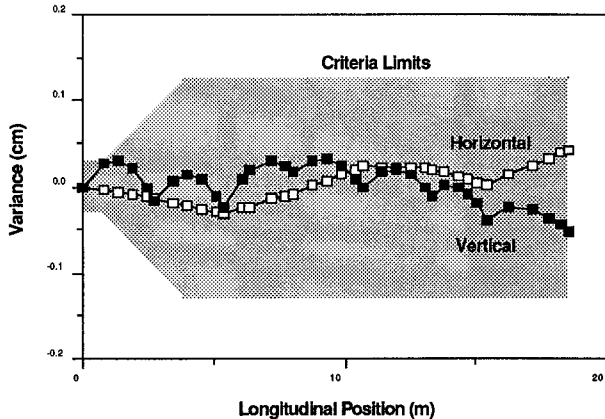

Figure 7 - Calculated MITL cathode straightness profiles using discrete step tilt spacers.

The MITL cathode is preassembled on the MITL handling fixture outside the Hermes-III machine. Initial settings for the tilt spacers are calculated using the computer program and actual dimensional inspection data of the manufactured sections. After the cathode is fully assembled on the handling fixture, including the extension, straightness is checked using an alignment telescope. This telescope is mounted and pointed perpendicular to the handling fixture toward the end of the cathode to produce a horizontal reference. A small fixture with a vertical scale (Fig. 6) is placed on top of the MITL cathode and leveled. A reading is made through the alignment telescope from this scale for each step in each section of the cathode. The straightness can then be determined from these measurements. The resolution of the telescope is ± 0.0025 cm. If the initial set of tilt spacer settings fails to straighten the assembly adequately, a new set will be calculated using the measured straightness data. The cathode will then be disassembled and reassembled using the new tilt spacer settings. This process will be repeated until the straightness criteria are met. No more than one or two iterations are anticipated.

MITL Cathode Installation and Alignment

The next step in the MITL alignment is the installation and alignment of the cathode in the machine. Once the cathode has been straightened, the extension section is removed. The voltage adder section is then installed into the anode using the handling fixture. During installation of the adder section, removable guide wheels are attached to the front of the cathode to prevent bumping the anode bore. The cathode extension is reinstalled after the adder is inserted into the machine.

Alignment of the cathode with the anode is accomplished by adjustment mechanisms incorporated into the design of the handling fixture. The fixture is shown in Fig. 1. The fixture remains a part of the machine and holds the cathode during operation. When the fixture and cathode are at their operating position, the fixture is supported at three points by the cavity

support structure. Between the fixture and the cavity support structure are the adjustment mechanisms; these mechanisms provide x-y and angular positioning of the cathode both before and after a vacuum is created in the machine. In order to meet the alignment criteria allocated to the handling fixture, the angular adjustment mechanism had to have a positioning capability of ± 0.04 mrad. This dictated linear movements in increments of 0.09 cm or less. The actual design provides for a linear movement of 0.0064 cm per quarter turn.

Another consideration in the choice of the adjustment mechanism was the requirement to adjust the cathode under full load, i.e. complete weight of cathode carried by fixture. This places loads of up to 62,000 newtons on the mechanism and eliminated many of the possible adjustment mechanisms because of the excessive input torque required to actuate. A 10-ton machine screw actuator was chosen which requires an input torque, when fully loaded, of 42 newton-meters.

Since the MITL cathode is "straight," alignment requires only that the cathode be placed concentric with respect to the anode, within the alignment criteria, at each end of the anode. This is accomplished with the handling fixture screw actuators and measured with previously calibrated LVDTs inside the cathode at the fixture end and with a gage at the high voltage end. After this alignment is accomplished, LVDTs located in the cavity spacer spools are calibrated for later checking alignment when the machine is under vacuum and after it is fired.

Anode Extension Installation and Alignment

Finally, the anode extension is installed over the cathode extension. It is supported on two carts which roll on a rail system for ease of assembly and disassembly. The carts are adjustable in height, allowing the anode extension to be moved slightly to attain better alignment. A metal bellows is contained in the rear of the anode extension to allow movement of the anode without stressing its connection to the last cavity. Alignment is measured with LVDTs and gages at the open end.

Final Alignment Check and Adjustment

The diode [2] is installed and the machine is evacuated. The design of the MITL places almost equal loads on each end of the MITL when under vacuum; however, there is a possibility for alignment to change under the evacuated condition. Alignment can be checked with the previously calibrated LVDTs located in the cavity spacer spools and at the diode. If some misalignment occurs, it can be corrected with the screw actuators on the handling fixture.

Conclusions

The alignment system for the Hermes-III MITL is presently being fabricated. Alignment criteria was a compromise between the desire to align the MITL very accurately and the practical limits on positioning large, heavy components. Mechanical features were incorporated into the system to allow alignment to meet or exceed the final alignment criteria.

References

1. J. J. Ramirez, et al., "Hermes-III Program," 1987 Pulsed Power Conference.
2. T. W. L. Sanford, et al., "Indented-Anode Diode for Hermes-III," *ibid*.