

SPACE CHARGED SF₆ SWITCHING STUDIES

David B. Fenneman and R. Kenneth Hutcherson
Naval Surface Weapons Center
Dahlgren, VA 22448

Abstract

Because intense heating limits spark gap repetition rates, interest in diffuse discharge switching has been increasing. Experimental apparatus to determine possible diffuse discharge applications of space charged SF₆ gas is described as are the resulting high field electrical transport properties. In particular, prebreakdown current/voltage characteristics are reported for reduced fields $E/N \sim 10^{-15}$ V/cm² and prebreakdown ion currents ~ 100 microamperes. The effect of externally induced photo detachment is also investigated with emphasis on system switching parameters.

I. Background

High repetition rate pulse power systems require output switches which can recover their insulating (voltage hold-off) properties during the interpulse period. This return to the insulating state from the conducting state must be accomplished by the natural carrier loss mechanisms of the switch medium. The switch closing process on the other hand can be strongly influenced by external means: the triggering scheme. Thus there is a fundamental difference between the influence the switch designer can exert on the switch closing process (carrier production) and the influence he can exert on the opening process (carrier destruction). High repetition rate (i.e., fast recovery) switch design therefore must pay special attention to the possible carrier destruction processes of candidate switch media. Choice of switch medium is virtually the only option of the switch designer with which to influence the opening process.

Restricting the discussion to high pressure gaseous switches, the electron attachment process in electronegative gases is quickly recognized as a primary candidate process for fast recovery switching.

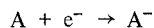

The best known electronegative gas is SF₆ and for good reason. Its electron attachment cross section is indicated in Figure 1.

These data indicate the lifetime of a room temperature (~ 25 meV) electron in field free SF₆ at STP is a small fraction of a picosecond! Such small carrier lifetimes give hope that fast recovery gas switching is possible. However, it must be stated that such optimistic conclusions are somewhat premature (like the report of Twain's death). Closer examination of the process shows that attachment must be collisionally stabilized.^{2,3} Which is to say that because the equilibrium radius of newly created SF₆⁻ is considerably larger than the SF₆ molecule, the ion is created in a highly excited vibrational state, from which it must relax via single quantum processes to the ground state in order to permanently bind the electron.⁴ This requirement for vibrational deexcitation together with the fall off of attachment cross section to nil for temperatures typical of spark gaps ($\sim 10,000$ K, or ~ 1 eV) indicates the thermal violence of spark gaps easily nullifies the attachment process. Indeed, recent recovery

studies of SF₆ containing spark gaps to be reported at this conference do not show the dramatic decrease in recovery time compared to other gases as might be hoped on the basis of a naive interpretation of the attachment cross section.

It appears clear that if the large attachment cross section of SF₆ is to form the basis of a rapidly recovering switch, the gas molecules must not be hot during the recovery period. For a given voltage drop across a switch during conduction, the rate of temperature rise is inversely proportional to the cross sectional area, indicating that a large cross sectional switch, or "diffuse" discharge is needed to restrict the temperature rise. Bulk ionization processes have been used to create diffuse discharges in SF₆, mainly electron beam excitation⁵ and UV photo excitation combined with simultaneous over-volting.⁶

Whatever mechanism is employed to create the diffuse discharge, it is felt three conditions are of prime importance. Firstly, the discharge must be initiated by bulk carrier production processes which are reasonably uniform throughout the conduction volume, and secondly, the electrons must not be allowed to come to thermal equilibrium with the neutrals during the conduction period. In addition, pulse power switching requirements of low impedance loads lead to the restriction that the effective on impedance of bulk discharge devices be no larger than about 50 ohms/cm². This infers high pressure bulk discharges must achieve carrier densities on the order of 10^{15} /cm³.

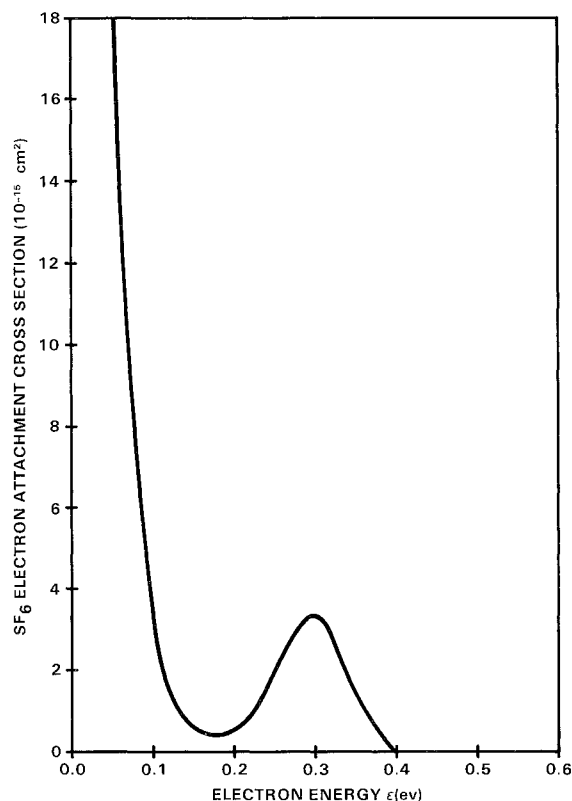

Fig. 1. Electron attachment cross section in SF₆ as function of electron energy, after Christophou¹

Report Documentation Page

Form Approved
OMB No. 0704-0188

Public reporting burden for the collection of information is estimated to average 1 hour per response, including the time for reviewing instructions, searching existing data sources, gathering and maintaining the data needed, and completing and reviewing the collection of information. Send comments regarding this burden estimate or any other aspect of this collection of information, including suggestions for reducing this burden, to Washington Headquarters Services, Directorate for Information Operations and Reports, 1215 Jefferson Davis Highway, Suite 1204, Arlington VA 22202-4302. Respondents should be aware that notwithstanding any other provision of law, no person shall be subject to a penalty for failing to comply with a collection of information if it does not display a currently valid OMB control number.

| | | | |
|--|------------------------------------|--|---------------------------------|
| 1. REPORT DATE JUN 1985 | 2. REPORT TYPE N/A | 3. DATES COVERED - | |
| 4. TITLE AND SUBTITLE Space Charged Sf6 Switching Studies | | 5a. CONTRACT NUMBER | |
| | | 5b. GRANT NUMBER | |
| | | 5c. PROGRAM ELEMENT NUMBER | |
| 6. AUTHOR(S) | | 5d. PROJECT NUMBER | |
| | | 5e. TASK NUMBER | |
| | | 5f. WORK UNIT NUMBER | |
| 7. PERFORMING ORGANIZATION NAME(S) AND ADDRESS(ES) Naval Surface Weapons Center Dahlgren, VA 22448 | | 8. PERFORMING ORGANIZATION REPORT NUMBER | |
| 9. SPONSORING/MONITORING AGENCY NAME(S) AND ADDRESS(ES) | | 10. SPONSOR/MONITOR'S ACRONYM(S) | |
| | | 11. SPONSOR/MONITOR'S REPORT NUMBER(S) | |
| 12. DISTRIBUTION/AVAILABILITY STATEMENT Approved for public release, distribution unlimited | | | |
| 13. SUPPLEMENTARY NOTES See also ADM002371. 2013 IEEE Pulsed Power Conference, Digest of Technical Papers 1976-2013, and Abstracts of the 2013 IEEE International Conference on Plasma Science. Held in San Francisco, CA on 16-21 June 2013. U.S. Government or Federal Purpose Rights License. | | | |
| 14. ABSTRACT Because intense heating limits spark gap repetition rates, interest in diffuse discharge switching has been increasing. Experimental apparatus to determine possible diffuse discharge applications of space charged SF 6 gas is described as are the resulting high field electrical transport properties. In particular, prebreakdown current/voltage characteristics are reported for reduced fields $E/N \sim 10-15$ vI cm² and pre breakdown ion currents 100 microamperes. The effect of externally induced photo detachment is also investigated with emphasis on system switching parameters. | | | |
| 15. SUBJECT TERMS | | | |
| 16. SECURITY CLASSIFICATION OF: | | | 17. LIMITATION OF ABSTRACT |
| a. REPORT unclassified | b. ABSTRACT unclassified | c. THIS PAGE unclassified | SAR |
| | | | 18. NUMBER OF PAGES 4 |
| | | | 19a. NAME OF RESPONSIBLE PERSON |

II. The Space Charged Switch

A. Conceptual Development

The preceding considerations have led to the development of the concept of the space charge limited photoactivated switch. The idea centers on pre-loading the switch volume with as much space charge, in the form of SF_6^- ions as possible. Triggering would then be accomplished by photo-detaching the electrons from the parent molecules. If the electrons can be detached in sufficient quantity with sufficient energy to escape the reattachment cross section, a uniform discharge cascade could result even though the local field is below the townsend critical value. Besides initiating the photo-detachment electron cascade, the photons will engage in a plethora of other reactions: photo ionization, photo-electric effect, photo-excitation, all of which serve to defeat the reattachment mechanism. But most importantly, the photons represent an entity in the switch volume to which the electrons are strongly coupled and with which the electrons will try to come to equilibrium at the high temperature characterized by the mean photon energy. When switching current ceases and the photon source is removed, the electrons will cool to the bulk gas temperature and rapidly reattach, reestablishing the insulating phase. Figure 2 displays a possible embodiment of such a switch. An electron corona discharge is produced from a negatively charged anisotropic electrode array. The corona emitted electrons become attached as they drift towards the grounded cathode. In SF_6 at one atmosphere the mean path for attachment is about 10^{-5} cm so a drift distance of 1mm represents 10,000 paths. The current becomes ionic rather than electronic. Ions which do not strike the cathode grid will pass through and fall under the influence of the high voltage anode field and drift towards it. As steady state is reached, the ion drift region will become loaded with negative space charge. The switch is triggered by the flashlamp whose light photodetaches the electrons and assists in the maintenance of the diffuse discharge.

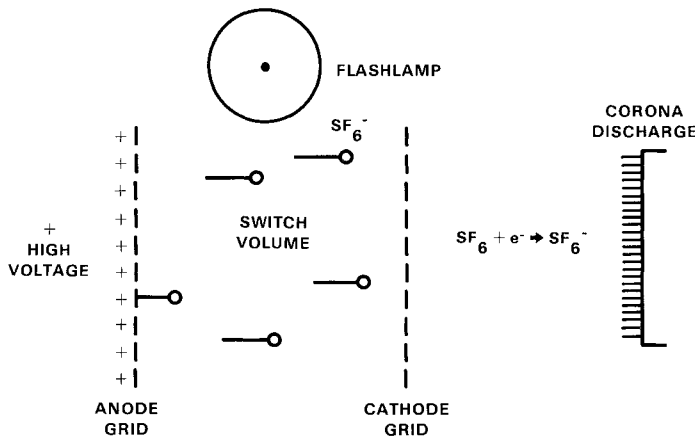

Fig. 2. The space charged switch concept

B. Analysis

Such a switch differs in many ways from most present switches. Primarily, the electric field inside the switch is not constant during the insulating phase (i.e., the applied voltage divided by the gap spacing) but varies continuously from cathode to anode. The field distribution is governed by

Poisson's equation:

$$\frac{d}{dz} (E(z)) = n_i(z) e / \epsilon \quad (1)$$

The ion current density is

$$J(z) = n_i(z) \mu e E(z) = \text{constant} \quad (2)$$

substituting (2) into (1), integrating twice, assuming space charge limited current (i.e., the field at the cathode is zero) yields the current-voltage characteristic of the predischage phase.

$$j = \frac{9}{8} \mu e \frac{V^2}{d^3} \quad (3)$$

the field inside a fully space-charged gap is given by

$$E(z) = \frac{3}{2} \frac{V}{d} \sqrt{\frac{z}{d}} \quad (4)$$

and the ion density is

$$n_i(z) = \frac{3}{4} \frac{\epsilon}{e d} \frac{V}{\sqrt{z d}} \quad (5)$$

These equations demonstrate that in space charge loaded gaps the field varies from zero at the cathode to one and one half times the field ($=V/d$) of a space charge free gap. The ion density varies from infinity at the cathode to $3/4 (V/d)$ at the anode. To appreciate the magnitude of space charge which might be created, consider a 1cm gap charged to 50 kV. The ion density is minimum at the anode $n_i(d) = 2 \times 10^{10}/\text{cm}^3$ and increases as one approaches the cathode. Thus considerable charge density could be injected into typical gaps. The electron affinity of SF_6^- is about 0.5 eV compared to the ionization energy of SF_6 , 15.8 eV. If the photo detachment process can be made effective, a large quantity of seed electrons could be produced in the gap volume at small energy cost. Relatively small electron cascade gains of from $10^4 - 10^5$ are all that is required to increase the system conductivity to levels required for pulsed power switching.

C. Test Device

In order to test these ideas, a prototype switch was constructed. The test switch configuration is displayed in Figure 3. The switch housing is a grounded brass cylinder of length 12 cm and 12 cm inner diameter with removable end plates. Observation ports with quartz windows allow restricted viewing of the switching region. Slowly flowing SF_6 gas is inlet to the housing at the base of the corona needles and exits via the anode grid. High voltage is fed through one end plate to the anode. The cathode grid is grounded to the housing. Both grids are of common brass screen with grid size 1.5 mm x 1.5 mm. The ratio of grid open area to closed area is about 0.7. The corona discharge is produced by a 4.1 x 0.8 cm. Rectangular array of 68 stainless steel sewing needles which may be excited to 10 kV negative potential with respect to ground. Both anode grid-cathode grid and corona needle-cathode grid spacing are adjustable.

Typical values of anode-cathode spacing lie between 0.5-1.0 cm, and the needle-cathode spacing varies from 0.1 to 0.3 cm.

Triggering is accomplished by a xenon flash tube housed in a rectangular blister on the switch housing cylinder. The $0.5 \mu\text{f}$ flash tube capacitor may be charged to 1500v maximum. Flash duration from 1/6 maximum intensity points is approximately 600 ns. Based on manufacturer's data, the radiance in the switching volume should exceed 100 W/cm^2 . The spectrum peak for the standard bulb envelope tube is 425 nm. Radiation shorter than 300 nm is absorbed by the envelope.

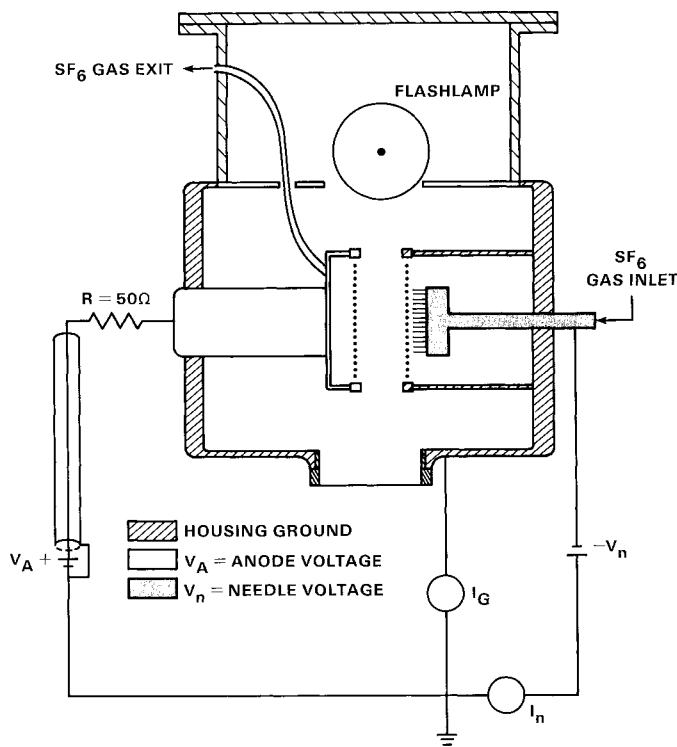

Fig. 3. Test device schematic

III. Experimental Set-up and Results

A. Set-up

Figure 4, shows the experimental set-up used to test the space charged switch. A 50 kV dc power supply is used to charge 100 feet of 50 ohm cable through 50 ohm charging resistors. The cable terminates at the other end with a matching 50 ohm carborundum resistor which joins the switch assembly. The predischage ion current is measured with ammeters in the needle current loop and the grid current loop. After triggering, cable discharge voltages are measured with coaxial capacitive probes located on both sides of the 50 ohm resistor. The probes have been found to have response times better than 10 ns and have rc droop times of a few microseconds. Thus the capacitive probes give accurate response during the 300 ns discharge time of the cable PFL. These probe signals are recorded on a Tektronix 7784 dual beam oscilloscope which is triggered by the flash lamp signal. The flashlamp characteristic is monitored by a photomultiplier tube viewing the flash through an observation port. Gas pressure and flow is monitored by an electronic pressure gage and a flowmeter at the inlet to the switch housing.

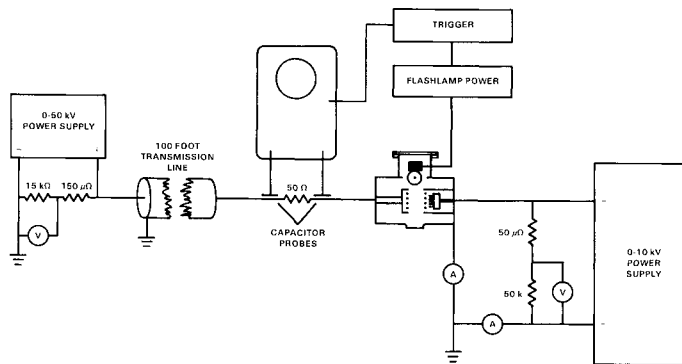

Fig. 4. Test set-up

B. Predischage Current Measurements

As attested by the lack of needle to cathode arcing, the needle array produces a broad, stable corona; no one needle carries an excess of current. The stability of the high pressure corona in SF_6 has been observed previously by R. Van Brunt.⁷ Thus it has been found possible to operate at needle voltages which are a significant fraction of the gap voltage, greatly enhancing the electron emission into the attachment region. The appearance of uniform cathode screen discoloration of the same size as the needle array indicates that the ion current is uniform, with area 3.4 cm^2 . Somewhat surprisingly, even after 1000 hours of corona, the needles were not severely blunted and no reduction of performance has been noted.

Figure 5 gives the measured current/voltage characteristic of the predischage ion current. The space charge limited

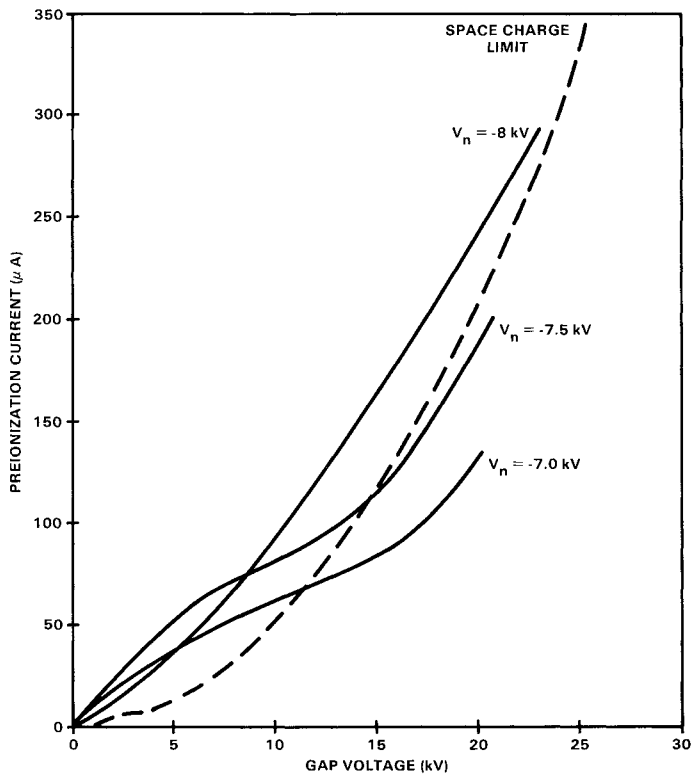

Fig. 5. Preionization current vs gap voltage for varying needle voltages. Pressure = 1.1 atm, gap spacing = .68 cm, needle-cathode spacing = .216 cm

prediction (using discharge area 3.4 cm^2 and ion mobility $0.5 \text{ cm}^2/\text{V-s}$) is included for comparison.

Especially at the higher needle voltages, the tendencies of the measured and calculated curves are the same, indicating that the test device is operating near the space charge limit. The pretriggered SF_6 number density using the analysis of section II.B is shown in Figure 6. The graph indicates a large electron source at the cathode screen. Integrating over the gap length indicates there are approximately 9×10^{10} ions in the gap.

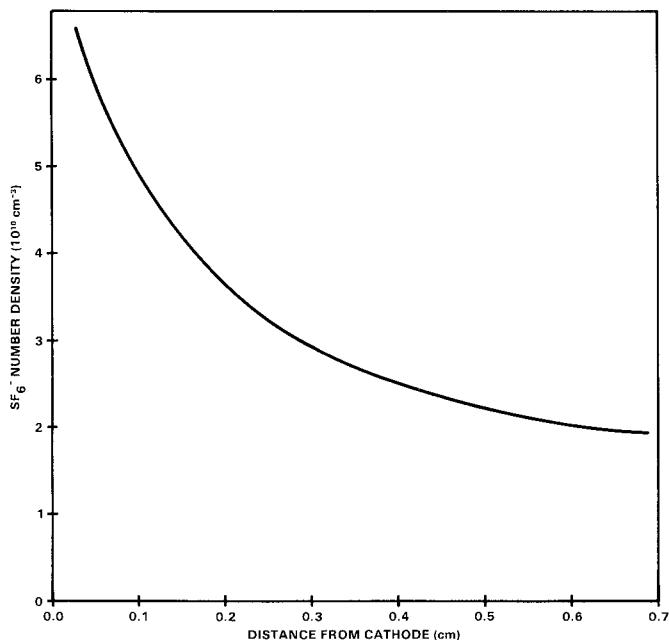

Fig. 6. Distribution of ion density. Total current = $250 \mu\text{A}$, gap voltage = 20 kV , needle voltage = -8 kV .

C. Triggering Characteristics

The next experiments were designed to test the photo-detachment concept. The self breakdown voltage of the space charged gap was typically 20% lower than the uncharged gap. This demonstrates that space-charging does not seriously compromise the insulating properties of the gas. The self-break probe signals indicated that the gap immediately transitioned into the spark mode with no temporary diffuse phase.

Attempts at photoinitiating the diffuse discharge so far have proved unsuccessful in disclosing any photo-current. The capacitor probe sensitivity limited the resolution of photo-activated current to above 5 A which would correspond to a gap on "impedance" of more than $200 \Omega/\text{cm}^2$. Current gains below 2.5×10^4 times the ion current level of 200 microamperes could not be discerned. Since current gains of about a million will be required for practical pulse power applications, the stated probe sensitivity is quite adequate for feasibility demonstration. Clutter introduced into the probe circuit from the flashlamp discharge is the major factor limiting probe sensitivity.

The fact that we were never able to initiate observable current levels tends to support the comment made in Reference 2 that the threshold for photo-detachment in SF_6 lies above 3.25 eV . The results are also consistent with the work

of Van Brunt and Misakian,⁸ even though we used more intense light and higher photon energies.

Significantly, the flash tube has never observed to initiate the spark discharge even when the space-charged gap was charged to 98% of the self-break value. This was an encouraging result.

IV. Future Plans

Our results so far indicate that more light at higher frequency will be required to switch the space charged gap. Two methods to accomplish this will be attempted. First, a large flashlamp pulser will be constructed to increase the illuminance. Second, an attempt will be made to see if the needle array can be operated as a light source by impressing a 100 ns pulse onto the dc needle current.

Acknowledgement

The authors would like to acknowledge the work of Vernon Walker who constructed the apparatus and assisted in the measurements. Mr. Walker passed away during the course of this work and this paper is respectfully dedicated to his memory.

References

1. L. G. Christopherou, "Electronegative Gases" in *Electrical Breakdown and Discharges in Gases*, Part A, ed. by Kuhnhardt and Luessen, Plenum Press, New York, N.Y., 1983.
2. P. J. Hay, "The relative energies of SF_6^- and SF_6 as a function of geometry." *JoChem. Phys* 76(1). January 1982.
3. D. Hansen, H. Jungblut, W. F. Schmidt, "Electron detachment from negative ions in sulphur hexafluoride." *J. Phys. D: Appl. Phys.* 16 (1983).
4. G. E. Streit, "Negative ion chemistry and the electron affinity of SF_6 ," *J. Chem Phys* 77(2). July 1982.
5. G. Schaefer, P. F. Williams, K. H. Schoenbach and J. Moseley, *Proc. of the 35th Gaseous Electronics Conference*, *Bull. Am. Phys. Soc.* 28, 172 (1983).
6. M. Giesselmann, W. Pfeiffer, J. Wolf, "Nanosecond pulsed breakdown of N_2 and SF_6 ," *IEEE Proc. of conference on Electrical Insulation and Dielectric Phenomena*, Claymont DE, October 1984.
7. R. J. Van Brunt, private communication.
8. R. J. Van Brunt and M. Misakian, "Role of photo detachment in initiation of electric discharges in SF_6 and O_2 " *J. Appl. Phys* 54(6), June 1983.