

TESTING AND OPTIMIZING ACTIVE ROTARY FLUX COMPRESSORS*

B.M. Carder, D. Eimerl, E.J. Goodwin, J. Trenholme, R.J. Foley

University of California, Lawrence Livermore National Laboratory, Livermore, CA 94550

W.L. Bird

University of Texas, Austin, Center for Electro-Mechanics, Taylor Hall 167, Austin, TX 78712

Summary

The test program for an Active Rotary Flux Compressor (ARFC) has demonstrated conclusively that large compression factors can be obtained with a laminated-iron, wave-wound, rotary flux compressor. Peak-current to startup-current ratios of 17 have been produced with a rotor tip speed of 60 meters per second. Sub-millisecond pulse widths were also measured: The minimum, 590 μsec (FWHM), was obtained at 5607 rpm with an 8-inch diameter, 4-pole rotor. The machine was operated without a high current output switch, proving the feasibility of a novel commutation scheme described.

A computational code has been developed that will calculate the output waveshape of the model ARFC with reasonable accuracy. The code is being refined to better account for saturation in the iron laminations. A second optimization code selects the best design for a given application. This code shows favorable cost effectiveness of large ARFC's over the conventional capacitors to drive flashlamps for large lasers.

Introduction

A four-pole ARFC with an 8-inch rotor diameter was constructed and tested at the University of Texas at Austin (UT). The test results compare favorably with a computational model developed jointly between UT and the Lawrence Livermore National Laboratory (LLNL). This model is also being used in an optimization code at LLNL that dimensionally and electrically compares machines to produce the optimum point design for a particular machine application.

This program is part of a continued effort to reduce the cost and improve the reliability of large (10-100 megajoule) energy storage systems that will produce high power (10-100 gigawatt) discharges. The current work with these rotating-mass energy stores has proven that rotary flux compression is a viable option for producing single or multiple sub-millisecond electrical pulses of very high power.

Test Machine Construction

The 8-inch ARFC has a wave wound rotor, with a matching wave winding on the stator¹. The stator winding provides the machine with a very low inductance return path when the rotor is turned to the fully compensated position. Both the rotor and the stator are constructed with laminated iron. This laminated iron increases the maximum inductance in the uncompensated position by an order of magnitude over that obtained if it were not used. Thus the machine has a very high maximum to minimum inductance ratio.

*Work performed under the auspices of the U.S. Department of Energy by the Lawrence Livermore National Laboratory under contract no. W-7405-Eng-48.

The machine is wound with 12 turns on each of three poles and 11 turns on the fourth, or 47 turns total. The missing turn enables electrical connections to be made with no crossing of the conductor wires. The 14 mil iron laminations on both rotor and stator are stacked one foot high. The overall length of the rotor is 19.75 inches and its moment of inertia is 0.39 kg m^2 . The maximum to minimum inductance ratio is 45, with minimum inductance of 24 μH in the compensated position.

Test Results

The 8" machine was operated to 5682 rpm maximum. "Seed" current was provided by a bank of from one to four $\sim 188 \mu\text{F}$ capacitors, charged to 3 kV maximum. The test circuit is shown in Figure 1. The "load" for this test was a loop of #6 gage cable, 36 inches long. A diode was used to bypass the current around the startup capacitor after it has discharged.

To date, the machine has achieved a ratio of 17 between the seed current and the peak current output. The highest peak current was 25.6 kA at 5682 rpm. The minimum pulsewidth achieved is 590 μsec (FWHM) at 5607 rpm, with one startup capacitor in the circuit.

A summary of the test results is given in Table 1. Note that the pulsewidth increases as the startup capacitance increases, and it decreases as the speed increases. These effects are expected because 1) a higher capacitance means a longer startup time constant and 2) higher speed naturally produces a shorter pulse. A slightly wider pulse is observed with higher startup capacitor voltage, and this is believed to be due to the iron saturating earlier with a higher current pulse.

The product of the current pulse ratio times the halfwidth is given in the last column of Table 1. This product appears reasonably constant, trending slightly downwards as the speed increases. Thus the current pulse ratio increases as the pulse halfwidth decreases.

Computational Model

The computational code calculates the inductance and eddy resistance variations with machine angle by use of a space harmonic model developed initially at UT² and modified at LLNL. The code also calculates the radial and tangential stresses, the electrical stress in the windings, and the mechanical forces due to the magnetic flux density. The diffusion of current into solid pole pieces (if present) is also calculated, and the effects of iron saturation is now being investigated.

The code can be used for modeling many of the machine types now being considered, including active and passive rotary flux compressors with either laminated or solid stators. It can also model a

Report Documentation Page

Form Approved
OMB No. 0704-0188

Public reporting burden for the collection of information is estimated to average 1 hour per response, including the time for reviewing instructions, searching existing data sources, gathering and maintaining the data needed, and completing and reviewing the collection of information. Send comments regarding this burden estimate or any other aspect of this collection of information, including suggestions for reducing this burden, to Washington Headquarters Services, Directorate for Information Operations and Reports, 1215 Jefferson Davis Highway, Suite 1204, Arlington VA 22202-4302. Respondents should be aware that notwithstanding any other provision of law, no person shall be subject to a penalty for failing to comply with a collection of information if it does not display a currently valid OMB control number.

1. REPORT DATE JUN 1981		2. REPORT TYPE N/A		3. DATES COVERED -	
4. TITLE AND SUBTITLE Testing And Optimizing Active Rotary Flux Compressors				5a. CONTRACT NUMBER	
				5b. GRANT NUMBER	
				5c. PROGRAM ELEMENT NUMBER	
6. AUTHOR(S)				5d. PROJECT NUMBER	
				5e. TASK NUMBER	
				5f. WORK UNIT NUMBER	
7. PERFORMING ORGANIZATION NAME(S) AND ADDRESS(ES) University of California, Lawrence Livermore National Laboratory, Livermore, CA 94550				8. PERFORMING ORGANIZATION REPORT NUMBER	
9. SPONSORING/MONITORING AGENCY NAME(S) AND ADDRESS(ES)				10. SPONSOR/MONITOR'S ACRONYM(S)	
				11. SPONSOR/MONITOR'S REPORT NUMBER(S)	
12. DISTRIBUTION/AVAILABILITY STATEMENT Approved for public release, distribution unlimited					
13. SUPPLEMENTARY NOTES See also ADM002371. 2013 IEEE Pulsed Power Conference, Digest of Technical Papers 1976-2013, and Abstracts of the 2013 IEEE International Conference on Plasma Science. Held in San Francisco, CA on 16-21 June 2013. U.S. Government or Federal Purpose Rights License.					
14. ABSTRACT					
15. SUBJECT TERMS					
16. SECURITY CLASSIFICATION OF:			17. LIMITATION OF ABSTRACT	18. NUMBER OF PAGES	19a. NAME OF RESPONSIBLE PERSON
a. REPORT unclassified	b. ABSTRACT unclassified	c. THIS PAGE unclassified			

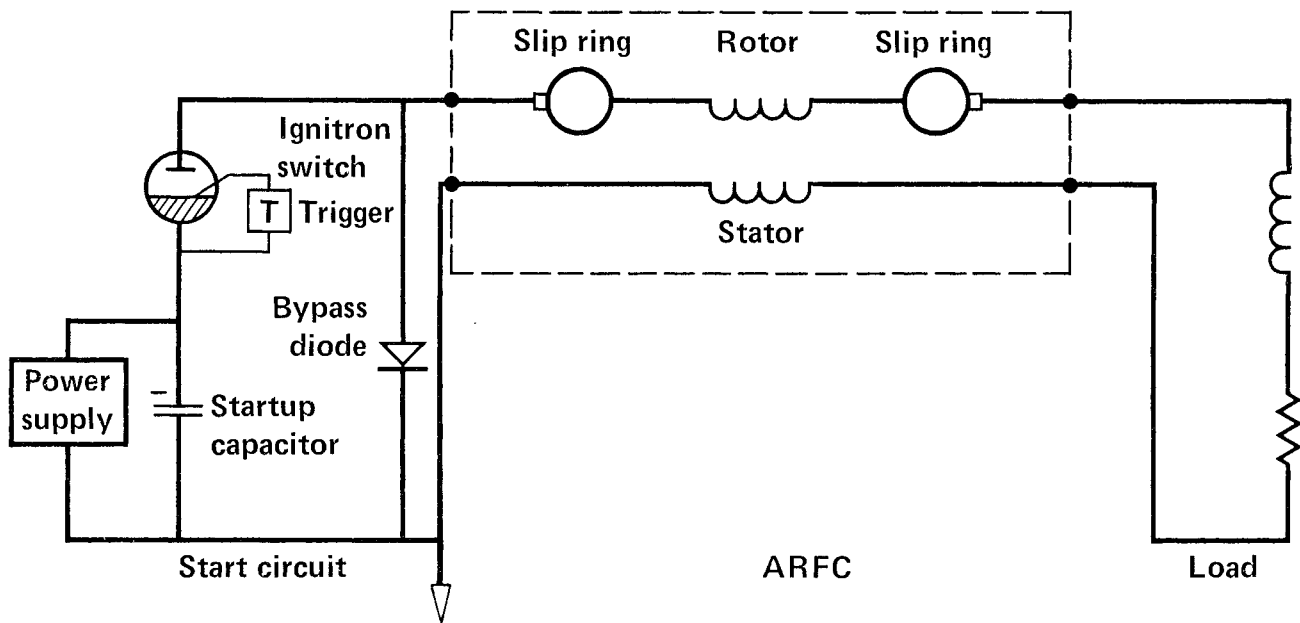

FIGURE 1. Test circuit for the active rotary flux compressor (ARFC). The startup capacitor provides initial "seed" current to the ARFC. When it is discharged, the diode bypasses the startup circuit for the high current compressed pulse.

TABLE 1 8-INCH ARFC TEST RESULTS

RUN NO.	MACHINE SPEED	STARTUP CAPACITOR		CURRENT PULSE				
		Capacitance	Charge Voltage	Seed Current	Peak Current	Ratio	Halfwidth (FWHM)	Ratio Times FWHM
	rpm	(μ F)	(kV)	(A)	(A)		(msec)	(msec)
25	2143	182	2.0	690	5060	7.3	1.93	14.1
26	3109	182	2.0	740	8300	11.2	1.15	12.9
27	3077	369	2.0	1090	11260	10.3	1.30	13.4
28	3133	562	2.0	1390	13000	9.4	1.45	13.6
29	3158	754	2.0	1640	13620	8.3	1.53	12.7
30	3846	754	2.0	1800	17240	9.6	1.10	10.6
31	4124	754	2.0	1670	18200	10.9	1.12	12.2
32	4545	182	2.0	780	12040	15.4	0.73	11.2
33	5381	182	2.0	880	13590	15.4	0.60	9.2
34	5607	182	2.5	1010	17130	17.0	0.59	10.0
35	5671	182	3.0	1290	19540	15.1	0.67	10.1
36	5682	369	3.0	1810	25610	14.1	0.79	11.1

Compulsator (i.e., an ARFC with a field coil so that it is also an alternator). The purpose of the code is to provide accurate predictions of the dimensions and performances of large machines. In its present form, the code provides reasonably accurate representations of the 8" ARFC model.

Comparison of Test Results with Computation

The current pulse was measured with a Pearson Model 301X current transformer and digitized with a Nicolet Model 1090 A oscilloscope. These data for run numbers 27, 31 and 36 (see Table 1) are presented graphically in Figure 2.

Overlaid on the measured current curves are the calculated currents derived by the computer. The comparison shows that the measured pulsewidths are slightly greater than those calculated. The discrepancy is believed to be caused by incorrect modeling of the iron saturation. The measured current is also seen to pass through zero. This is an artifact of the current pulse transformer, and it is not real.

Cost Optimization

The present goal of the program is to estimate the costs and to provide the design details of large machines optimized for specific purposes. For example with the LLNL solid state laser requirement, a machine of 5 to 20 megajoules output is desired for powering flashlamps with a half to one millisecond pulse.

In order to satisfy this LLNL requirement, a flashlamp model has been added to the computational program. This model includes the non-linear flashlamp as well as the external circuit to the machine. Another algorithm calculates the relative number of inversion centers produced as the flashlamp energy pumps the lasing medium, taking in account any spontaneous decay. Thus the complete code can provide relative gain, the energy delivered to the flashlamps at peak gain, the total energy delivered to the flashlamps, and/or any other output parameter required plus all of the parameters of the machine.

Because the code will provide the physical dimensions for any machine that it calculates, it is possible to estimate the cost. Comparison of this cost to a given performance parameter provides a figure of merit for the machine. For example, if a given ARFC is estimated to deliver W joules of energy to the flashlamps at a cost (including startup capacitors) of c cents, then a figure of merit, $M = c/W$ cents per joule, would be obtained. The purpose, of course, is to estimate the possible cost saving over present (capacitor powered) technology for a large high power energy store.

Because a large number of variables are interwoven into the calculation of these machines, it is impractical to hand-feed the computer the inputs for every run in order to reach the optimum machine design. A similar multi-variable problem for optimizing the design of a large laser has been resolved with a computational technique called "Creeper"³. This technique has been adapted for optimizing the ARFC's and Compulsators.

With the creeper routine, the desired task, e.g., "minimize cents per joule" is given to the computer. A starting point, or initial design is also provided. The computer then calculates machines, and is able to point itself toward lower cost, or optimum

designs. When it can reduce the result no farther it stops, and provides its best answer.

Any number of constraints can be used in the routine, so that the final answer will be meaningful. For the ARFC/flashlamp program, the constraints include: rotor tip speed, mechanical shear stress, dielectric stress in the insulation, temperature rise in the conductors, magnetic pressure, rotor mechanical deflection, and terminal voltage. An example of an optimized design for a 4.5 megajoule machine is given in Table 2.

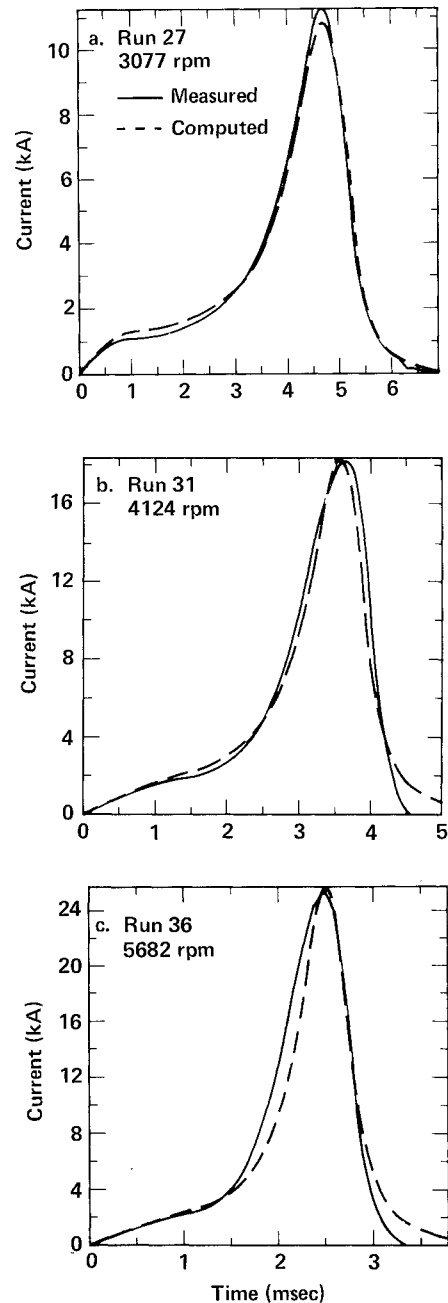

FIGURE 2. Comparison of measured and computed current output of the 8-inch ARFC.

"Switchless" ARFC Circuit

One of the great advantages of the ARFC over its cousin, the Compulsator, is that output switch recovery will not be a problem. In fact, by using the brushes to commutate the startup capacitor and the load into the circuit, the high current output switch is eliminated.

Since the Compulsator is also a generator (alternator), it will provide an output pulse on every cycle of the machine. If multiple-pulses, synchronized to the machine are not desired, then a switch must be used that will recover before the next cycle. This is a difficult requirement for a switch that must first pass a very high current, high coulomb pulse.

The ARFC will not multiple-pulse, except for a single 5-10% after-pulse if the circuit is not commutated. Because of this, the circuit can be greatly simplified. An example is given in Figure 3. Here a flashlamp load is triggered by the startup capacitor when the ignitron fires with the commutator in the position shown (i.e. when the startup capacitor circuit is connected to the ARFC and load circuit). After the startup capacitor has provided initial current to both turn on the flashlamps and "seed" the ARFC, the commutator shorts out the startup circuit. The ARFC then follows through, compressing this seed current, to drive the load with a high current pulse. At zero current, after the pulse, the commutator disconnects the machine, and operation ceases.

Note that the ignitron switch only needs to carry the startup current and not the ~20 times higher output current of the machine. Thus a single ~100kA ignitron could initiate a 2 megamp ARFC. The commutator itself becomes the high current output switch, and the rest of the circuit is "switchless".

TABLE II OPTIMUM ARFC FOR FLASHLAMPS

ENERGY		4.46 megajoules
ROTOR	DIA	0.847 meters
	LENGTH	0.765 meters
	INERTIA	417 joule-sec ²
NO. OF POLES		4
NO. OF TURNS		11
SPEED		1892 rpm
PULSEWIDTH		1.20 milliseconds
PEAK CURRENT		293 kiloamps
FLASHLAMP K		14.3 volts/amps ^{0.5}

References

1. M. Spann, W. Bird, W. Weldon, H. Rylander, H. Woodson, "The Design, Assembly, and Testing of an Active Rotary Flux Compressor", 3rd IEEE International Pulsed Power Conference, June 1981.
2. J.A. Parekh, W. Bird, A. Patel, H. Woodson, "Space Harmonic Analysis of Magnetic Fields in a Compensated Pulsed Alternator or an Active Rotary Flux Compressor", 3rd IEEE International Pulsed Power Conference, June 1981.
3. J. Nedler and R. Mead, Computer Journal, Vol. 7 pp 308 (1965).

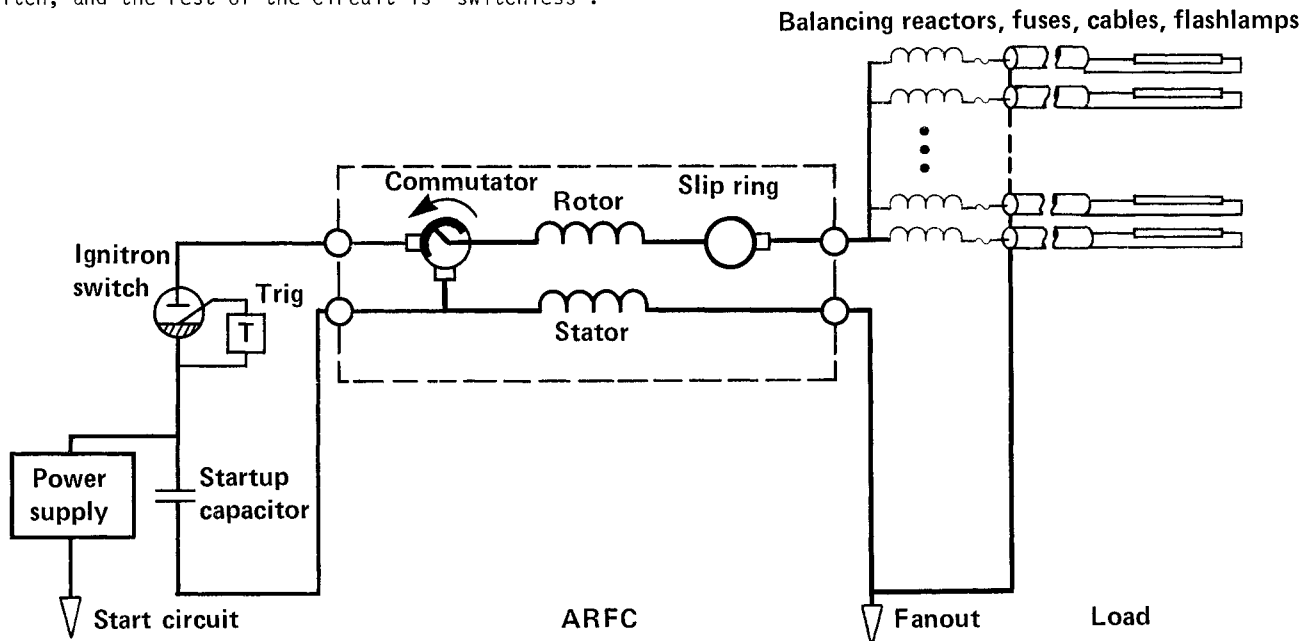

FIGURE 3. ARFC circuit to drive laser flashlamps. The circuit is timed so that the ignitron switch fires with the commutator in a position to connect the startup capacitor to the ARFC via the flashlamp loads. When the capacitor is discharged, the commutator connects the loads directly across the ARFC for the high current pulse. After the pulse, at current zero, the commutator opens the circuit, preventing any afterpulses.