

DESIGN OF A COMMAND-TRIGGERED PLASMA OPENING SWITCH FOR TERAWATT APPLICATIONS

M. E. Savage, C.W. Mendel, Jr., D.B. Seidel, R.W. Shoup*

Sandia National Laboratories[§]

PO Box 5800 Mail Stop 1194

Albuquerque NM 87185

Abstract

Inductive energy storage pulsed power systems can have high energy density, leading to smaller, less expensive systems. The crucial element of an inductive energy storage system is the opening switch. In microsecond and nanosecond pulsed power systems the plasma opening switch has been in use for more than twenty years. Though widely studied, application of the plasma opening switch (POS) has been limited in both performance and understanding.

The development of the triggered switch is aimed to address three important areas. First, complete de-coupling of the closed phase and the opening phase will allow improved performance, especially at longer conduction times. Second, the simplified physics allows for easier modeling because of a better-defined geometry. Third, naturally, triggering will reduce jitter of the output pulse. Improving performance will allow longer conduction time, and triggering will negate the naturally increased self-operating jitter at longer conduction time.

The triggered switch system is based on moving the plasma switch armature with a magnetic field. Up until the time the armature is pushed away, it is held in place against the drive current magnetic pressure by a second magnetic field. We have demonstrated the components of this system [1], but never before has a plasma opening switch been opened by an independent signal.

Our system is designed to deliver 1-2 terawatts of usable load power at multi-megavolt potentials. We define usable load power as the product of load voltage and load cathode (boundary) current. The length of the vacuum storage inductor defines the 35 ns pulse length. This paper will show the design of the switch and trigger system, which is conservatively designed to provide a wide range of trigger signals. The trigger power for this system is important for cost reasons. The first experiments will use a trigger level of ten percent of the output pulse; we will describe

design features intended to reduce the amount of trigger power needed. Particle-in-cell simulations of the active trigger will also be shown.

I. INTRODUCTION

The well-known advantages of inductive energy storage could allow smaller and more efficient pulsed-power drivers. Inductive energy storage systems allow lower voltage at the vacuum interface; the water pulse-compression elements and vacuum interface are significant cost and size items in high-power drivers. Because the opening switch is the point of highest voltage in an inductive storage design, it is the single most important part of such systems. Since its invention, the plasma opening switch [2] has been studied as an attractive pulse-compression element for pulsed-power applications [3]. A POS exploits the fact that plasma is an excellent conductor with low mass. The mass is important because the plasma must be moved rapidly to open the switch, and lower mass conductors require less energy to move. The fact that the POS operates in vacuum also allows magnetic insulation, with higher insulation strength than any other dielectric.

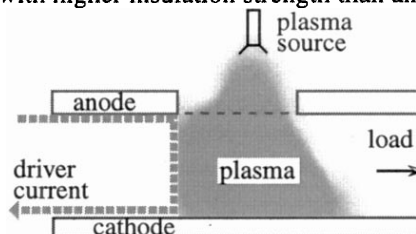

Figure 1. A simplified conventional plasma opening switch.

The POS is realized by injecting plasma from an external plasma source into the anode-cathode gap of a magnetically insulated transmission line. Figure 1 shows schematically a simplified plasma opening switch.

[§] Work performed at Sandia National Laboratories. Sandia is a multiprogram laboratory operated by Sandia Corporation, a Lockheed Martin Company for the United States Department of Energy under Contract No. DE-AC04-94AL85000.

*Defense Threat Reduction Agency, Kirtland Air Force Base, Albuquerque, NM

Report Documentation Page

Form Approved
OMB No. 0704-0188

Public reporting burden for the collection of information is estimated to average 1 hour per response, including the time for reviewing instructions, searching existing data sources, gathering and maintaining the data needed, and completing and reviewing the collection of information. Send comments regarding this burden estimate or any other aspect of this collection of information, including suggestions for reducing this burden, to Washington Headquarters Services, Directorate for Information Operations and Reports, 1215 Jefferson Davis Highway, Suite 1204, Arlington VA 22202-4302. Respondents should be aware that notwithstanding any other provision of law, no person shall be subject to a penalty for failing to comply with a collection of information if it does not display a currently valid OMB control number.

1. REPORT DATE JUN 1999		2. REPORT TYPE N/A		3. DATES COVERED -	
4. TITLE AND SUBTITLE Design Of A Command-Triggered Plasma Opening Switch For Terawatt Applications				5a. CONTRACT NUMBER	
				5b. GRANT NUMBER	
				5c. PROGRAM ELEMENT NUMBER	
6. AUTHOR(S)				5d. PROJECT NUMBER	
				5e. TASK NUMBER	
				5f. WORK UNIT NUMBER	
7. PERFORMING ORGANIZATION NAME(S) AND ADDRESS(ES) Sandia National Laboratories PO Box 5800 Mail Stop 1194 Albuquerque NM 87 185				8. PERFORMING ORGANIZATION REPORT NUMBER	
9. SPONSORING/MONITORING AGENCY NAME(S) AND ADDRESS(ES)				10. SPONSOR/MONITOR'S ACRONYM(S)	
				11. SPONSOR/MONITOR'S REPORT NUMBER(S)	
12. DISTRIBUTION/AVAILABILITY STATEMENT Approved for public release, distribution unlimited					
13. SUPPLEMENTARY NOTES See also ADM002371. 2013 IEEE Pulsed Power Conference, Digest of Technical Papers 1976-2013, and Abstracts of the 2013 IEEE International Conference on Plasma Science. Held in San Francisco, CA on 16-21 June 2013. U.S. Government or Federal Purpose Rights License.					
14. ABSTRACT Inductive energy storage pulsed power systems can have high energy density, leading to smaller, less expensive systems. The crucial element of an inductive energy storage system is the opening switch. In microsecond and nanosecond pulsed power systems the plasma opening switch has been in use for more than twenty years. Though widely studied, application of the plasma opening switch (POS) has been limited in both performance and understanding. The development of the triggered switch is aimed to address three important areas. First, complete de-coupling of the closed phase and the opening phase will allow improved performance, especially at longer conduction times. Second, the simplified physics allows for easier modeling because of a better-defined geometry. Third, naturally, triggering will reduce jitter of the output pulse. Improving performance will allow longer conduction time, and triggering will negate the naturally increased selfoperating jitter at longer conduction time.					
15. SUBJECT TERMS					
16. SECURITY CLASSIFICATION OF:			17. LIMITATION OF ABSTRACT SAR	18. NUMBER OF PAGES 5	19a. NAME OF RESPONSIBLE PERSON
a. REPORT unclassified	b. ABSTRACT unclassified	c. THIS PAGE unclassified			

The plasma short-circuits the transmission line, allowing magnetic energy to accumulate in the storage inductance upstream of the plasma opening switch. When the POS opens, the stored magnetic energy is transferred to the load. There are two effects that cause the initially closed POS to open: first, there is a magnetic pressure from the storage inductor current pushing on the plasma (which has no tensile or shear strength); second, there is ion depletion from the plasma due to voltage across a sheath. At typical plasma densities and magnetic fields, ion erosion is a relatively small effect. Unless field penetration is severe (see below), it is the axial force from the storage inductor current that causes opening in a conventional POS. The switch opens, rather than simply translating a slug of plasma, largely because the plasma mass density is non-uniform across the gap. To a lesser extent, there is plasma shearing due to the variation of magnetic field with radius in the coaxial transmission lines typically used. Because the opening mechanism (storage inductor current) is applied continuously while the switch is closed, it is solely plasma inertia that keeps the conventional switch closed. This means that keeping a switch closed for longer times requires higher plasma mass. For a given conventional POS geometry and drive current, one would expect the opening time to be (at least) proportional to the conduction time.

While the plasma is conducting current, it is possible for the drive current magnetic field to penetrate into the plasma. This is one problem with conventional switches in which the opening current is the same as the (relatively slow) drive current. The penetration mechanism is replacement of plasma electrons with flux-carrying electrons emitted from the cathode conductor. Because these electrons essentially drift in the $E \times B$ direction, this is often called Hall penetration [4]. The time scale for this penetration is

$$\tau \cong \frac{q_i n_i \text{Vol}}{I_{\text{conduction}}}, \quad (1)$$

where q_i is the plasma ion charge, n_i is the plasma ion density, Vol is the plasma volume through which current is conducted, and $I_{\text{conduction}}$ is the current conducted. If this time is comparable to the generator rise time, the magnetic field penetrates into the plasma. For example, with a relatively large 1 liter conducting volume of doubly-ionized plasma at 10^{21} ions/m³, this time is 320 ns at 1 MA drive current. Thus in many such experiments with 500 ns or longer drive times, there is considerable plasma mass left behind the magnetic piston. These ions are removed by acceleration across a sheath, at the expense of more energy than sweeping them in a magnetic sheath. Increasing the plasma ion number density reduces field penetration but raises the mass that must be moved for opening. A viable approach to improving opening switch performance would be to reduce the opening field rise time

so that penetration is unimportant for reasonable plasma densities.

In addition to opening time, another important parameter related to opening switches is the amount the switch opens. The fraction of the anode-cathode gap cleared of plasma determines the efficiency of the POS. One way to infer the effective gap cleared of plasma is to measure voltage and electron flow downstream of the POS and compute the consistent vacuum impedance. This technique is a flow impedance [5, 6] calculation. The flow impedance of a section of magnetically insulated transmission line is

$$Z_f = \frac{V}{\sqrt{I_{ua}^2 - I_{dc}^2}} \quad (2)$$

where Z_f is the flow impedance, V is the voltage, I_{ua} is the anode current upstream of the section and I_{dc} is the cathode current downstream of the section.

Flow impedance considers axial electron flow, which is important in magnetically insulated systems. For this reason, flow impedance may be used as a measure of opening switch performance, instead of other commonly used parameters such as voltage or resistance. For efficiency, the effective impedance of the opening switch must be higher than the load impedance, so it is the load and not the opening switch that determines voltage. Another common technique is modeling the POS as a radial resistor. This is not generally useful because the calculated resistance varies dramatically with both load impedance and current monitor location, due to axial current flow in vacuum-flowing electrons.

A desirable opening switch for an inductive energy store system is one that opens quickly compared to the output pulse width, and opens far enough to allow efficient energy transfer to the load. Further, since the POS is the final stage of pulse compression, a system that allows temporal synchronization of the output pulse is also desirable. The command-triggered plasma opening switch described below is designed to improve performance as well as introduce the ability to actively trigger its opening.

II. THE COMMAND-TRIGGERED PLASMA OPENING SWITCH

The Magnetically Controlled Plasma Opening Switch (MCPOS) relies on the fact that at typical plasma densities and magnetic fields, it is magnetic pressure that causes a POS to open. The MCPOS [1] uses an additional magnetic field created by diverting storage inductor current into a helical coil assembly located in the switch region; when so diverted this coil is in series with the storage inductor cathode. The inductance of this coil is small compared to the storage inductance, but raises the magnetic field by a factor of 3 in the switch region. This gives nearly an order of magnitude higher magnetic field pressure on the plasma, which increases

the amount the switch opens. This additional field is zero until the helical field coil is energized, and then ideally rises much faster than the storage inductor current. The extension of those experiments is to drive the fast coil with an external pulser.

Figure 2 shows the concept of the command-triggered plasma opening switch. An applied magnetic field (5-10 kJ of field energy delivered in 1 msec) guides plasma into the transmission line anode-cathode gap. This field also holds the plasma in place, countering the impulse from the drive current pressure. While the plasma conducts the driver current, electron replacement field penetration occurs to some extent; however, the plasma density will be chosen such that the voltage drop will be less than a few kilovolts before the switch opens.

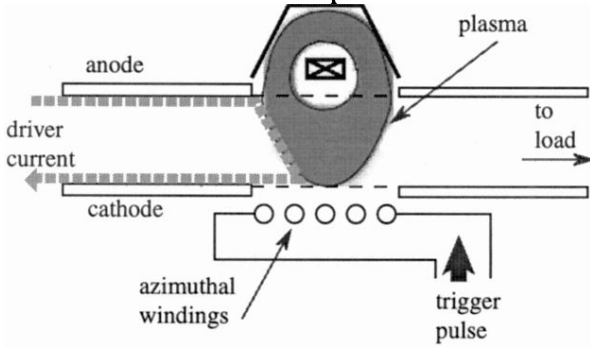

Figure 2. The triggered opening switch concept. Plasma is held in place by an applied magnetic field. The closed condition is shown.

Application of the trigger pulse energizes the azimuthal windings (the ‘fast coil’). This coil’s azimuthal current causes a radial force on the plasma surface. This trigger field has a rise time 5-10 times faster than the storage inductor current. Whereas the storage inductor current might have penetrated substantially into the plasma, the trigger field’s penetration is negligible because of its relatively fast rise time. This separation of conduction and opening is the central part of this work.

Opening a POS by this method would be effective, yet it will be seen below that the trigger energy depends strongly on the amount the switch is opened. A high-performance system is one in which the POS opens relatively far. For this reason, our experiment uses a stage of amplification. The fast coil drive power is less than the load power; this system has power gain. Therefore, the trigger power can be reduced with an additional stage. The system we will describe is one in which the triggered switch diverts storage inductor current into the fast coil of a second plasma opening switch. The gain of this system reduces the required trigger power significantly.

III. CALCULATIONS

A set of calculations shows the approximate energy required to trigger the switch. Because of the fast rise time of the trigger field, we will ignore field penetration.

The first requirement is that the magnetic field pressure be adequate to push the plasma. A pressure-balance calculation shows that the magnetic field must be

$$B \geq v_{\text{sheath}} \sqrt{2\mu_0 n_0 m_i} \quad (3)$$

Here B is the magnetic field at the plasma surface, v_{sheath} is the magnetic piston velocity, μ_0 is the permeability of space, n_0 and m_i are the plasma number density and ion mass, respectively. Note that the plasma density required stems from allowing replacement of half or less of the plasma electrons; essentially we require that the electron charge in the plasma be at least twice the charge in the storage inductor current pulse, up to the time of peak current (Eq. 1). For a sheath velocity consistent with 2 cm in 50 ns, the magnetic field must be about 0.5T.

Second, the trigger pulser must supply the energy to move the plasma and fill the volume with magnetic field. With a constant magnetic field B_0 , the energy to increase the field volume is

$$E = \eta \frac{B_0^2}{\mu_0} \text{Vol}, \quad (4)$$

with

$$\frac{1}{2} \leq \eta \leq 1 \quad (5)$$

Vol is again the plasma volume. The factor η depends upon the final energy distribution between kinetic and magnetic energy; for a fast-moving system η will be closer to 1. Using the 0.5T from Eq. 3 and the 16 liter plasma volume, the maximum energy is 3.2 kJ. This is also an upper bound on energy required because the entire plasma volume will not be displaced. To judge the value of an additional stage, we can use Eq. 4 to compute the energy needed for the main switch. The main switch must open farther and faster; using an amplifier stage allows triggering with 2.6 kJ instead of 14 kJ required by the main switch.

With this estimate of the driver requirements, the system design could begin. The fast field coil could be designed with a magnetostatic model because of negligible field penetration. A planar coil with 28 vanes in parallel, each making a quarter-turn gives a vacuum inductance of 32 nH. The coil is constant-pitch, with vanes everywhere having the same angle from radial. With plasma pushed completely out of the gap, achieving 0.5 T at the anode requires 430 kA in this coil. The inductance under this condition is 26 nH. The field energy at 430 kA is 2.4 kJ with plasma present; with no plasma the energy is 3.0 kJ.

IV. TRIGGER DESIGN

The trigger pulser supplies the current that energizes the fast field coil. The resulting magnetic field applies a radial force to the plasma, which causes opening. As shown before, the energy required is a few kilojoules in 50 ns. This is approximately 0.06 TW. Present

technology makes this readily available. Since this is a basic experiment, the pulser design allowed for more than the minimum energy. The pulser uses available components from other experiments. A 24-stage, 100 kV Marx generator charges 2 parallel 7.5 nF water capacitors. A megavolt gas switch transfers this energy into 4 parallel 7.8Ω water pulse-forming lines. The pulse-forming lines use self-closing water switches. The output of these pulse forming lines feeds through a graded vacuum interface into the fast coil. This pulser can supply more than 800 kA into the fast coil and has over 20 kJ available.

V. MECHANICAL DESIGN

Figure 3 shows the layout of the triggered POS. The storage inductor is 17Ω coaxial vacuum line (not shown) on the left side of the figure. The load is an electron-beam diode (also not shown) to the right of the figure. Typical load impedance ranges from 6-12 Ω . The storage inductor is 250 nH and the peak current is 800-900 kA. The goal is to energize the main (second) POS fast coil in 10-20 ns.

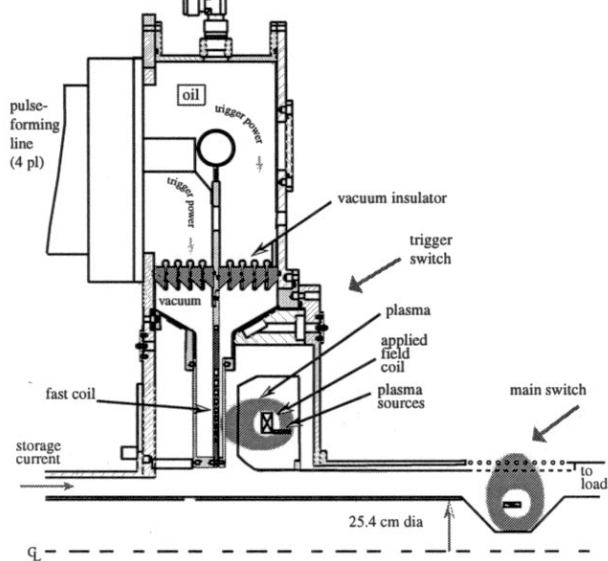

Figure 3. Cross-sectional view of the amplified-trigger POS.

VI. SIMULATIONS

Particle-in-Cell simulations of the command-triggered POS have been run using the $2\frac{1}{2}$ D code TwoQuick [7]. A new model was added to TwoQuick that uses a tensor conductivity layer in the plane of the fast coil to properly account for the coil's current in 2D. These simulations (whose geometry, initial plasma, and slow B field are shown in Figure 4) include the double-sided fast coil feed as in the experiment, and use an electron diode load in place of the fast coil of the main switch. To calculate the simulations on a practical time scale, and to avoid problems due to numerical heating, the simulations are run on a timescale about one order of magnitude faster than the

experiment. The plasma mass density is about two orders of magnitude lower (1.0 C/m^3 , 1 amu ions), and the fields strengths (and currents) are about half those of the experiment (0.5 MA). The cell size in the plasma region is 0.5 mm and is chosen as a compromise between minimizing numerical heating and maintaining reasonable simulation cost.

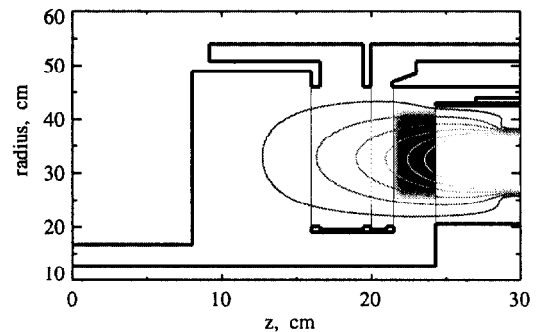

Figure 4. The simulation geometry. The fast field coil is shown and on either side of the fast coil are radial vanes (thin lines) that return the fast coil current. The applied field flux lines are shown, as is the plasma fill.

Figure 5 shows the upstream anode current, the downstream anode and cathode currents, and the fast coil (trigger) current from the simulation. For this simulation, the driver voltage is a step wave with one nanosecond risetime; the slow field is 0.2 T at the cathode surface. The trigger signal to the fast coil has a short-circuit current of 0.25 MA. It begins to rise at 1.0 ns after the simulation begins, but does not reach appreciable current until about 15 ns. The data in Fig. 5 give a flow impedance that reaches well above 3.0Ω . This is quite good considering the 4.0Ω vacuum impedance downstream of the switch.

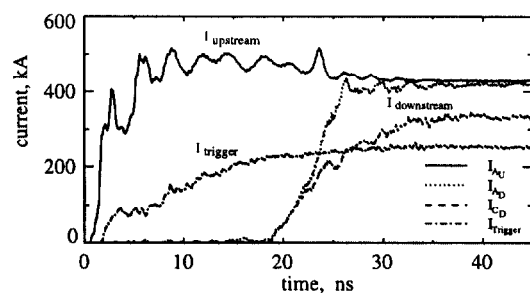

Figure 5. Simulation currents.

To test for contributions to opening from non-physical (numerical) effects, the fast coil drive was delayed to 10 ns, i.e. 9 ns later than above. Nothing else was changed. The delayed fast coil trigger signal resulted in a delayed switch opening (measured by flow impedance), but the rate of rise and the level of opening remained the same. If numerical heating of the plasma were a significant contributor to the simulation results,

significant differences would be expected in this comparison.

For efficiency and cost reasons it is desirable to minimize the trigger current supplied to the fast coil. To understand the effect of varying this current, simulations were performed at three trigger current levels: 125 kA, 250 kA, and 500 kA (25%, 50%, and 100% of drive current). In each case the slow field was adjusted in proportion to the trigger current. In each simulation, the flow impedance reaches about 3.5Ω , however the 125 kA case takes significantly longer to open. The 500 kA case opens slightly faster than the 250 kA case, but not enough faster to be worth the cost. It is likely that a current lower than 250 kA would suffice, but 125 kA appears to be too low.

As discussed earlier, flow impedance is an important metric of switch performance. To demonstrate this, the 250 kA trigger current case was repeated, varying the gap of the load diode. The gaps chosen for the three simulations performed correspond to 1.45Ω , 2.67Ω , and 4.00Ω vacuum impedance, respectively. Figure 6 shows the flow impedance for these three cases. The 1.45Ω load impedance data are noisy because the denominators involve a small difference between two large signals. Clearly, the figure shows that the switch flow impedance is independent of the load impedance. In contrast to the flow impedance, the switch impedance is seen to change drastically with load impedance. Clearly flow impedance is a better metric for a POS and supports the theoretical prediction that the switch flow impedance should be independent of load impedance.

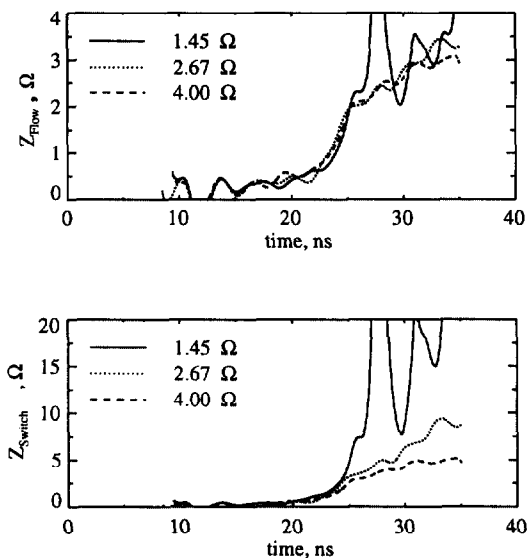

Figure 6. POS flow impedance (upper frame) and calculated resistance (lower frame) for three different load impedance values. The calculated resistance depends on load impedance, whereas flow impedance essentially does not. Note the different vertical scales.

VII. SUMMARY

Physical considerations and computer modeling show that a command-triggered plasma opening switch is practical. This switch has advantages in its separation of conduction and opening. The independent trigger has a rise time fast enough to avoid detrimental field penetration due to electron replacement. Because of this system's power gain, we reduce the trigger power by using a POS as an amplifier. With this amplification, the required trigger energy will be a few kJ for a 100 kJ system.

The expected performance of the trigger stage would rapidly switch all the storage inductor current into the main switch fast coil, providing the needed large and fast-rising magnetic pressure for rapid opening.

The simulations indicate that the balance in radial position and in magnetic field strengths between the fast and slow coils is important for obtaining high open flow impedance. The switch, when properly designed, appears to have excellent open flow impedance and opening speed. Simulation data show dramatically that the critical parameter of such a switch is the flow impedance, which is found to be independent of load impedance, whereas the switch resistance varies greatly depending upon the load. We have confidence in the experiment based on physical considerations and simulation results.

References

- [1] M. E. Savage, E. R. Hong, W. W. Simpson, and M. A. Usher, "Plasma Opening Switch Experiments at Sandia National Laboratories," presented at 10th International Conference on High Power Particle Beams, San Diego, California, 1994.
- [2] C. W. Mendel, Jr. and S. A. Goldstein, "A fast-opening switch for use in REB diode experiments," *J. Appl. Phys.*, vol. 48, pp. 1004-1006, 1977.
- [3] Special issue on fast opening vacuum switches, *IEEE Trans. Plasma Sci.*, vol. PS-15, 1987.
- [4] S. B. Swanekamp, J. M. Grossman, A. Fruchtman, B. V. Oliver, and P. F. Ottinger, "Particle-in-cell simulations of fast magnetic field penetration into plasma due to the Hall electric field," *Phys. Plasma*, vol. 3, pp. 3556-3563, 1996.
- [5] C. W. Mendel, Jr. and S. E. Rosenthal, "Modeling magnetically insulated devices using flow impedance," *Phys. Plasmas*, vol. 2, pp. 1332-1342, 1995.
- [6] C. W. Mendel, Jr., M. E. Savage, D. M. Zagar, W. W. Simpson, T. W. Grasser, and J. P. Quintenz, "Experiments on a current-toggled plasma-opening switch," *J. Appl. Phys.*, vol. 71, pp. 3731-3746, 1992.
- [7] J. P. Quintenz, D. B. Seidel, M. L. Kiefer, T. D. Pointon, R. S. Coats, S. E. Rosenthal, T. A. Mehlhorn, M. P. Desjarlais, and N. A. Krall, "Simulation Codes for Light-Ion Diode Modeling," *Laser and Particle Beams*, vol. 12, pp. 283-324, 1994.