

**TESTS ON PHOTOCONDUCTIVE SEMICONDUCTOR SWITCHES FOR SUBNANOSECOND
RISETIME, MULTIMEGAVOLT PULSER APPLICATIONS***

*V.B. Carboni, I.D. Smith
Pulse Sciences, Inc.
San Leandro, CA 94577*

*R.M. Pixton, M.D. Abdalla
BDM Management Services Company
Albuquerque, NM 87185*

*F.J. Zutavern, G.M. Loubriel, M.W. O'Malley
Sandia National Laboratories
Albuquerque, NM 87185*

ABSTRACT

Experiments were performed to determine the applicability of photoconductive semiconductor switches (PCSS) for use as output switches in subnanosecond pulse for EMP simulators. Lateral switches made of both Gallium Arsenide and Silicon with 1.5 cm long insulating regions immersed in Fluorinert were tested in a 50 ohm tri-plate transmission line geometry. Mode locked and Q-switched lasers were used to trigger both a gas switched Marx generator which pulse-charged the transmission line in 100-150 ns and to illuminate the PCSS via an optical delay line. Illuminating beam energies and electric field strengths at switchout were varied to determine minimum risetimes and light energies required for triggering. The GaAs switches were operated in the high gain (lock-on) mode. Risetimes as fast as 600 ps were observed using a mode locked laser and 700 ps using a Q-switched laser. The minimum light energy required to trigger GaAs was 22 μ J and the highest switched fields for both GaAs and Si is about 60 kV/cm.

INTRODUCTION

Existing electromagnetic pulse (EMP) generators generally produce pulses with risetimes in the range of 5-10 ns. This limitation in risetime is brought about primarily by the inductance associated with a single arc channel output switch. If simulators are to produce faster risetimes and higher radiated field levels, a means of overcoming these risetime limitations must be developed. Unfortunately, higher radiated fields require higher voltages to be switched which equates to larger switch gaps and consequently, higher switch inductance and slower risetime.

To overcome this limitation, Dr. Carl Baum of the Phillips Laboratory (PL) has suggested using multiple or distributed switches arranged in a series and parallel array which can be operated synchronously but at lower individual voltages and inductances yielding a lower composite risetime. A recent study^[1] has shown the feasibility of constructing such a distributed switch array whose risetime has no obvious limitations associated with voltage. The risetime of the distributed switch is ultimately determined by individual switch jitter.

If such a distributed switch were to use gas-insulated spark gaps, with individual jitter of 1.5 ns, the radiated risetime would be ~ 5 ns. Thus, to achieve subnanosecond risetimes for the distributed switch, faster individual switches with very low jitter must be developed. An attractive candidate is the PCSS which has been under development at Sandia National Laboratories (SNL) and others for several years.

In the PCSS, a nonconducting or weakly conducting solid is turned into a bulk conductor by laser illumination. For typical fast risetime switching applications, conduction must turn on in less than 1 ns and continue for 1 μ s or more. Several modes of operation are possible. With a material such as Gallium Arsenide (GaAs) at moderate fields (below 4-8 kV/cm) where the carrier lifetime is much shorter than 1 μ s, the laser pulse must persist for the entire conduction time at an intensity high enough to create sufficient carriers to keep the impedance low compared with that of the wavelauncher. This is called the linear mode. For a material such as silicon where the carrier lifetime is much longer than 1 μ s, the laser pulse needs to produce these carriers only once, in a time shorter than the desired pulse risetime. At higher field levels in GaAs, another mode of operation is possible, called lock-on. In this mode, the laser pulse produces a smaller number of carriers which trigger a gain mechanism within the material to produce the desired low impedance. These three modes require progressively less laser energy, and so are progressively more desirable provided the other requirements of fast switching can be met. The modes investigated in this experiment were long lifetime in silicon and lock-on in GaAs.

In silicon, current carriers are produced within the penetration distance of the light from the surface, and thus results in a thin sheet conductor of relatively low inductance. The light energy needed from a Nd:YAG laser to lower silicon resistance to a value Z is governed by the equation $Z = 1.3 \ell^2/W$ (in mohms) where ℓ is the length in centimeters and W is the light energy in joules. The energy is independent of the switch width. The 10-90% risetime of the switch is then determined by the time it takes to illuminate the switch with enough light energy to reduce its resistance to a value < 10% of the circuit load impedance.

For GaAs to operate in the lock-on mode, the field across the switch must be higher than the lock-on field of ~ 8.5 kV/cm. Further, the light energy used to trigger the switch must be above a threshold dependent on the applied field strength. Below these thresholds, GaAs operates in the linear mode.

Most previous work with both GaAs and Si switches has been performed with pulses having durations of a few microseconds or more to switchout. For long pulse operation, typical operating fields in tests at SNL have been as high as 50 kV/cm. Pulse charge times typical of EMP simulation are on the order of 100 ns and thus motivated this experiment to determine if such a shorter pulse duration would enable operation of the PCSS at higher field strengths. For Si, this would substantially lower light energy requirements

*This work was supported by Weapons Lab Contract No. F29601-87-C-0201 and U.S. Department of Energy Contract DE-AC04-76DP00789.

Report Documentation Page

Form Approved
OMB No. 0704-0188

Public reporting burden for the collection of information is estimated to average 1 hour per response, including the time for reviewing instructions, searching existing data sources, gathering and maintaining the data needed, and completing and reviewing the collection of information. Send comments regarding this burden estimate or any other aspect of this collection of information, including suggestions for reducing this burden, to Washington Headquarters Services, Directorate for Information Operations and Reports, 1215 Jefferson Davis Highway, Suite 1204, Arlington VA 22202-4302. Respondents should be aware that notwithstanding any other provision of law, no person shall be subject to a penalty for failing to comply with a collection of information if it does not display a currently valid OMB control number.

1. REPORT DATE JUN 1991		2. REPORT TYPE N/A		3. DATES COVERED -	
4. TITLE AND SUBTITLE Tests On Photoconductive Semiconductor Switches For Subnanosecond Risetime, Multimega Volt Pulser Applications				5a. CONTRACT NUMBER	
				5b. GRANT NUMBER	
				5c. PROGRAM ELEMENT NUMBER	
6. AUTHOR(S)				5d. PROJECT NUMBER	
				5e. TASK NUMBER	
				5f. WORK UNIT NUMBER	
7. PERFORMING ORGANIZATION NAME(S) AND ADDRESS(ES) Pulse Sciences, Inc. San Leandro, CA 94577				8. PERFORMING ORGANIZATION REPORT NUMBER	
9. SPONSORING/MONITORING AGENCY NAME(S) AND ADDRESS(ES)				10. SPONSOR/MONITOR'S ACRONYM(S)	
				11. SPONSOR/MONITOR'S REPORT NUMBER(S)	
12. DISTRIBUTION/AVAILABILITY STATEMENT Approved for public release, distribution unlimited					
13. SUPPLEMENTARY NOTES See also ADM002371. 2013 IEEE Pulsed Power Conference, Digest of Technical Papers 1976-2013, and Abstracts of the 2013 IEEE International Conference on Plasma Science. Held in San Francisco, CA on 16-21 June 2013. U.S. Government or Federal Purpose Rights License					
14. ABSTRACT Experiments were performed to determine the applicability of photoconductive semiconductor switches (PCSS) for use as output switches in subnanosecond pulse for EMP simulators. Lateral switches made of both Gallium Arsenide and Silicon with 1.5 cm long insulating regions immersed in Fluorinert were tested in a 50 ohm tri-plate transmission line geometry. Mode locked and Qswitched lasers were used to trigger both a gas switched Marx generator which pulse-charged the transmission line in 100-150 ns and to illuminate the PCSS via an optical delay line. Illuminating beam energies and electric field strengths at switchout were varied to determine minimum risetimes and light energies required for triggering. The GaAs switches were operated in the high gain (lockon) mode. Risetimes as fast as 600 ps were observed using a mode locked laser and 700 ps using a Q-switched laser. The minimum light energy required to trigger GaAs was 22 111 and the highest switched fields for both GaAs and Si is about 60 kV/ cm.					
15. SUBJECT TERMS					
16. SECURITY CLASSIFICATION OF:			17. LIMITATION OF ABSTRACT SAR	18. NUMBER OF PAGES 5	19a. NAME OF RESPONSIBLE PERSON
a. REPORT unclassified	b. ABSTRACT unclassified	c. THIS PAGE unclassified			

which decreases as the square of the field. For GaAs there is no strong incentive to increase the charging field to reduce laser energy because the energy needed to initiate lock-on is already very low. However, the risetime of a GaAs PCSS operating in the lock-on mode under fast charge conditions was not known and thus was another subject of this experiment.

The objectives of this experiment were to apply a fast charging pulse to the PCSS of the order of 100-150 ns and to examine the dark breakdown field limits when not triggered by a laser and to examine the switching characteristics when triggered with a laser, including risetime and its relationship to field strength, light energy, and light pulse shape. Switch jitter was also planned to be examined but because of laser problems and laser pulse shape variations, no jitter data was obtained.

TEST CIRCUIT AND HARDWARE

The photoconductive switches were constructed from standard 1-inch-diameter wafers 0.025 inches thick with plated contacts as shown in Figure 1. The GaAs was chrome compensated and had a resistivity of 10 MΩ-cm. Its contacts were prepared by depositing a layer of nickel followed by layers of germanium, gold, nickel and gold. The silicon was high purity zone floated having a resistivity of between 10 and 40 kΩ-cm. Its contacts were prepared by depositing chrome directly on the silicon followed by annealing then depositing a second chrome layer. This was followed by layers of molybdenum and gold. The photoconductive region of the wafers was ~ 2.5 cm wide by 1.5 cm long.

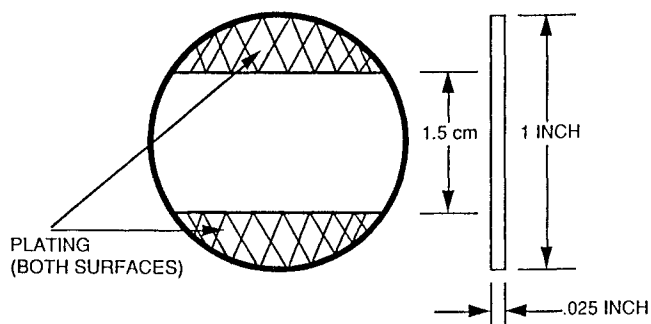

Figure 1. Solid switch wafer.

Two fixtures were used to test the wafers. The first was a wafer holder contained within a pressure vessel and used for the dark breakdown tests. The vessel was pressurized to 25 psig SF₆ to insulate the samples.

During switching tests, a 50-ohm triplate transmission line was used which is shown schematically in Figure 2 with a detailed view of the sample region shown in Figure 3. The transmission line was insulated with plexiglass except in the region of the PCSS sample which used Fluorinert as the insulating medium. Fluorinert was used rather than SF₆ because a pressure vessel to contain the experiment was not available. The sample was mounted at the center of the 6-ft. long line in which one side was pulse charged and subsequently discharged into the other resulting in an output pulse 9 ns wide. The line was terminated with 50-ohms of resistance.

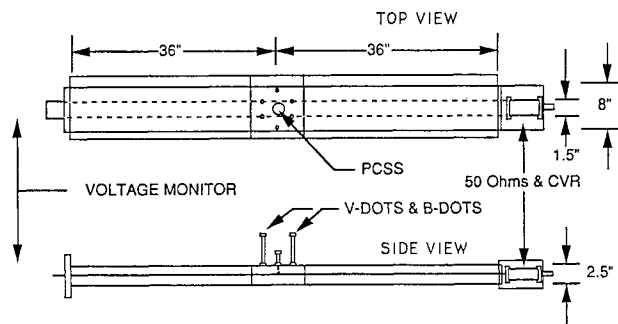

Figure 2. Transmission line test fixture.

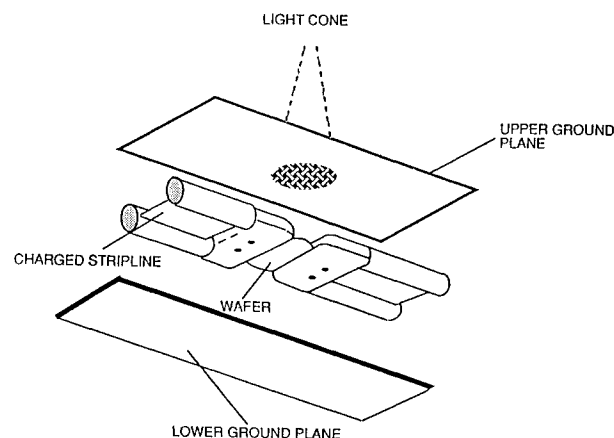

Figure 3. Wafer holder detail.

Two resistive voltage dividers measured the charge voltage applied to the PCSS. One constructed by SNL was situated at the input to the transmission line while the other fabricated by PSI was located at the Marx generator output. The inductance associated with the connection wire differentiated the connection points of the two monitors. A pair of V-dot and B-dot monitors were placed at both the input and output sides of the sample. The V-dot sensor's bandwidth was such that a 50 ps pulse could be observed without distortion. The differential waveform from the output V-dot probe was numerically integrated to provide the actual switched waveform from the PCSS. The CVR located in series with the termination of the transmission line had a resistance of 50 mΩ and was capable of reproducing a waveform with a risetime of less than 0.5 ns.

Instrumentation included two Hewlett Packard 54111D oscilloscopes, one with 1 Gs/sec and a bandwidth of 250 MHz and another with 2 Gs/sec and 500 MHz bandwidth. Two TEK 7104 oscilloscopes were also used with bandwidths of 1 GHz (risetime of 350 ps) and a TEK 7250 oscilloscope was also available with a bandwidth of 6 GHz (risetime of 50 ps). Cabling was 1/2-inch Foamflex.

The Marx generator which was used to pulse the transmission line and PCSS consisted of two stages each capable of being charged to ± 50 kV. Each half stage was constructed of two 1.7 nF "door-knob" capacitors in parallel. The total erected capacity of the Marx was 0.86 nF capable of providing 200 kV into an open circuit. Because of the anticipated large laser jitter, it was necessary to synchronize the Marx discharge waveform with the PCSS wafer illumina-

tion by using the UV (266 nm) output of the laser to trigger the Marx. To do this the first stage switch of the Marx was designed to be laser triggered. This switch had a hole in one of its electrodes and a fused silica window to enable the laser beam to be focussed at the center of the 1 cm gap by a 35 cm focal length lens. The other Marx switch was electrically triggered by the erection transients of the Marx.

In order to prevent the samples from being overstressed by long pulse durations in the event the laser failed to illuminate the wafer or the Marx pre-fired, the PCSS was switched by the laser at or near the peak of the pulse charge which occurred at nominally 100 ns. Also, either a self-breaking crowbar switch was used which was set to break just after peak voltage was reached or the crowbar switch was shorted out and the crowbar resistor shunted the circuit with an L/R risetime sufficiently large to have little effect on the pulse charge but of low enough value to damp late-time oscillation. The test circuit is shown schematically in Figure 4.

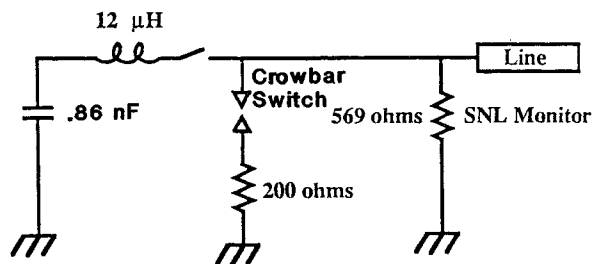

Figure 4. Test circuit.

The lasers available for the experiment included a mode locked Laser Application Nd:YAG and a Spectra Physics Q-switched Quanta Ray DCR-2 Nd:YAG. The mode locked laser produced pulses having a FWHM of about 200 ps like the one shown in Figure 5 but pulse to pulse jitter was on the order of 50-100 ns and operational reliability was poor. The Q-switched laser was operationally more reliable but produced a decidedly non-Gaussian pulse with a FWHM of about 8 ns like the one shown in Figure 6. For both lasers, doubling crystals were used along with Pellin Broca prisms to obtain pure 532 nm light to trigger the wafer and pure 266 nm light to trigger the Marx.

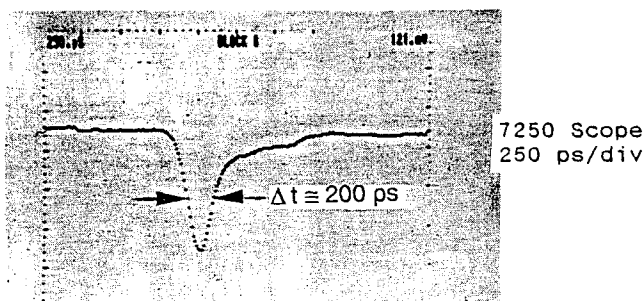

Figure 5. Mode-locked laser pulse.

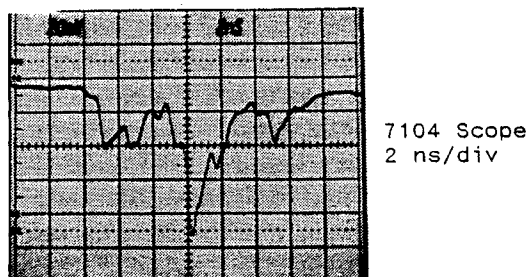

Figure 6. Q-switched laser pulse shape.

DARK BREAKDOWN RESULTS

Only one sample of a GaAs PCSS was able to be tested for dark breakdown. For this test, the wafer was held in the holder and insulated in 25 psig SF₆. With a charging voltage waveform reaching peak in 100 ns, voltages were applied and raised in ~ 10-15 kV steps starting at about 60 kV (40 kV/cm). The voltage was crowbarred at or near peak. Tracking of the sample occurred at 225 kV (150 kV/cm).

The results of this single sample data support the notion that there is a time dependence in the voltage hold-off of the wafer. Previous SNL data showed that in SF₆, a peak field of only 41 and 53 kV/cm was achieved with 2 μsec and for a 30 second hold time, a peak field of 27 kV/cm was reached. Comparable fields of 143 kV/cm had only been achieved under water for a 2 μsec pulse.

Two samples of silicon were tested for dark breakdown in pressurized SF₆. The wafers had a resistivity of only 1 kΩ-cm which was significantly below the intended 8-20 kΩ-cm which may have contributed to their rather low breakdown fields. The first sample tracked at 70 kV (47 kV/cm) and the second failed at 90 kV (60 kV/cm). At SNL, previous tests on silicon with 2 μsec charge times yielded 91 and 89 kV/cm in water and SF₆ respectively. These samples, however, had resistivities in the range of 6-7 kΩ-cm.

LASER TRIGGERED RESULTS

Short pulse laser triggering of the GaAs PCSS was done using the mode locked laser and the test circuit with the crowbar switch shorted. The laser light energy which illuminated the wafer was nominally 200 μJ, and the pulse charge time ranged from 50-80 ns to switchout. The CVR waveform of the output current is similar to those shown in Figure 10. Figure 7 plots the risetimes versus electric fields which ranged from about 30-53 kV/cm across the wafer. The data suggest a possible weak relationship between risetime and electric field, but, in general, the risetimes are about 1 ns.

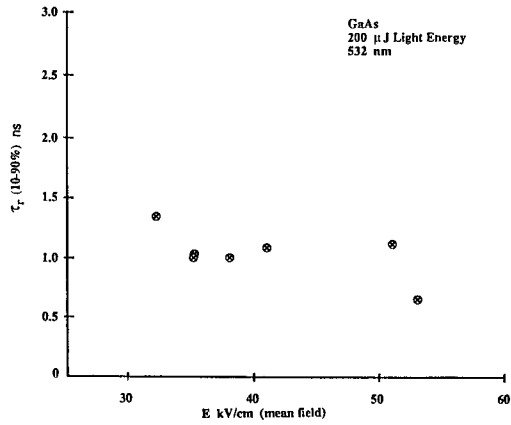

Figure 7. Risetime vs. mean switching field for GaAs for fast pulse mode-locked laser.

Switch risetimes derived from the software interpolated 7250 displays are plotted against the electric fields in Figure 9 where data taken over three separate test days are distinguishable. The optical triggering energy in μJ is shown beside each shot. The risetime decreases from 4 to 5 ns at 20-25 kV/cm switching to as low as 700 ps or less at 50-60 kV/cm. Selected switched current waveforms from the CVR over the range 24-48 kV/cm are shown in detail in Figure 10 which illustrates the risetime decreasing with higher fields. It should be noted that in these tests the parameter of greatest interest was to determine the minimum laser energy required to trigger lock-on at a given field level. No attempt was made to minimize the switch risetime, for instance, as a function of pulse energy at a given field level.

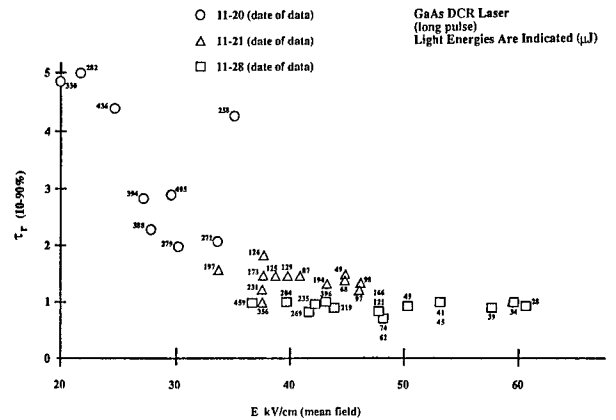

Figure 9. Risetime vs. mean switching electric field for GaAs for slow laser pulse trigger.

A GaAs PCSS was also triggered with the long pulse Q-switched laser using the test circuit. A typical set of waveforms are shown in Figure 8 showing the CVR current, V-dot and integrated V-dot. The CVR waveform shows the initial high discharge current of the transmission line lasting 8 ns followed by the discharge of the remaining Marx energy. The integrated V-dot signal shows the termination mismatch reflection.

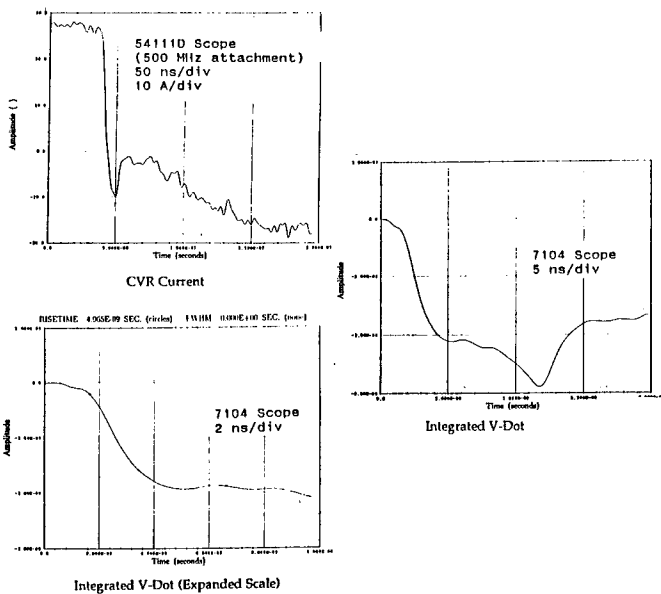

Figure 8. Low field switch of GaAs.

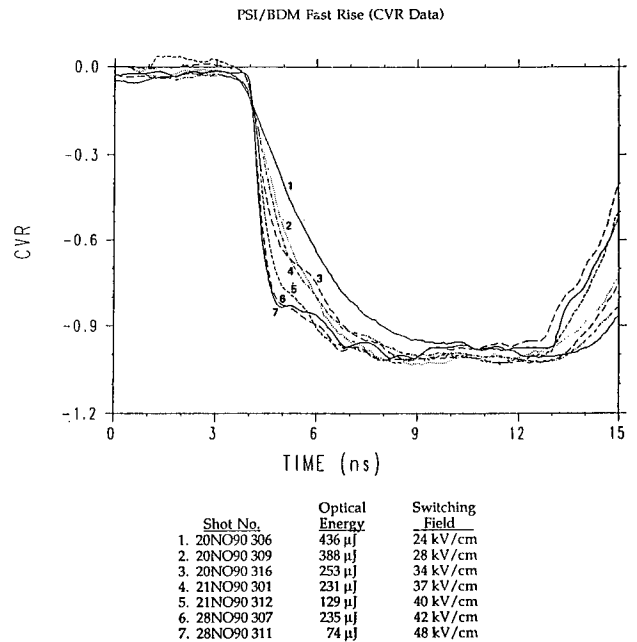

Figure 10. Normalized CVR current waveforms showing switch risetime as a function of electric field across switch.

The optical triggering energy threshold as a function of switching field is shown in Figure 11. The optical energy required to trigger GaAs at 25 kV/cm is about 450 μJ and decreases to about 50 μJ at \sim 40-45 kV/cm. Between 45 and 60 kV/cm, the threshold is reduced to about 22-35 μJ .

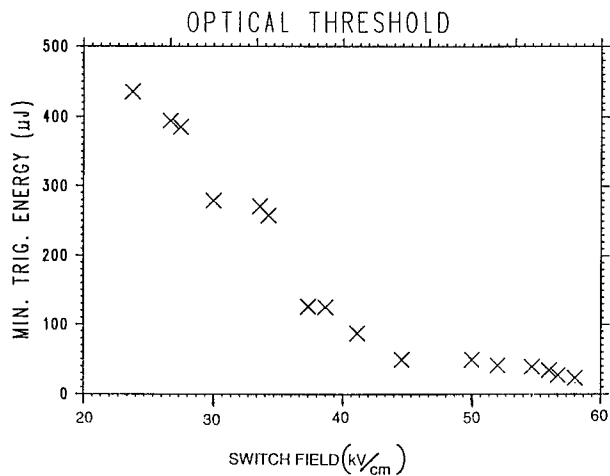

Figure 11. Optical triggering threshold as a function of electric field across the switch.

Silicon wafers were tested employing the circuit of Figure 4 in which the crowbar switch was shorted with a connection. Risetimes of ~ 5 ns were observed with the silicon switch triggered by the Q-switched laser, since sufficient light energy to reduce the resistance of the switch to less than 10% of the circuit impedance occurred within the first 5 ns of the laser pulse. Silicon switching fields ranged from 10 to 65 kV/cm. Tracking occurred in the single sample test at 65.3 kV/cm with fluorinert on the insulating medium.

Fast laser switching of silicon was not performed during this experiment but previous data taken at about 8 kV/cm with 20 mJ of 532 nm light indicate that a 200 ps FWHM laser pulse produces switch risetimes of 200 ps.

CONCLUSIONS

There appears to be an increase in the dark breakdown hold-off of GaAs in SF₆ in going to a faster pulse charge at least based on a single sample. A dark breakdown field of 150 kV/cm was attained for a 100-150 ns charge compared to 50 kV/cm for a 2 μsec charge. Silicon reached only 60 kV/cm compared to 89 kV/cm for a 2 μsec pulse in SF₆ for reasons not known, although wide variation in sample-to-sample hold-off have been observed before at SNL.

For GaAs switches operated in lock-on and under fast pulse charging, triggered by a 200 ps wide laser pulse, risetimes averaging 1 ns, although the fastest was 600 ps, were obtained over an electric field range of ~ 30-60 kV/cm.

For GaAs switched by the Q-switched long pulse laser, risetimes decreased with increases in electric field and reached a low of 700 ps at about 50 kV/cm, although a risetime of 1 ns was closer to the average at the highest fields. The light energy required to trigger the switch decreased with higher electric fields and at 60 kV/cm, only 22 μJ of light triggered the switch into lock-on mode. The highest switched fields under Fluorinert reached 60 kV/cm.

Silicon switching risetimes followed the light input waveform as has been observed by SNL in previous experiments. Risetimes of 5 ns were observed since sufficient laser light energy was deposited in the wafer over this time span to bring the PCSS resistance to less than about 10% of the circuit resistance. The highest switched fields for silicon were 65 kV/cm.

REFERENCES

- [1] BDM Management Services Company, Final Report, *Prototype Distributed Switch Array Checkout*, 306-MI-89-002, October 1989.