

EXPERIMENTAL STUDY OF COMPACT EXPLOSIVE DRIVEN SHOCK WAVE FERROELECTRIC GENERATORS*

S. I. Shkuratov, M. Kristiansen, J. Dickens, A. Neuber

Pulsed Power Laboratory, Department of Electrical and Computer Engineering,
Texas Tech University, Lubbock, TX 79409-3102

L.L. Altgilbers

Advanced Technology Directorate, U.S. Army Space and Missile Defense Command,
P.O. Box 1500, Huntsville, AL 35807

P.T. Tracy

Tracy Physical Sciences Research, Huntsville, AL

Y. Tkach

Institute of Electromagnetic Research, Kharkov, Ukraine

Abstract

The design of explosive driven ferroelectric generators is presented and experimental data are discussed. The active elements are lead zirconium titanate (PZT) disks with diameter $D = 25$ mm and thicknesses $H = 2.5$ mm and $H = 6$ mm and PZT cylinders with $D = 21$ mm and $H = 25$ mm. The high explosive charge was varied from 4.2 g to 30 g. Two different ways to initiate shock waves in the active elements were used: explosively driven flyer plates and direct action of high explosives. The data presented is for the maximum power into a resistive load.

I. INTRODUCTION

The present study was initiated to investigate compact explosive driven pulsed generators based on the depolarization of ferroelectrics by a mechanical shock. The feasibility of these generators was demonstrated in earlier publications [1-3]. The goals of our studies were to compare different generator designs, to obtain data on the effect of ferroelectric active element dimensions on the pulse produced, and to get information about the effect of the load on the generator's energy output.

II. EXPERIMENTAL TECHNIQUE

Schematic diagrams of explosive driven ferroelectric generators (EDFEGs) of two different types are shown in Fig. 1. EDFEGs of both types consist of cylindrical plastic bodies, explosive chambers, active ferroelectric elements, and electrical circuits. The explosive part contains detonator and high explosives (HE) (we used C-4 in all our tests) to initiate the shock wave in the active element. The design with explosive driven flyer plate is shown in Fig. 1(a). The spherical aluminum impactor (flyer plate) is responsible for the initiation of a shock wave in the ferroelectric body. The shape of the spherical

flyer plates was precisely calculated so that a plane shock wave was generated in the ferroelectric active element. The detonation velocity for C-4 is 8.37 km/s. The impactor speed has to reach 3-4 km/s to initiate a shock wave in the active element.

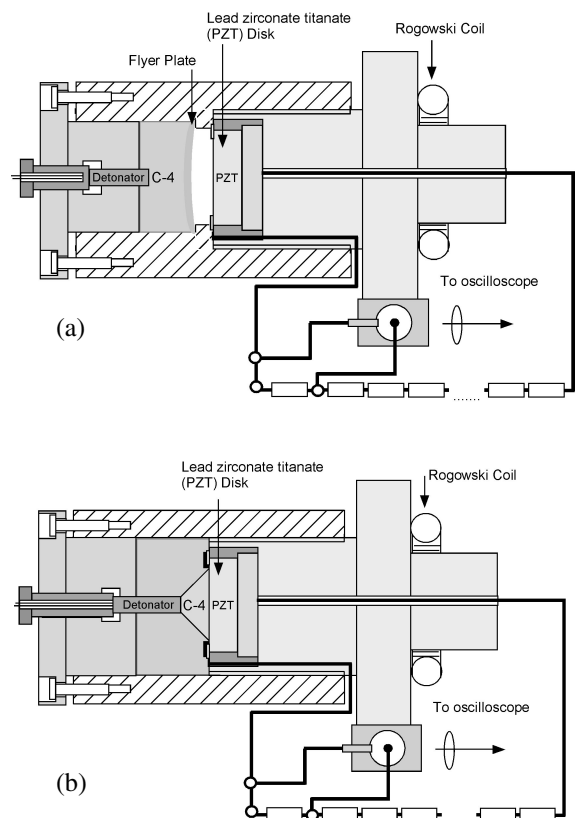

Figure 1. Schematic diagram of EDFEGs with explosive driven flyer plate (a) and with direct action of C-4 on the active element (b).

* This work is funded in part by New World Vista Program in the Air Force Office of Scientific Research (AFOSR)

Report Documentation Page

Form Approved
OMB No. 0704-0188

Public reporting burden for the collection of information is estimated to average 1 hour per response, including the time for reviewing instructions, searching existing data sources, gathering and maintaining the data needed, and completing and reviewing the collection of information. Send comments regarding this burden estimate or any other aspect of this collection of information, including suggestions for reducing this burden, to Washington Headquarters Services, Directorate for Information Operations and Reports, 1215 Jefferson Davis Highway, Suite 1204, Arlington VA 22202-4302. Respondents should be aware that notwithstanding any other provision of law, no person shall be subject to a penalty for failing to comply with a collection of information if it does not display a currently valid OMB control number.

1. REPORT DATE JUN 2001	2. REPORT TYPE N/A	3. DATES COVERED -	
4. TITLE AND SUBTITLE Experimental Study Of Compact Explosive Driven Shock Wave Ferroelectric Generators		5a. CONTRACT NUMBER	
		5b. GRANT NUMBER	
		5c. PROGRAM ELEMENT NUMBER	
6. AUTHOR(S)		5d. PROJECT NUMBER	
		5e. TASK NUMBER	
		5f. WORK UNIT NUMBER	
7. PERFORMING ORGANIZATION NAME(S) AND ADDRESS(ES) Pulsed Power Laboratory, Department of Electrical and Computer Engineering, Texas Tech University, Lubbock, TX 79409-3102		8. PERFORMING ORGANIZATION REPORT NUMBER	
9. SPONSORING/MONITORING AGENCY NAME(S) AND ADDRESS(ES)		10. SPONSOR/MONITOR'S ACRONYM(S)	
		11. SPONSOR/MONITOR'S REPORT NUMBER(S)	
12. DISTRIBUTION/AVAILABILITY STATEMENT Approved for public release, distribution unlimited			
13. SUPPLEMENTARY NOTES See also ADM002371. 2013 IEEE Pulsed Power Conference, Digest of Technical Papers 1976-2013, and Abstracts of the 2013 IEEE International Conference on Plasma Science. IEEE International Pulsed Power Conference (19th). Held in San Francisco, CA on 16-21 June 2013. U.S. Government or Federal Purpose Rights License.			
14. ABSTRACT The design of explosive driven ferroelectric generators is presented and experimental data are discussed. The active elements are lead zirconium titanate (PZT) disks with diameter $D = 25$ mm and thicknesses $H = 2.5$ mm and $H = 6$ mm and PZT cylinders with $D = 21$ mm and $H = 25$ mm. The high explosive charge was varied from 4.2 g to 30 g. Two different ways to initiate shock waves in the active elements were used: explosively driven flyer plates and direct action of high explosives. The data presented is for the maximum power into a resistive load.			
15. SUBJECT TERMS			
16. SECURITY CLASSIFICATION OF:			17. LIMITATION OF ABSTRACT SAR
a. REPORT unclassified	b. ABSTRACT unclassified	c. THIS PAGE unclassified	
			18. NUMBER OF PAGES 4
			19a. NAME OF RESPONSIBLE PERSON

Table 1. Characteristics of PZT EC-64.

Density, kg/m^3	Youngs Modulus, N/m^2	Curie Temperature, Degrees C	Dielectric Constant, ϵ	Piezoelectric Constant d_{33} , m/V or C/N	Piezoelectric Constant g_{33} , $\text{V}\cdot\text{m/N}$ or m^2/C
$7.5 \cdot 10^3$	$7.8 \cdot 10^{10}$	320	1300	$295 \cdot 10^{-12}$	$25 \cdot 10^{-3}$

Another type of FEG without flyer plate is shown in Fig. 1(b). In this case the shock wave in the ferroelectric body is initiated by direct action of the HE on the active element. The mass of HE for this type of FEG was varied from 3 to 5 g. Fig. 2 shows a picture of the FEG in the charged state.

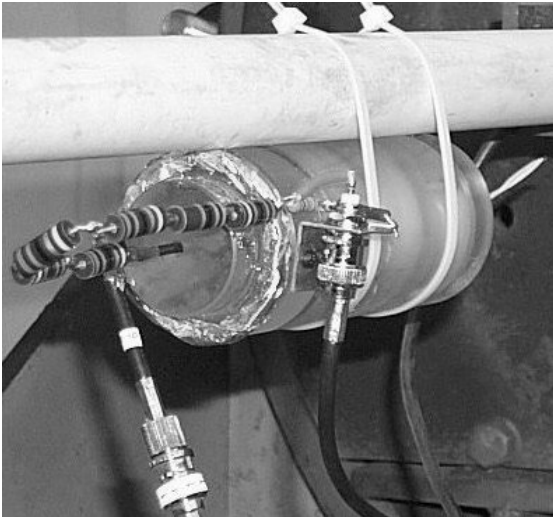
**Figure 2.** Ferroelectric generator in a charged state.

In order to determine the effect of dimensions of the ferroelectric active elements and of the resistance of the load on the energy output, we used the same ferroelectric materials in all the tests performed. It was Lead Zirconate Titanate (PZT) EC-64 (supplied by EDO Corp.). The characteristics of the PZT EC-64 are presented in Table 1. We used PZT disks, 25 mm in diameter and with two different thicknesses: 2.5 mm and 6.5 mm. Also we performed tests with PZT EC-64 cylinders that were 22 mm in diameter and 25 mm in length. The specimens were vacuum coated with silver electrodes. Each specimen was poled to its full remnant polarization value. Photographs of all active elements are presented in Fig. 3.

Each active element was bounded to a copper back plate of 27 mm diameter and 6 mm thickness by a silver-loaded epoxy. The back plate was used to provide mechanical impedance matching for minimizing reflection of the stress wave when it reaches the back face of the specimen. The silver-loaded epoxy was used for electrical contact and to reduce the capacitive reactance of the bond to a negligible value. The specimen and the copper back plate were centered in a cylindrical shell made of plastic. The shell was filled with an epoxy to hold the components in place and to insulate the sides of the specimen against high-voltage breakdown.

Figure 4 presents an equivalent circuit diagram of the generator. We used resistive loads in all the tests performed. All generators were furnished with calibrated Rogowski coils (RC). The sensitivity of the RC was 55 mV/A for the current rise of 10^7 A/s. The voltage signal was picked off from a portion of the load.

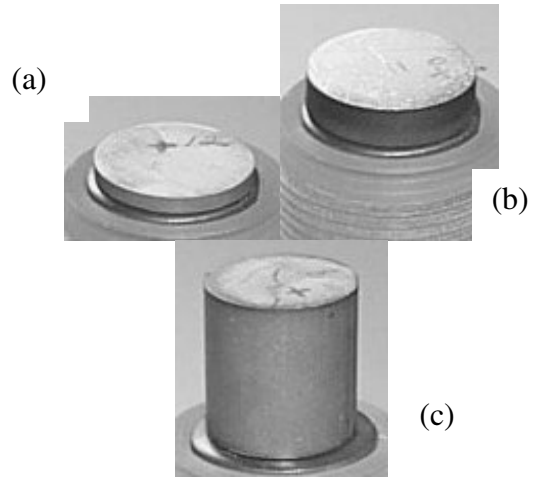
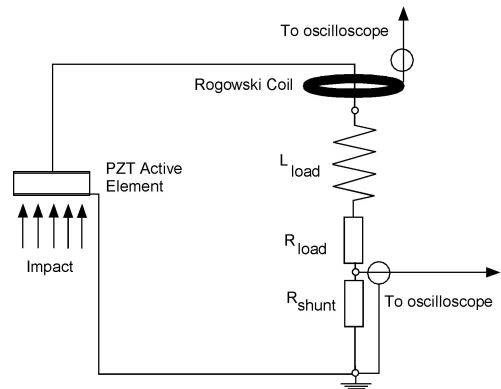
**Figure 3.** Ferroelectric active elements used in the tests. (a) PZT EC-64 disk $D = 25$ mm, $H = 2.5$ mm. (b) EC-64 Disk $D = 25$ mm, $H = 6.5$ mm. (c) EC-64 Cylinder $D = 22$ mm, $H = 25$ mm.**Figure 4.** Equivalent circuit of a ferroelectric generator. L_{load} and R_{load} are the inductance and resistance of the load, respectively. R_{shunt} is the resistance of the probe resistor.

Explosive tests were performed in the explosive facilities of the Pulsed Power Laboratory, Texas Tech University. The explosive tank used in the experiments with small amounts of high explosive (10-100 g) is shown in Fig. 5.

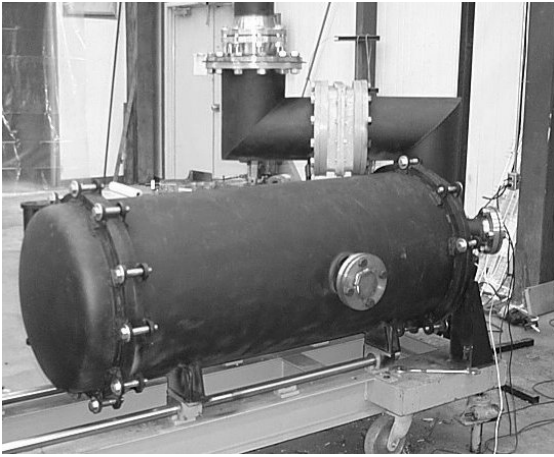

Figure 5. Explosive tank for small (10-100 g) amount of the HE.

III. EXPLOSIVE OPERATION OF EDFEG

The EDFEG after the explosive test is shown in Fig. 6. There are only the remains of the body and parts of the electrical circuit. This is clearly a single-shot system.



Figure 6. Explosive driven ferroelectric generator after the test.

Figure 7 presents the voltage waveforms of the FEG operating with a flyer plate and with direct action of the HE on the ferroelectric body. Active elements in both devices were PZT disks with $D = 25$ mm and $H = 2.5$ mm. The resistance and the inductance of the loads were 40Ω and $0.3 \mu\text{H}$, respectively. The mass of C-4 was 15 g (flyer plate design) and 5.1 g (direct action design).

A shock wave moves along the axis of the disk and as a result of the depolarization of the ferroelectric ceramic, a voltage pulse is generated across the load. The polarity of the pulse produced is determined by the position of the PZT disk. The direction of polarization of the PZT specimen was in the same direction as the shock velocity (the “negative” plate was grounded (Fig. 4)) in both devices shown in Fig. 1.

Comparing the waveforms presented in Fig. 7, differences in the peak voltage amplitude and the widths of pulses produced can be seen. For the direct action

design, the peak amplitude is about 30% less and the pulse is about 1.5 times shorter in comparison with the flyer plate design.

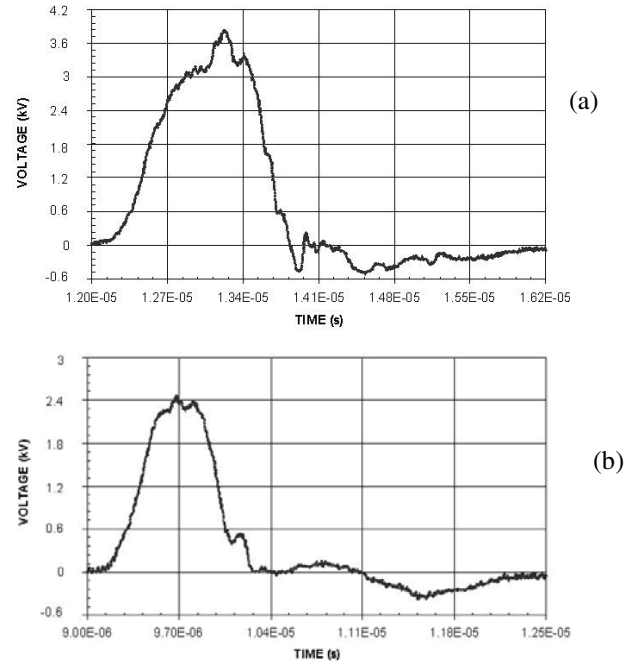

Figure 7. Explosive operation of the EDFEG. Waveforms of the voltage pulses for flyer plate design (a) and direct action design (b). The active elements were poled PZT disks with $D = 25$ mm, $H = 2.5$ mm. The load resistance was 40Ω . The divider coefficient is 1:400.

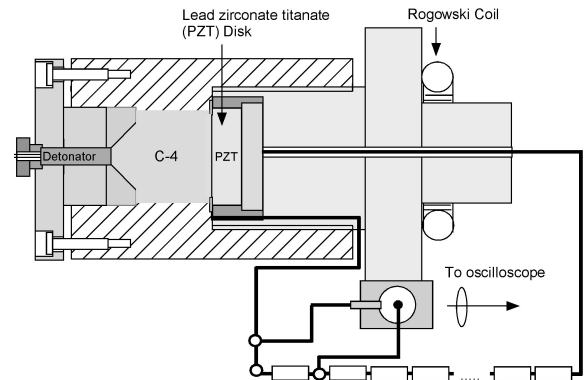

Figure 8. Schematic diagram of FEG with 15 g HE in the direct action design.

We tried different amounts of HE in the direct action design. Figure 8 shows the design of the FEG with a 15 g charge of HE for direct action on the ferroelectric element. In this case the length of the HE charge is longer than the diameter of the PZT disk and we get a planar front of burning HE. The voltage waveform for this test is presented in Fig. 9. The amplitude of generated pulse is close to the one produced in the test with 5.6 g HE charge (Fig. 7(b)). The negative polarity of the pulse produced is determined by the position of the PZT disk. The direction

of the polarization of the PZT specimen was opposite to the shock velocity vector.

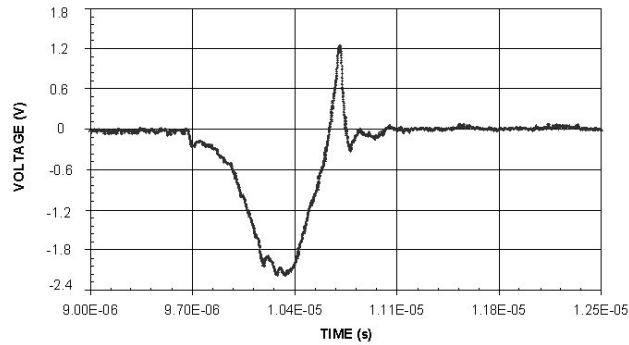

Figure 9. Waveforms of the voltage pulse for the direct action design with 15 g HE (Fig. 7). The active element was PZT disk with $D = 25$ mm, $H = 2.5$ mm. The load resistance was 40Ω . The divider coefficient is 1:400.

Figure 10 presents voltage waveforms for an EDFEG with a flyer plate and with direct action of high explosive (HE) on the ferroelectric body for PZT cylinders with $D = 22$ mm and $H = 25$ mm. The resistance and the inductance of the loads were 40Ω and $0.3 \mu\text{H}$, respectively.

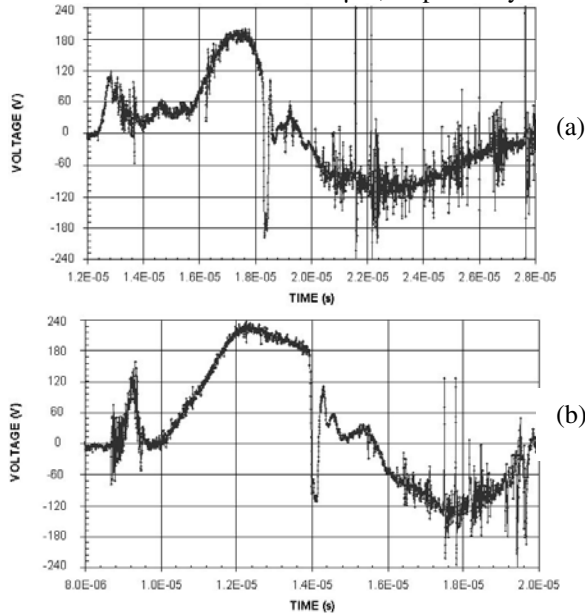

Figure 10. Waveforms of the voltage pulses for flyer plate design (a) and direct action design (b). The active elements were PZT cylinders with $D = 22$ mm, $H = 25$ mm. The load resistance was 40Ω . The divider coefficient is 1:400.

The signals from both devices (Fig. 10) contain high frequency oscillations. Each pulse contains two waves of opposite polarity. The direction of the polarization of the PZT cylinder in the device shown in Fig. 10a was towards the impact plate (the “negative” plate was grounded). The direction of the polarization of PZT cylinder in the device shown in Fig. 10b was in a direction opposite the impact plate (the “positive” plate was grounded). The peak amplitude is significantly lower in comparison with the PZT disks. There are bunches of high frequency

oscillations in both waveforms. The nature of these oscillations is not clear at this time. There are distinctly visible breaks in the middle of the pulses. The same waveforms were obtained for the voltage signals (and breaks in the middle of the pulses) measured for the 400Ω loads.

The output voltage, output power and output energy versus the thickness of the PZT specimens are presented in Figs. 11 and 12. Experiments show that the maximum output voltage, power, and energy are achieved for the thinnest PZT disks.

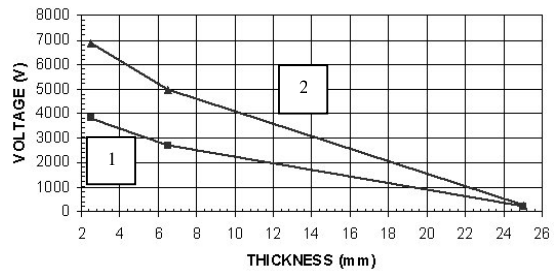

Figure 11. Explosive operation of the EDFEG. The output voltage vs. the thickness of the specimen for 40Ω (curve 1) and 400Ω (curve 2) loads.

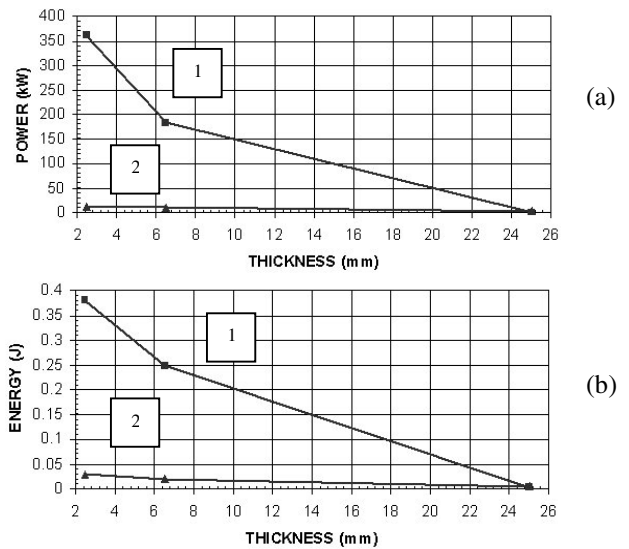

Figure 12. Explosive operation of the EDFEG. The output power (a) and output energy (b) vs the thickness of the specimen for 40Ω (curve 1) and 400Ω (curve 2) loads.

IV. REFERENCES

- [1] F.W. Neilson and G.W. Anderson, Bull. Am. Phys. Soc. Ser II, Vol. 2, 1957, p. 302.
- [2] E.Z. Novitsky, V.D. Sadunov, and G.I. Karpenko, “Behavior of Ferroelectrics in Shock Waves”, Fizika Gorenia I Vzryva, Vol. 14, No. 4, 1978, p.115.
- [3] V.N. Mineev and A.G. Ivanov, “EMF Formed During Sock Compression of Matter”, Sov. Phys. Uspekhi, Vol. 119, No. 11, 1976, p. 75.