

# LARGE RADIUS TRANSPORT CHANNEL STUDIES FOR APPLICATIONS ON SATURN\*

J. W. Schumer, D. D. Hinshelwood, P. F. Ottinger

Plasma Physics Division, Naval Research Laboratory  
Code 6770, 4550 Overlook Avenue SW, Washington, DC 20375

## Abstract

High-current relativistic electron beams (e-beams) produced on the Saturn pulsed power accelerator at Sandia National Laboratory (SNL) can be used to generate high dose bremsstrahlung radiation. Typically, multiple concentric ring diodes on Saturn produce currents of approximately 10 MA at voltages of about 1.8 MV. For some applications, radial convergence of the outer rings to smaller radius is required; one convergence technique studied here is Z-discharge transport (ZDT). To study the beam characteristics and transport efficiencies in ZDT channels at various pressures, 2D fluid/PIC hybrid simulations and bench-top experiments are performed in which  $R_{\text{channel}} \sim L_{\text{channel}}$ . Self-fields and collisional effects were modeled self-consistently using a tenuous medium model. Although simulations of an idealized ZDT channel demonstrated the efficacy of this scheme, bench-top experiments to generate the required discharge currents and plasma density profiles were discouraging. As an alternative, injection and transport of the e-beams through an un-ionized gas and focused by a current carrying cylindrical wire-array were simulated and found to be promising.

## I. INTRODUCTION

Transport and control of high-power (5-10 MA, 1-2 MV) electron beams (e-beams) is important to various bremsstrahlung applications. Transport can be achieved by charge and current-neutralizing the e-beam. Proper selection of background gas, the level of gas pre-ionization, and external fields can achieve beam profile control for specific applications. Although analytic analysis can provide an estimate of performance and allow some optimization of salient features, the non-linear and time-dependent beam-plasma interactions are often modeled numerically.

In this work, numerical simulations were performed to help identify potential schemes for transporting and focusing e-beams produced on Saturn<sup>1</sup> at SNL (1.8 MV, 10 MA, 40 ns FWHM). A unique geometry was required in which all three annular (ring) beams of increasing radii are transported and focused into a region with  $R < 9$  cm, some distance downstream. The beams are injected at  $r = 3.5, 7.5,$  and  $11.5$  cm with a  $\Delta r = 1$  cm, so that only the

outer beam needs to be strongly focused to smaller radius. The middle beam may require some focusing whereas the inner beam should merely remain stable during transport. The goal here was to simulate a series of transport and focusing concepts, providing a “toolbox of transport schemes” for a wide-range of control over the e-beams.

Because of the large beam current (total of 10 MA), self-fields must be shielded for efficient transport. Charge- and current-neutralization can be achieved using a background gas-fill that is sufficient to neutralize yet not so excessive as to collisional stop or scatter the beam. It is also important to prevent adverse beam-to-beam net-current coupling. In the schemes presented here, a nitrogen ( $N_2$ ) gas-fill ranging from 1 to 10 Torr was used and a design length of  $L \sim 15$  cm was chosen.

## II. MODEL

A cartoon of the transport region is shown in Fig. 1. The radius of the channel is 15 cm. A length of 15 - 20 cm is modeled here, although shorter or longer channels could be developed under proper conditions.

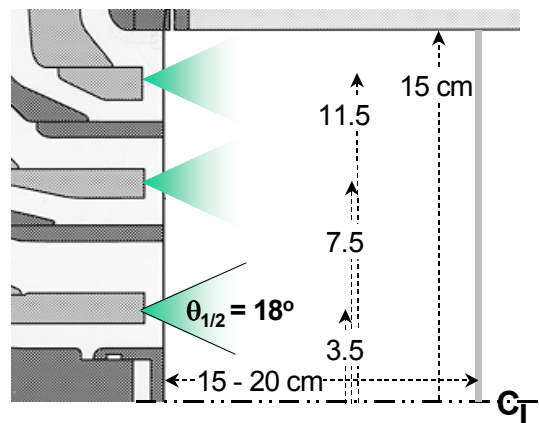

**Figure 1.** Schematic illustrating Saturn anode-cathode structure and e-beam parameters for injection into 15 cm radius transport channel.

In simulations, the injected current was ramped-up linearly from 0 to 10 MA in 10 ns, and then held constant until the end of the 15 ns runtime. The inner, middle, and outer beams were injected between 3 - 4, 7 - 8 and 11 - 12 cm, respectively, with an assumed uniform injected current density. In this three-beam configuration, the inner, middle, and outer beam currents were in the ratio of

\* Work supported by Sandia National Laboratory, US Department of Energy. The authors acknowledge useful conversations and technical directions from Dr. V. J. Harper-Slaboszewicz.

# Report Documentation Page

Form Approved  
OMB No. 0704-0188

Public reporting burden for the collection of information is estimated to average 1 hour per response, including the time for reviewing instructions, searching existing data sources, gathering and maintaining the data needed, and completing and reviewing the collection of information. Send comments regarding this burden estimate or any other aspect of this collection of information, including suggestions for reducing this burden, to Washington Headquarters Services, Directorate for Information Operations and Reports, 1215 Jefferson Davis Highway, Suite 1204, Arlington VA 22202-4302. Respondents should be aware that notwithstanding any other provision of law, no person shall be subject to a penalty for failing to comply with a collection of information if it does not display a currently valid OMB control number.

1. REPORT DATE <b>JUN 2001</b>		2. REPORT TYPE <b>N/A</b>		3. DATES COVERED <b>-</b>	
4. TITLE AND SUBTITLE <b>Large Radius Transport Channel Studies For Applications On Saturn</b>				5a. CONTRACT NUMBER	
				5b. GRANT NUMBER	
				5c. PROGRAM ELEMENT NUMBER	
6. AUTHOR(S)				5d. PROJECT NUMBER	
				5e. TASK NUMBER	
				5f. WORK UNIT NUMBER	
7. PERFORMING ORGANIZATION NAME(S) AND ADDRESS(ES) <b>Plasma Physics Division, Naval Research Laboratory Code 6770, 4550 Overlook Avenue SW, Washington, DC 20375</b>				8. PERFORMING ORGANIZATION REPORT NUMBER	
9. SPONSORING/MONITORING AGENCY NAME(S) AND ADDRESS(ES)				10. SPONSOR/MONITOR'S ACRONYM(S)	
				11. SPONSOR/MONITOR'S REPORT NUMBER(S)	
12. DISTRIBUTION/AVAILABILITY STATEMENT <b>Approved for public release, distribution unlimited</b>					
13. SUPPLEMENTARY NOTES <b>See also ADM002371. 2013 IEEE Pulsed Power Conference, Digest of Technical Papers 1976-2013, and Abstracts of the 2013 IEEE International Conference on Plasma Science. IEEE International Pulsed Power Conference (19th). Held in San Francisco, CA on 16-21 June 2013. U.S. Government or Federal Purpose Rights License., The original document contains color images.</b>					
14. ABSTRACT <b>High-current relativistic electron beams (e-beams) produced on the Saturn pulsed power accelerator at Sandia National Laboratory (SNL) can be used to generate high dose bremsstrahlung radiation. Typically, multiple concentric ring diodes on Saturn produce currents of approximately 10 MA at voltages of about 1.8 MV. For some applications, radial convergence of the outer rings to smaller radius is required; one convergence technique studied here is Z-discharge transport (ZDT). To study the beam characteristics and transport efficiencies in ZDT channels at various pressures, 2D fluid/PIC hybrid simulations and bench-top experiments are performed in which Rchannel ~ Lchannel. Self-fields and collisional effects were modeled self-consistently using a tenuous medium model. Although simulations of an idealized ZDT channel demonstrated the efficacy of this scheme, bench-top experiments to generate the required discharge currents and plasma density profiles were discouraging. As an alternative, injection and transport of the e-beams through an un-ionized gas and focused by a current carrying cylindrical wire-array were simulated and found to be promising.</b>					
15. SUBJECT TERMS					
16. SECURITY CLASSIFICATION OF:			17. LIMITATION OF ABSTRACT <b>SAR</b>	18. NUMBER OF PAGES <b>4</b>	19a. NAME OF RESPONSIBLE PERSON
a. REPORT <b>unclassified</b>	b. ABSTRACT <b>unclassified</b>	c. THIS PAGE <b>unclassified</b>			



1:2:3, all totaling to 10 MA at peak current (i.e. 1.6666, 3.3333, and 5 MA at peak current, respectively). The incoming forward-directed energy of these particles was held fixed at 1.7 MV ( $\gamma_z \sim 4.3$ ) with a thermal component filling a ( $\gamma_r - \gamma_\theta$ ) phase-space cone of  $18^\circ$  half-angle.

To model the physics of breakdown, self-consistent particle transport, and interactions with boundaries, a hybrid particle-in-cell code called LSP<sup>4</sup> (provided by MRC-Albuquerque) was used. LSP is a parallel 3-D electromagnetic code for large-scale electromagnetic plasma simulations. In these simulations, LSP was run in serial using a direct-implicit electromagnetic algorithm and with 2D R-Z cylindrical discretization of  $\Delta r = \Delta z = 0.5$  mm.

A “tenuous” medium model for nitrogen gas was used to apply internally computed energy loss (Moller’s expression) and/or small-angle multiple scattering (Moliere scattering) to electrons. Plasma conductivity is calculated and used to find the plasma response to displacement fields ( $J = \sigma E$ ). The fluid was stationary (no hydrodynamics) and feedback between collisional ionization, the conductivity tensor, and the field solve required use of the direct-implicit EM algorithm.

In all simulations here, the transport channel was filled with a 1 to 10 Torr N<sub>2</sub> gas and pre-ionized up to an initial fractional ionization of 10%. Some preliminary simulations of e-beams injected into a low-pressure gas (0.1 Torr) with significant pre-ionization (10%) became numerically unstable after some time. Although the beam dynamics and transport remained stable, apparently the collisional model did not converge in conjunction with the direct implicit solve when the fractional ionization became too large. For this reason, only pressures of 1 Torr and greater were used to provide an approximate scaling between pressure and transport efficiency or beam stability.

### III. SIMULATION RESULTS

#### A. Injection into a gas, no external fields

To establish the pressure regime applicable for ZDT, baseline simulations were performed to help understand injection into a gas<sup>2</sup> with no applied magnetic fields. Simulations with various levels of pre-ionization (defined by initial ionization fraction  $f = n_e/n_0$ ) and at different pressures of nitrogen were performed.

At 1 Torr, it was found that the beam dynamics could be dramatically altered by changing the initial fractional ionization (pre-ionization). Simulations at 1 Torr with  $f = 10^{-5}$  ( $n_e = 3.536 \times 10^{11} \text{ cm}^{-3}$ ) are illustrated in Fig. 2, showing a rapidly developed instability at  $t = 2.0$  ns. The beam transport became more quiescent at a larger ionization fraction of  $f = 10^{-4}$  ( $n_e = 3.536 \times 10^{12} \text{ cm}^{-3}$ ), shown in Fig 3.

The difference in beam stability between these cases is due to the differences in plasma conductivity during the first few ns. In the  $f = 10^{-5}$  case, the conductivity was  $\sigma <$

$10^{10} \text{ sec}^{-1}$ , permitting magnetic fields to diffuse between each beam ( $L \sim 2$  cm) with a time scale of about  $\tau = 4\pi\sigma(L/c)^2 \sim 0.5$  ns. In this lower conductivity case, the outer beam focused into the middle and inner beams and the total current exceeded the Alfvén limit.

On the other hand, in the  $f = 10^{-4}$  case the initial conductivity was  $\sigma > 10^{11} \text{ sec}^{-1}$ , return currents were isolated between each beam, and the beams exhibited self-pinch transport (SPT). Net current in the high conductivity case at  $t = 0.5$  ns and  $z = 7.5$  cm was about 0.75 kA and magnetic diffusion time between beams was over 5 ns.

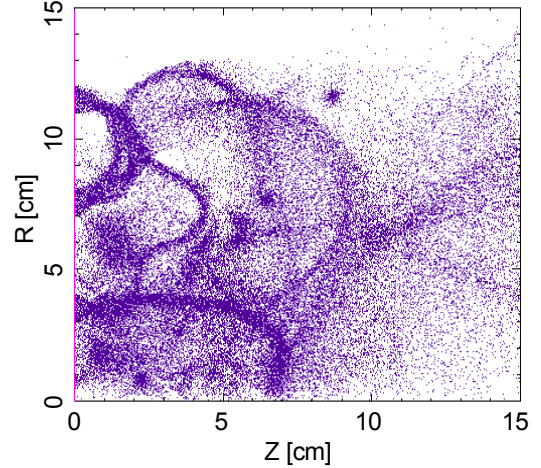

**Figure 2.** E-beams injected into a 1 Torr gas with initial fraction ionization  $f = 10^{-5}$  illustrated highly unstable behavior.

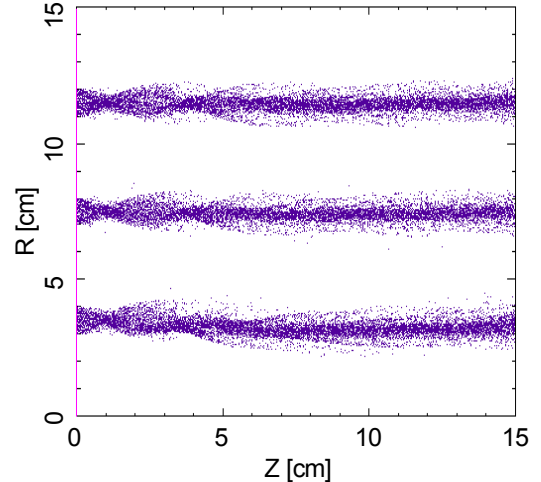

**Figure 3.** E-beams injected into a 1 Torr gas with initial  $f = 10^{-4}$  and no externally applied  $B_\theta$  illustrated quiescent behavior.

Higher pressure baseline tests (10 Torr) with fractional ionizations ranging from  $f = 0 - 10^{-2}$  were stable, although some inter-beam coupling occurred in cases with  $f < 10^{-6}$ . In these simulations, electron-neutral impact ionization in the 10 Torr gas rapidly established sufficient electron density and achieved the conductivity necessary to shield

return currents. In a 10 Torr simulation with  $f = 10^{-6}$  (i.e.  $n_e(0)$  identical to unstable 1 Torr,  $f = 10^{-5}$  case above), the conductivity had exceeded  $6 \times 10^{11} \text{ sec}^{-1}$  level at 0.5 ns. The magnetic diffusion time in this case was about 30 ns, which was greater than the simulation duration.

These baseline simulations demonstrated that at a sufficiently large pressure or initial fractional ionization level, the beams behaved in a pseudo-single-particle fashion that may allow further control (focusing) by applied magnetic fields.

### B. Z-discharge transport channel

A Z-discharge channel is modeled here by imposing an external  $B_\theta(r)$  profile from a uniform axial-discharge current density flowing through a pre-ionized nitrogen plasma ( $n_e = 3.536 \times 10^{15} \text{ cm}^{-3}$ ). A current of 50 kA flows between  $R = 6$  and 12 cm.

Shown in Fig. 4 are electron positions at  $t = 15$  ns from a simulation with 10 Torr nitrogen at  $f = 0.01$  initial fractional ionization. Plasma conductivity is sufficient to locally isolate the beams, thereby allowing the outer e-beam to focus in a “single-particle” fashion in the external discharge fields. In simulations with 1 Torr nitrogen at  $f = 0.1$ , the degree of self-pinching was not as great (more diffuse beams) but focusing was similar.

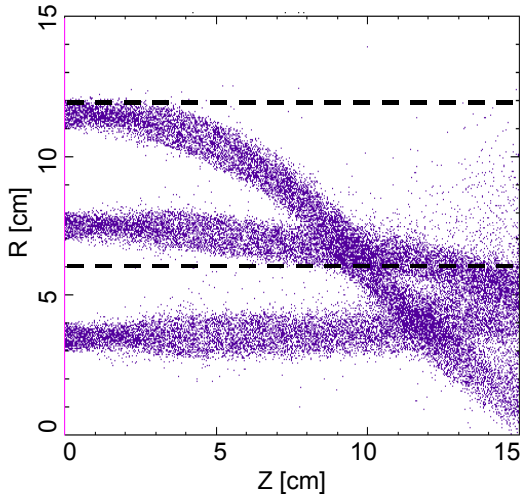

**Figure 4.** Electron positions at  $t = 15$  ns during a simulation of transport in a ZDT channel. The 50 kA annular discharge channel flows uniformly between the dashed lines at 6 and 12 cm through a 10 Torr ( $f = 0.01$ ) nitrogen gas.

Although simulations successfully demonstrated the large-radius ZDT concept, the experimental development of such a channel was difficult. Previous work with small-radius ZDT channels demonstrated that collapsing annular discharges could be produced<sup>3</sup>. However, in recent bench top experiments with 1 Torr of argon, the annular discharge channel formed along the outer radius of the transport channel ( $R \sim 15$ cm), was merely a few cm thick, and did not progress radially inwards. As the pressure was reduced to 250 mTorr, the discharge was

non-uniformly generated near edge-enhanced power-feeds and other protrusions.

Various voltage drivers were applied in an attempt to form a suitable collapsing, large-radius annular discharge, including (a) a 50- $\mu$ F capacitor charged to 3 - 6 kV, (b) a 2- $\mu$ F capacitor charged to 32 kV, and (c) a 200- $\mu$ F capacitor charged to 2 kV. In the end, alternative methods for forming an “annular” current flow were considered.

### C. Cylindrical foils or annular wire-arrays

To avoid the experimental difficulties with fielding a large-radius annular ZDT scheme, a more conservative approach was studied. In this case, e-beams were injected into a gas-filled transport channel and focused by an external magnetic field from a current-carrying cylindrical foil or annular wire-array. The fill pressure was 10 Torr, with low initial fractional ionization of  $f = 10^{-5}$ . A schematic is shown in Fig. 5. A perfectly conducting metallic foil structure runs radially inward from  $R = 15$  cm to 10 cm at  $Z = 5$  cm, axially from  $Z = 5$  to 15 cm at  $R = 10$  cm, then radially outward from  $R = 10$  cm to 15 cm at  $Z = 15$  cm. A  $B_\theta(r)$  magnetic field representative of 25 kA in the foil was initialized inside the dashed line shown in Fig. 5. Fringe fields were not applied.

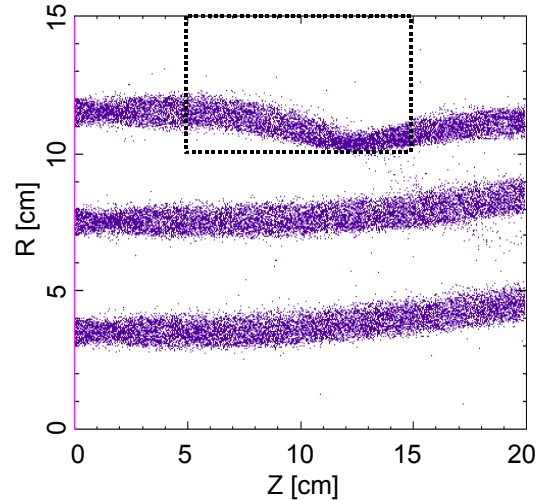

**Figure 5.** E-beams injected into a 10 Torr gas ( $f = 10^{-5}$ ) channel with a long cylindrical focusing foil carrying a current of 25 kA.

In Fig. 5, the outer e-beam appears to reflect from the axial extent of the foil structure. Return currents flow in the metallic boundary more easily than in the plasma channel, thereby producing a defocusing magnetic field near the axial plane and deflecting the outer beam. Also, note that the inner beam is deflected outward slightly by its interaction with the diffused return current of the middle beam. The effect of finite resistivity or circuit inductance on the current in the foil (or wire array) is a topic of future study. Note that, if the conducting boundary condition at the foil is relaxed, the outer beam focuses.

To avoid reflection of the outer beam, the foil structure was redesigned to prevent the outer beam from crossing any axial extent of the foil as shown in Fig. 6. The outer beam is “kicked” inward by the short focus region and self-pinch transported to target. By choosing the foil current to be  $0.5 \beta\gamma$  ( $\text{mc}^3/\text{e}$ ), the focusing radius of the beam equals the injection radius. Assuming the outer beam does not radially focus significantly in the focus region (thin lens approximation), the focus radius  $R_{\text{focus}}$  is determined by the injection point ( $R_{\text{injected}}, Z_{\text{injected}}$ ), the foil length  $L_{\text{foil}}$ , and the focal length  $Z_{\text{focus}}$  to be

$$R_{\text{focus}} = R_{\text{injected}} \sec \theta - (Z_{\text{focus}} - Z_{\text{injected}}) \tan \theta \quad (1)$$

where  $\theta = \sin^{-1}(L_{\text{foil}}/R_{\text{injected}})$ . Using this simple geometric formula to obtain an annular beam with  $R_{\text{focus}} = 9$  cm at  $Z_{\text{focus}} = 15$  cm from the initial outer beam injected at  $R_{\text{injected}} = 11.5$  cm, the focusing length is approximately  $L_{\text{foil}} = 3$  cm.

This concept is illustrated in Fig. 6, showing electron positions at  $t = 15$  ns. In this case, a perfectly conducting metallic foil structure runs radially inward from  $R = 15$  cm to 9 cm at  $Z = 3$  cm, axially from  $Z = 3$  to 6 cm at  $R = 9$  cm, then radially outward from  $R = 9$  cm to 15 cm at  $Z = 6$  cm. A magnetic field representative of  $I_{\text{foil}} = 36$  kA was initialized inside the dashed line shown. In this case, the e-beam does not interact with the axial portion of the foil and, subsequently, an insignificant fraction of return current flows in the foil.

Once the direction of a charge- and current neutralized beam is altered, the beam drifts in a self-pinch manner to the desired focal radius. A multiple foil structure with differing applied currents could focus the three beams to any specified location(s).

#### IV. SUMMARY

In conclusion, several schemes for focusing and transporting e-beam on Saturn have been simulated in 2D using the LSP hybrid particle-fluid code. Injecting the beams into an initially un-ionized or pre-ionized gas requires a fill-pressure of about 10 Torr, generating sufficient conductivity to current-neutralize the beams and insulate them from each other. The need for pre-ionization was demonstrated for optimal control of the beams at low pressure.

Although the ZDT channel focused the beams as required in simulations, experimentally fielding the large-radius ZDT channel proved to be very difficult. To simplify the design concerns, other schemes were investigated using LSP.

Injecting the beams into a gas with a properly selected magnetic field profile yielded the desired beam control with a simpler design. In simulations, beam-foil interactions allowed return currents to generate de-focusing fields. In experiments, it is expected that finite resistivity and inductance in the cylindrical foil structure itself would reduce the levels of de-focusing return

current. Nevertheless, proper design of the focusing structure could avoid beam-foil interactions all together. To this end, a short-focusing foil structure was simulated, and it showed promise.

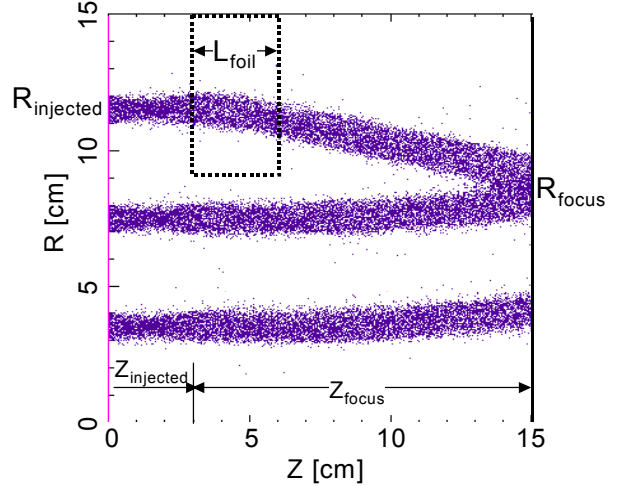

**Figure 6.** E-beams injected into a 10 Torr gas ( $f = 10^{-3}$ ) channel with a short cylindrical focusing foil carrying a current of 36 kA.

Further study is required to assess the impact of non-uniform ionization or different discharge current profiles. The importance of plasma motion has not been considered in this work, and may play a role in lower pressure experiments. Other configurations not considered here, including a cylindrical wire-array (3D analog to the cylindrical foil), will be considered in future studies using LSP in 3D simulations. Of particular importance are effects of the wire array, including complex orbits resulting from azimuthally asymmetric fields and the level of coupling between the beams and the array.

#### V. REFERENCES

- [1] R. B. Spielman, R. J. Dukart, D. L. Hanson, B. A. Hammel, W. W. Hsing, M. K. Matzen, J. L. Porter, “Z-pinch experiments on Saturn at 30 TW,” Proc. 2<sup>nd</sup> Intl. Conf. on Dense Z-pinches, ed. N. R. Pereira, J. Davis, N. Rostoker (AIP, Laguna Beach, CA 1989), pp. 3-16.
- [2] V. J. Harper-Slaboszewicz and W. E. Fowler, “Measurements of the divergence of a 10-MA relativistic electron beam transported in a gas cell,” Laser and Particle Beams, vol. 9, no. 3, 1991, pp. 749-758.
- [3] D.D. Hinshelwood, D.C. Black, G. Cooperstein, P.F. Ottinger, D.V. Rose, and J.W. Schumer, “Z-Discharge Electron Beam Transport for Decade Quad,” 13<sup>th</sup> International Conference on High-Power Particle Beams (Nagaoka, Japan, June 2000), in press.
- [4] D. R. Welch, C. L. Olson, and T. W. L. Sanford, “Simulation of charged-particle beam transport in a gas using a hybrid particle-fluid plasma model,” Phys. Plasma, vol. 1, 1994, pp. 764-773.