

VERY PRECISE SYNCHRONIZATION OF A GROUP OF PSEUDOLITES

Werner R. Lange
Lange-Electronic GmbH
Gernlinden, Germany
T.: +49-8142-2845820
WLange@lange-electronic.de

Abstract

Pseudolites are GNSS transmitters that have a fixed position on the ground and transmit original satellite signals. Very often pseudolites are used around airports and harbors to ease the navigation and increase integrity and availability of satellite navigation systems. Pseudolites are also used in the European “Gate”-Projects. “GATE” is the name of a Galileo test bed where several pseudolites are located around a valley in southeast Bavaria transmitting Galileo signals so that receivers are able to use Galileo signals for testing purpose in “real life” before the satellites are in the sky. Besides this first Gate project, a number of similar pseudolite projects have been established. One of these projects is named “aviation gate” and is located at the research airport of Braunschweig.

This project shall show the use of Galileo signals in aviation – from approach to landing to taxiing. It is extremely important to synchronize the pseudolites as well as possible to minimize the navigation errors.

The system in Braunschweig consists of nine pseudolites and a reference station. The pseudolites are mounted in an inner circle of five systems around the airport and four systems in distances between 30 and 60 km. In the present stage of the project, the inner circle is working, and the outer circle is under construction.

The paper describes the basics and goals of the project and includes the results of the first phase of the project – five free-running GPS receivers are synchronizing five pseudolites. The results look very promising – the five receivers are far better synchronized than anticipated; they are working in a range of about ± 2 ns.

To enhance the accuracy of the timing receivers into the sub-nanosecond range, the receivers have a remote adjustment capability: The reference station continuously measures the range of the pseudolites and is able to adjust the phase of the GPS receivers’ 10 MHz output with a resolution of 25 ps over a WLAN link.

This type of receiver is ideally suited at locations where independent stations require a very high degree of synchronization.

Report Documentation Page

Form Approved
OMB No. 0704-0188

Public reporting burden for the collection of information is estimated to average 1 hour per response, including the time for reviewing instructions, searching existing data sources, gathering and maintaining the data needed, and completing and reviewing the collection of information. Send comments regarding this burden estimate or any other aspect of this collection of information, including suggestions for reducing this burden, to Washington Headquarters Services, Directorate for Information Operations and Reports, 1215 Jefferson Davis Highway, Suite 1204, Arlington VA 22202-4302. Respondents should be aware that notwithstanding any other provision of law, no person shall be subject to a penalty for failing to comply with a collection of information if it does not display a currently valid OMB control number.

1. REPORT DATE NOV 2010	2. REPORT TYPE N/A	3. DATES COVERED -	
4. TITLE AND SUBTITLE Very Precise Synchronization of a Group of Pseudolites		5a. CONTRACT NUMBER	
		5b. GRANT NUMBER	
		5c. PROGRAM ELEMENT NUMBER	
6. AUTHOR(S)		5d. PROJECT NUMBER	
		5e. TASK NUMBER	
		5f. WORK UNIT NUMBER	
7. PERFORMING ORGANIZATION NAME(S) AND ADDRESS(ES) Lange-Electronic GmbH Gernlinden, Germany		8. PERFORMING ORGANIZATION REPORT NUMBER	
9. SPONSORING/MONITORING AGENCY NAME(S) AND ADDRESS(ES)		10. SPONSOR/MONITOR'S ACRONYM(S)	
		11. SPONSOR/MONITOR'S REPORT NUMBER(S)	
12. DISTRIBUTION/AVAILABILITY STATEMENT Approved for public release, distribution unlimited			
13. SUPPLEMENTARY NOTES See also ADA547222. Precise Time and Time Interval (PTTI) Systems and Applications Meeting (42nd Annual) Held in Reston, Virginia on November 15-18, 2010, The original document contains color images.			
14. ABSTRACT Pseudolites are GNSS transmitters that have a fixed position on the ground and transmit original satellite signals. Very often pseudolites are used around airports and harbors to ease the navigation and increase integrity and availability of satellite navigation systems. Pseudolites are also used in the European âGateâ-Projects. âGATEâ is the name of a Galileo test bed where several pseudolites are located around a valley in southeast Bavaria transmitting Galileo signals so that receivers are able to use Galileo signals for testing purpose in âreal lifeâ before the satellites are in the sky. Besides this first Gate project, a number of similar pseudolite projects have been established. One of these projects is named âaviation gateâ and is located at the research airport of Braunschweig.			
15. SUBJECT TERMS			
16. SECURITY CLASSIFICATION OF:			17. LIMITATION OF ABSTRACT
a. REPORT unclassified	b. ABSTRACT unclassified	c. THIS PAGE unclassified	SAR
			18. NUMBER OF PAGES 12
			19a. NAME OF RESPONSIBLE PERSON

THE PROJECT

About 30 years ago, the Airport of Braunschweig was used as small local airport. The most traffic was originated by the fleet of Volkswagen. The scientific flights done by the research organization DLR, the German research organization for aviation and space technology, and the Luftfahrtbundesamt, the people who are the next to appear at airplane accidents after fire brigades and police have done the first jobs.

About 15 years ago, the airport received a new name – Research Airport. That led to an extraordinary growth – several institutes of the Technical University of Braunschweig and a variety of small and medium companies, all related to air and space, settled around the airport – it was in the meantime an extremely important spot of aerospace development in Germany.

In preparation of the European satellite program Galileo, several test beds have been installed. The Institute of Flight Guidance of the TU Braunschweig had the idea to establish an area to test the possibilities of the developing Galileo satellite system. The aim was to taxi, take off, and land under a ground-based Galileo system made up by nine pseudolites. For this purpose, it built two circles of pseudolites, the outer circle of four and the inner circle of five pseudolites.

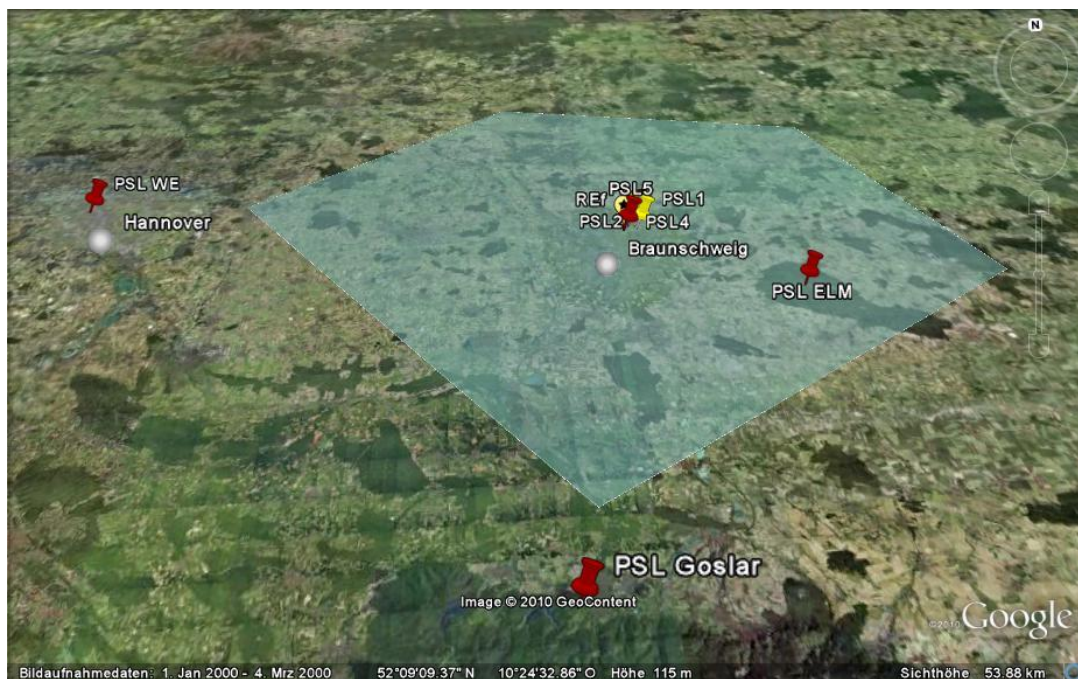

Figure 1. Overview of the greater airport area.



Figure 2. The inner circle.



Figure 3. The view from a pilot's seat.

THE SOLUTION

The inner circle is mainly used during the final approach to the roll- and taxiways and the tarmac. All antennas except one are directed into the inner circle. The transmission angle is 180°. The fifth antenna has a 360° pattern. The outer circle uses three 90° antennas and one with 360°. This antenna is relatively close to the airport and delivers a closer signal during final approach.

The advantage of such a GBAS (Ground-Based Augmentation System) is to test and verify the versatility of the codes, data, signal structure, and, not least, the receivers in a real-life environment. There are disadvantages, too. The positions of the pseudolites are, by all means, flat, so the geometry, i.e. the VDOP is very bad. Then there are near/far effects – the received signal strength varies drastically – while GPS L1 is received at about -120 dBm \pm 2 dBm; the pseudolite signals are between -50 and -125 dBm – far too much for the receivers. Thus, the signals have to be pulsed – another problem, because the design of the coding structure is not designed for this, while, for instance, GPS is. Another disadvantage is that the calculation of the precise position requires the evaluation of the raw data of the receiver.

A major problem is to synchronize the pseudolites in a way that the expectations of accuracy are met – \pm 30 cm of navigation means about \pm 1ns all the time. And the pseudolites are up to 60 km apart. This means the transmitted information's code modulation, the time synchronization, and navigation data have to be selected carefully.

The modulation and time synchronization has to include

- PRN
- time of transmission
- Doppler frequency

thus allowing to measure the precise distance from the receiver to the pseudolites.

A few remarks to the architecture of the system:

- Besides the nine pseudolites, there are two reference receivers
- The total area covers about 5000 km²
- Frequencies used are E1, E5a, and E5, where E1 and E5a/b are produced in separate signal generators
- The navigation message and time synchronization are modified for this application.

The modification of the navigation messages means that they contain no real ephemerides and use the possibility that part of the content of the data can be freely defined.

SYNCHRONIZATION

Each of the pseudolites has its own GPS timing receiver equipped with a double-oven OCXO delivering phase-coherent 10 MHz and 1pps signals to each of the signal generators. The GPS signal shall warrant the long-term stability to within \pm 5ns, for compensation of the resulting offset and the internal drifts of the nine timing receivers, each of which has a second reference oscillator (also DOCXO) that can be remote controlled. The mathematical resolution of this fine adjustment via remote control is 25 ps.

The fine adjust may be done in different ways – a direct control with fast regulation leads to a fast compensation of errors; a deferred, strongly absorbed, and continuous control gives more stable signals and keeps the “real” errors. Both methods have to be optimized during the progress of the tests. The second method is presently used at the system.

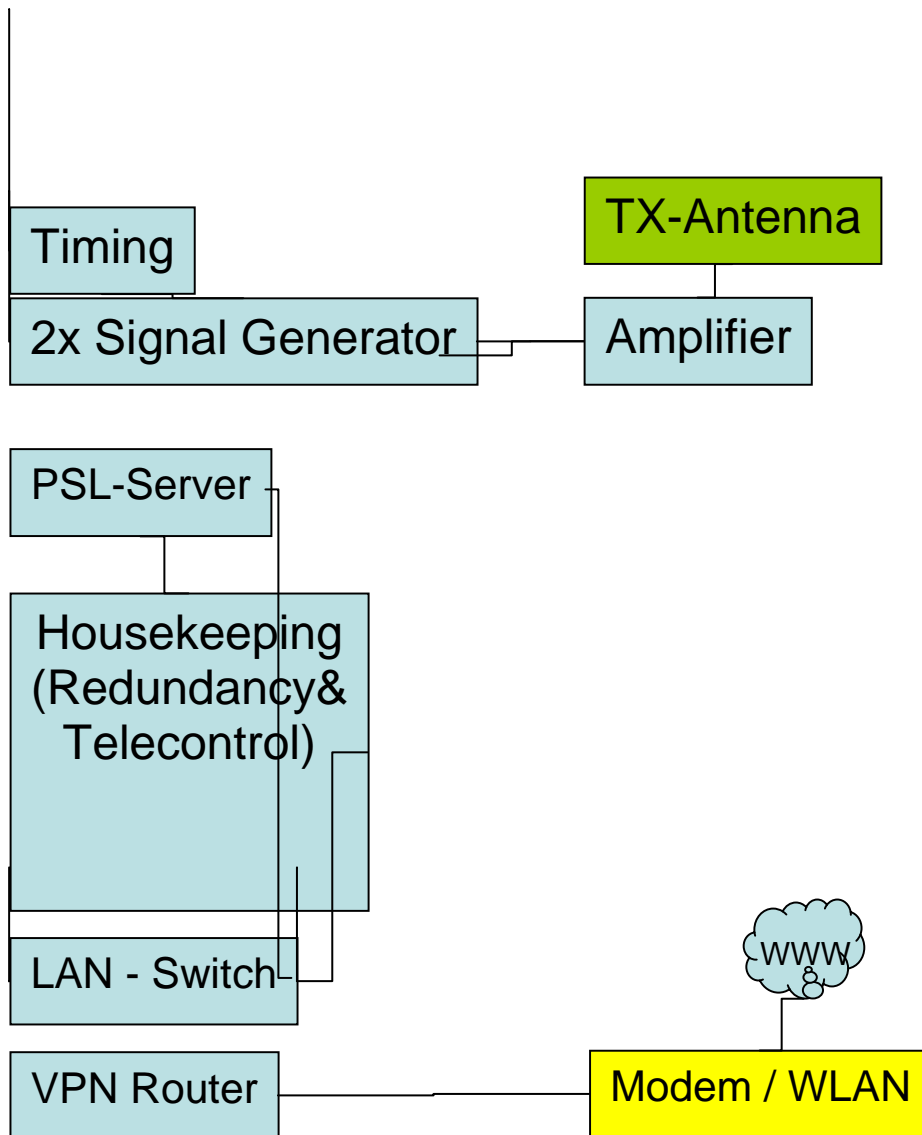

Figure 4. Block diagram of a pseudolite.

Figures 5, 6, and 7 show the difference of the pseudorange of E1 signals of three pseudolites taken from the reference station: uncompensated free running in Figure 5, compensated with a 10 min time constant in Figure 6, and in Figure 7 showing the same results as Figure 6 but with a low pass filter applied.

The red horizontal lines show the limits set by the experiment – ± 1.5 m free running; the green lines in Figure 7 are set to ± 30 cm or $\sim \pm 1$ ns – mission accomplished?

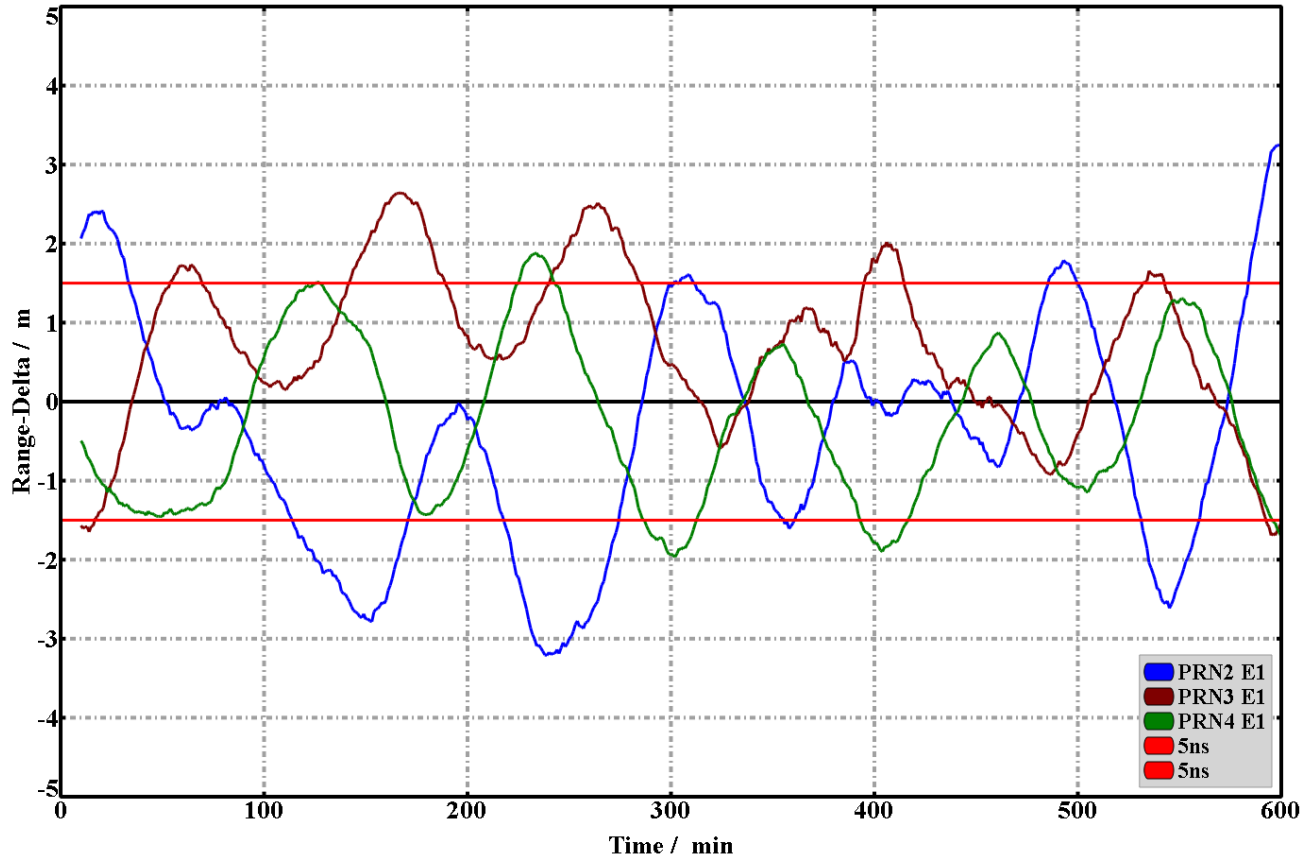

Figure 5. Three of the pseudolites' timing receivers running "uncoordinated" within 10 hrs.

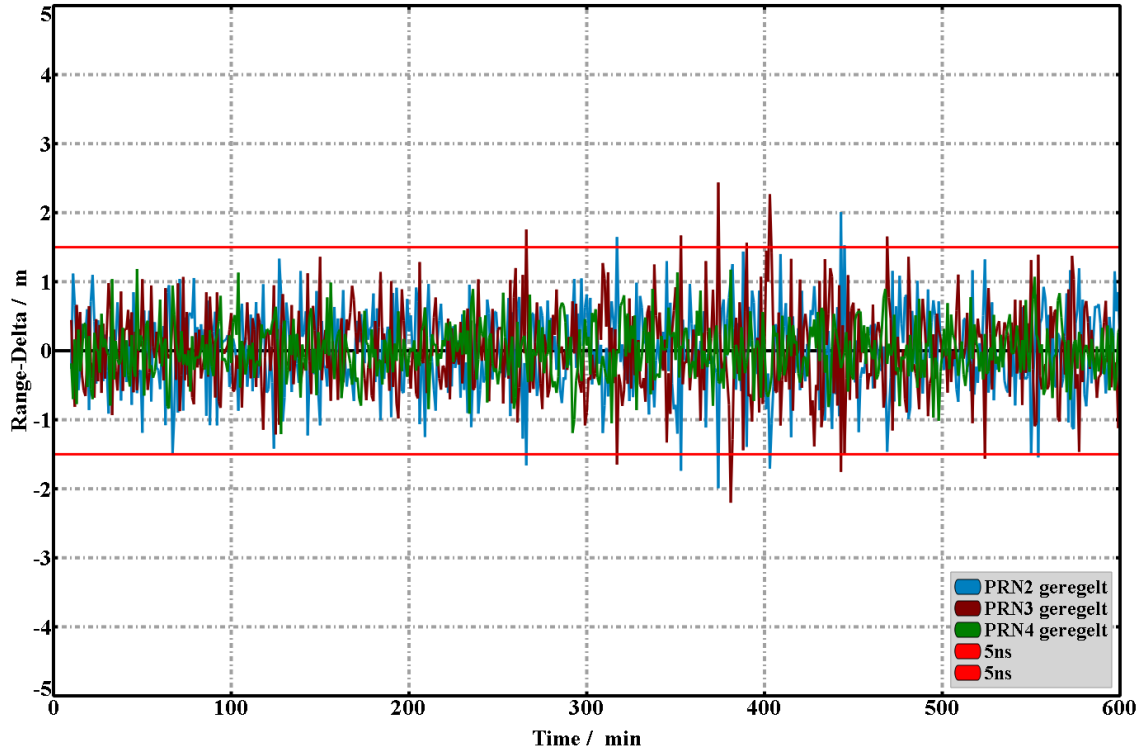

Figure 6. The same receivers with a 10 min control time constant, including noise.

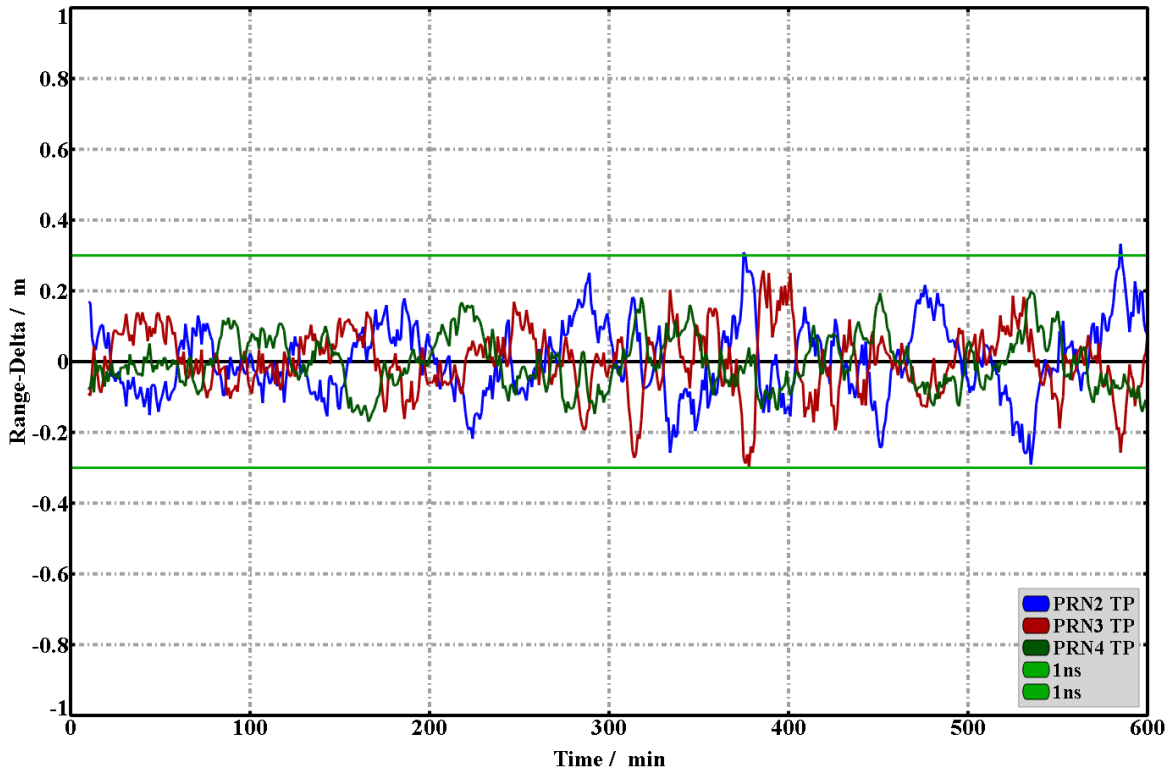

Figure 7. The same receivers with a 10 min control time constant (results low pass filtered).

WHAT COMES NEXT?

Well, we are not really satisfied with the uncompensated drifts seen in Figure 5. We may give the team of TU Braunschweig a next generation receiver with a rubidium atomic clock as primary oscillator – this may make the curves smoother and narrow the extremes, at least as far as they are a result of the behavior of the timing receivers. One has to take into account that these results include a long line of possible errors, starting with the GPS antenna, the timing receiver, the signal generators, the transmission antennas, the transmission path, the receiving Galileo antenna, and the Galileo receiver. Besides, this it may be helpful to equip the reference receiver with a timing receiver, too.

ACKNOWLEDGMENT

Thanks to Dipl.-Ing Benedikt von Wulfen, Institute of Flight Guidance of the Technical University of Braunschweig, for help, tests. and pictures.



Figure 8. The two types of antennas used, the 360° antenna (left) and the 180° Antenna (right).