

5441

LIBRARY USE ONLY

NUWC-NPT Technical Memorandum 962144

Copy 1



Naval Undersea Warfare Center Division
Newport, Rhode Island

**THEORY, DESIGN, AND SUBMARINE APPLICATIONS
FOR A PLASMA ANTENNA**

Theodore R. Anderson
Submarine Electromagnetic Systems Department

30 September 1996

LIBRARY USE ONLY

Approved for public release; distribution is unlimited.

ABSTRACT

This study investigated methods for submarine communications at operational speed and depth. Initial investigations performed under this effort indicated that antennas based on plasmas might be suitable for extremely low frequency transmissions from submarines, thereby offering a capability not currently available to the fleet. Results of a preliminary investigation into the development of the plasma antenna and a description of its overall concept are presented, and a research effort to develop a working prototype is proposed.

ADMINISTRATIVE INFORMATION

Principal investigator for this research was Theodore R. Anderson (Code 3431).

TABLE OF CONTENTS

Section	Page
LIST OF ILLUSTRATIONS	ii
1 INTRODUCTION.....	1
1.1 Objective	1
1.2 Background	1
2 ELECTROMAGNETIC RADIATION PRODUCED BY OSCILLATING PLASMAS.....	3
2.1 Radiation	3
2.2 Reflection	8
2.3 Reception.....	11
3 ANTENNA DESIGN	13
3.1 Plasma Tube	13
3.2 Controller Module	17
3.3 Signal Generator (Transmitter Module).....	17
3.4 Receiver Module	17
3.5 Ionizer Module	17
3.6 Additional Issues	18
4 PROPOSED RESEARCH.....	21
4.1 Phase 1: Plasma Modeling	21
4.2 Phase 2: Plasma Tube Experiments.....	21
4.3 Phase 3: System Development	22
5 SUMMARY	25
REFERENCES.....	27
BIBLIOGRAPHY	29

LIST OF ILLUSTRATIONS

Figure		Page
1	Radiation Pattern of Plasma Column.....	5
2	Antenna Supergain Curve.....	7
3	Wave Reflection at Vacuum/Plasma Interface.....	9
4	NRL Plasma Reflector.....	10
5	Comparison of Reception of ANC Plasma Antenna and 14-Inch Whip Antenna.....	12
6	Equivalent Circuit Model of Plasma Antenna.....	12
7	Typical Plasma Antenna System.....	13
8	Computed Radiation Patterns for Plasma Line Antenna.....	14
9	Coaxial Plasma Tube Design.....	15
10	Plasma Line of 3λ with an Outer Tube Reflectivity of 85 Percent.....	16
11	Planar Plasma Antenna.....	16
12	Conceptual Mounting of Linear Plasma Antenna.....	18

THEORY, DESIGN, AND SUBMARINE APPLICATIONS FOR A PLASMA ANTENNA

1. INTRODUCTION

1.1 OBJECTIVE

This study, which was spurred by the need to develop methods to facilitate submarine communications at operational speed and depth, was initiated to investigate the potential for using plasmas as an antenna. This report represents a conceptual study of a new antenna design that could meet this need; discussions focus on describing the fundamental design of a plasma antenna for use as a submarine-mounted antenna as well as for other potential applications.

Current communication methods include the use of mast-mounted antennas, towed buoys, and towed submersed arrays. Each of these methods has merit; however, the submarine must either breach the surface (mast mount) or slow down (towed arrays) to operate the equipment. At extremely low frequency (ELF), the primary communication frequency band for operational depth, the antennas often become large and unwieldy. The use of plasmas could significantly reduce the physical size of the antenna because the operating frequency of the plasma is a function of density rather than electrical length. The compactness of the antenna design makes its assembly less likely to create a drag on the submarine, allowing the submarine to maintain operating speed while communicating.

1.2 BACKGROUND

Plasma research has made considerable strides over the past 20 to 30 years. Some of the more recent work has investigated methods of measuring plasma characteristics and studying the instabilities associated with plasmas. Plasma antennas are of interest for submarine communications because the plasma frequency is proportional to density rather than electrical/physical length, which allows the antenna to be physically small in comparison with traditional antennas. Because of its size, its installation on a submarine will not cause excessive drag or be unwieldy to deploy. The features of the plasma antenna, coupled with the ability to send (and possibly receive) ELF signals, would enable the submarine to communicate while at operational speed and depth.

Studies characterizing electromagnetic (EM) wave propagation in plasmas have been performed; therefore, the basic concepts have been investigated, albeit for different applications. Efforts have included a corona mode antenna, a propane plasma antenna, and studies of EM

propagation in plasmas. A report on the corona mode antenna describes a project that developed a working prototype of an antenna system that uses the corona discharges of a long wire to radiate ELF signals. Other research has focused on characterizing the EM waves existing in plasmas. The operating frequency and environment are different for this application than those used in previous work: this application involves using the plasma antennas in an undersea environment and for ELF communications.

2. ELECTROMAGNETIC RADIATION PRODUCED BY OSCILLATING PLASMAS

This section describes the physics of the EM radiation from the plasma columns as well as previous methods employed for using a plasma column as a receiver antenna.

2.1 RADIATION

Plasma waves are converted to EM waves by several means including nonlinear interactions (Roussel-Dupré model), oscillations, and scattering.

2.1.1 Roussel-Dupré Plasma Radiation Model

An analysis by Roussel-Dupré and Miller¹ showed that the normalized radiated electric field for a plasma cloud (or column) is given as

$$\begin{aligned} \tilde{E}(s, x, z) = e^{-x^2/D^2} & \left(\int_{-\infty}^z dz' \frac{s}{c^2} \left[e_0 \alpha_0(s, z') e^{i \int_z^{z'} k_z^0 dz''} + e_1 \alpha_1(s, z') e^{i \int_z^{z'} k_z^1 dz''} \right] \right) \\ & + e^{-x^2/D^2} \left(\int_z^{\infty} dz' \frac{s}{c^2} \left[e_0 \alpha_0(s, z') e^{-i z' \int_z^{z'} k_z^0 dz''} + e_1 \alpha_1(s, z') e^{-i \int_z^{z'} k_z^1 dz''} \right] \right), \end{aligned}$$

where

$$\alpha_0 = \frac{s^2 \beta_2^2 + \beta \left(\frac{c^2}{D^2} + \sqrt{\frac{c^4}{D^4} - s^4 \beta_2^2} \right)}{4ik_z^0 \sqrt{\frac{c^4}{D^4} - s^4 \beta_2^2}},$$

$$\alpha_1 = \frac{s^2 \beta_2^2 + \beta \left(\frac{c^2}{D^2} + \sqrt{\frac{c^4}{D^4} - s^4 \beta_2^2} \right)}{4ik_z^1 \sqrt{\frac{c^4}{D^4} - s^4 \beta_2^2}},$$

$$k_x^0 = \left[\left(\frac{1}{D^2} + i \frac{s^2}{c^2} \beta_2 \right) - \sqrt{\frac{1}{D^4} - \frac{s^4}{c^4} \beta_2^2} \right]^{1/2},$$

$$k_x^1 = \left[\left(\frac{1}{D^2} + i \frac{s^2}{c^2} \beta_2 \right) + \sqrt{\frac{1}{D^4} - \frac{s^4}{c^4} \beta_2^2} \right]^{1/2},$$

$$e^0 = \left[\frac{\frac{1}{s^2 \beta_2}}{\frac{c^2}{D^2} + \sqrt{\frac{c^2}{D^4} - s^4 \beta_2^2}} \right],$$

$$e^1 = \left[\frac{\frac{1}{s^2 \beta_2}}{\frac{c^2}{D^2} - \sqrt{\frac{c^2}{D^4} - s^4 \beta_2^2}} \right],$$

$$\beta = \frac{4\pi\sigma_p e^{-z^2/d^2}}{s},$$

$$\beta_2 = \frac{4\pi\sigma_H e^{-z^2/d^2}}{s},$$

$D =$ Length of plasma,

and

$s =$ frequency.

The magnitude of the field is normalized to $V_0 B_0 / c$, where V_0 is the initial plasma velocity, B_0 is the background magnetic field strength, and c is the speed of light. Therefore, the magnitude of the radiated wave is directly influenced by the magnetic field and the plasma velocity.

Roussel-Dupré and Miller's work also showed that the radiated EM wave will have the same frequency as the plasma wave.² Further, in their particular case the plasma cloud or column behaved as a dipole, producing the pattern illustrated in figure 1.

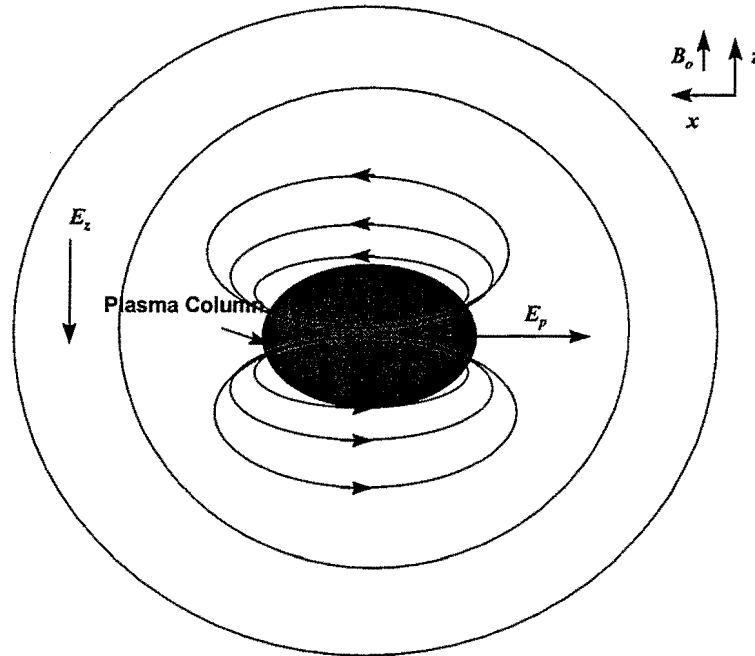

Figure 1. Radiation Pattern of Plasma Column

Numerical analyses performed by Roussel-Dupré and Miller have produced the values for the normalized field. The radiated field typically has a maximum value on the order of $0.5 \cdot V_0 B_0 / c$, suggesting that the radiation efficiency of the plasma column is on the order of 40 to 50 percent.

Measurements and calculations on EM emissions from plasmas have varied significantly. Roussel-Dupré and Miller's work has suggested that emissions were on the order of 25 mV/m at 1.6 km. On the other extreme, measurements on electrostatic discharges (0.5-inch arc, 26 amps) have produced radiated electric fields on the order of 150 V/m at 1.5 meters.

2.1.2 Plasma Oscillations

Other researchers have shown mathematically that plasma oscillations are also responsible for radiating EM fields. Montgomery and Tidman³ have shown that the basic cold plasma equations⁵ are

$$\frac{\partial n}{\partial t} + \frac{\partial}{\partial x} \cdot (nv) = 0 \qquad \frac{\partial v}{\partial t} + v \cdot \frac{\partial}{\partial x} v = -\frac{e}{m} \left(E + \frac{1}{c} v \times B \right),$$

$$\begin{aligned}\frac{\partial}{\partial x} \times E &= -\frac{1}{c} \frac{\partial B}{\partial t} & \frac{\partial}{\partial x} \cdot E &= 4\pi e(N_0 - n), \\ \frac{\partial}{\partial x} \times B &= \frac{1}{c} \frac{\partial E}{\partial t} - \frac{4\pi e}{c} nv & \frac{\partial}{\partial x} \cdot B &= 0,\end{aligned}$$

where N_0 is the ion density, $n(x,t)$ is the density of zero temperature electron gas, and $v(x,t)$ is the velocity. Montgomery and Tidman³ used a perturbation scheme to develop a set of coupled equations, which are solved to determine the radiated field. The solution of the coupled equations is divided into the first- and second-order solutions. The first-order electric field is

$$E = \frac{\partial \phi}{\partial x} \sin(\omega_e t) + A_T \sin(vt - K \cdot x + \alpha).$$

The second term of this equation represents the transverse component of the electric field.

The velocity of the wave is given as

$$v^2 = K^2 c^2 + \omega_e^2,$$

where $K \cdot A_T = 0$. The corresponding magnetic field is given as

$$B = \frac{c}{v} K \times A_T \sin(vt - K \cdot x + \alpha).$$

The source size of the plasma oscillation must also be defined and is given as

$$\phi = \phi_0 (1 + \delta \cdot x) e^{-x^2/L^2},$$

where δ is the deviation from spherical symmetry and L is the thickness of the plasma slab.

The magnetic field at a distance x from the plasma³ is then given as

$$B = \frac{e \kappa^2 \phi_0^2 \sqrt{\pi} L^3}{32 \sqrt{2} m c \omega_e} (\delta \cdot n) (\delta \times n) \frac{\sin(2\omega_e t - \kappa x)}{x} e^{-3\omega_e^2 L^2 / 8c^2},$$

where n is the gas density function of x position and time, e is the electron charge, m is the electron mass, N_0 is the ion density, ϕ is the source size, ω_e is the electron frequency,

$$\omega_e = \sqrt{\left(\frac{4\pi N_0 e^2}{m}\right)}, \text{ and } \kappa \text{ is the wave number } = \frac{\sqrt{3}\omega_e}{c}.$$

Because the electric field is related to the magnetic field via $E = \eta H$, it can be seen that the radiated electric field is also a function of the plasma electron frequency. The frequency of the second-order magnetic field is equal to twice the plasma frequency and is valid when $\omega_e L \leq c$.

Similar equations can be obtained using the plasma ion frequency instead of the electron frequency. The ion frequency is believed to have a more pronounced effect because the mass of an ion is significantly greater than that of an electron.

2.1.3 Scattering

The third source of EM radiation is scattering, which usually occurs at boundaries that are defined by variations in ion density or temperature. As the EM or plasma wave contacts the interface of the discontinuity, a portion of the propagation energy is scattered away from the plasma. Electrons are sufficiently energized to escape the plasma column as a result of radiation excitation. The majority of the research performed to date has used a perturbation technique to derive equations characterizing the field produced by the scattering. The shortcoming of this technique is that it is limited to small signals, so the equations are not valid for the large signals that are of interest in this project.

2.1.4 Supergain

Antennas are considered to have supergain when their gain or directivity is greater than what would be considered normal for a unit of that size.⁵ The normal gain is measured within a sphere large enough to encompass the entire antenna. Figure 2 illustrates the supergain curve as a function of the radius on the enclosing sphere. Antennas are considered to be in the normal region when their gains falls below the curve shown in figure 2.³ Antennas with gains above the curve are considered to be in the supergain region.

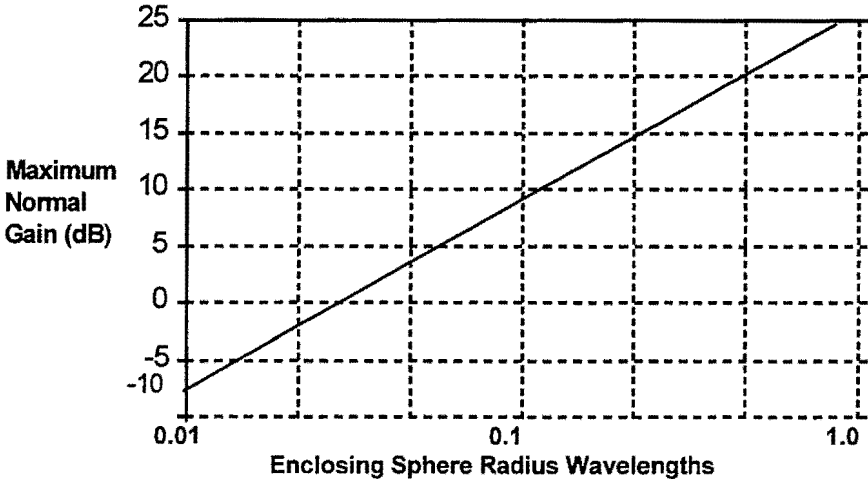

Figure 2. Antenna Supergain Curve

Assume that a linear plasma antenna produces a dipole field as described and has a typical dipole gain of 2.14 dB. Referring to figure 2, a typical wire dipole will have a length of $1/4\lambda$, which, at a 2.14-dB gain, would operate in the normal region. A plasma antenna of equivalent gain and a length that is approximately 40 percent of the $1/4\lambda$ (e.g., $\sim 0.11\lambda$) would actually be operating in the supergain region. This phenomenon is attributed primarily to the reduction in length, which results in a smaller enclosing sphere.

2.2 REFLECTION

Plasmas are capable of passing and reflecting electromagnetic signals. This section describes how EM waves are transmitted and reflected by the plasma antenna. The generic antenna configuration is illustrated in figure 3.

The boundary between the vacuum and the plasma region is depicted at $Z = 0$. The wave components are as follows.⁶

The electric and magnetic field components of the incident wave are given as

$$E_x = E_{x0}e^{+ik_0z} \quad B_y = E_{x0}e^{+ik_0z},$$

where E_{x0} is the amplitude of the incident wave. The components of the reflected wave are given as

$$E'_x = RE_{x0}e^{-ik_0z} \quad B'_y = RE_{x0}e^{-ik_0z},$$

where R is the reflection coefficient. The transmitted wave components are

$$E''_x = TE_{x0}e^{+ik_0z} \quad B''_y = T \frac{E_{x0}k_p c}{\omega} e^{+ik_0z},$$

where T is the transmission coefficient.

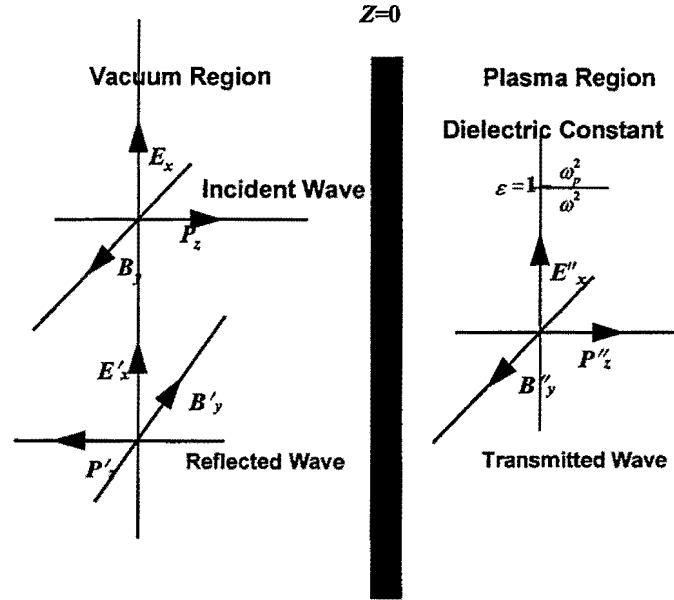

Figure 3. Wave Reflection at Vacuum/Plasma Interface

The relationships between the wave numbers and frequencies in a vacuum and in the plasma are given as

$$k_0^2 c^2 = \omega^2 \text{ (vacuum),}$$

$$k_p^2 c^2 = \omega^2 \left(1 - \frac{\omega_p^2}{\omega^2} \right) \text{ (plasma),}$$

where k_p is the wave number in plasma, k_0 is the wave number in a vacuum, ω_p is the plasma frequency, and ω_0 is the frequency in a vacuum. The coefficients are as follows:⁶

Reflection coefficient:

$$R = \frac{k_0 - k_p}{k_0 + k_p},$$

Transmission coefficient:

$$T = \frac{2k_0}{k_0 + k_p}.$$

Given the relationship between the plasmas and the vacuum, the conditions listed in table 1 are evident. Table 1 shows that for high-frequency waves, there will be perfect transmission. The opposite is true when the incident EM waves are below the plasma frequency. In this case, the incident wave experiences perfect reflection. The reflection/transmission property of plasma is relevant to the design of an antenna, since the phenomenon can be used as a reflector or to reduce the radar cross section of the antenna.

Table 1. Reflection and Transmission Coefficients vs. Frequency

Frequency	R	T	Comment
High ($\omega \gg \omega_p$)	0	1	Perfect transmission
$\omega \geq \omega_p$	$0 < R < 1$	$0 < T < 1$	Partial transmission, partial reflection
$\omega = \omega_p$	1	0	Oscillations
Low ($\omega \ll \omega_p$)	-1	0	Perfect reflection

A system under development by the Naval Research Laboratory (NRL) uses the reflection properties of plasmas to redirect a radar signal.^{7,8} NRL has devised a plasma sheet that is currently mechanically rotated to reflect a high-frequency signal radiated by a driving antenna.⁸ A future system could steer the plasma sheet electronically, which would result in a fast, multifunctional antenna reflector. The NRL device, shown in figure 4, is designed primarily for surface ship applications.

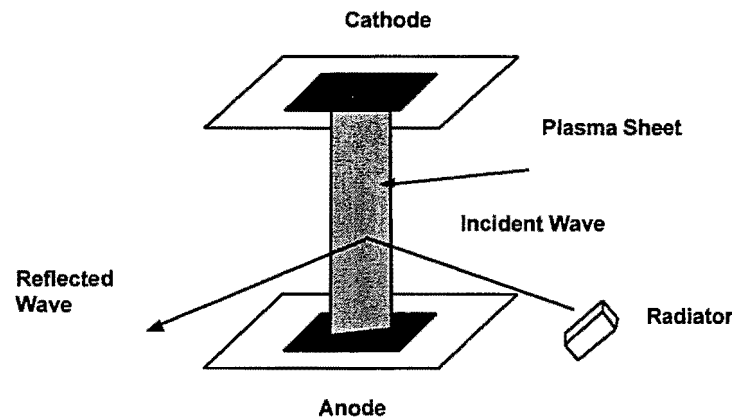

Figure 4. NRL Plasma Reflector

Another potential application of the reflective/transmission properties of the plasma is the reduction of the radar cross section of an antenna. The plasma's transmission properties will reduce the radar cross section as long as the plasma antenna is operating at a frequency below that of search radars. The reduction in the radar cross section might be minimal, because the

mounting structure usually reflects more radar signals than the actual antenna element; however, some reduction should be apparent. For example, consider the case where the plasma antenna is transmitting at a frequency of 30 MHz and is being scanned by a radar operating at 3 GHz. The amount of reflected energy would be on the order of 0.047 percent. This phenomenon is important for submarines only if the antenna is mounted on top of the mast or combined as a conformal antenna on a stealth sail. The reduced cross section is probably more important to the surface ship community, where the antennas tend to be relatively large and can contribute significantly to the cross section of the ship.

2.3 RECEPTION

Research performed by the American Nucleonics Corporation (ANC) in 1965 (sponsored by the Defense Atomic Support Agency) demonstrated the ability of a plasma column to act as a receiving antenna.⁹ The project objective was to develop an antenna to measure the radiated electric field produced by a nuclear explosion. Alternate antenna designs were sought because traditional metal antennas were adversely affected by the ionizing radiation produced by the nuclear event.

The antenna prototype developed by ANC is essentially a propane torch seeded with cesium or barium. The additives provide the flame with a variable conductive component. Because the flame is conductive, EM signals can couple to the plasma. The EM signals are received with a cathode follower pickup wire, which is located within the flame and attracts electrons that in turn give rise to a received voltage. The wire is connected to a traditional spectrum analyzer to measure the induced voltage.

Measurements performed on this design showed that the propane plasma behaved much like a whip antenna. The frequency response of the plasma antenna was essentially linear between 50 kHz and 50 MHz. The researchers suggested that the low-frequency response of the antenna could be improved by increasing the conductivity of the flame (e.g., increasing the cesium concentration).

The sensitivity of the propane plasma antenna was measured and compared to the performance of a 14-inch whip antenna. The results of these measurements are illustrated in figure 5, which shows the received signal (terminal voltage) of the plasma and whip antennas as a function of the generator voltage at the driving antenna. This figure suggests that the plasma antenna is more efficient than the whip. This result, however, could be attributed to the size of the flame, which might have been larger than the 14-inch whip antenna and therefore had a larger capture area (the size of the flame was not specified).

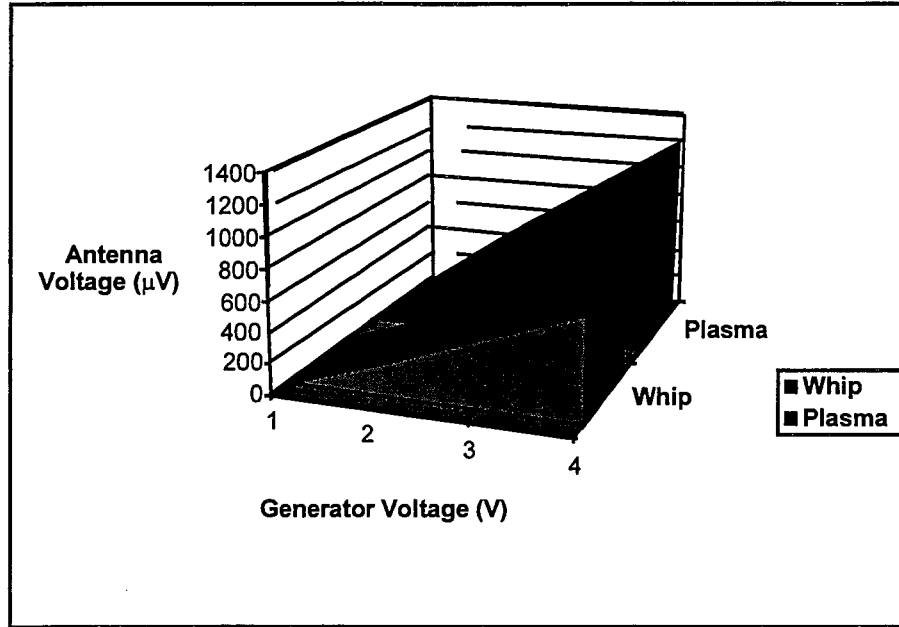

Figure 5. Comparison of Reception of ANC Plasma Antenna and 14-Inch Whip Antenna

A portion of the study was also devoted to developing an equivalent circuit model of the ANC plasma antenna.⁹ The final model, illustrated in figure 6, provides a relationship between the resistance and capacitance of the plasma and the received voltage.

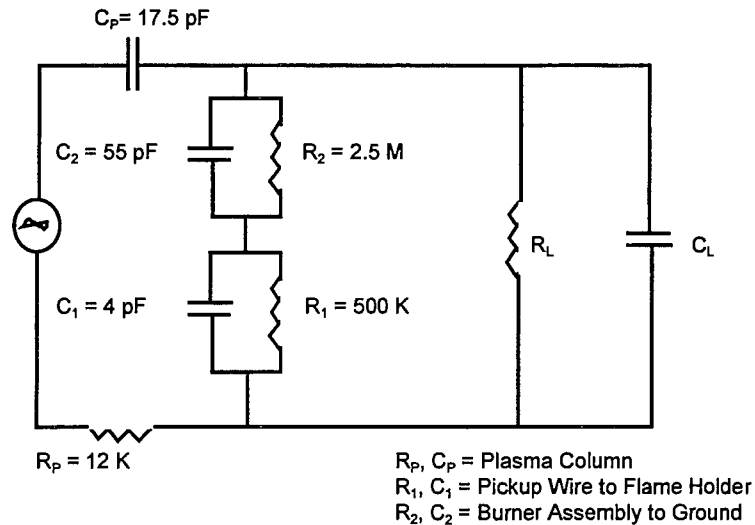

Figure 6. Equivalent Circuit Model of Plasma Antenna

3. ANTENNA DESIGN

Plasma antennas are not intended to replace conventional metal antennas, but to fill specific needs that cannot be met by traditional antennas. Conceptually, the plasma antenna system consists of the antenna (plasma tube), signal generator, ionizer, receiver, and controller, as illustrated in figure 7.

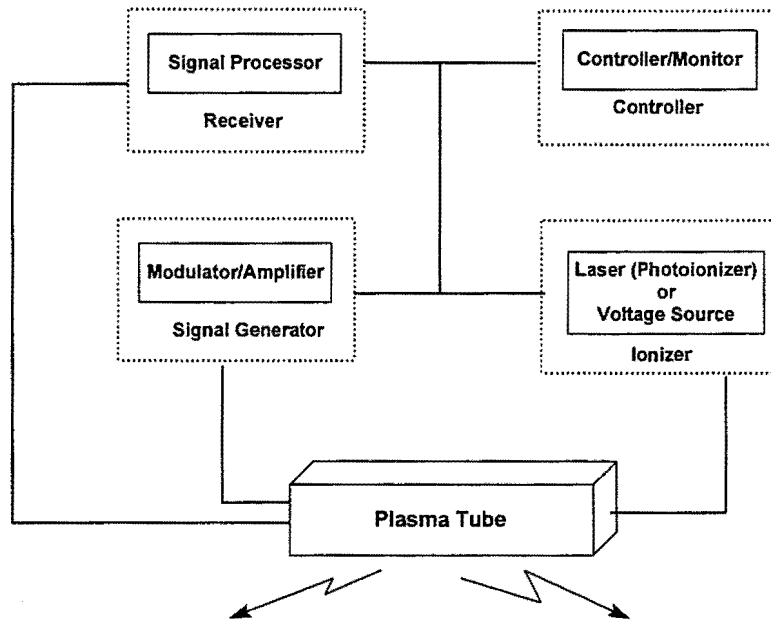

Figure 7. Typical Plasma Antenna System

The antenna is the actual plasma device used to radiate and receive the EM waves. The transmitter includes the hardware used to modulate the plasma with a prescribed signal. The receiver contains the electronics that detect and decode signals contained in the plasma. The initial study focused on the antenna unit, with brief consideration given to the transmitter, ionizer, and receiver subsystems. Much further investigation is necessary.

3.1 PLASMA TUBE

The plasma tube is the key element of the system. Plasma antennas rely on the ionized gas, rather than a wire, to carry the current. The advantage of this technique is that the wave phenomena involved with the ionized gas are influenced by many parameters, making the task of designing a stable system more difficult but providing significantly greater flexibility. Examples of the parameters that influence the wave phenomena in plasmas include, but are not limited to:

- gas type;
- gas pressure;
- electron/ion density;
- current as a function of distance and time;
- tube geometry;
- phased array variations;
- magnetic fields—axial, longitudinal, and normal;
- shaped current distribution; and
- shaped reflectors and semitransparent electrodes.

Given the number of variables, the number of possible combinations and permutations is virtually infinite.

An initial analysis was performed to illustrate how these parameters can influence the radiation pattern of a plasma antenna. A model was implemented to compute radiation patterns for line antennas with varying current distributions. The current distribution can be varied in the plasma by energizing electrodes along the plasma column. The analysis was performed between 6 GHz and 9 GHz (e.g., 2λ and 3λ) on a simple plasma tube. The computed radiation patterns for a 2λ and 3λ plasma line antenna are illustrated in figure 8.

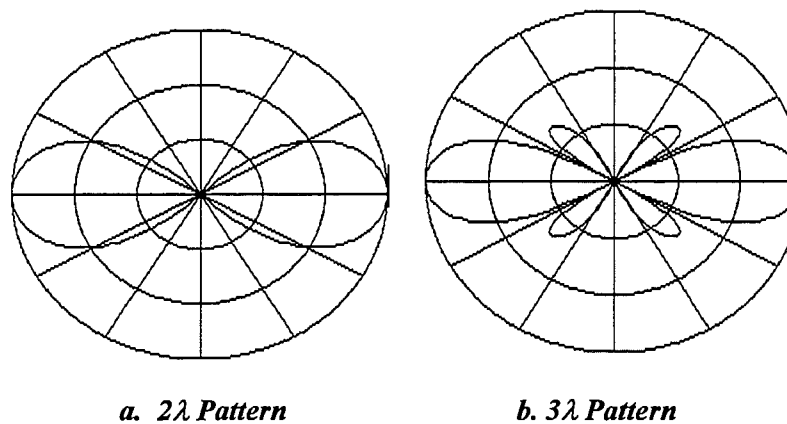

Figure 8. Computed Radiation Patterns for Plasma Line Antenna

Figure 8a illustrates the 2λ pattern. The current distribution is represented by a cosine on a pedestal. The resulting beamwidth of the plasma line is approximately 22° . Figure 8b shows the pattern produced by a 3λ antenna with the same current distribution, a beamwidth of approximately 18° , and distinct sidelobes. The variations noted in these patterns indicate that the beam pattern of the plasma antenna can be changed easily by modifying the plasma frequency.

A coaxial design using voltage-driven electrodes and a planar array is illustrated in figure 9. This design consists of one plasma tube inside another.

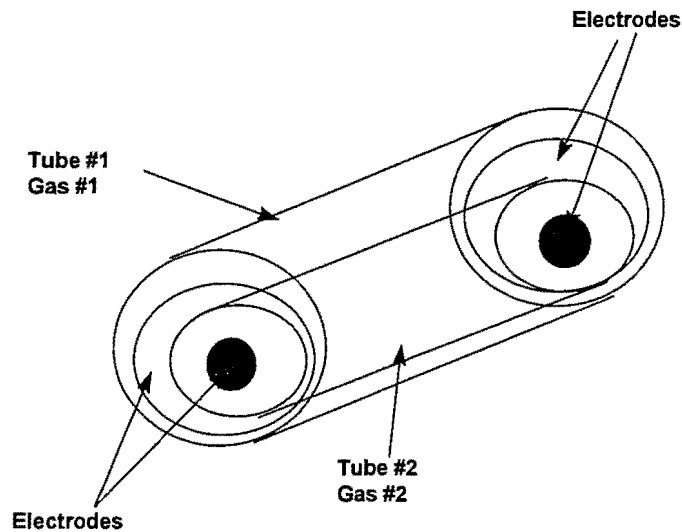

Figure 9. Coaxial Plasma Tube Design

In the coaxial design, the inner tube is used to radiate the intended signal. The outer tube can be used as a dynamically reconfigurable reflector by increasing the density of the plasma so that it becomes greater than the density of the inner tube (refer to section 2.2 for the discussion on reflection).

An analysis was performed to compute the antenna pattern for a 3λ line antenna with a reflector that has an efficiency of 85 percent. This configuration yields a pattern similar to the one shown in figure 10, which illustrates that the reflector significantly reduces the backlobe and concentrates the energy toward the front of the antenna. A fixed reflector can be constructed by adding a conductive coating on one side of the tube.

The second design is a planar array, illustrated in figure 11, consisting of a plasma tube with periodically spaced electrodes. The planar antenna with dispersed electrodes provides additional capabilities to control the pattern. The electrodes change the plasma characteristics to alter the emitted radiation. This approach allows the patterns of the antenna to be altered by user control of nulls located in the plasma waves. By controlling the nulls, the user can define the shape of the radiated beam, thus allowing application of dynamic beam steering to the antenna. The tubes in the planar and coaxial antennas can be constructed using traditional electron/plasma tube construction techniques. The tubes themselves are fabricated from a variety of inert glasses.

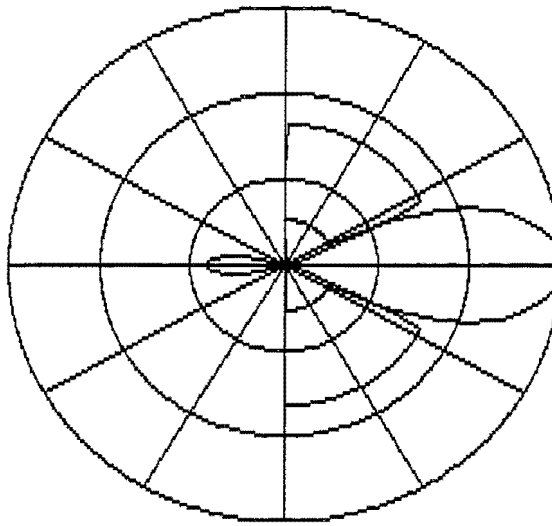

Figure 10. Plasma Line of 3λ with an Outer Tube Reflectivity of 85 Percent

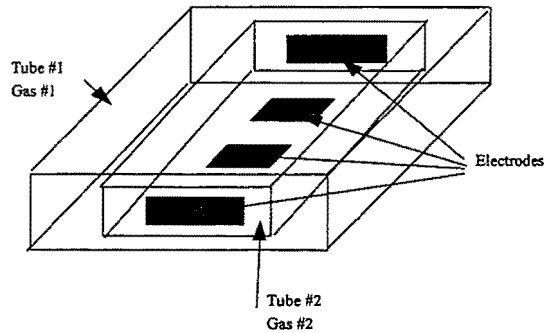

Figure 11. Planar Plasma Antenna

The electrodes function to change the ion density, hence the plasma densities, hence the conductivity at various points. The specific shape of the tube and the location of the electrodes depends on the application. Common materials used for the electrodes are tungsten, tantalum, and oxide-coated metals, all of which permit currents of up to 70 A/cm^2 to be used without showing significant wear.

The length of the plasma tubes, which can vary from a few inches to several feet, is determined by the required radiation pattern and power level. The tubes can be filled with any of the noble gases, including, but not limited to, helium, neon, argon, and xenon.

3.2 CONTROLLER MODULE

The controller is a microprocessor that monitors and controls all the module units and their functions, such as energizing the electrodes and monitoring plasma properties. It uses multiple input/output channels to control the power supplies (ionizer), modulation, and receptor modules.

3.3 SIGNAL GENERATOR (TRANSMITTER MODULE)

The signal generator converts the transmission signals into a format suitable for the plasma antenna. This module will most likely be developed by alternating the magnetic field in the antenna tube. The alternating field can be generated by a series of electromagnets or wire coils. It is anticipated that the magnetic fields will cause deviations in the plasma currents, resulting in modulation. Additional study is required to determine the best method of achieving signal modulation.

3.4 RECEIVER MODULE

The receiver module was not investigated as part of this project; however, previous studies have shown that it is possible to measure signals using a sensing wire or cathode follower within the plasma.⁸ The specific sensing mechanisms employed for the plasma antenna design must be the subject of further research.

3.5 IONIZER MODULE

The ionizer module is responsible for creating and maintaining the ion concentration within the plasma tube, which can be achieved by several methods: electric potential difference, photoionization by laser, radio frequency heating, discharge, and magnetic squeezing under magnetic confinement. The proposed antenna uses energized electrodes to ionize the plasma. The electrode method is the best approach because it provides the greatest flexibility in terms of variability and controllability, and it is the easiest and most efficient method to implement.

The ionizer module for the proposed antenna comprises a series of small power supplies. The number of power supplies can range from one to the number of electrodes, but it is anticipated that a single supply would be sufficient for most applications. The ionizer module also contains a series of attenuator networks that allow each electrode to receive a different voltage level. The attenuator paths and power supply levels are both controlled by the controller module.

In cases where radiating magnetic fields are required, a laser (e.g., CO₂ or neodymium) can be used to drive the plasma. The laser produces Alfvén waves in the plasma that produce a quadrupole magnetic field. The field can be on the order of several megatesla, although the effect is relatively short-lived.

3.6 ADDITIONAL ISSUES

This section describes additional issues associated with the plasma antenna, including mounting, detectability, and fragility.

3.6.1 Antenna Mounting

The size and configuration of the antenna will depend on the gain and radiation patterns of the plasma required to operate successfully. These values were not calculated during the initial study. However, the initial concept is to mount the antenna on the outside of the hull. The preferred mounting technique is to mount the unit, either horizontally or vertically, behind the sail. Other possibilities include mounting the antenna on a mast (smaller version) or deploying the antenna as a towed unit. These attachment points are illustrated in figure 12.

The preferred mounting technique uses a series of mounts to attach the antenna to the hull. For future submarine designs, the antenna can be recessed into the hull structure so that it becomes flush mounted with the deck structure. In either case, the effects of the hull must be studied further to determine the impact of the hull structure on the radiated and received signals.

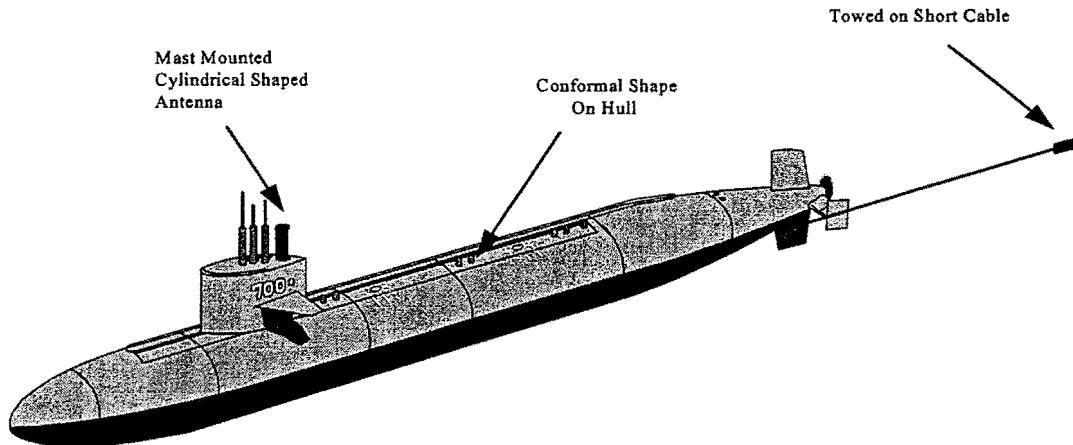

Figure 12. Conceptual Mounting of Linear Plasma Antenna

3.6.2 Detectability

A few issues regarding the inadvertent signature, or emissions, of the plasma antenna require further investigation; they have been acknowledged but not investigated because of time constraints. The issues are important, however, if the submarine is to remain hidden during the use of the plasma antenna.

Ion-Sound Waves. Plasmas can propagate a low-frequency acoustic wave, or ion-sound wave, that arises from perturbations in the charge-separated electric field. These waves are usually present only if the electron temperature is much greater than the ion temperature and the wave frequencies are much higher than the collision frequencies.

Magnetic Field. The plasma antenna can generate a radiated magnetic field, which is normally present only during transmissions. However, the Alfvén wave phenomenon is capable of producing large direct current magnetic fields from the plasma. Further study is required to determine how to control these fields.

3.6.3 Fragility

The design of the antenna tube makes the plasma antenna more fragile than traditional metal antennas. The antenna tube is considered the most fragile component because of its glass construction, but the potential for damage can be reduced by using high-strength glasses, including materials such as Pyrex. Additional investigation into this area is required.

4. PROPOSED RESEARCH

Three phases of effort are proposed, extending from basic phenomenology research to experimentation. Each phase is a vital part of the development of the plasma antenna and provides insight to the design from both theoretical and experimental perspectives.

4.1 PHASE 1: PLASMA MODELING

The objectives of the phase 1 program are to gain a detailed understanding of the basic physical phenomena and to develop analytical models that can characterize the behavior of plasmas as transmitters and receivers of EM radiation. New models are required because the existing radiation equations are based on perturbation theory, which limits the analysis to small signals. The perturbation approach is not generally applicable to the plasma antenna design because the signals are of relatively high magnitudes. The following approach to formulating equations to characterize the plasma antenna is proposed:

1. Perform a time averaging of the Vlasov equations to produce a two-fluid equation model of plasma physics.
2. Generate a one-fluid model of plasma physics by reducing the two-fluid model.
3. Solve the nonlinear one-fluid plasma equations to predict the radiative EM fields from an oscillating plasma.

A computer program will be developed to solve numerically the one-fluid model for use in the antenna design. The results of phase 1 will be a report with a detailed description of the underlying plasma physics and a copy of the computer program.

4.2 PHASE 2: PLASMA TUBE EXPERIMENTS

Phase 2 focuses on additional measurements of existing electron tubes, which will help to characterize the behavior of the plasma tubes in terms of their radiation and reception properties as well as to validate the models developed during the phase 1 study. The measurements to be performed include, but are not limited to, the following:

- *Radiation Pattern.* Measurements will be performed to determine the radiation pattern of the tubes as a function of angle from boresight and frequency. The levels will be expressed in decibels below isotropic.
- *Spectral Noise.* Measurements will determine the spurious emissions from the plasma tubes. The radiated noise from the tubes will be measured from 30 Hz to 1 GHz. The noise will be characterized as a function of tube type, gas, and applied power.

- *Radiation Efficiency.* Measurements will be performed in conjunction with the radiation pattern measurements to compare the radiated field levels as a function of the input power.
- *External Field.* Measurements will characterize the effects of external electric and magnetic fields on the radiation patterns. Electric fields will be created by adding a series of electrodes to the electron tube; magnetic fields will be generated by wrapping the electron tubes in a Helmholtz coil.

The results of these measurements will be summarized in a report. Additional tests will be performed as necessary, based on the findings of phase 1.

4.3 PHASE 3: SYSTEM DEVELOPMENT

The models developed during phases 1 and 2 will be used to formalize the development of the ELF transmit and the supergain antennas. The models will be used to determine the optimum designs, including gas types and density, electrode configurations, power levels, modulation schemes, etc.

The first step in this phase of the process is to establish the design criteria for both the ELF transmit and the supergain antennas. The criteria include, but are not limited to:

- radiation pattern,
- beamwidth,
- maximum power,
- efficiency, and
- noise figure.

Once the design goals have been set, an analysis will be performed to obtain the required performance for the ELF and supergain antennas from a plasma tube.

A series of tradeoff analyses, combined with the results from the measurements performed in phase 2, will then determine the appropriate designs to meet the requirements. The design will be verified through simulation, and prototypes will be constructed.

The tube designs will be sent to a subcontractor, who will fabricate several prototypes of the ELF and supergain antenna tubes for experimentation. The completed antenna tubes will be returned to the Naval Undersea Warfare Center Division, Newport, RI, for evaluation and characterization using the techniques described in phase 2.

Additional design modifications, as deemed necessary, will be made when the initial characterizations have been completed. Modifications will be incorporated into a second generation of the antenna tubes fabricated by the subcontractor.

Prototypes for the other components of the antenna systems, including the modulation drivers, receiver, and controller, will also be developed during this effort using commercial off-the-shelf components. For instance, the controller could consist of a personal computer running standard instrumentation software. Similarly, the modulation drivers could consist of signal generators, controlled by the PC, that apply voltages to the electrodes.

Once the system is configured, additional laboratory experiments will be performed to determine its performance. The results of the experiments and the details of the design will be summarized in a report submitted at the conclusion of the effort.

5. SUMMARY

This report has presented the results of an initial investigation into the development of a plasma antenna, including the basic physics, relevant research, and a proposed design. The plasma antenna appears to be a promising technology that has several possible applications for which traditional antennas might not be suitable. The primary advantage of the plasma antenna is its compact size at low frequencies, since the length of the antenna is not dependent on the EM wavelength.

A number of key points were identified during the initial investigation:

- Plasmas are capable of radiating and receiving EM signals.
- The characteristics of plasma antennas are complex functions of multiple variables including, but not limited to, gas type, gas pressure, physical shape, electrode configuration, applied signals, and external magnetic fields.
- Directivity currently is achieved by use of solid metal antenna arrays and can be achieved by, for example, varying the density of the plasma in a periodic way. The variability of the plasma density gives the plasma antenna distinct advantages over the standard metal antennas.
- Modulation of the signal in plasma antennas can be achieved by varying the plasma density, thus eliminating many of the electronics components used in standard conductive antennas.

Tasks that must be accomplished in further detail include, but are not limited to, the following:

- Continue to develop the overall concept for the plasma submarine antenna.
- Perform a baseline sizing and functionality study to determine the practicality of using a plasma antenna.
- Perform an in-depth study on retrieving signals from the plasma (e.g., methods for using the plasma antenna as a receiver).

REFERENCES

1. R. Roussel-Dupré and R. Miller, "Radiative Properties of a Plasma Moving Across a Magnetic Field, 1. Theoretical Analysis," *Physics of Fluids B*, vol. 5, no. 4, April 1993.
2. R. Roussel-Dupré and R. Miller, "Radiative Properties of a Plasma Moving Across a Magnetic Field, 2. Numerical Results," *Physics of Fluids B*, vol. 5, no. 4, April 1993.
3. D. Montgomery and D. Tidman, *Plasma Kinetic Theory*, McGraw-Hill, New York, 1964.
4. A. Ginsburg, *The Propagation of Electromagnetic Waves in Plasmas*, John Wiley and Sons, New York, 1964.
5. N. Krall, *Principles of Plasma Physics*, McGraw-Hill, New York, 1973.
6. B. Nordwall, "Naval Research Lab Tests Plasma Antenna," *Aviation Week and Space Technology*, 10 June 1996.
7. "Plasma Antenna in a Nuclear Environment," DSA-1733, American Nucleonics Corporation, Glendale, CA, 7 October 1965.
8. M. Van Valkenburg, *Reference Data for Engineers, Radio, Electronics, Computer, and Communications*, 8th Edition, SAMS Publishing, New York, 1993.
9. R. Meger, "Experimental Investigations of the Formation of a Plasma Mirror for High Frequency Microwave Beam Steering," *Physics of Plasmas*, vol. 2, no. 6, 1995.

BIBLIOGRAPHY

- Allis, W., *Wave in Anisotropic Plasmas*, MIT Press, Cambridge, MA, 1963.
- Auld, B., "Signal Processing in a Nonperiodically Time-Varying Magnetoelastic Medium," *Proceedings of the IEEE*, vol. 56, no. 3, 1968.
- Booker, H. G., *Cold Plasma Waves*, Kluwer Academic Publishing, Hingham, MA, 1984.
- Case, K., "Radiation From A Slot Antenna in a Ground Plane Coated With a Moving Plasma Sheath," *IEEE Transactions on Antennas and Propagation*, vol. 19, no. 3, 1971.
- Felson, L., and G. Whitman, "Wave Propagation In Time Varying Media," *IEEE Transactions of Antennas and Propagation*, vol. 18, no. 2, 1970.
- Fischer, B., "Helicon Wave Coupling to a Finite Plasma Column," Institute fur Experimentalphysik II, Ruhr-Universitat Bochum, March 1994.
- Glanz, J., "Electromagnetic Instability and Emission from Counterpropagating Langmuir Waves," *Physics of Fluids B*, vol. 5, no. 4, 1993.
- Hatt, W., "Radiation from an Aperture in a Conducting Plane Coated With a Moving Plasma Layer," Master's Thesis, School of Engineering, Air Force Institute of Technology, Wright Patterson AFB, OH, March 1970.
- Jarem, J., "The Input Impedance of Antenna Characteristics of a Cavity-Backed Plasma-Covered Ground Plane Antenna," *IEEE Transactions on Antennas and Propagation*, vol. 34, no. 2, 1986.
- Kalluri, D., "Effects of Switching a Magnetoplasma Medium on a Traveling Wave: Longitudinal Propagation," *IEEE Transactions on Antennas and Propagation*, vol. 37, no. 12, 1989.
- Kashiwa, T., "Transient Analysis of Magnetized Plasma in Three-Dimensional Space," *IEEE Transactions on Antennas and Propagation*, vol. 36, no. 8, 1988.
- Kojima, T., and T. Higashi, "Electromagnetic Radiation from a Slot Antenna Surrounded by a Moving Magnetoplasma Sheath," *Radio Science*, vol. 8, no. 12, 1973.
- Lewis, J., "Asymptotic Theory of Electromagnetic Wave Propagation in Inhomogeneous Anisotropic Plasma," AFCRL-70-0018, Accession Number 090187, New York University, October 1969.
- Lui, C., "Electromagnetic Oscillating Two Stream Instability of Plasma Waves," MD-TR-80-103, Accession Number 101165, University of Maryland, May 1980.

Tidman, D., and G. Weiss, "Radio Emission by Plasma Oscillations in Nonuniform Plasmas," *Physics of Fluids*, vol. 4, no. 6, 1961.

Tidman, D., and G. Weiss, "Radiation by a Large-Amplitude Plasma Oscillation," *Physics of Fluids*, vol. 5, no. 7, 1962.

Ward, M., "Tubular Antenna in a Plasma Transform Technique," HVD-TR-632, Accession Number 057995, Harvard University, May 1972.

Ward, M., "Cylindrical Antenna in a Hot Plasma a General Analysis Including Longitudinal Wave Excitation Effects," HVD-TR-648, Accession Number 060720, Harvard University, November 1973.

Weil, C., "Radiation Characteristics of Planar Rectangular Apertures Covered by a Layer of Moving Cold Plasma," *IEEE Transactions on Antennas and Propagation*, vol. 37, no. 9, 1989.

DISTRIBUTION LIST

Internal
Codes:

- 10 (R. Nadolink)
- 102 (S. Dickinson)
- 2141 (W. Keith)
- 34 (P.M. Trask)
- 34A (J.F. Boucher)
- 341 (G.M. Exley)
- 3412 (R.C. Olesen)
- 3413 (J. Casey)
- 3414 (S.C. Stefanowicz)
- 3421 (W.P. Huntley)
- 3422 (H. Anderson, G.E. Holmberg)
- 343 (D.S. Dixon)
- 3431 (T. Anderson (20), C.F. Derewiany)
- 3432 (B.C. Eccles)
- 3433 (T.R. Floyd)
- 3491 (R.J. Aiksnoras)
- 3492 (P.S. Sheldick)
- 3493 (C.E. McMillan)
- 3495 (J. Perry)
- 3496 (F.C. Allard)
- 3497 (C.M. Floyd)
- 3498 (C. Amidon)
- 5441 (2)

Total: 46