

29 OCT 1986

LIBRARY USE ONLY

86-2065 -

29 OCT 1986

TM No. 86-2065

cy #1

NAVAL UNDERWATER SYSTEMS CENTER
NEWPORT LABORATORY
NEWPORT, RHODE ISLAND 02841



Technical Memorandum

EVALUATION OF IBM PC-BASED AN/USM-465
WORKSTATION INTEGRATION PACKAGE

Date: 22 September 1986

Prepared by: Michael S. Kalisz
Michael S. Kalisz
Operational Systems Division
Combat Control Systems Department

Approved for public release; distribution is unlimited.

UNCLASSIFIED
NAVAL UNDERWATER SYSTEMS CENTER
NEWPORT LABORATORY
NEWPORT, RHODE ISLAND 02841
EXCLUDED FROM AUTOMATIC DOWNGRADING AND
DECLASSIFICATION

LIBRARY USE ONLY

Report Documentation Page

Form Approved
OMB No. 0704-0188

Public reporting burden for the collection of information is estimated to average 1 hour per response, including the time for reviewing instructions, searching existing data sources, gathering and maintaining the data needed, and completing and reviewing the collection of information. Send comments regarding this burden estimate or any other aspect of this collection of information, including suggestions for reducing this burden, to Washington Headquarters Services, Directorate for Information Operations and Reports, 1215 Jefferson Davis Highway, Suite 1204, Arlington VA 22202-4302. Respondents should be aware that notwithstanding any other provision of law, no person shall be subject to a penalty for failing to comply with a collection of information if it does not display a currently valid OMB control number.

1. REPORT DATE 22 SEP 1986	2. REPORT TYPE Technical Memo	3. DATES COVERED 22-09-1986 to 22-09-1986	
4. TITLE AND SUBTITLE Evaluation of IBM PC-based AN/USM-465 Workstation Integration Package		5a. CONTRACT NUMBER	
		5b. GRANT NUMBER	
		5c. PROGRAM ELEMENT NUMBER	
6. AUTHOR(S) Michael Kalisz		5d. PROJECT NUMBER	
		5e. TASK NUMBER	
		5f. WORK UNIT NUMBER	
7. PERFORMING ORGANIZATION NAME(S) AND ADDRESS(ES) Naval Underwater Systems Center, Newport Laboratory, Newport, RI, 02841-5047		8. PERFORMING ORGANIZATION REPORT NUMBER TM 862065	
9. SPONSORING/MONITORING AGENCY NAME(S) AND ADDRESS(ES) Naval Sea Systems Command, Washington, DC, 20362		10. SPONSOR/MONITOR'S ACRONYM(S) SEA 06C12	
		11. SPONSOR/MONITOR'S REPORT NUMBER(S)	
12. DISTRIBUTION/AVAILABILITY STATEMENT Approved for public release; distribution unlimited			
13. SUPPLEMENTARY NOTES NUWC2015			
14. ABSTRACT The Workstation Integration Package (WIP) proved to be a useful tool in the development of GO/NOGO Test Programs for the AN/USM-465. The WIP provided both cost and time savings. Aside from one problem in the TRANSLT routine, the WIP functioned very well. Use of the WIP provided uniform and consistently high-quality test programs.			
15. SUBJECT TERMS Workstation integration package; WIP; GO/NOGO Test Programs; AN/USM-465; Micro computer; Navy standard test program set			
16. SECURITY CLASSIFICATION OF:			17. LIMITATION OF ABSTRACT Same as Report (SAR)
a. REPORT unclassified	b. ABSTRACT unclassified	c. THIS PAGE unclassified	
			18. NUMBER OF PAGES 38
			19a. NAME OF RESPONSIBLE PERSON

REPORT DOCUMENTATION PAGE

86-2065

1a REPORT SECURITY CLASSIFICATION UNCLASSIFIED			1b RESTRICTIVE MARKINGS <i>of 1</i>			
2a SECURITY CLASSIFICATION AUTHORITY			3 DISTRIBUTION/AVAILABILITY OF REPORT Approved for public release; distribution is unlimited.			
2b DECLASSIFICATION/DOWNGRADING SCHEDULE						
4 PERFORMING ORGANIZATION REPORT NUMBER(S) TM No. 86-2065			5 MONITORING ORGANIZATION REPORT NUMBER(S)			
5a NAME OF PERFORMING ORGANIZATION Naval Underwater Systems Center		6b OFFICE SYMBOL (If applicable) Code 3552		7a NAME OF MONITORING ORGANIZATION		
6c ADDRESS (City, State, and ZIP Code) Newport Laboratory Newport, RI 02841-5047			7b ADDRESS (City, State, and ZIP Code)			
8a NAME OF FUNDING/SPONSORING ORGANIZATION Naval Sea Systems Command		8b OFFICE SYMBOL (If applicable) SEA 06C12		9. PROCUREMENT INSTRUMENT IDENTIFICATION NUMBER		
8c ADDRESS (City, State, and ZIP Code) Washington, DC 20362			10 SOURCE OF FUNDING NUMBERS			
			PROGRAM ELEMENT NO.	PROJECT NO.	TASK NO.	WORK UNIT ACCESSION NO.
11 TITLE (Include Security Classification) EVALUATION OF IBM PC-BASED AN/USM-465 WORKSTATION INTEGRATION PACKAGE						
12. PERSONAL AUTHOR(S) Kalisz, Michael S.						
13a. TYPE OF REPORT		13b TIME COVERED FROM _____ TO _____		14. DATE OF REPORT (Year, Month, Day) 86-9-22		15 PAGE COUNT 40
16 SUPPLEMENTARY NOTATION						
17 COSATI CODES			18. SUBJECT TERMS (Continue on reverse if necessary and identify by block number)			
FIELD	GROUP	SUB-GROUP	WORKSTATION INTEGRATION PACKAGE (WIP)			
14	02		GO/NOGO Test Programs MICRO COMPUTER			
09	02		AN/USM-465 NAVY STANDARD TEST PROGRAM SET			
19 ABSTRACT (Continue on reverse if necessary and identify by block number) The Workstation Integration Package (WIP) proved to be a useful tool in the development of GO/NOGO Test Programs for the AN/USM-465. The WIP provided both cost and time savings. Aside from one problem in the TRANSLT routine, the WIP functioned very well. Use of the WIP provided uniform and consistently high-quality test programs.						
20 DISTRIBUTION AVAILABILITY OF ABSTRACT <input checked="" type="checkbox"/> UNCLASSIFIED/UNLIMITED <input checked="" type="checkbox"/> SAME AS RPT <input type="checkbox"/> DTIC USERS				21. ABSTRACT SECURITY CLASSIFICATION UNCLASSIFIED		
22a NAME OF RESPONSIBLE INDIVIDUAL Michael S. Kalisz			22b TELEPHONE (include Area Code) (401) 841-3531		22c OFFICE SYMBOL Code 3552	

UNCLASSIFIED
 NAVAL UNDERWATER SYSTEMS CENTER
 NEWPORT LABORATORY, RI, NEWPORT, R.I. 02841
 TECHNICAL LIBRARY

ABSTRACT

The Workstation Integration Package (WIP) proved to be a useful tool in the development of GO/NOGO Test Programs for the AN/USM-465. The WIP provided both cost and time savings. Aside from one problem in the TRANSLT routine, the WIP functioned very well. Use of the WIP provided uniform and consistently high-quality test programs.

ADMINISTRATIVE INFORMATION

This evaluation was sponsored by the Naval Sea Systems Command, program manager--E. Johnson (SEA-06C12).

The author of this memorandum is located at the Newport Laboratory, Naval Underwater Systems Center, Newport, Rhode Island 02841.

TABLE OF CONTENTS

Section	Page
1 BACKGROUND.....	1
2 PURPOSE.....	1
3 SCOPE.....	1
4 EVALUATION.....	3
4.1 Evaluation Approach.....	3
4.2 Evaluation Procedure.....	3
4.3 Evaluation Analysis.....	4
5 SUMMARY.....	5
6 RECOMMENDATIONS.....	7
APPENDIX--OPERATING INSTRUCTIONS FOR IBM PC BASED AN/USM-465 WORKSTATION INTEGRATION PACKAGE.....	A-1

1. BACKGROUND

The Navy Standard Test Program Set (TPS) Development Station is an integrated system. It consists of: (1) an Automatic Test Program Generator (ATPG); (2) an Automatic Test System (ATS), which consists of Automatic Test Equipment (ATE) and TPSS; and (3) a Work Station Integration Package.

The WIP is a work station implemented on a microcomputer. The WIP performs the functions of:

- Interface and control of electronic module modeling and ATPG programs
- ATP development from the stimulus/response vectors of the ATPG system
- Interface and control of AN/USM-465 test program transfers between the workstation and the AN/USM-465.

The ATE would not be required until the final stages of TPS development. This equipment would be required only for loading the TPS and final TPS debug. This alleviates the need for the ATE throughout TPS development.

The objective is to take advantage of the cost and time savings inherent in modern microcomputers. Because of its ready availability and its position as a de facto standard for microcomputers, the IBM Personal Computer (PC) was selected to host the WIP. In November 1984, the U.S. Navy contracted with AAI Engineering Support, Inc., to provide an AN/USM-465 WIP for evaluation. This evaluation began in November 1984.

The evaluation system consists of a VAX-11/780 with a Hierarchical Integrated Test Simulator (HITS), telecommunications modems and multiplexers, an IBM PC, the WIP, and an AN/USM-465.

2. PURPOSE

The purpose of this report is to provide: (1) results of the WIP analysis and evaluation, and (2) make recommendations for further actions with the WIP.

3. SCOPE

The Navy Standard TPS Development Station contains the WIP and its interfaces, cables, switches, and modems necessary to connect the IBM PC to the VAX-11/780 and the AN/USM-465. The development station is illustrated in figure 1.

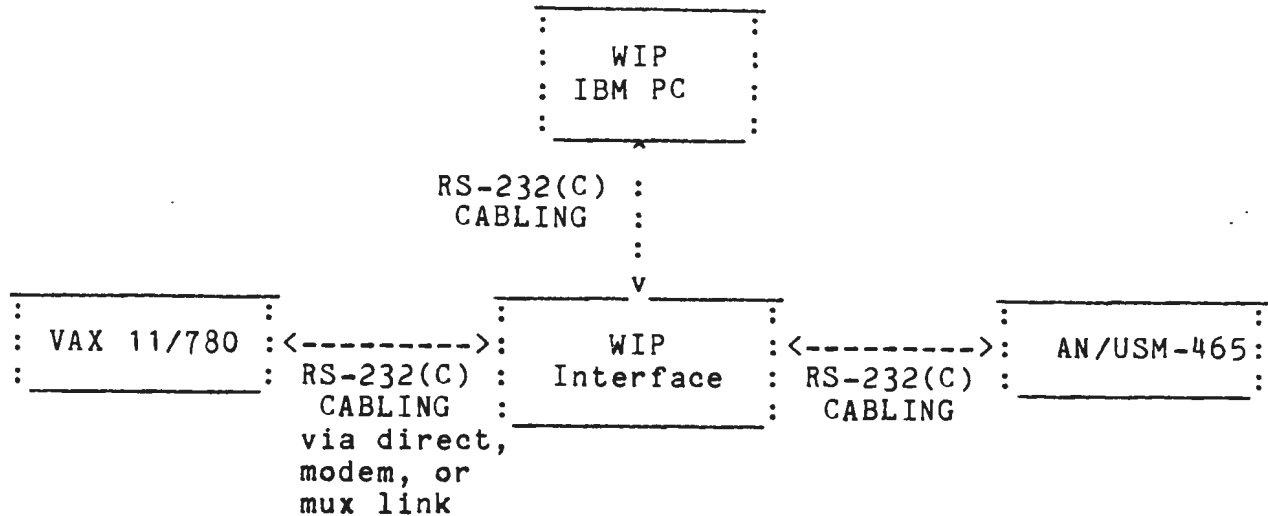

Figure 1. Navy Standard TPS Development Station

The WIP contains software, three RS-232(C) cables, and an WIP interface device. The specifications for the IBM PC required to run WIP software are as follows:

- IBM PC, XT
- IBM PC computer color display
- MS/DOS version 2 operating system
- IBM BASIC
- IBM serial communication board
- Printer with IBM parallel interface.

The software for the WIP consists of three routines:

- TRANSLT, which converts HITS digital simulator output data into GenRad BASIC test programs
- VAXLINK, which transfers files to and from the WIP to the VAX
- PSPLINK, which transfers files to and from the WIP to the AN/USM-465.

Further software and hardware architectural information is given in the appendix.

4. EVALUATION

4.1 EVALUATION APPROACH

Evaluation of the WIP was conducted by actually producing TPSs for the AN/USM-465 and performing product acceptance testing on the resulting test programs. These programs produced are screening (i.e., GO/NOGO) test programs and do not provide fault isolation.

Test program acceptance testing was accomplished by utilizing the following methods: (1) testing known "good" modules, and (2) inserting three (or more) module faults. These methods verify that the test programs properly identify the modules.

A set of 11 AN/UYK-7 digital circuit card assemblies (CCAs) were selected and test programs were developed for each. They are identified by UNIVAC CCA part number and are given as follows:

7093405	7093491
7093415	7093495
7093440	7112370
7093470	7139190
7093475	7165475
7093485	

These CCAs were selected because of their immediate applicability to the Trident program. Also, these test programs are not available in the Support and Test Equipment Engineering Program (STEEP) TPS inventory at the Fleet Analysis Center (FLTAC), Corona, CA.

For evaluation of the WIP station, test programs were executed on the AN/USM-465 using interface device (ID) number 1 from the AN/USM-602 and an interface cable constructed for that purpose. This approach was selected because 100 AN/USM-465 test programs had been successfully run utilizing this hardware configuration. Furthermore, this configuration avoided the use of family boards and the ID-00007, supplied with the STEEP test programs. (ID-00007 is unsuitable for Trident application. Its use requires the removal of the plastic keying pins on AN/UYK-7 cards, which the Trident program prohibits. Since the evaluation period, NUSC has developed an ID that does not require removal of these keying pins. The test programs ran on the new ID with no problems.)

4.2 EVALUATION PROCEDURE

The evaluation procedure used is as follows:

1. Preparatory to modeling the CCAs, in-depth reviews of the drawings, specifications, and parts' list for each CCA were conducted to determine test

strategy. In particular, the HITS library name of each CCA component was identified, component data requirements were listed, and places where fan-outs meant that an additional current source would have to be supplied were noted. If required, HITS macros were identified and specified. As data collection for a CCA proceeded, the HITS model information was documented on HITS model forms.

2. The WIP station VAXLINK program was executed to transfer data to and from the VAX-11/780 at FLTAC. The WIP was then used to: (a) control HITS, (b) enter HITS CCA model data, (c) enter test patterns taken from CCA test specifications, and (d) complete HITS test pattern output. Data collected included the final test patterns and the final figures on test comprehensiveness. Finally, HITS data were transferred to disk files on the IBM PC using VAXLINK.

3. The next step, processing HITS test pattern files to GenRad BASIC programs, required use of the WIP program TRANSLT. To execute TRANSLT requires three files:

- EQUATE.TAP
- (Board name).STM
- (Board name).RSP .

The (board name).STM and (board name).RSP data files are transferred via VAXLINK from HITS. The operator must use a suitable file creation program, e.g., the IBM PC editor, to create a file called EQUATE.TAP. EQUATE.TAP provides the input/output pin numbers and other control parameters required by TRANSLT. (For EQUATE.TAP details, see appendix.)

4. The next step required the use of WIP program PSPLINK to transfer completed test programs to the AN/USM-465 for acceptance testing.

5. The previous steps were repeated as required to complete test program debug. PSPLINK is also used to transfer files from the AN/USM-465 to the IBM PC for editing.

4.3 EVALUATION ANALYSIS

The first step of the test program development procedure did not involve the use of the WIP. Since the WIP was not used, it provided no time savings in TPS development.

In step 2, VAXLINK functioned well, allowing easy exchange of data and data files between the IBM PC and the VAX-11/780. Some minor program "bugs" were corrected by AAI Engineering Support, Inc., during the evaluation. VAXLINK was found to be a user-friendly, menu-driven routine, fully documented in the operating instructions found in the appendix. Note that the WIP

provides back-up capability on the IBM PC in the event of data loss in the VAX-11/780 or unexpected link failure. The remaining functions in step 2, control and execution of HITS, was readily supported by VAXLINK. Use of the WIP VAXLINK program provides no major time savings during HITS modeling except in the event of link failure to the VAX. In this case, one can continue to develop HITS models on the IBM PC and then transfer the model to the VAX when the link is "up."

In step 3, 11 test programs were developed using TRANSLT. The TRANSLT program worked well; however, there is an intermittent TRANSLT problem in the COMPRESS mode. The COMPRESS mode produces the clock and loop statements, but intermittently omits the NEXT instruction in FOR NEXT loops. AAI Engineering Support, Inc., has been notified of this problem and it is being addressed. Use of the WIP TRANSLT program provides an estimated time savings of 16 to 1 over the manual method of translating HITS data to a test program for the AN/USM-465.

In step 4, test programs were moved from the IBM PC to the AN/USM-465 with the use of PSPLINK. Transfer of test programs from the WIP to the AN/USM-465 was straightforward and followed the procedure given in the appendix. The test programs were transferred without problems.

The PSPLINK program also provides for transfer of test programs from the AN/USM-465 to the IBM PC for editing, hard-copy, and back-up. Use of the WIP PSPLINK program provided an estimated time savings of 60 to 1 over the manual method of entering a test program on the AN/USM-465. PSPLINK also provided an estimated time savings of 5 to 1 over the manual method during debug of the test programs requiring debug.

All test programs developed were then tested in accordance with normal test program acceptance procedures and accepted. There were no test program errors encountered attributable to the WIP other than the FOR NEXT loop problem.

5. SUMMARY

The evaluation procedure for developing test programs consisted of five steps:

- Collect data on the CCA, which will be required for HITS modeling
- Model the CCA for HITS and execute HITS to obtain test program data
- Translate HITS output data into a test program to run on the AN/USM-465
- Enter the program on the AN/USM-465 and execute it
- If required, debug the test program.

The WIP consists of three software routines, VAXLINK, TRANSLT, AND PSPLINK, which are designed to be run on an IBM PC. As a whole, the WIP is designed to provide a cost and time savings over previously used manual methods of test program development.

The first routine used in the evaluation was VAXLINK. VAXLINK was used in the second part of the evaluation procedure. Part 1 did not require the use of the WIP. VAXLINK was used to connect the IBM PC to the VAX-11/780. VAXLINK was used to:

- Enter HITS model information from the keyboard of the IBM PC
- Execute HITS from the keyboard of the IBM PC
- Transfer HITS output data from the VAX-11/780 to the IBM PC.

VAXLINK was found to be a user-friendly, menu-driven routine. There were some minor "bugs" in the routine; however, they were corrected during the evaluation period. There is no major time savings involved with the use of VAXLINK except in the case that the link to the VAX-11/780 fails. In this case, HITS modeling can continue locally on the IBM PC and then can be transmitted automatically to the VAX. Also, aside from being able to connect to a VAX-11/780, VAXLINK offers a menu-driven set-up routine, which allows the user to configure the communications port on the IBM PC. This allows the IBM to communicate to essentially any computer and function as a "smart" terminal.

Next, the WIP routine TRANSLT was used. Step 3 in the evaluation procedure required that HITS output data be translated to a test program to run on the AN/USM-465. Prior to executing TRANSLT, the user must first create a file called EQUATE.TAP (using a resident IBM editor). This file, EQUATE.TAP, provides TRANSLT the input/output pin numbers and other control parameters required by TRANSLT. TRANSLT did translate the HITS output data, transferred from the VAX-11/780, via VAXLINK, to a test program with TRANSLT in the COMPRESS mode (which produces clock and loop statements). It will intermittently omit the NEXT instruction in FOR NEXT loops. Presently, AAI Engineering Support, Inc., is addressing the problem. TRANSLT offers a means of ensuring uniform, high-quality test programs. TRANSLT also offers a significant time savings of approximately 16 to 1 over the manual method of translating HITS output data to a test program.

The last WIP routine used in test program development was PSPLINK. PSPLINK was used in parts 4 and 5 of the evaluation procedure. PSPLINK provided the means of automatically transferring the test program, provided by TRANSLT, to the AN/USM-465. The procedure for transferring the test program to the AN/USM-465 was straightforward. PSPLINK provided a time savings in part 4 of approximately 60 to 1 over the manual method of inputting a test program to the AN/USM-465. In part 5 of the evaluation procedure, PSPLINK provided a means of transferring the test program from the AN/USM-465 back to the IBM PC. This allows for editing test programs with editors resident on the IBM, hard-copy on full-size paper (8-1/2 inches x 11 inches as opposed to

the 2-1/4-inch wide printout on the AN/USM-465), a means of back-up on test programs on the IBM PC or on IBM floppy disks (even if the test programs were not developed using the WIP).

The evaluation was made by developing 11 test programs with use of the WIP. All 11 test programs were tested in accordance with normal test program acceptance procedures and were accepted.

The WIP proved to be a useful tool in the development of test programs for the AN/USM-465. It provided both cost and time savings. Aside from the one problem in the TRANSLT routine, the WIP functioned very well. Use of the WIP provided uniform and consistently high-quality test programs.

6. RECOMMENDATIONS

The following recommendations are made:

- As a final step in the evaluation process, and before a commitment is made to the TRANSLT program in the WIP, a full, independent, verification and validation of all test programs developed should be conducted.
- The WIP software should be placed under formal Navy configuration management. This action is considered mandatory, since there may be test program problem reports in the future traceable to TRANSLT or other WIP programs.
- On completion of the above, the hardware/software configuration tested can be accepted as an initial version of the Navy Standard TPS Development Station for AN/USM-465 test program development.

APPENDIX

OPERATING INSTRUCTIONS FOR IBM PC BASED AN/USM-465
WORKSTATION INTEGRATION PACKAGE*

*Reproduced with permission from AAI Engineering Support Incorporated

IBM PC Based AN/USM-465 Workstation Integration Package

Operating Instructions

Engineering Report ER-0056B

25 April 1985



AAI Engineering Support Incorporated _____

A wholly owned subsidiary of AAI Corporation • Box 10525, Baltimore, Maryland 21204 • (301) 628-0900

CONTENTS

<u>Section</u>	<u>Page</u>
1. INTRODUCTION	1
1.1 Overview	1
1.2 System Description	1
2. SYSTEM REQUIREMENTS	2
2.1 Hardware Requirements	2
2.2 Software Requirements	2
3. GETTING STARTED	3
3.1 Connecting the Workstation Interface Device (ID)	3
3.2 Backing up WIP Files	3
3.3 Commands, Directories, and File Names	5
4. OPERATING MODES	7
4.1 Transferring LASAR/HITS Data from VAX to IBM (VAXLINK)	7
4.2 Converting LASAR/HITS Data to PSP Basic (TRANSLT)	13
4.3 Transferring files between the IBM PC and AN/USM-465 (PSPLINK)	16
4.4 Editing PSP BASIC Programs (BASIC).	18

CONTENTS (CONTINUED)

<u>Section</u>		<u>Page</u>
5.	SPECIFICATIONS FOR IBM PC BASED AN/USM-465 WORKSTATION INTEGRATION PACKAGE	20
5.1	Software	20
5.1.1	Vaxlink Subprogram	20
5.1.2	Psplink Subprogram	21
5.1.3	Translt Subprogram	21
5.2	Hardware-Workstation Interface Device	21

1. INTRODUCTION

1.1 OVERVIEW

This manual describes the capabilities, installation, and operation of the IBM PC Based AN/USM-465 Workstation Integration Package (WIP). Section 1 of this manual gives a general description of WIP, its uses, and operation. Section 2 lists the hardware/software required to operate WIP. Section 3 explains how to set up the IBM PC to run WIP. Section 4 gives a detailed description of how to operate WIP. Section 5 lists the specifications of WIP.

1.2 SYSTEM DESCRIPTION

WIP was developed to provide a low cost edit station for PSP BASIC Programs, and to provide a means for translating LASAR/HITS data on a VAX 11/7XX Series computer into a PSP BASIC program on an AN/USM-465. The WIP functions are accomplished by four programs: VAXLINK, TRANSLT, BASIC, and PSPLINK. All of these programs are included in the WIP package, with the exception of BASIC which comes with the IBM PC. Each of these programs controls one of four modes of operation. The four modes of operation are: transfer of LASAR/HITS data files from VAX to IBM PC files, translation of LASAR/HITS files into a PSP BASIC program file, editing of PSP BASIC programs on the IBM PC, and transfer of PSP BASIC files between the IBM PC and the AN/USM-465 tester.

Some of the advantages of WIP are: PSP programs can be displayed on the 80 column by 24 line CRT display of the IBM instead of the LED display of the PSP; programs can be listed on standard 80 or 132 column computer paper instead of the 20 column thermal printer on the PSP; programs can be edited using the full-screen BASIC editor instead of the line editor of the PSP; LASAR/HITS data can be converted directly into PSP BASIC; allows tester resources to be devoted solely to program validation and verification. In addition, all of the normal capabilities of the IBM PC are available. WIP does not require any changes to the IBM PC operating system or hardware.

2. SYSTEM REQUIREMENTS

2.1 HARDWARE REQUIREMENTS

The following hardware is necessary to operate the WIP package:

IBM PC with:

- color/graphics adapter or 80 column B&W card
- 5 1/4" double sided double density floppy disk drive
- RS232 port in the COM1 position
- printer (needed only for listing programs on IBM PC)
- 640K internal RAM
- 10 Mega bytes of disk storage is recommended

VAX 11/7XX Series computer with:

- RS232 terminal connection using XON/XOFF protocol or a modem interface and modem with RS232 connection

AN/USM-465 Tester Workstation Interface Device (ID)

- included in WIP package

Three RS232 cables:

- 1 cable with female connectors on each end to connect the IBM PC to the Workstation Interface Device (ID)
- 1 cable with male connectors on each end to connect the AN/USM-465 to the ID
- 1 cable to connect the ID to the terminal or modem connector
- included in WIP package are three 25 foot RS232 cables

2.2 SOFTWARE REQUIREMENTS

The following software is necessary to operate the WIP package:

IBM Software

- PC DOS
- BASIC
- WIP software disk (included in WIP package)

VAX Software (only needed for LASAR/HITS translator)

- LASAR with LASAR tape (LSRTAP)
- or HITS

3. GETTING STARTED

This section describes how to use the WIP including: connecting the Workstation Interface Device (ID), turning on the IBM PC, and backing up files on the WIP disk. Section 3.1 describes how to connect the Workstation ID. Section 3.2 describes how to turn on the IBM PC and make backup copies of the WIP files. Section 3.3 gives some general information on how to enter commands, directory names, and file names.

3.1. CONNECTING THE WORKSTATION INTERFACE DEVICE (ID)

Three RS232 cables are required to connect the ID. Three 25 foot RS232 cables are included in the WIP package. These cable lengths will be adequate for most user requirements.

To connect the ID:

1. Position the ID so that the three RS232 connectors are facing you - with the two female connectors above the single male connector.
2. Connect the first cable (female connectors on both ends) between the IBM PC RS232 port and the bottom connector on the ID.
3. Connect the second cable (male connectors on both ends) between the AN/USM-465 RS232 port and the upper-left connector on the ID.
4. Connect the third cable between the upper-right connector on the ID (male connector end of cable) and the VAX terminal line or modem RS232 connector.

The switch on the ID must be moved to the side labeled "VAX Port" to communicate with the VAX, or to the side labeled "465 Port" to communicate with the AN/USM-465 tester.

3.2 BACKING UP WIP FILES

The following steps explain how to make a backup copy of the WIP disk on both the IBM hard disk and another 5 1/4" floppy disk.

1. Start the IBM PC using the DOS disk supplied by IBM:
Place the DOS disk in drive A (drive on left), close the drive door, then turn on the IBM. After a short time you will be prompted to enter the current time and date. At 1:30 p.m. on October 1, 1984 you would see and enter:

Current date is Tue 1-01-1980

Enter new date: 10-01-84

Current time is 0:00:41.30

Enter new time: 13:30

You will now see a copyright message followed by the prompt "A>" this means that drive A is the default drive.

2. Remove the DOS disk from drive A.
3. Place the WIP disk in drive A.
4. Make the hard disk the default drive. If the hard disk is drive C type: C:
5. Use the DOS command CHDIR to change the default directory to the one you want to load the WIP files into. If the directory does not exist then use the MKDIR command to create the directory. To create the directory WIP type:

MKDIR\WIP

To make the new "WIP" directory into the default directory type:

CHDIR\WIP

6. To copy all the files from the WIP disk to the default directory type:

COPY A: *.*

7. The WIP files cannot be executed from the hard disk until they are installed. To install the WIP files (if the hard disk is drive C) type:

A:HDINSTAL C:

The original WIP disk must be on drive A before this command is entered.

WARNING:

The HDINSTAL program should only be run when the WIP programs are first copied onto the hard disk or after the hard disk has been reformatted. HDINSTALL can only be run two times.

8. Remove the WIP disk from drive A.

To backup the WIP files on another floppy:

1. Place a formatted 5 1/4" floppy disk in drive A. (See page 2-89 of the IBM DOS manual for information on formatting disks).
2. Make the new disk the default disk by typing: A:
3. Copy the files from the hard disk directory. If the hard disk directory is WIP in drive C type:

```
COPY C:\WIP\ *.*
```

Note: The ORIGINAL WIP disk must always be in drive A or the WIP programs must be installed on the hard disk in order to start any of the WIP programs.

3.3 COMMANDS, DIRECTORIES, AND FILE NAMES

This section provides a brief explanation of how to enter commands, directory names, and file names. A more detailed description is provided in the IBM Disk Operating System Manual.

Commands: When a command is entered on the IBM PC, the Disk Operating System checks if the command is a standard DOS command. If the entered command is a standard DOS command, the DOS will execute the command. If the entered command is not a standard command then DOS searches the current directory for a file with the same name as the entered command but with an extension of .COM, .BAT or .EXE. If one of these files exists then DOS runs the file; if none of these files exists then DOS prints the message "Bad command or file name".

If you want to run the program VAXLINK.EXE in the directory \WIP, but you want to keep \LASAR as your default directory then you must tell DOS to search the \WIP directory for .COM, .BAT, and .EXE programs by using the DOS PATH command. To make DOS search the \WIP directory as well as the current directory type:

```
PATH\WIP
```

The PATH command will let you run the WIP programs regardless of what directory you are currently in.

Note: The ORIGINAL WIP disk must always be in drive A or the WIP programs must be installed on the hard disk in order to start any of the WIP programs (see Section 3.2 for instructions on installing the WIP programs).

Directories: IBM directories are set up in a "tree structure", which means that each directory can have sub-directories within it. To specify a directory which is a sub-directory of the current directory, use just the sub-directory name. To specify a directory which is a sub-directory of the main directory, put a "\" before the directory name. To specify "WIP" if it is a sub-directory of the current directory type "WIP" as the directory name. If the directory "WIP" is a sub-directory of the main directory use "\WIP" as the directory name.

File names: All of the WIP programs allow drive and directory names to be specified with the file name. The drive name must be first (if it is used) and it must be separated from the rest of the file description by a ":". The directory name (if used) comes after the drive name but before the file name. The directory name must be separated from the file name by a "\". All IBM file names can be 1 to 8 characters long and may have an extension 0 to 3 characters long. The extension is included after the main part of the file name and must be separated from the file name by a period.

Example:

```
C:\LASAR\BASIC.PSR
```

This specifies the file BASIC, with the extension PSR, in the directory LASAR on drive C.

4. OPERATING MODES

The WIP has four operating modes: transfer of LASAR/HITS files from the VAX to the IBM PC, translation of LASAR/HITS files to PSP BASIC, transfer of files between the IBM PC and AN/USM-465, and editing of PSP BASIC files on IBM PC. Each one of the modes is controlled by a separate program: VAXLINK, TRANSLT, PSPLINK, or BASIC. The first three programs are on the WIP disk, the fourth program comes on the IBM DOS disk (in the back of the Disk Operating System Manual by IBM).

Note: The ORIGINAL WIP disk must always be in drive A or the WIP programs must be installed on the hard disk in order to start any of the WIP programs (see Section 3.2 for instructions on installing the WIP programs).

4.1 TRANSFERRING LASAR HITS DATA FROM VAX TO IBM (VAXLINK)

The WIP program VAXLINK.EXE controls the transfer of data between the VAX and the IBM PC. Before running VAXLINK the switch on the Workstation Interface Device must be set to the "VAX PORT" position. VAXLINK can be used to transfer any text file from the VAX to the IBM PC, or from the IBM PC to the VAX, not just LASAR/HITS files. The only limitation is that files transferred from the VAX to the IBM must not have a '\$' character immediately after either a carriage return or a line feed. VAXLINK uses the '\$' prompt to find the end of all VAX files. The VAX computer must print the VMS '\$' prompt immediately after either a line feed or a carriage return, without any null or blank characters in between, or else VAXLINK will not recognize the end of a file correctly.

If the VAX sends nul characters after a line feed or carriage return, then the commands:

```
SET TERMINAL/CRFILL = 0
SET TERMINAL/LFFILL = 0
```

should be used to eliminate the nul characters. The command:

```
SET TERMINAL/NOWRAP
```

should be used to eliminate extra line feed on lines which are greater than 80 characters long.

When VAXLINK is executed, the first screen that will appear is a menu of communication characteristics that VAXLINK will use to communicate to the VAX. The arrows on the IBM PC's numeric keypad are used to change the communication characteristics. The left and right arrows are used to select the characteristic to change. The value of the selected characteristic is highlighted on the IBM PC Monitor. The up and down arrows are used to change the value of the selected characteristic.

The communication characteristics and their possible values are:

CHARACTERISTIC	VALUES
Baud Rate	50, 75, 110, 134.5, 150, 220, 300, 600, 1200, 1800, 2000, 2400, 3600, 4800, 7200, 9600, Baud
Word Length	5, 6, 7, 8 bits
Stop Bits	1, 2 bits
Parity Bit	enable, disable
Parity Select	odd, even, force hi, force low
Break	standard DTR
Incoming XOFF	enable, disable
Auto XOFF	enable, disable
Background Color	blue, green, cyan, red, magenta, brown, light grey, dark grey
Foreground Color	blue, green, cyan, red, magenta, brown, light grey, dark grey, light blue, light green, light cyan, light red, light magenta, yellow, white
Control Characters	visible, ignore
Local Echo	enable, disable
HITS File	enable, disable
COM PORT	COM1, COM2

The following table describes each of the characteristics:

CHARACTERISTICS	DESCRIPTION
Baud Rate	Transmit and receive speed which VAXLINK will use to communicate to the VAX.
Word Length	The number of data bits transmitted and received.
Stop Bits	The number of stop bits transmitted at the end of each word.
Parity Bit	Enables/disables the transmission and checking of a parity bit after each word.
Parity Select	Selects the type of parity to be transmitted and checked during reception. This characteristic has no effect if PARITY BIT is disabled.
Break	Selects the type of break signal to be transmitted when both the control and the break keys are pressed. If set to DTR then a four second pulse is sent on the DTR line. If set to standard then a four second pulse is sent on the TD line.
Incoming XOFF	When enabled, VAXLINK will halt transmission after an XOFF (Control S) is received, until an XON (Control Q) is received.
Auto XOFF	When enabled, VAXLINK will transmit an XOFF to the VAX when the input buffer is full or during disk access in order to avoid loss of data.
Background Color	Selects the color of the display window on the IBM PC Monitor.
Foreground Color	Selects the color of characters appearing within the display window.
Control Characters	When set to ignore: all control characters with the exception of tab, carriage return, null, backspace, and line feed, are ignored. When set to visible: the hex value for all received control characters is displayed within angle brackets.
Local Echo	When enabled, characters are displayed on the screen as soon as they are typed. When disabled, VAXLINK waits for the host computer (VAX) to echo back characters before displaying.
HITS File	When enabled, a special compression routine is used on files during transfers. This should be enabled ONLY when transferring HITS data files.
COM Port	This selects the IBM PC communication port to be used to communicate with the VAX.

If the communication parameters are not set correctly then VAXLINK will make a clicking noise whenever a transmission error occurs. The selected communication parameters will not go into effect until the setup procedure is exited so the IBM PC may continue to click even though the screen shows the correct communications setup.

To exit the VAXLINK setup menu hold down the 'ALT' key and press the 'F10' key (ALT-F10). The characteristics which were selected in the setup menu will now go into effect.

Exiting the setup menu transfers control to the VAXLINK terminal emulation routine. This routine makes the IBM PC behave like a terminal with a few added features which are activated by pressing the function keys.

Pressing the 'F1' key makes VAXLINK display a description of the function of each of the function keys. Control is returned to the terminal emulator.

Pressing the 'F2' key transfers control back to the VAXLINK setup routine for correcting communication characteristics. Pressing ALT-F10 returns control to the VAXLINK terminal emulator.

Pressing the 'F3' key starts the IBM to VAX transmission routine. If you want to transfer data to a VAX file then you must start the VAX EDT or SOS editor and enter the insert mode before pressing the 'F3' key. After pressing the 'F3' key you must enter the name of the IBM file you want to send. The data being transferred will be displayed on the screen as it is transferred until the space bar is pressed; pressing the space bar again will re-enable display of transmitted data. Pressing ALT-F10 will abort a transfer and return control to the terminal emulator. When the transfer is complete, the message 'TRANSMISSION COMPLETE' is displayed and control is returned to the terminal emulator.

Pressing the 'F4' key starts the VAX to IBM transmission routine. After pressing 'F4' enter the name of the VAX file that you want to load into the IBM PC. Next, enter the name you want the file to be called on the IBM PC; if you just press the enter key then the VAX file name will be used. The transmission will take place in the same manner as with IBM to VAX transmission. The space bar and ALT-F10 keys have the same effect as in the IBM to VAX transmission. Make sure that the HITS FILE setup option is set correctly before beginning transmission.

Pressing the 'F5' key starts and stops capture of incoming data to an IBM PC file. After pressing the 'F5' key for the first time, you must enter the name of the IBM PC file which you want data to be written to (the capture file). Then, VAXLINK will return to the terminal emulation mode. Now all data which is sent from the VAX to the IBM will also be written to the capture file. When the 'F5' key is pressed again, the capture file will be closed and no more data will be written to the file. Pressing the F2, F3, F4, F7, F8 or ALT-F10 key will also cause the capture file to be closed. Control is returned to the terminal emulator.

Pressing the 'F6' key will pause or un-pause capture of incoming data. Data capture must be started ('F5' key) before it can be paused. The first time that the 'F6' key is pressed, incoming data will no longer be written to the capture file (capture paused), but the capture file will not be closed. Pressing the 'F6' key again will resume normal operation of the capture file. Control is returned to the terminal emulator.

Pressing the 'F7' key makes VAXLINK display the names of files in the current directory. After pressing the 'F7' key, you must enter the mask that will be used to search for file names. If you just enter return then the default mask of '*' will be used so that all files will be listed. This command works in the same way that the IBM DOS 'DIR' command works. Control is returned to the terminal emulator.

Pressing the 'F8' key displays or changes the current default directory. After pressing the 'F8' key, you must enter the name of the new directory. If return is pressed, without entering a name then the default directory will not be changed. If an invalid directory name is entered then an error message is printed and the default directory is not changed. This command works in the same way that the IBM DOS 'CHDIR' command works. The name of the default directory is printed before control is returned to the terminal emulator.

Pressing the CONTROL and BREAK keys at the same time will send a four second break pulse to the VAX. The IBM PC will not accept data from the keyboard, and the screen may momentarily go blank, when the break pulse is sent. Control is returned to the routine which was active before CONTROL-BREAK was pressed.

Pressing the CONTROL and SCROLL LOCK keys at the same time will pause the printing of data on the IBM PC Monitor until any other key is pressed. Control is returned to the routine which was active before CONTROL-SCROLL LOCK was pressed.

To exit VAXLINK, when in the terminal emulator, press ALT-F10. Control is returned to IBM PC DOS.

Before LASAR data is transferred, LASAR TAPE (LSRTAP) must be run on the VAX with the /NOTAPE option. This will produce the files: STIMULUS.TAP, RESPONSE.TAP, PINAMES.TAP, and PONAMES.TAP. All four of these files must be transferred to the IBM PC to translate the LASAR data into a PSP BASIC program.

Use the following steps to transfer a file from the VAX to the IBM PC:

1. Set the switch on the Workstation Interface Device to the "VAX Port" position.
2. Type "VAXLINK" (the IBM will now act like a VAX terminal).
3. Set the communication parameters for your system.
4. Press ALT-F10 to enter the terminal emulator.
5. Log on to the VAX and enter the directory containing the simulator files.
6. Press the "F4" key. This ends the terminal emulation and enters the VAX to IBM file transfer routine.
7. For LASAR files: enter the name of the LASAR .TAP file that you want to transfer (stimulus, response, pinames, and ponames must be transferred). For HITS files: Enter the name of the HITS file you want to transfer (the .STM and .RSP files must be transferred).
8. The prompt "IBM FILE NAME" will now appear followed by the name of the file specified in step 7. Press return to use the same name for the IBM file, (this must be done for HITS and LASAR files), or type in a new name for the file.
9. The file will list on the display as it is transferred. To disable listing the file during the transfer, press the space bar - this will increase the transfer rate. To abort a transfer press ALT-F10.
10. The message "TRANSFER COMPLETE" will appear as soon as the transfer is finished. Then you can:
 - A) Press the "ALT-F10" key to exit VAXLINK.
 - B) Press the "F4" key to transfer another file (go back to step 7).
 - C) Press the "F1" key for help.
 - D) Press the "F2" key to change communication parameters.
 - E) Press any of the function keys listed above.
 - F) If no function key is pressed then VAXLINK remains in the terminal emulation mode.

4.2 CONVERTING LASAR/HITS DATA TO PSP BASIC (TRANSLT)

The WIP program TRANSLT.EXE translates the LASAR .TAP files or HITS files in the current directory to a PSP BASIC file in the current directory. Before TRANSLT is run, a file named EQUATE.TAP must be created manually. This contains data which is used to create the EQUATE statements for the PSP BASIC program and options for TRANSLT. The options are used to control the way that TRANSLT converts simulator data into a PSP BASIC program. The options and their default values are:

OPT. #	OPTION SYNTAX	DEFAULT
0	\$ FIRST EQUATE (LINE) (=) Line Number	FIRST EQUATE LINE = 1000
1	\$ FIRST PATTERN (LINE) (=) Line Number	FIRST PATTERN LINE = 1500
2	\$ LINE INCREMENT (=) Number	LINE INCREMENT = 2
3	\$ LINE LENGTH (=) Number	LINE LENGTH = 120
4	\$ [NO] EQUATES	EQUATES
5	\$ [NO] COMPRESS	COMPRESS
6	\$ [NO] OUTPUTS	OUTPUTS
7	\$ NAME (=) Filename	NAME = BASIC.PSR
8	\$ MERGE (=) Filename	No merge file
9	\$ [NO] LOOPS	LOOPS
10	\$ [NO] CLOCKS	CLOCKS
11	\$ ISIG (=) Pattern Number	ISIG = 0
12	\$ BIDIRECTIONAL CHARACTER = Character	BIDIRECTIONAL CHARACTER = .
13	\$ [NO] HITS	HITS
14	\$ [NO] LASAR	NO LASAR

The option lines are included in the EQUATE.TAP file as shown in the OPTION SYNTAX column. Only the first three letters of each keyword is recognized. The words in parentheses are optional. All option statements must be preceded by a '\$'. There must be at least one space between each word. A space after the '\$' is optional. The key words which are preceded by [NO], such as [NO] CLOCKS, are disabled if the NO is included in the statement, and enabled if the NO is excluded.

Examples:

- 1) If the line \$ NO CLOCKS is included in the EQUATE.TAP file then no clock statements will be produced in the BASIC file.
- 2) If the line \$ CLOCKS is included in the EQUATE.TAP file then clock statements will be produced in the BASIC file.
- 3) The following lines are all valid and have the same meaning to TRANSLT:

```
$ FIRST EQUATE LINE = 100
$ FIR EQU LIN = 100
$ FIR EQU = 100
$ FIR EQU 100
$ FIRST EQU 100
$ FIRST EQU 100
```

The following table describes each of the options:

OPTION	DESCRIPTION
FIRST EQUATE LINE = Line Number	The EQUATE statements in the BASIC file will start at statement Line Number.
FIRST PATTERN LINE = Line Number	The first stimulus/response statement in the BASIC file will be Line Number.
LINE INCREMENT = Number	The increment between line numbers in the BASIC file will be Number.
LINE LENGTH = Number	This selects the maximum number of characters in a BASIC line. This number should be no larger than 250.
[NO] EQUATES	When enabled, EQUATE statements will be included in the BASIC file. When disabled, no EQUATE statements will be produced.
[NO] COMPRESS	When enabled, loop and clock statements will be used to compress the BASIC file. When disabled, no clock or loop statements will be used.
[NO] OUTPUTS	When disabled, no output statements will be included in the BASIC file.
NAME = File Name	Sets the BASIC file to File Name.
MERGE = File Name	The file File Name will be inserted at the beginning of the BASIC file; this can be used to insert header information.
[NO] LOOPS	This enables/disables the use of FOR-NEXT loops to compress the BASIC output file. The COMPRESS option, if specified, will override this option.
[NO] CLOCKS	This enables/disables the use of clock statements to compress the BASIC output file. The COMPRESS option, if specified, will override this option.

(Continued)

OPTION	DESCRIPTION
ISIG = Pattern Number	This option specifies which pattern the UUT is initialized on. If this is not specified then TRANSLT will scan the outputs until the last X-state is found; however, there may still be some uninitialized internal nodes.
BIDIRECTIONAL CHARACTER = Char	Bidirectional pins are recognized by having the input and output pin names the same except that the output name also has the character Char on the end. The input pin must be first in the EQUATE.TAP file.
[NO] HITS	This is used to select the use of HITS or LASAR input data.
[NO] LASAR	This is the opposite of the HITS option.

Lines in the EQUATE.TAP file which start with an "*" are assumed to be comments.

For LASAR files: Before TRANSLT is run, the LASAR TAPE files STIMULUS.TAP, RESPONSE.TAP, PINAMES.TAP, and PONAMES.TAP must be transferred from the VAX to the IBM PC.

The EQUATE.TAP file must also contain the name of each LASAR Primary Input (PI) and Primary Output (PO) pin followed by a comma, and then the number of the PSP pin that corresponds to the LASAR pin name. Only one PI/PO and PSP pin pair can be on a line.

For HITS files: Before TRANSLT is run, the HITS files Board Name.STM and Board Name.RSP must be transferred from the VAX to the IBM PC. The EQUATE.TAP file must also contain a cross reference between the HITS stimulus/response bits, tester pin numbers, and UUT pin names. The format of these lines is:

Pin Name, Tester Pin Number, HITS Stim/Resp Bit Number

The HITS Stim/Resp bit number specifies which output/input bit this pin represents. Stimulus pins are designated by a positive bit number and response pins are designated by a negative bit number.

Example:

If the UUT pin 'SCLK' is tester pin 5 and the first HITS stim pin, then the line

```
SCLK,5,1
```

will be in the EQUATE file. If 'SCLK' was the third HITS response pin then

```
SCLK,5,-3
```

will be in the EQUATE.TAP file.

For both HITS and LASAR files: A file called TRANSLT.LIS is produced each time TRANSLT is run. This file contains information which can be useful if errors are encountered in the input files used by TRANSLT.

To run the translation program type:

```
TRANSLT
```

If you do not specify OUTPUTS or NO OUTPUTS in the EQUATE.TAP file then you will be prompted with:

```
Do you wish to have the output responses compiled?
```

Enter "N" if you want to learn the outputs from a known good board, enter "Y" if you want the output states to be included in the BASIC statements.

4.3 TRANSFERRING FILES BETWEEN THE IBM PC AND AN/USM-465 (PSPLINK)

The WIP program PSPLINK.EXE controls the transfer of data between the IBM PC and AN/USM-465. Before running PSPLINK, turn the switch on the ID to the "465 Port" position. To run this program type:

```
PSPLINK
```

Now all commands are entered from the AN/USM-465 (PSP). Only two keys on the IBM keyboard will have an effect:

1. Holding down the 'ALT' key while pressing the F10 key will abort PSPLINK and return control to IBM DOS.
2. Pressing the space bar will disable listing of files during transfer, increasing the transfer rate. Pressing the space bar again will re-enable the listing.

The first command that must be entered on the PSP is:

```
ORG 9600 (execute)
```

Then any one of four commands may be entered on the PSP. The four commands are: LOAD, SAVE, LOGON, LOGOFF. You must specify a file name with the LOAD and SAVE commands. The file name must be one to six characters long and have an extension which is one to three characters long. The file extension must start with an "I" for image files, or "H" for HSP routines. All other files are assumed to be BASIC text files. IBM drive and directory names can also be included before the file names.

The following is a description of each of the commands:

The LOAD command - the LOAD command loads a specified file from the IBM PC into the memory of the PSP. The syntax for the LOAD command is:

LOAD file name (execute)

Example:

LOAD BASIC.PSR (execute)

If a syntax error is encountered in a program file during a load an error message is printed by the PSP when the line is transferred. The line is discarded by the PSP and transfer continues with the next line of the file.

The SAVE command - the SAVE command saves the program currently in the PSP's memory to the specified file on the IBM. The syntax for the SAVE command is:

SAVE file name (execute)

Example:

SAVE BASIC.PSR (execute)

The LOGON command - the LOGON command changes the default directory on the IBM PC. The syntax for the LOGON command is:

LOGON (execute)

directory (execute)

Example:

LOGON (execute)

\LASAR (execute)

Note: The LOGON command works the same way that the CHDIR command works in IBM PC DOS (SEE DOS Manual page 2-35). IBM DOS maintains a default directory for each drive and the LOGON command only changes the default directory for the drive specified with the directory name; LOGON will not make the specified drive become the new default drive. To load from a drive, other than the default drive when PSPLINK is started, you must include the drive identifier as part of the file name.

Example:

To load the file 'BASIC.PSR' from drive A, directory "SUBDIR1/SUBDIR2" with the following conditions:

Default drive = C:
Drive A default directory = /SUBDIR1

Type: .
LOGON (execute)
A:SUBDIR2 (execute)

This changes the default directory on drive A to /SUBDIR1/SUBDIR2.

Next type:

LOAD A:BASIC.PSR

This loads the file BASIC.PSR from the default directory on drive A. If the A: was not used, then the default directory on the default drive (drive C) would be searched for the file.

The LOGOFF command - the LOGOFF command causes PSPLINK to stop running on the IBM PC and returns control of the IBM PC to IBM DOS. The syntax for the LOGOFF command is:

LOGOFF (execute)

4.4 EDITING PSP BASIC PROGRAMS (BASIC)

PSP BASIC programs can be edited on the IBM PC by using the BASIC editor supplied by IBM. A full explanation of the editor's capabilities are in the BASIC manual. To run the BASIC editor type:

BASIC

To load the file to be edited type:

LOAD "filename"

To save the file after editing type:

SAVE "filename",A

The ".A" must be included or else the file will not be saved in a format that the PSP can read. There is one problem with the BASIC editor: if a number ends with a period, the BASIC editor will change the period to an exclamation point.

Example:

SET (10,5.) will change to SET (10,5!). The PSPLINK program has been written to allow for this bug; when the program is transferred from the IBM to the PSP, all exclamation points are changed to periods.

Text editors can also be used to edit the AN/USM-465 BASIC source code files. The editor must not insert any special control characters into source files. "Word Star" is among the editors which have this capability. Text editors are useful when global replacement of character strings is necessary; however, for general program development, the IBM PC BASIC editor is easier to use than most text editor.

5. SPECIFICATIONS FOR IBM PC BASED AN/USM-465 WORKSTATION INTEGRATION PACKAGE

The AN/USM-465 Test Program Set Development Workstation Integration Package provides a capability to develop AN/USM-465 test programs using the IBM PC. The Hardware/Software package described below provides the user with an offline full-keyboard, full-screen editor that can be interfaced to both the VAX 11/7XX computer and the AN/USM-465 tester. Tester time can be completely devoted to the validation and verification aspects of TPS development while the time-consuming phase of program development can be accomplished on an IBM PC using resident editor capabilities. These software packages provide cost and time-efficient capabilities for the TPS development process.

Features

- IBM PC based 465 Workstation
- offline program development with IBM PC editors
- LASAR/HITS automatic test program generation translation
- up to 9600 baud communication links
- Workstation Interface Device hardware interconnects the VAX 11/7XX, IBM PC, and AN/USM-465 tester

5.1 SOFTWARE

The Workstation software is comprised of the following subprograms:

5.1.1 VAXLINK SUBPROGRAM

This software package provides direct communications with a VAX 11/7XX series computer through the RS232 serial communications port, providing the IBM PC with the capability of emulating a terminal for the system. The VAXLINK program allows downloading of LASAR/HITS Test Simulator data from the VAX 11/7XX to the IBM PC and uploading of files from the IBM PC to the VAX 11/7XX. The program utilizes specially designed high-speed disk input/output routines which increase communication rates and reduce data transfer times. The program handles all communication protocol necessary for successful transfer of data and allows the user to change the communication characteristics to match his system configuration.

Features

- LASAR/HITS file downloading capability
- source file uploading
- VAX terminal operation
- serial communications via an RS232 port
- high speed AAI-ESI developed disk I/O routines
- user variable communication characteristics using VAX protocol

5.1.2 PSPLINK SUBPROGRAM

This software package provides direct communications with an AN/USM-465 through the RS232 serial communications port. With this program the capability of developing an AN/USM-465 program on the IBM PC is available. Offline program development will allow tester time to be dedicated to validation and verification of programs. All AN/USM-465 protocol is handled by the software package. Uploading and downloading of data between the IBM PC and AN/USM-465 tester is accomplished at 9600 baud and files that must be transferred may occupy up to the AN/USM-465 tester limit of 60 KB.

Features

- Workstation Interface Device hardware necessary for operation
- 9600 baud communication
- communication via RS232 serial communication port
- communication using AN/USM-465 protocol
- downloading capability from the IBM PC to the AN/USM-465
- uploading capability from the AN/USM-465 to the IBM PC

5.1.3 TRANSLT SUBPROGRAM

This software package provides the IBM PC with the capability to postprocess LASAR/HITS generated files into a file which can be executed on the AN/USM-465. Patterns generated by LASAR/HITS are analyzed and configured into the AN/USM-465 program language. The LASAR based postprocessor, LSRTAP, is used to create the files necessary for TRANSLT. The HITS post processor is built into TRANSLT. Minimal restrictions are placed upon the operator when developing the LASAR/HITS program to ensure a successful TRANSLT run. This program, in conjunction with VAXLINK and PSPLINK, allows LASAR/HITS generated test programs to be developed and reviewed on the IBM PC and then downloaded to the AN/USM-465.

Features

- LASAR/HITS pattern generation and compilation using VAX 11/7XX
- LASAR/HITS to AN/USM-465 translation
- model verification
- pattern validation

5.2 HARDWARE-WORKSTATION INTERFACE DEVICE

The Workstation Interface Device is the hardware interface that connects the IBM PC to the VAX 11/7XX computer and the AN/USM-465 tester. Included is the required RS232 connector and switching network to transfer data between the VAX and the AN/USM-465. Standard RS232 cabling is necessary for integrating

this package into a system. Included with the Workstation Interface Device are three 25 foot RS232 cables. These cable lengths will be adequate for most user requirements.

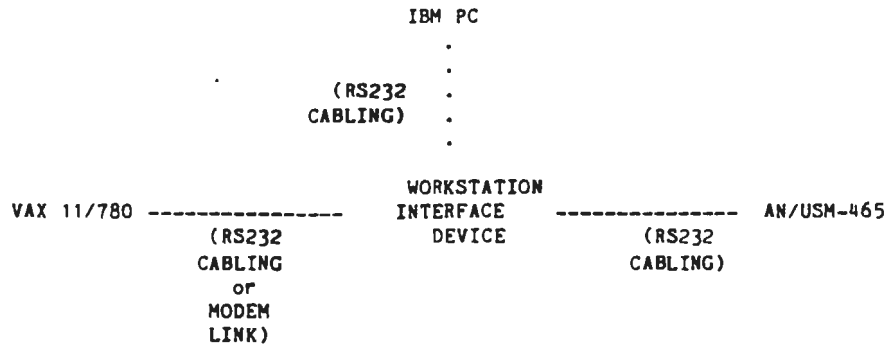

EVALUATION OF IBM PC-BASED AN/USM-465 WORKSTATION
INTEGRATION PACKAGE

Michael S. Kalisz

Operational Systems Division

Combat Control Systems Department

TM No. 86-2065

22 September 1986

APPROVED FOR PUBLIC RELEASE; DISTRIBUTION IS UNLIMITED

DISTRIBUTION LIST

External

DTIC, Alexandria (2)

Internal

Codes: 35
38
389
80
83.
355
3522 (R. Kalisz (5))
02134
0211 (R. Bernier)
02112 (R. Robertshaw)
02151 (New London)
02152 (Newport (2))

Total: 19