



841026 001N

REFERENCE ONLY

NUSC TM 841026

*cy001*

NAVAL UNDERWATER SYSTEMS CENTER  
NEW LONDON LABORATORY  
NEW LONDON, CT 06320

Technical Memorandum

The Production and Utilization of a Synthetic  
Sampling Frequency as Applied to Quadrature  
Demodulation for Envelope Detection

Date: 5 April 1984

Prepared by:

*Joseph M. Monti*

Joseph M. Monti  
General Engineer, 3331

DISTRIBUTION STATEMENT "A"  
Approved for public release  
Distribution unlimited

REFERENCE ONLY

## Report Documentation Page

*Form Approved*  
*OMB No. 0704-0188*

Public reporting burden for the collection of information is estimated to average 1 hour per response, including the time for reviewing instructions, searching existing data sources, gathering and maintaining the data needed, and completing and reviewing the collection of information. Send comments regarding this burden estimate or any other aspect of this collection of information, including suggestions for reducing this burden, to Washington Headquarters Services, Directorate for Information Operations and Reports, 1215 Jefferson Davis Highway, Suite 1204, Arlington VA 22202-4302. Respondents should be aware that notwithstanding any other provision of law, no person shall be subject to a penalty for failing to comply with a collection of information if it does not display a currently valid OMB control number.

1. REPORT DATE <b>05 APR 1984</b>	2. REPORT TYPE <b>Technical Memo</b>	3. DATES COVERED <b>05-04-1984 to 05-04-1984</b>	
4. TITLE AND SUBTITLE <b>The Production and Utilization of a Synthetic Sampling Frequency as Applied to Quadrature Demodulation for Envelope Detection</b>		5a. CONTRACT NUMBER	
		5b. GRANT NUMBER	
		5c. PROGRAM ELEMENT NUMBER <b>62759N</b>	
6. AUTHOR(S) <b>Joseph Monti</b>		5d. PROJECT NUMBER <b>C65009</b>	
		5e. TASK NUMBER	
		5f. WORK UNIT NUMBER	
7. PERFORMING ORGANIZATION NAME(S) AND ADDRESS(ES) <b>Naval Underwater Systems Center, New London, CT, 06320</b>		8. PERFORMING ORGANIZATION REPORT NUMBER <b>TM 841026</b>	
9. SPONSORING/MONITORING AGENCY NAME(S) AND ADDRESS(ES) <b>Naval Sea Systems Command</b>		10. SPONSOR/MONITOR'S ACRONYM(S) <b>NAVSEA</b>	
		11. SPONSOR/MONITOR'S REPORT NUMBER(S)	
12. DISTRIBUTION/AVAILABILITY STATEMENT <b>Approved for public release; distribution unlimited</b>			
13. SUPPLEMENTARY NOTES <b>NUWC2015</b>			
14. ABSTRACT <b>A synthetic sampling frequency has been developed utilizing a 25 kHz SERVO-channel CW signal and a predetermined frequency of choice to achieve the proper sampling frequency for quadrature demodulation. The required synthetic sampling frequency examined here is 4f and is compared with the actual pre-recorded 4f. Very favorable results are shown for signals which were envelope detected utilizing quadrature demodulation methods. This technique may be applied to produce any sampling frequency of choice, and can thereby prove to be a valuable signal processing tool.</b>			
15. SUBJECT TERMS <b>signal processing; Shallow Water ASW Acoustics; SF 59-552B</b>			
16. SECURITY CLASSIFICATION OF:			17. LIMITATION OF ABSTRACT <b>Same as Report (SAR)</b>
a. REPORT <b>unclassified</b>	b. ABSTRACT <b>unclassified</b>	c. THIS PAGE <b>unclassified</b>	
			18. NUMBER OF PAGES <b>30</b>
19a. NAME OF RESPONSIBLE PERSON			

PREFACE

This report was prepared under NUSC Project No. C65009, Shallow Water ASW Acoustics (U), Principal Investigator, Paul D. Koenigs (Code 3331). The sponsoring activity is the Naval Sea Systems Command, C. D. Smith (NAVSEA 63R) Director. Funding is provided under Program Element No. 62759N, D. Porter, (NAVSEA 63R1) Manager. This effort was performed under Subproject SF 59-552B, Dr. W. B. Moseley, responsible individual.

*cy 001*

NAVAL UNDERWATER SYSTEMS CENTER  
NEW LONDON LABORATORY  
NEW LONDON, CT 06320

Technical Memorandum

The Production and Utilization of a Synthetic  
Sampling Frequency as Applied to Quadrature  
Demodulation for Envelope Detection

Date: 5 April 1984

Prepared by:

*Joseph M. Monti*

Joseph M. Monti  
General Engineer, 3331

DISTRIBUTION STATEMENT "A"  
Approved for public release  
Distribution unlimited

PREFACE

This report was prepared under NUSC Project No. C65009, Shallow Water ASW Acoustics (U), Principal Investigator, Paul D. Koenigs (Code 3331). The sponsoring activity is the Naval Sea Systems Command, C. D. Smith (NAVSEA 63R) Director. Funding is provided under Program Element No. 62759N, D. Porter, (NAVSEA 63R1) Manager. This effort was performed under Subproject SF 59-552B, Dr. W. B. Moseley, responsible individual.

## ABSTRACT

A synthetic sampling frequency has been developed utilizing a 25 kHz SERVO-channel CW signal and a predetermined frequency of choice to achieve the proper sampling frequency for quadrature demodulation. The required synthetic sampling frequency examined here is  $4f_0$  and is compared with the actual pre-recorded  $4f_0$ . Very favorable results are shown for signals which were envelope detected utilizing quadrature demodulation methods. This technique may be applied to produce any sampling frequency of choice, and can thereby prove to be a valuable signal processing tool.

## INTRODUCTION

In the process of A/D conversion, one is always faced with the task of choosing the appropriate sampling frequency ( $f_s$ ) so that the digital form of the data is unbiased and truly reflects its analog counterpart. This is all so apparent when applying the techniques of quadrature demodulation to the envelope detection of a signal. With one technique of quadrature demodulation, consecutive samples taken exactly  $90^\circ$  apart at a sampling frequency of  $4f_0$  (four times the center frequency), are needed for the demodulation to be accomplished correctly. A more detailed explanation of this quadrature demodulation technique is given in Appendix I.

During the A/D conversion process of some recently acquired analog tapes from the NOREX '83 experiment, a problem arose when the tape recorded version of the  $4f_0$  was missing from some of the analog tapes. The engineering task was to develop a synthetic  $4f_0$  which had the same attributes as the real  $4f_0$  and could be used to successfully quadrature demodulate the data signals. As will be shown, there is a relatively straightforward solution to the task as long as a CW signal has been recorded which preserves the phase errors introduced by tape speed variation.

The hardware set-up, and subsequent testing of the synthetic  $4f_0$  against a real  $4f_0$  is presented in the sections which follow.

## HARDWARE SET-UP

The hardware set-up for the generation of the synthetic  $4f_0$  is shown in Figure 1. For this case, the 25 kHz SERVO-frequency on an analog tape is band-pass filtered and fed into a multiplier box. A predetermined mixing frequency of constant phase is generated by a frequency synthesizer and inserted into the mixer [see Appendix II, case II]. The output of the multiplier consists of two frequencies, a sum and a difference frequency. The output of the multiplier is then bandpass filtered for the desired sum or difference frequency.

For example, if one is interested in a quadrature demodulated signal with a center frequency ( $f_0$ ) of 20 kHz, a sampling frequency ( $f_s$ ) of  $4f_0$ , or 80 kHz is needed in real time. If this is done at  $1/8$ th real time, as was the case with the NOREX '83 20 kHz data, a 10 kHz sampling frequency is actually required. In this case, the 25 kHz SERVO-frequency from tape is at 3.125 kHz and the predetermined mixing frequency is 6.875 kHz. The result is a sum frequency of 10.0 kHz and a difference frequency of 3.75 kHz. This complex signal is then bandpass filtered at 10 kHz to achieve the desired  $4f_0$ .

The synthetic  $4f_0$  was then compared with a real  $4f_0$ , which was recorded on tape, to determine the validity of the approach, as illustrated in Figure 2.

RESULTS

A comparison of the real  $4f_0$  and the synthetic  $4f_0$  was done for a signal with a center frequency of 20 kHz. For the case examined, the same processing, quadrature demodulation, and A/D conversion procedures were used on the same data set of CW pulses, the only difference being the type of  $4f_0$  sampling frequency used in the A/D conversion process. In one case the real  $4f_0$  from tape was used [see Appendix II, case I], and in the second case a synthetic  $4f_0$  was used as described in Appendix II, case II. The comparison is made on an individual pulse basis and also on the ensemble average of twenty-five pulses.

In Figures 3a and 3b, the level versus time of the signal envelope is presented for comparative purposes, for the real and synthetic  $4f_0$  sampling frequencies. It is readily apparent that on a pulse for pulse and ensemble average basis, there is no observable difference in the pulse or signal envelopes. Due to A/D noise, differences are seen in noise values as expected [see Appendix III].

Since the area of interest is the signal envelope, Figure 4 represents an enlarged version of a representative envelope which is presented. Here, a well defined smooth envelope is seen for the real  $4f_0$  and synthetic  $4f_0$ . If the quadrature demodulation technique was not being accomplished properly, a decrease in level or a modulation component would be seen on top of the envelope [see Figures A1 and A3]. Since neither is occurring, we can conclude the quadrature demodulation technique is being implemented properly with a synthetically generated  $4f_0$ .

With the magnitude portions of the real and synthetic  $4f_0$  in excellent agreement, the final aspect to make the comparison complete is the phase of the signal. Figures 5a and 5b present a pulse to pulse comparison between the two types of sampling frequencies for four different pulses. Once again slight differences are seen in the phase of the noise floor, but the phase components of the signal are in excellent agreement.

With excellent agreement in magnitude and phase, a check was done on an ensemble of pulses. Figure 6 represents this comparison and once again excellent agreement is seen between the real  $4f_0$  and synthetic  $4f_0$  with only 0.1 dB difference in the mean values.

With the completion of this last comparison a summary is now presented in Table 1. Here, very good agreement is seen in the first order statistics between the real and synthetic  $4f_0$  sampling frequencies. The largest differences in this table are once again associated with the noise floor.

SUMMARY AND CONCLUSIONS

A  $4f_0$  sampling frequency was required in order to implement a quadrature demodulation technique. There are however, no restrictions which preclude extending the results of this work to other sampling frequencies.

After some theoretical considerations and experimentation, a synthetic  $4f_0$  was produced which did possess phase and frequency characteristics similar to the real  $4f_0$ . This synthetic  $4f_0$  was produced by multiplying a 25 kHz CW tape recorded SERVO signal and a predetermined mixing frequency. The 25 kHz CW SERVO signal from tape had the same time dependent phase as the signal of interest, and the predetermined frequency CW from the frequency synthesizer had a time independent phase. The multiplier output was subsequently filtered to discriminate between the sum and difference sampling frequency.

A set of data were processed using a recorded (real  $4f_0$ ) and synthesized (synthetic  $4f_0$ ) sampling frequency to form comparative test cases. The results of the comparison between amplitude, phase, arrival time, and first order statistics of the signal envelope were excellent.

Since the results between the synthetic  $4f_0$  and the real  $4f_0$  are in such good agreement, it is my opinion the synthetic  $4f_0$  process can indeed be used for the A/D conversion process.

If this synthetic sampling frequency technique is used, considerable thought should be given to selecting the CW SERVO signal which will be recorded. This is a necessity because when the CW SERVO signal is subsequently multiplied and filtered to obtain the synthetic  $4f_0$ , the sum and difference frequency are far enough apart so that a filtering problem is not encountered in trying to segregate the sum and difference frequency.

If this technique is to be implemented without unnecessary problems, possible drawbacks of the technique should be highlighted. The first, and most important drawback is the choosing of a proper CW SERVO signal on tape so as not to impose filtering problems when this signal is multiplied with the mixing frequency. Another drawback is that the actual production of a synthetic sampling frequency will entail utilizing more equipment than required if the desired sampling frequency were recorded.

In closing it should be noted that the author highly recommends this technique of producing a synthetic sampling frequency for use when the optimum sampling frequency has not been pre-recorded.

APPENDIX I

OVERVIEW OF A QUADRATURE DEMODULATION TECHNIQUE

Let  $x_i(t)$  be a signal from hydrophone  $i$  and  $y_i(t)$  be the  $90^\circ$  phase shifted signal from hydrophone  $i$ .

The time sampled signals can be represented as;  $x_{im}(m\Delta t)$ ,  $y_{im}(m\Delta t)$  where  $m$  is the digital sample point and  $\Delta t$  is the inverse of the sampling frequency.

The envelope of the signal from the  $i^{\text{th}}$  hydrophone can be obtained utilizing the following equation;

$$A_{im} = [x_{im}^2 + y_{im}^2]^{1/2} \quad (1)$$

As an example, let

$$x_i(t) = B\sin(\omega t) \quad (2)$$

$$y_i(t) = B\sin(\omega t + 90^\circ) = B\cos(\omega t) \quad (3)$$

where  $B$  is constant.

The envelope of the signal  $[|S_i(t)|]$  can then be obtained as follows:

$$|S_i(t)| = [x_i^2(t) + y_i^2(t)]^{1/2} \quad (4)$$

$$|S_i(t)| = [B^2(\sin^2\omega t + \cos^2\omega t)]^{1/2} = B \quad (5)$$

Similarly, the phase of the envelope may be defined as:

$$\phi_i = \tan^{-1}[x_i/y_i] \quad (6)$$

We see there is no reduction in the amplitude of the original signal when the signal is envelope detected using this quadrature demodulation technique.

We can achieve this result if the sampling frequency chosen fits the criteria below:

$$\frac{(\text{center frequency } (f_0)) (360^\circ)}{(\text{sampling frequency } (f_s))} = 90^\circ \quad (7)$$

For this to be true the sampling frequency  $f_s$  must equal  $4f_0$  (four times the center frequency).

NUSC TM 841026

Variations from  $4f_0$  will cause an error in the true amplitude level of the envelope as shown in the example below.

Let,

$$\begin{aligned} f_0 &= 20 \text{ kHz} \\ f_s &= 81 \text{ kHz} \end{aligned}$$

then from Eq. 7;  $\frac{(20.0 \text{ kHz}) (360^\circ)}{(81.0 \text{ kHz})} = 88.9$

A  $88.9^\circ$  phase shift is seen thus the identify transformation of (3) cannot be employed and the term in parenthesis in (5) is not identical to 1. Therefore, an amplitude error in the envelope is introduced when samples not spaced  $90^\circ$  apart are used.

APPENDIX II

Phase Relations Between Signal and Sampling Frequency

- $f_0$  - center frequency of interest
- $x_i(t)$  - signal from a hydrophone i
- $y_i(t)$  - signal delayed by 90° from a hydrophone i
- $f_s$  - sampling frequency =  $4f_0$
- $\phi$  - phase

CASE I - Hydrophone signal and correct sampling frequency on tape.

$$x_i(t) = A \sin[w_1 t + \phi_1(t)] \tag{1}$$

$$f_s(t) = B \sin[4w_1 t + \phi_1(t)] \tag{2}$$

where the quantity in brackets [ ] will be called  $\theta$ . The instantaneous value of  $\theta$  for the above two expressions is

$$\dot{\theta}[x_i(t)] = w_1 + \dot{\phi}_1 \tag{3}$$

$$\dot{\theta}[f_s(t)] = 4w_1 + \dot{\phi}_1 \tag{4}$$

where the dot represents the time derivative. It is apparent the phase terms of the signals exhibit the same time dependence,  $\dot{\phi}_1$  from (3) equals  $\dot{\phi}_1$  from (4), therefore quadrature demodulation can be accomplished successfully.

CASE II - Signal and CW SERVO-frequency on tape.

The sampling frequency is achieved by multiplying the CW SERVO-frequency by a properly predetermined frequency from a frequency synthesizer the phase of which is time independent. The phase term from any signal on tape is time dependent because of tape speed variation.

Here, the multiplier output is

$$\underbrace{\sin(w_2 t + \phi_2(t))}_{\text{CW SERVO frequency}} \underbrace{\sin(w_3 t + \phi_3)}_{\text{frequency synthesizer frequency}}$$

and the result obtained is

$$\begin{aligned} & 1/2[\cos(w_2 t + \phi_2(t) - w_3 t - \phi_3) - \cos(w_2 t + \phi_2(t) + w_3 t + \phi_3)] \\ & = 1/2[\cos((w_2 - w_3)t + \phi_2(t) - \phi_3) - \cos((w_2 + w_3)t + \phi_2(t) + \phi_3)] \end{aligned}$$

After filtering the undesired frequency we obtain the proper  $4f_0$ . The signal and sampling frequency are now shown below.

$$x_i(t) = A \sin[w_1 t + \phi_1(t)] \quad (5)$$

$$f_s(t) = C \cos[(w_2 - w_3)t + \phi_2(t) - \phi_3] \quad (6)$$

As in case I, our concern is in the instantaneous values of the above functions of  $\theta$  (terms in brackets) for equations (5) and (6);

$$\dot{\theta}[x_i(t)] = w_1 + \dot{\phi}_1 \quad (7)$$

$$\dot{\theta}[f_s(t)] = w_2 - w_3 + \dot{\phi}_2 = w_2 - w_3 + \dot{\phi}_1 \quad (8)$$

where  $w_2 - w_3 = 4w_1$ . Therefore, equations (4) and (8) are equivalent and once again quadrature demodulation can be used successfully because the signal and instantaneous sampling frequency exhibit the same time dependence.

CASE III - Only the signal is on tape, and sampling frequency from a frequency synthesizer.

$$x_i(t) = A \sin[w_1 t + \phi_1(t)] \quad (9)$$

$$f_{s1}(t) = D \sin[4w_1 t + \phi_3] \quad \text{constant phase} \quad (10a)$$

$$f_{s2}(t) = D \sin[4w_1 t + \phi_3(t)] \quad \text{varying phase} \quad (10b)$$

Taking the instantaneous value of  $\theta$  one again reveals;

$$\dot{\theta}(x_i(t)) = w_1 + \dot{\phi}_1 \quad (11)$$

$$\dot{\theta}(f_{s1}(t)) = 4w_1 \quad (12a)$$

$$\dot{\theta}(f_{s2}(t)) = 4w_1 + \dot{\phi}_3 \quad (12b)$$

It is apparent there is a phase difference between (11) and (12a), and also between (11) and (12b). With this difference in time dependent phase between the signal and the sampling frequency, quadrature demodulation cannot be implemented successfully. The only way this could occur is if  $\dot{\phi}_3(t) = \dot{\phi}_1(t)$ . This is difficult to perceive since the signal and the sampling frequency are from two physically different pieces of equipment.

In Figures A1 through A4, the importance of the same time dependent phase between signal and sampling frequency is illustrated. In Figures A1 and A2, the differences are very evident on a pulse for pulse basis. We see a difference in level as well as modulation on top of the envelope of the signal in Figure A1. In Figures A3 and A4 we can see the differences in the ensemble averaged envelope that is not apparent in Figures A1d and A2d. Here, the presence of a modulation on top of the envelope is also seen.

## APPENDIX III

EFFECTS OF A/D NOISE

In situations of high signal-to-noise ratio, the lower limit of the A/D converter is rapidly reached and the resultant values may be subject to noise error. In this case, a 12 bit A/D was used with a dynamic range of 66dB. This means that if a data set with a high signal to noise ratio is digitized two independent times, one expects to see exact replication of the signal envelope, and some random error introduced into the low noise values due to the A/D process.

In Figure A5 the same data set is digitized twice with the real  $4f_0$ . The exact duplication of the signal envelope is seen, along with the non-exact replication of the noise floor. Figures A6 and A7 illustrate the noise level of the A/D system which is shorted at the data input and shorted at the input to the computer, respectively (see Figure 2). It becomes apparent that the noise levels due to the A/D system (filters, amplifiers, and computer) are nearly the same as the noise levels of the computer A/D.

Therefore, if noise floor level random errors are introduced when the real  $4f_0$  is utilized, they would surely be expected when the synthetic  $4f_0$  is used.

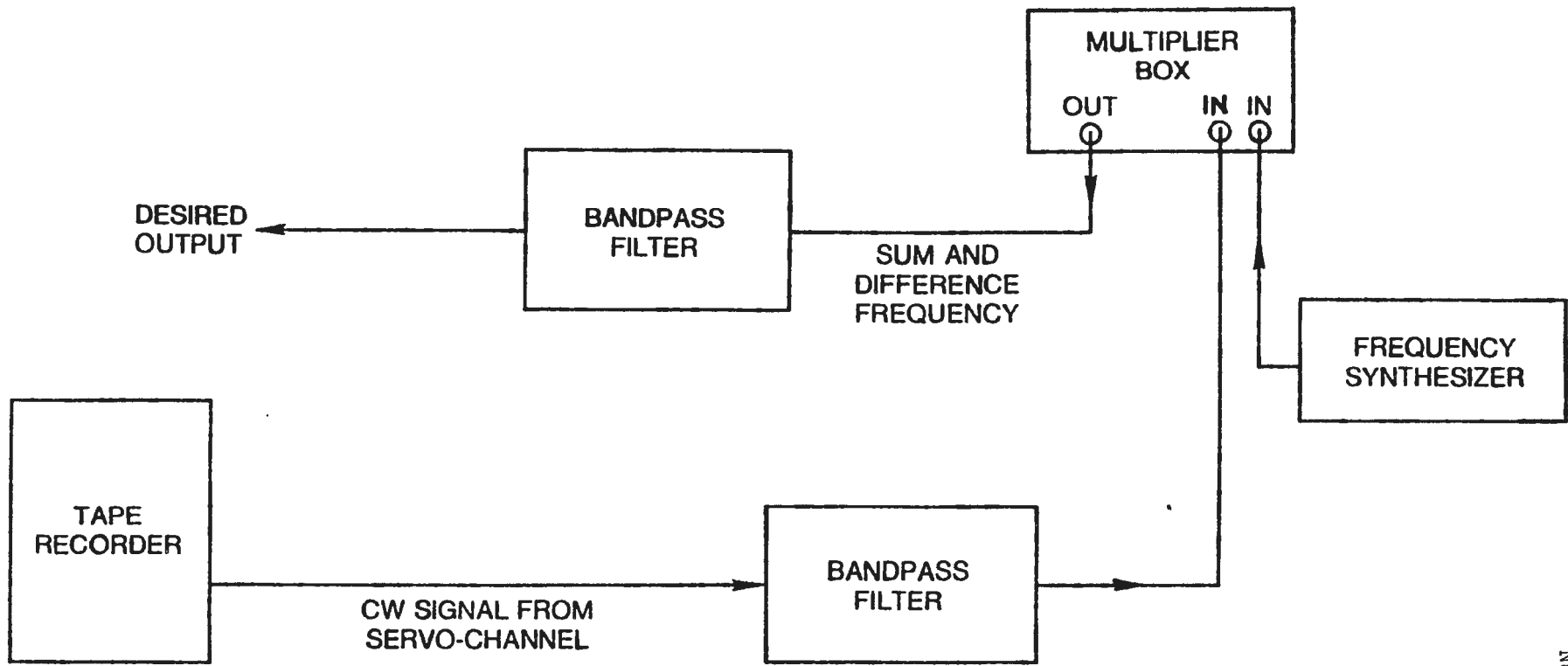

Figure 1. Basic hardware set-up for the production of a synthetic sampling frequency.

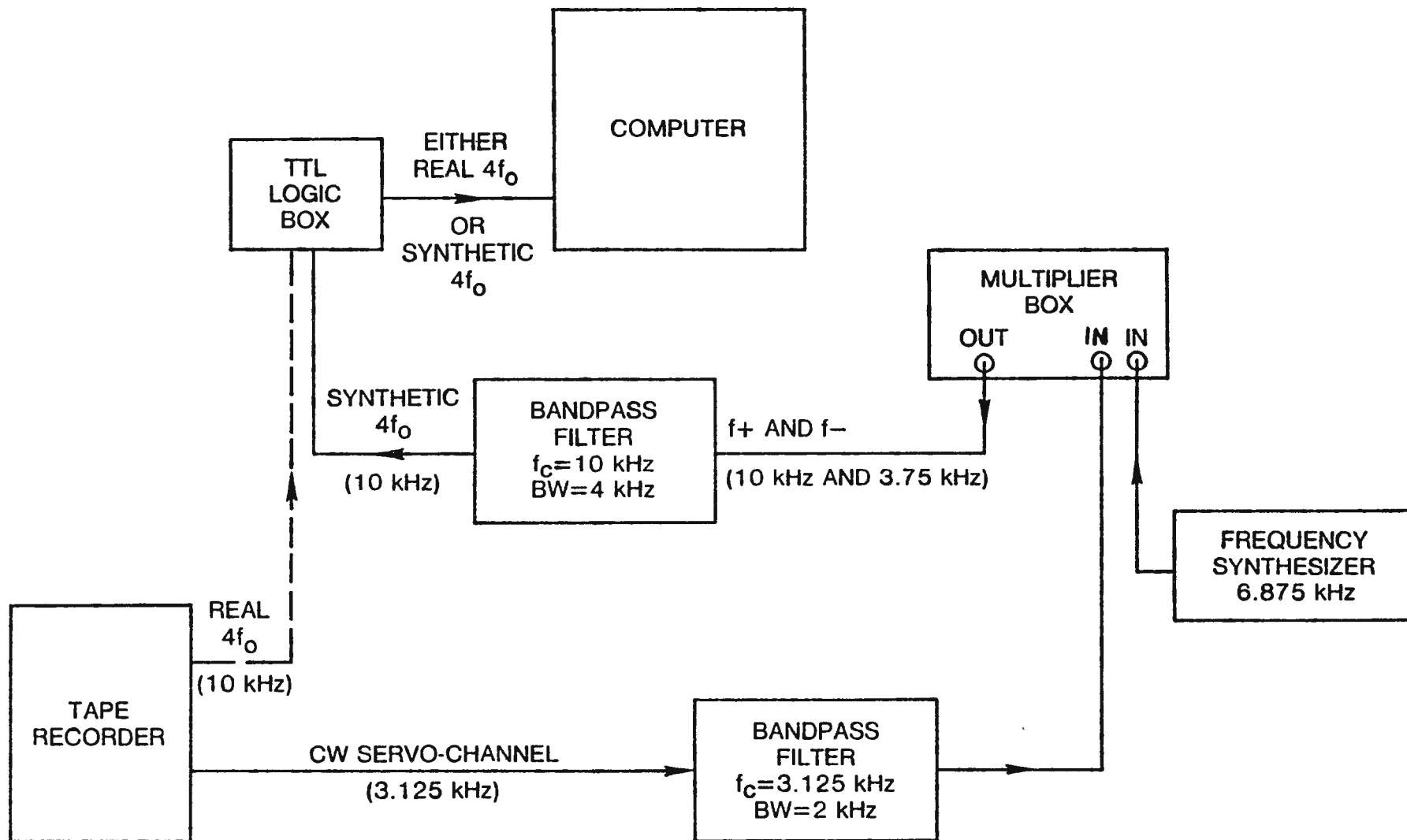

Figure 2. Production of a synthetic  $4f_0$  vs. the real  $4f_0$  for a 20 kHz center frequency (system is at 1/8 real time).

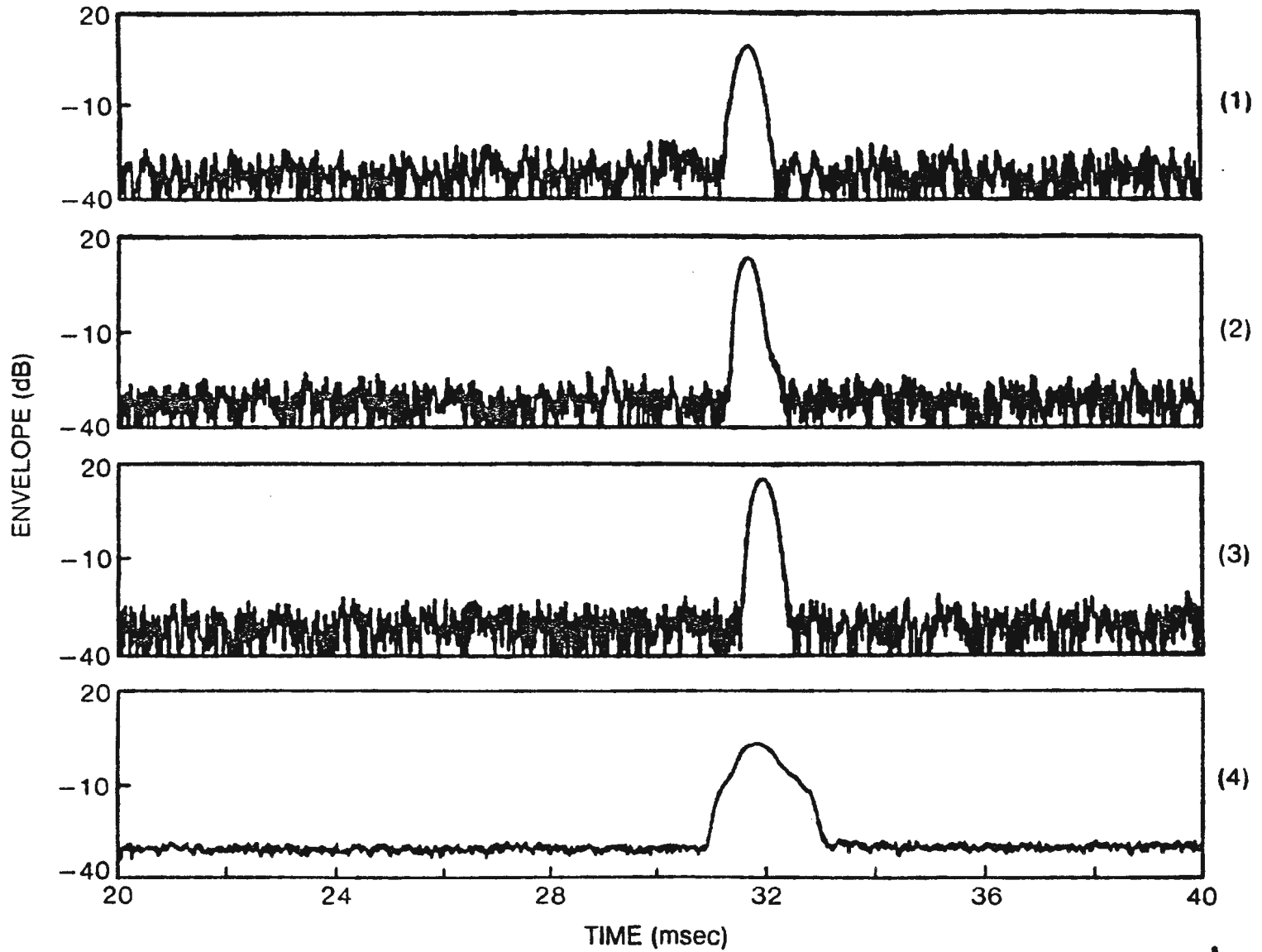

Figure 3a. Quadrature demodulated envelope of three different pulses (1,2,3) and the ensemble average of 25 pulses (4) utilizing a real  $4f_0$  sampling frequency

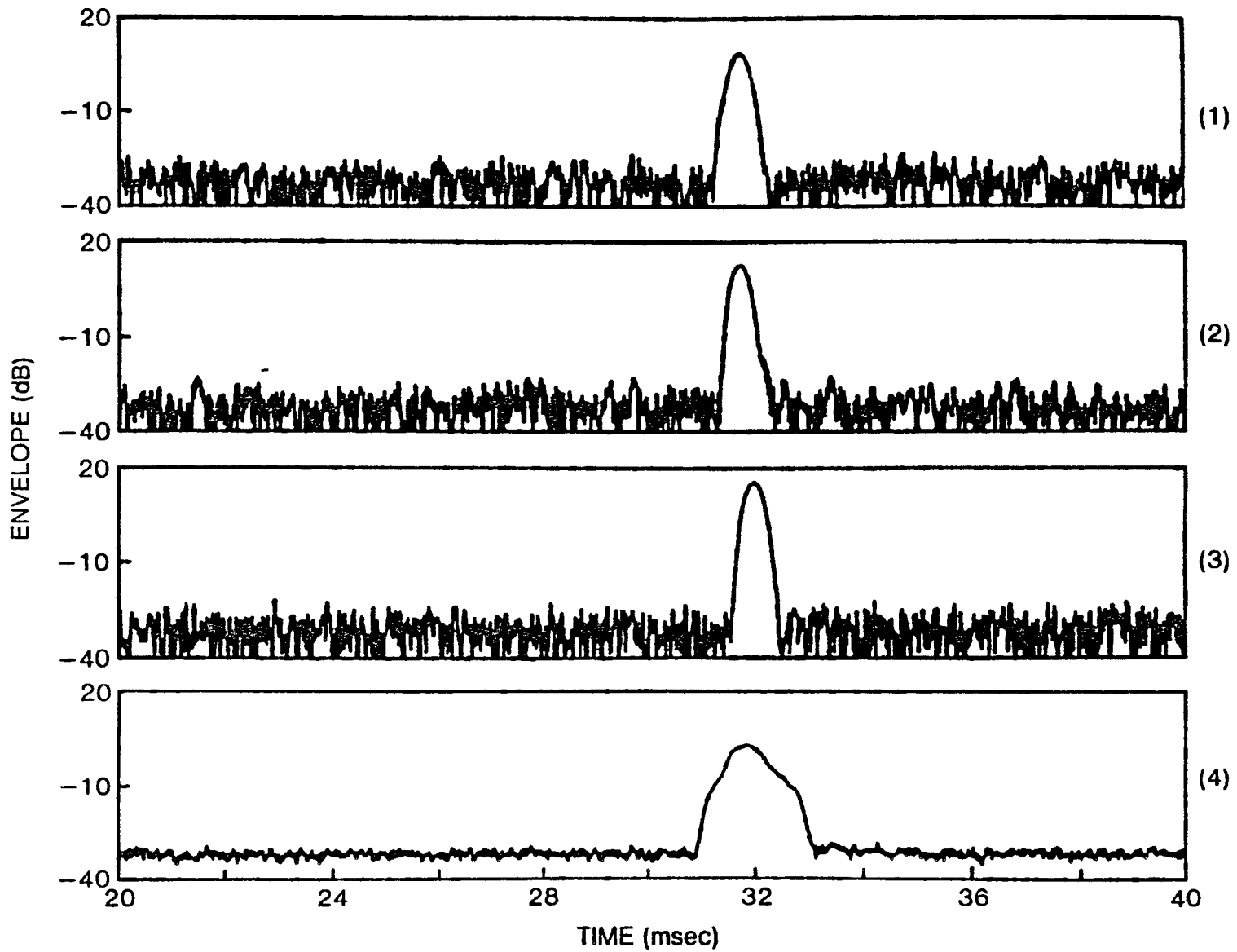

Figure 3b. Quadrature demodulated envelope of three different pulses (1,2,3) and the ensemble average of 25 pulses (4) utilizing a synthetic  $4f_0$  sampling frequency.

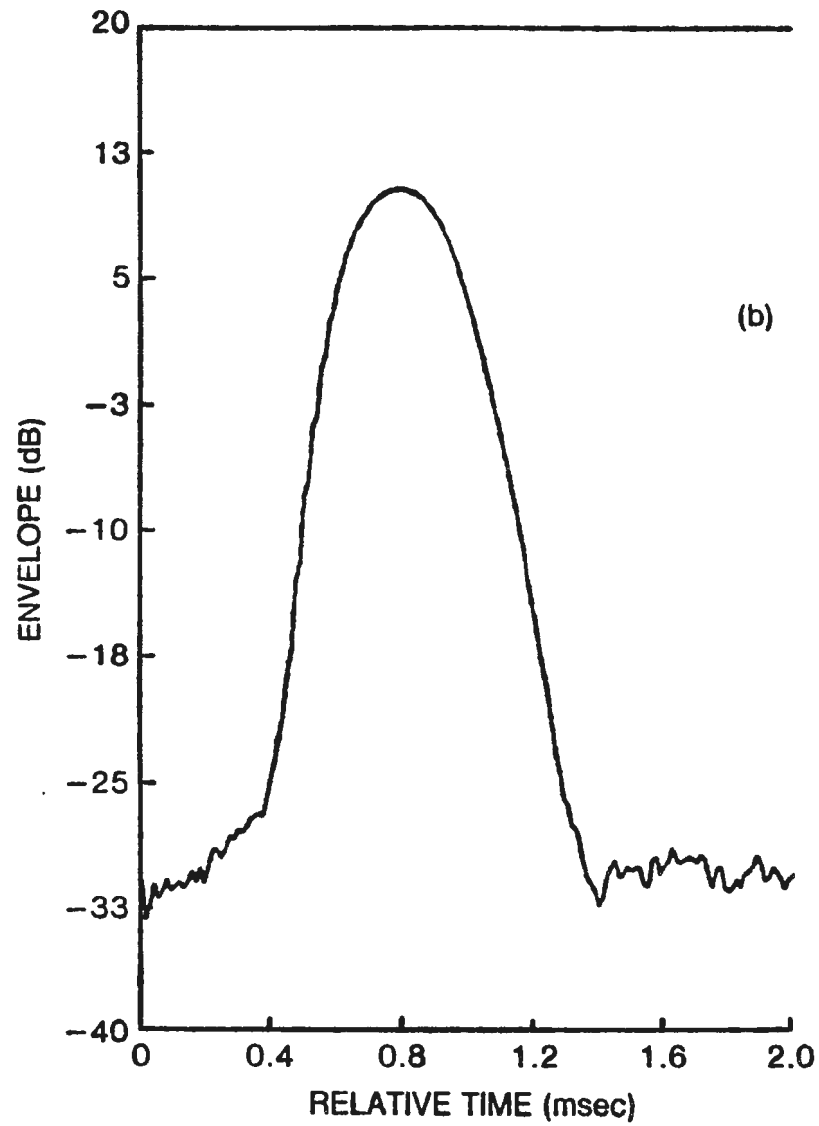
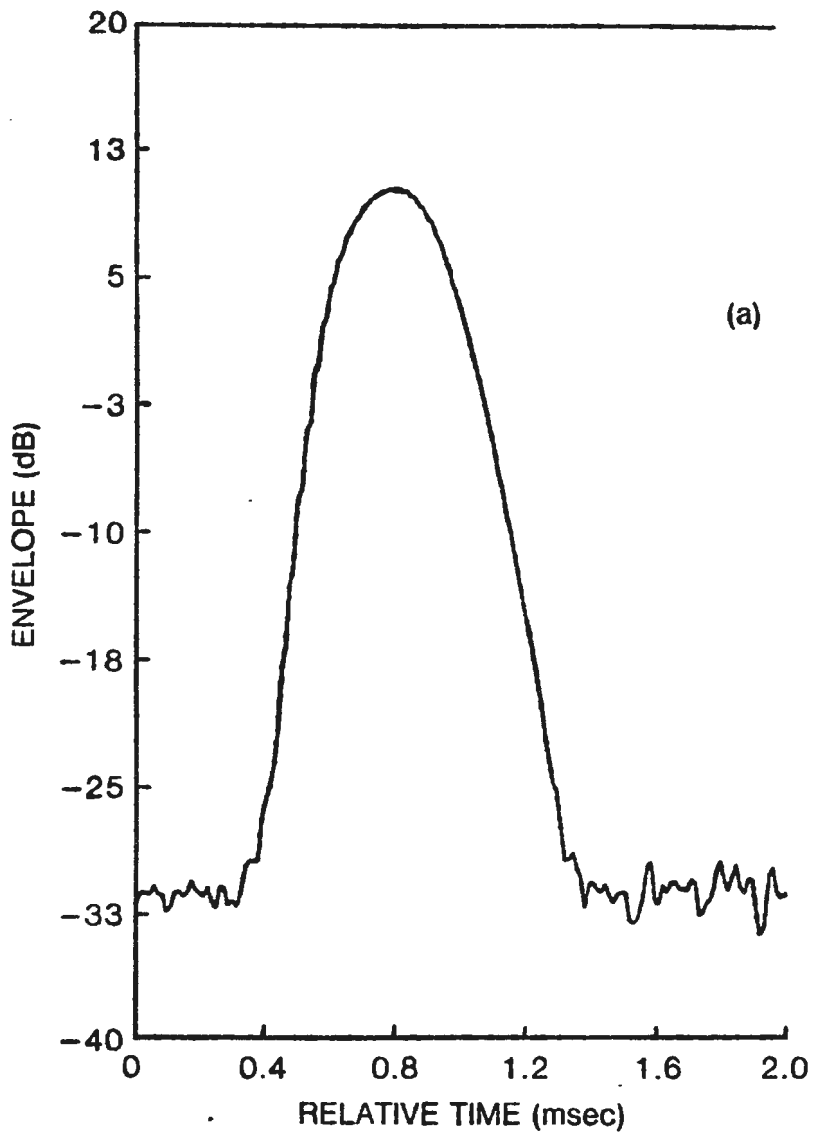

Figure 4. Enlargement of envelope of one pulse utilizing a) real  $4f_0$  and b) synthetic  $4f_0$ .

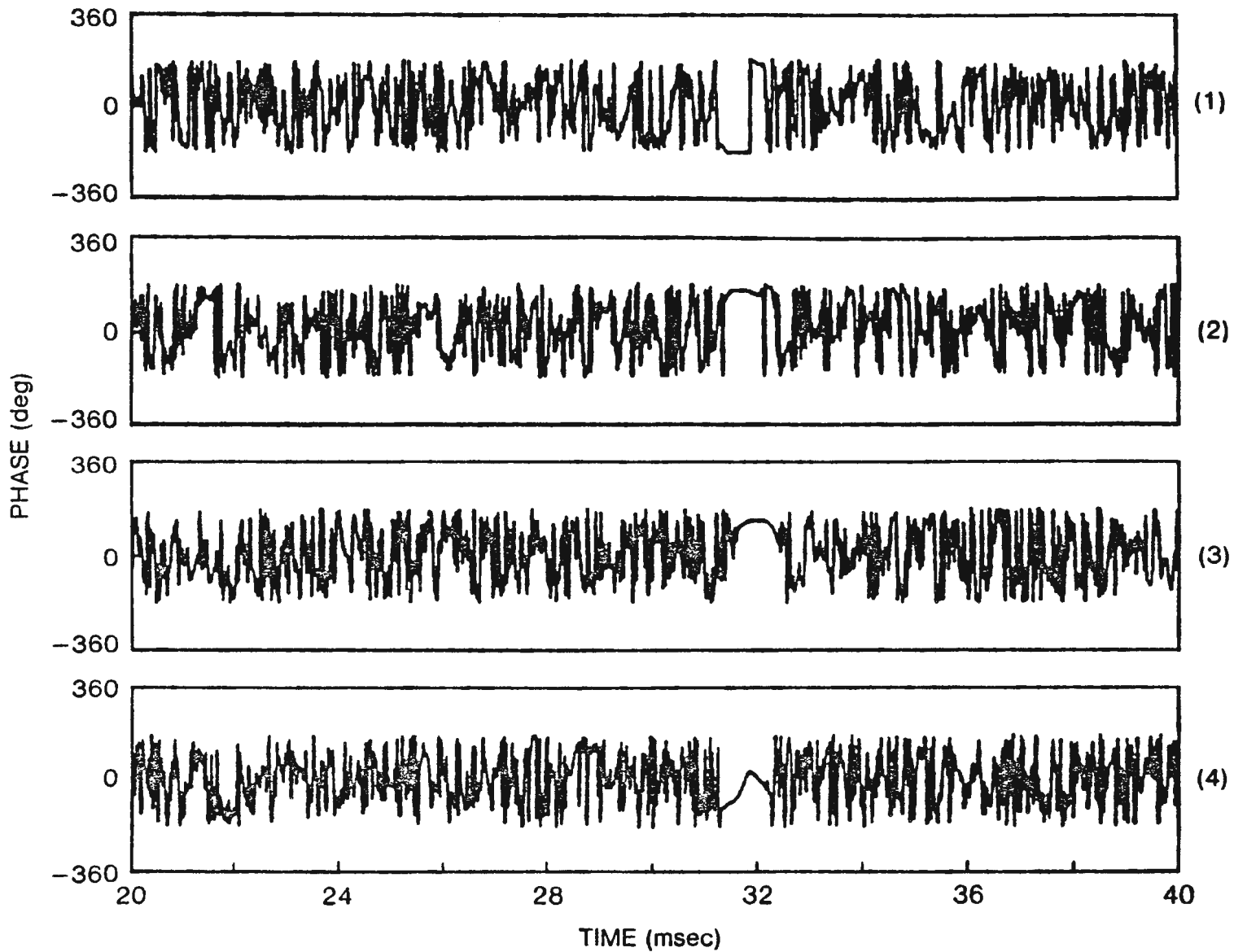

Figure 5a. Phase of 4 different pulses utilizing the real  $4f_0$  sampling frequency.

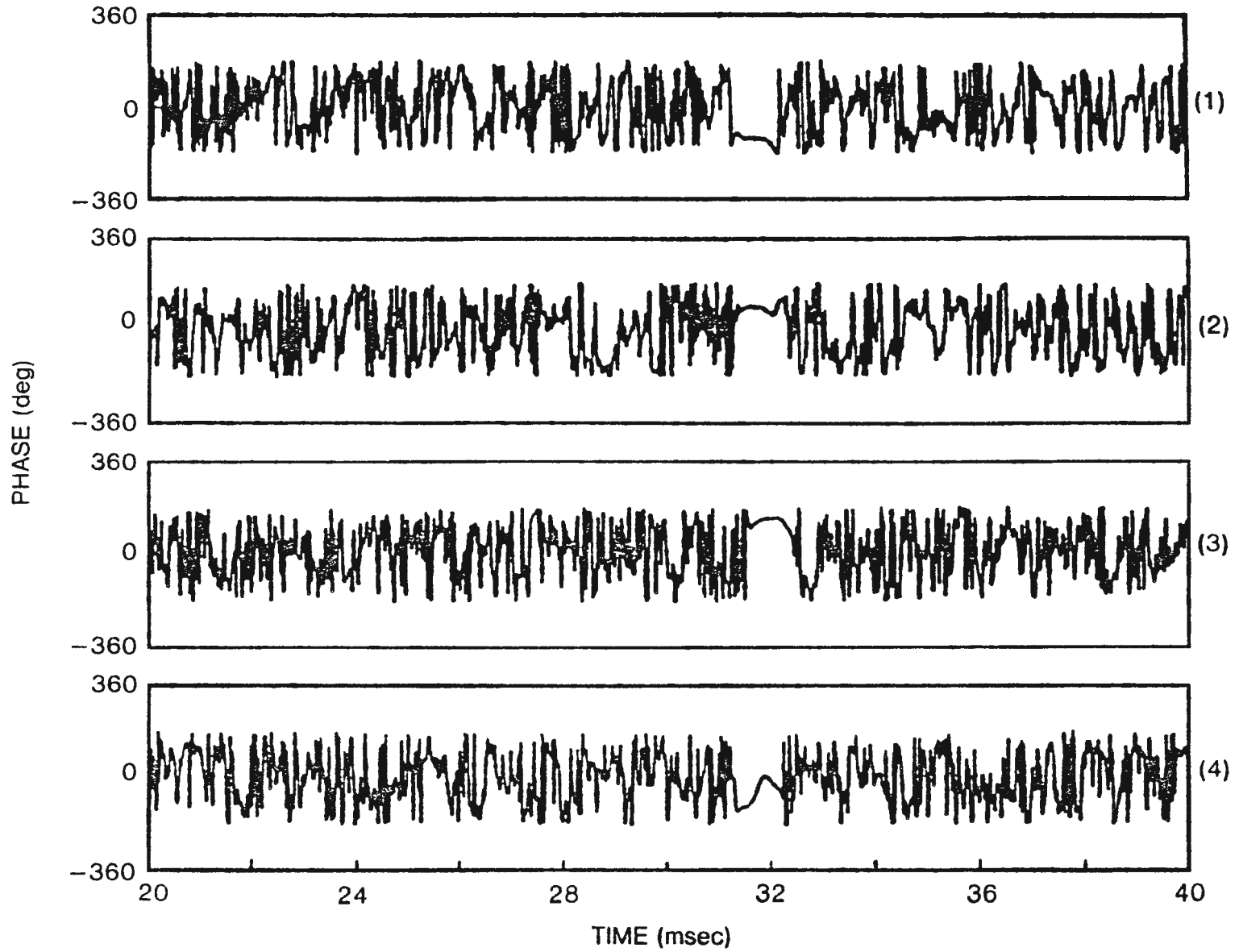
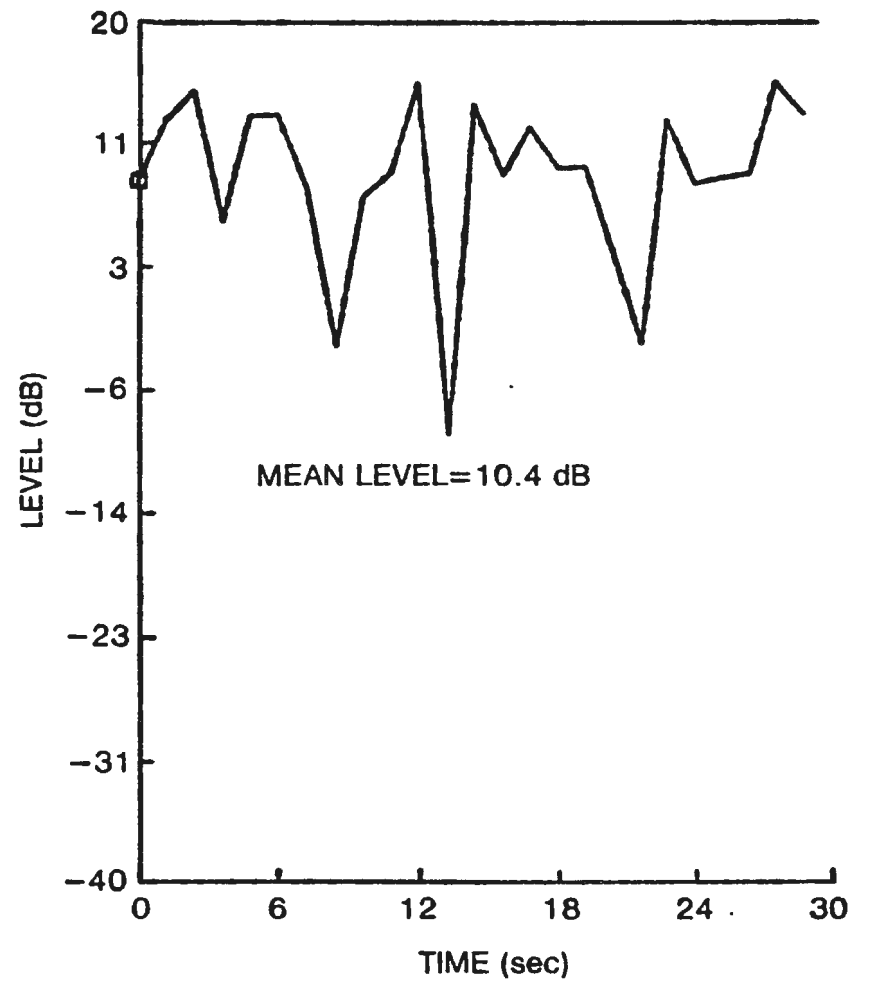
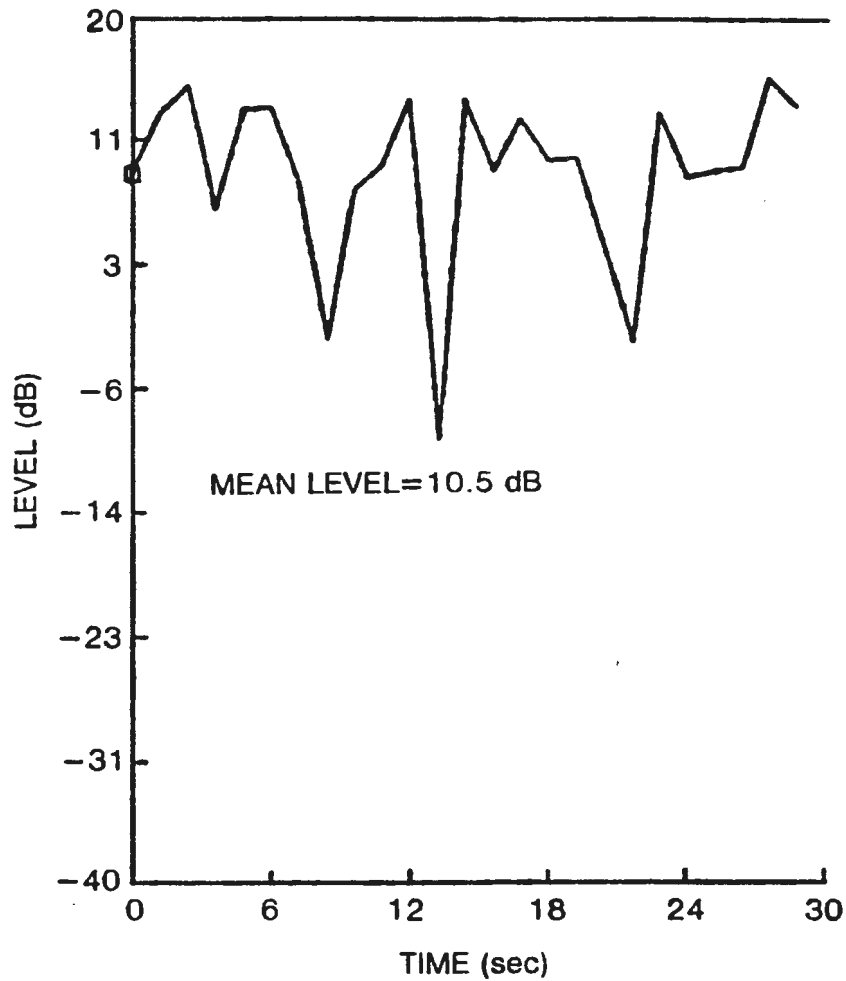

Figure 5b. Phase of 4 different pulses utilizing the synthetic  $4f_0$  sampling frequency.



(a) (b)  
 Figure 6. Peak envelope level of an ensemble of 25 pulses utilizing (a) real  $4f_0$  and (b) synthetic  $4f_0$ , for the quadrature demodulated envelope.

CRITERIA		REAL $4f_0$	SYNTHETIC $4f_0$
NOISE (dB)	MEAN	-32.42	-32.78
	STANDARD DEVIATION	1.24	1.45
	COEFFICIENT OF VARIATION	0.038	0.044
LEVEL OF SIGNAL ENVELOPE (VOLTS)	MEAN	3.38	3.32
	STANDARD DEVIATION	1.58	1.61
	COEFFICIENT OF VARIATION	0.468	0.485
TIME OF MAXIMUM SIGNAL IN THE ENVELOPE (msec)	MEAN	31.87	31.87
	STANDARD DEVIATION	0.34	0.35
	COEFFICIENT OF VARIATION	0.011	0.011

Table 1. A comparison of some first order statistics between the real  $4f_0$  and synthetic  $4f_0$  sampling frequencies.

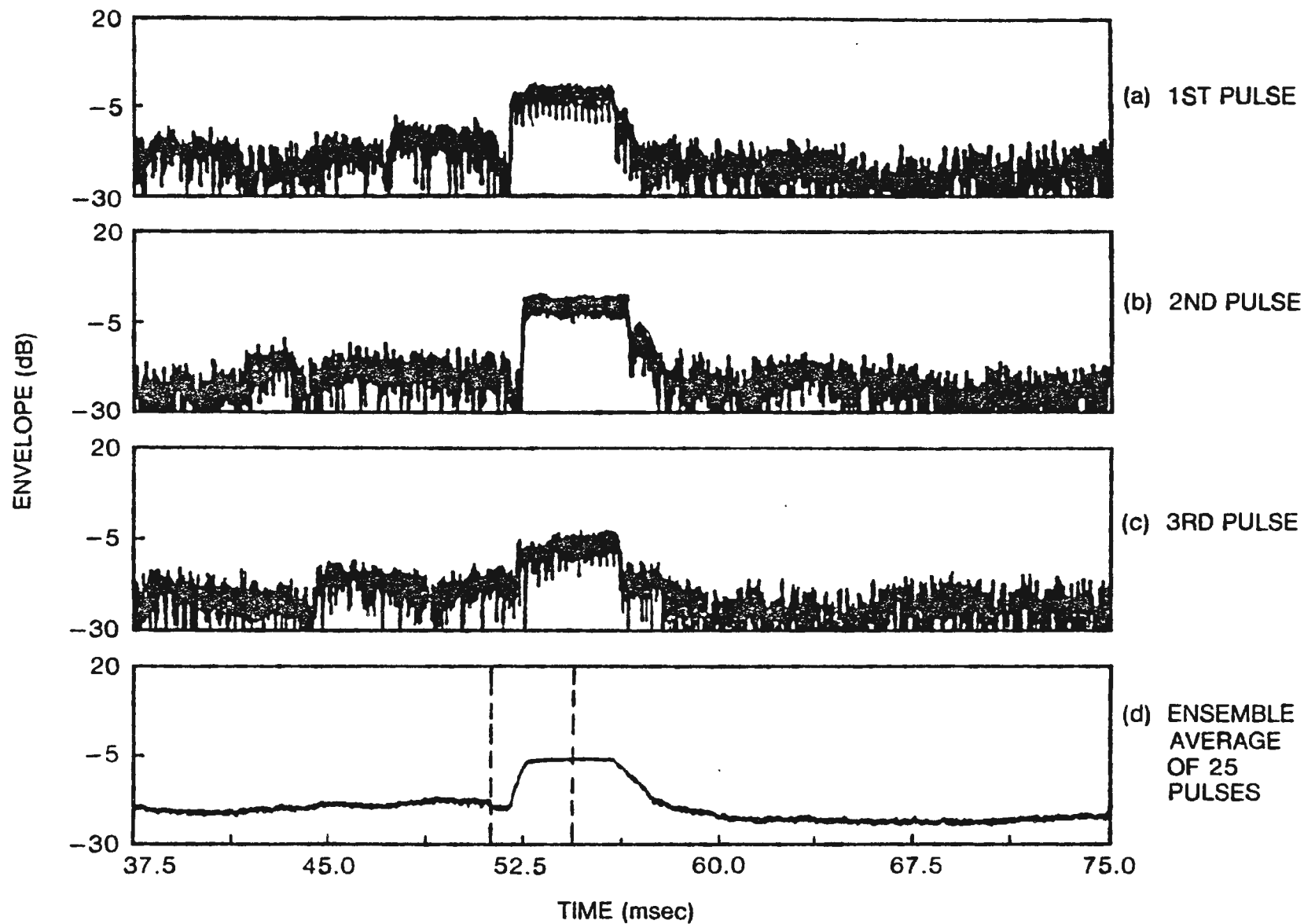

Figure A1. Signal sampled by a synthetic  $4f_0$  with time dependent phase differences between signal and sampling frequency.

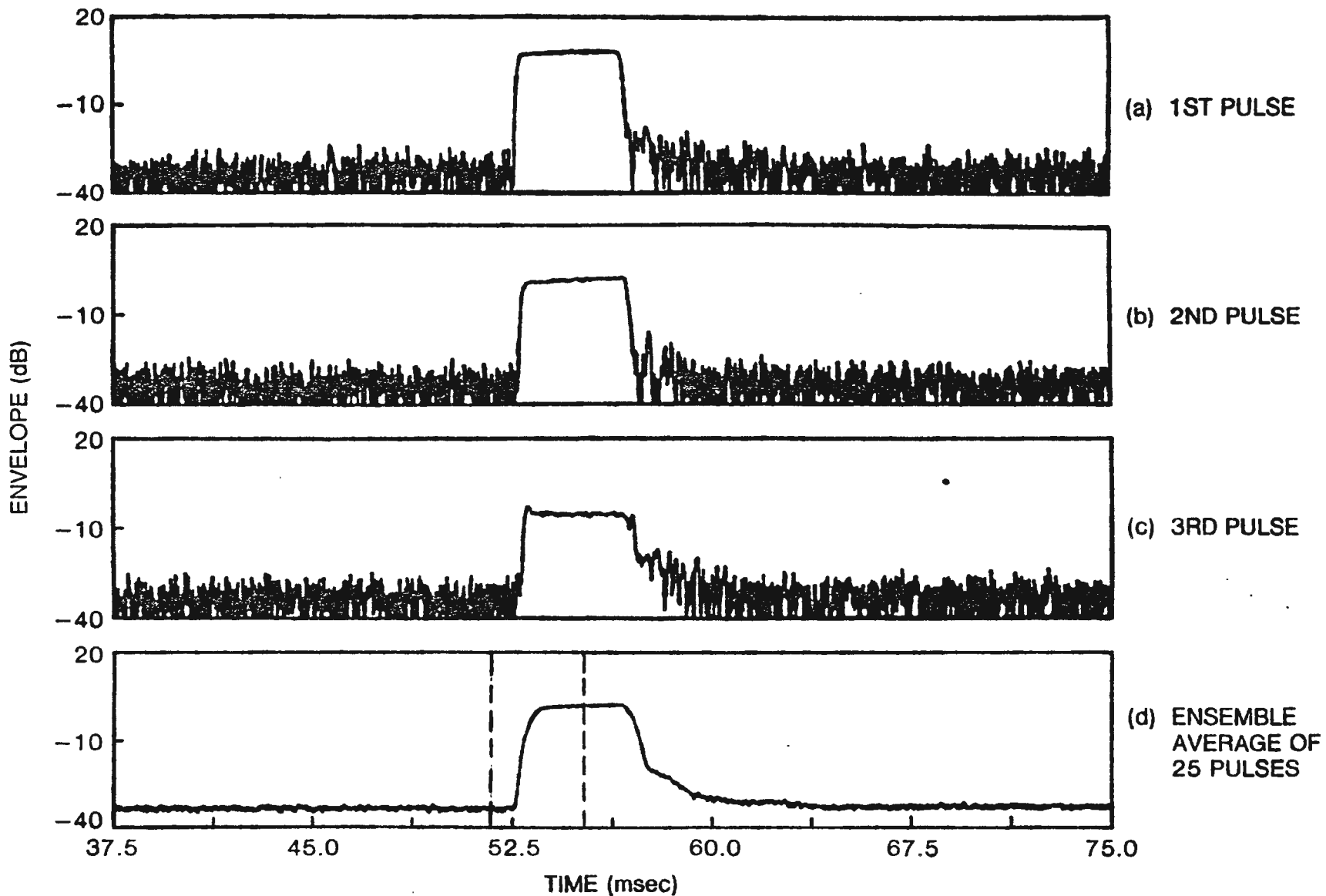

Figure A2. Signal sampled by a synthetic  $4f_0$  with no time dependent phase differences between signal and sampling frequency.

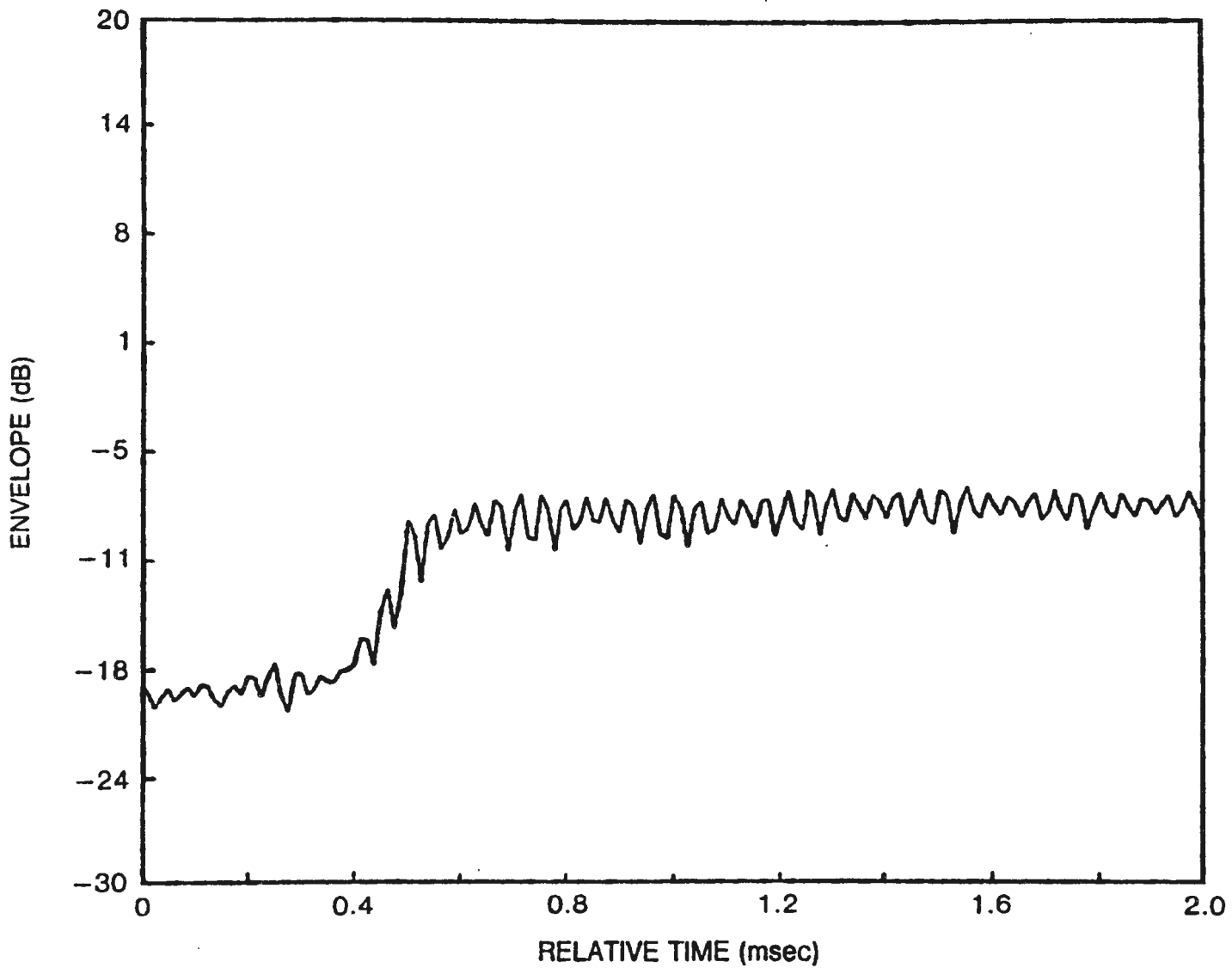

Figure A3. Enlargement of time dependent phase difference case from Figure A1-d.

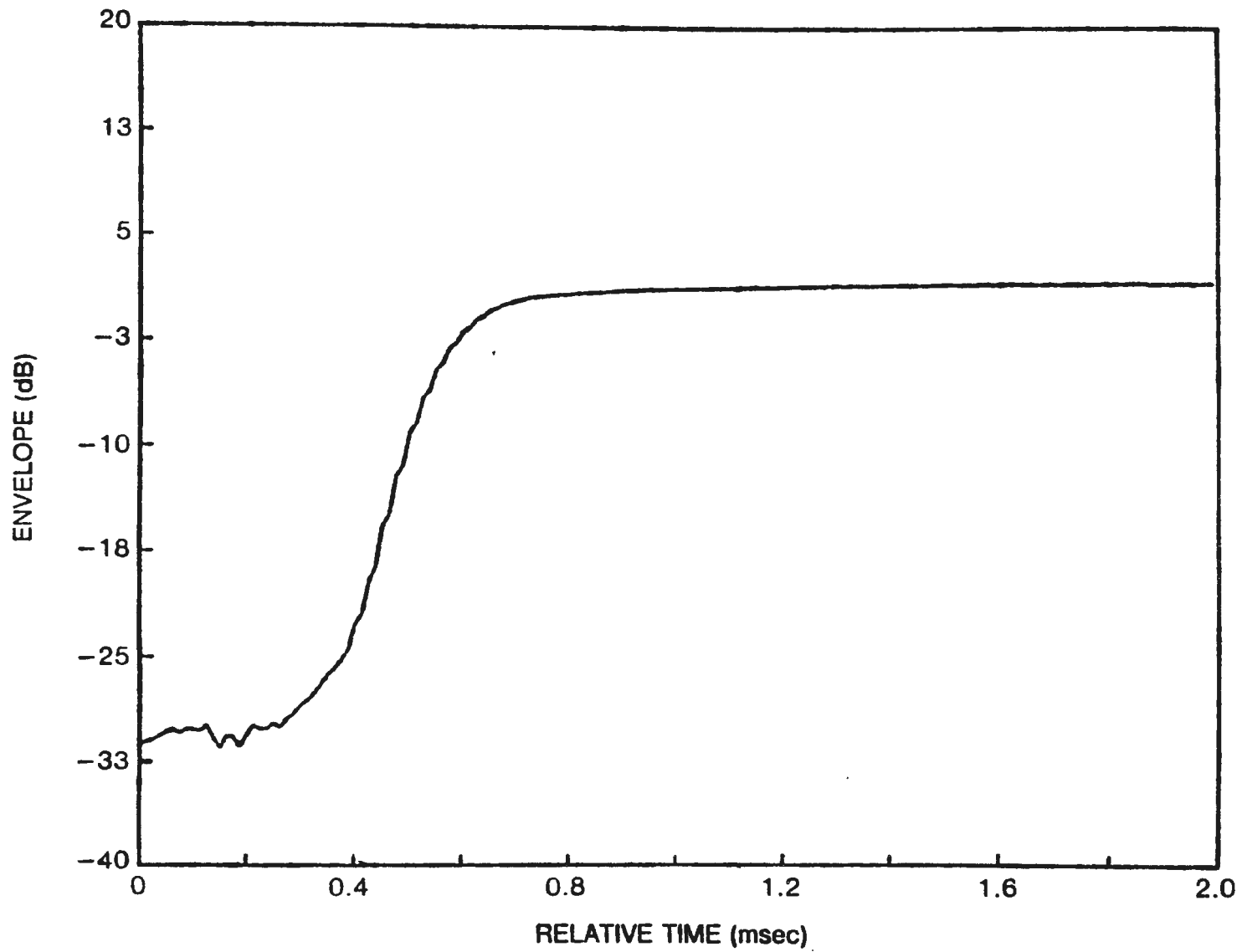

Figure A4. Enlargement of the no time dependent phase difference case in Figure A2-d.

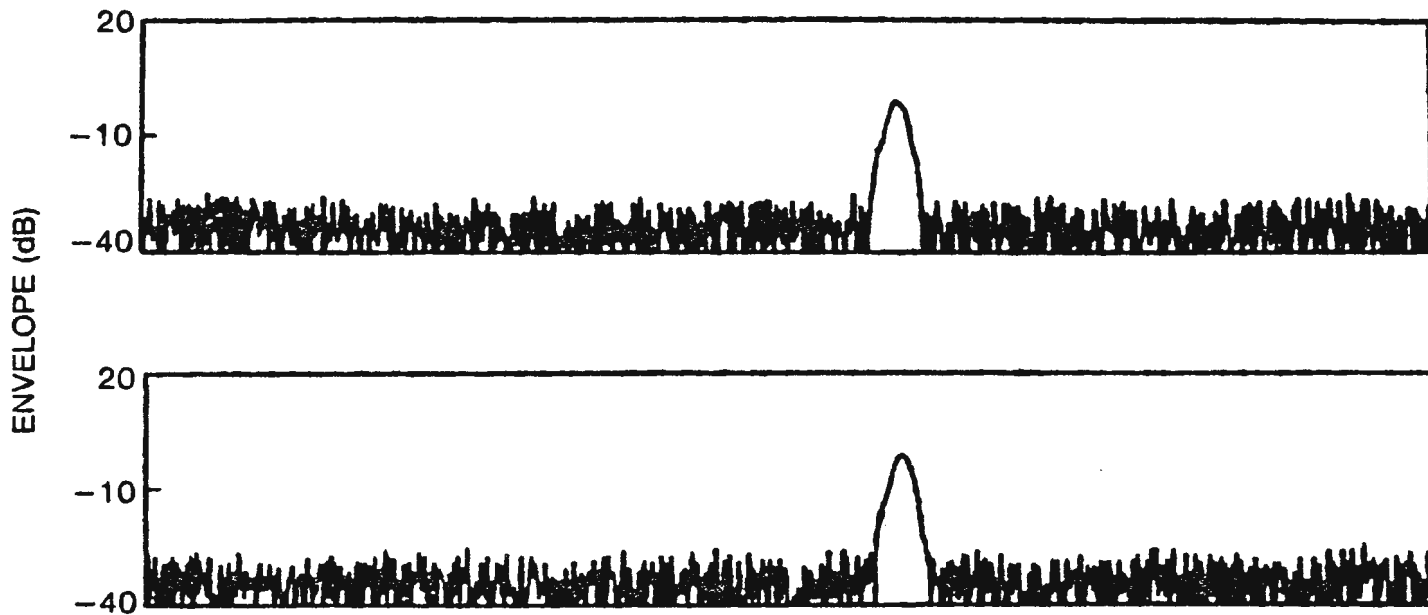

Figure A5. Two independent A/D conversions of the same piece of data utilizing the real  $4f_0$  as a sampling frequency.

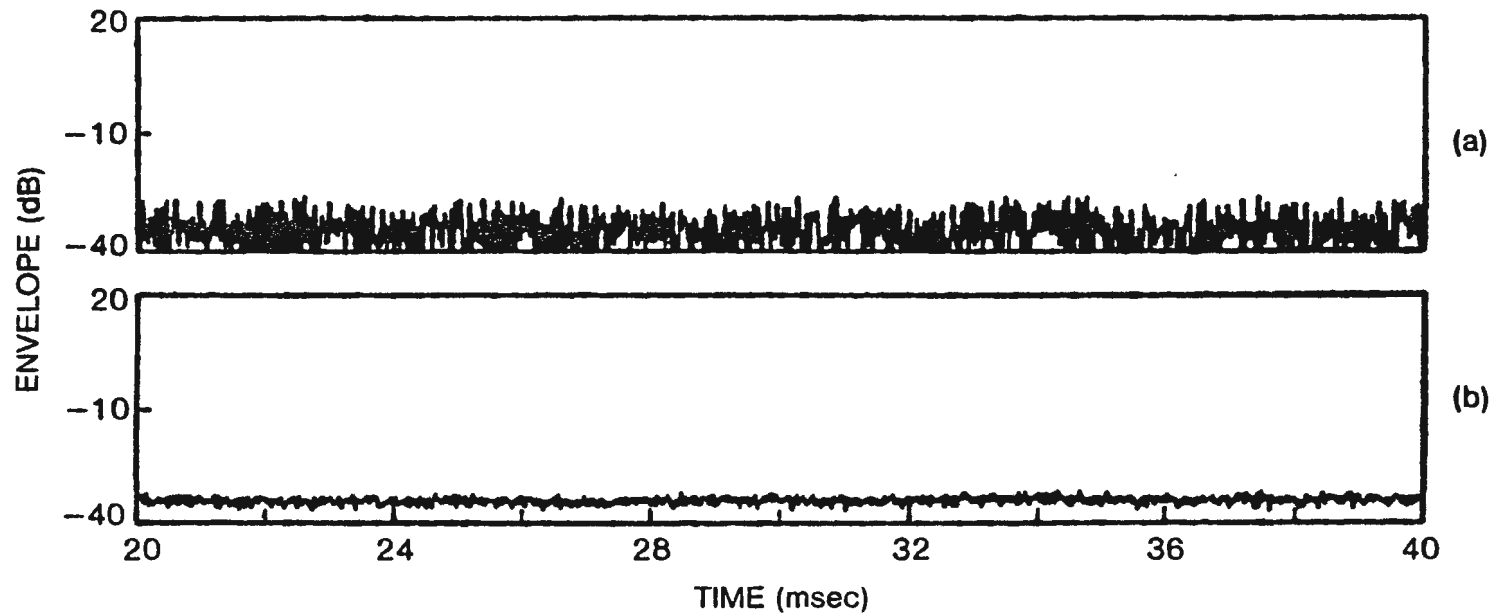

Figure A6. Noise due to A/D system which is shorted at data input for (a) one data set and (b) an ensemble average of 25 data sets.

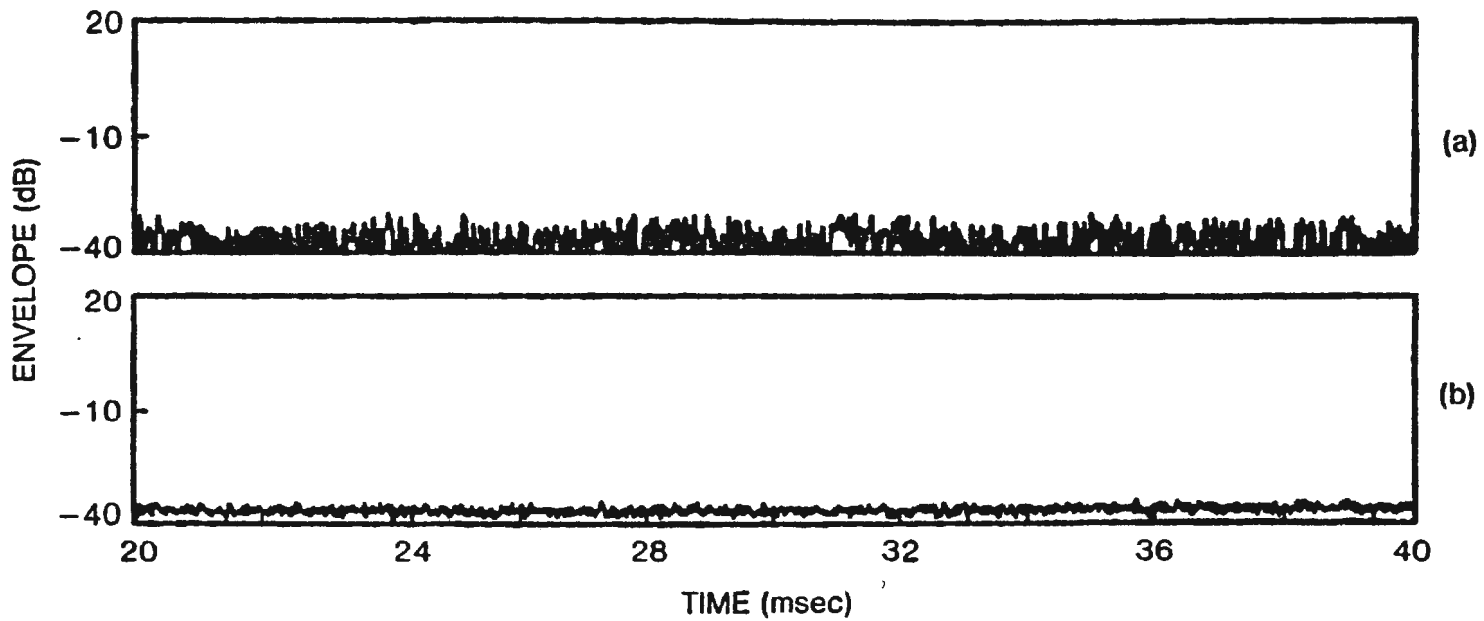

Figure A7. Noise due to computer A/D which is shorted at A/D input for  
(a) one data set and (b) an ensemble average of 25 data sets.

INTERNAL DISTRIBUTION

Code:

01Y F. DiNapoli, P. Cable  
0211 R. Bernier (2)  
021311 Library (3)  
021312 Library (3)  
03  
0302  
039 D. Viccione  
I0 W. VonWinkle, W. Roderick  
20 W. Clearwaters  
32 J. Kingsbury  
3202 C. Walker, T. Fries  
3211 J. Fay, N. Owsley, J. Law, J. Wolcin  
3212 J. Ianniello, R. Kneipfer, R. Hayford  
3213 L. Ng  
3292 A. Ellinthorpe  
33 L. Freeman  
33A B. Cole, P. Herstein, S. Santaniello, D. Kennedy, G. Mayer  
33C J. Hanrahan  
3311 P. King  
3314 C. Carter, A. Quazi, R. Dwyer, A. Nuttall, K. Scarbrough  
333 W. R. Schumacher  
3331 M. Fecher, J. Gorman, D. Browning, J. Chester, R. Dullea, W. Hauck, P. Koenigs, J. Monti (10), R. Nielsen, J. Tattersall  
3332 D. Thomson, E. Jensen  
3333  
35 C. Gardner  
352 J. Hassab  
60 J. Keil  
601  
61  
6291  
701 R. Streit

INTERNAL COPIES - 71