

IMPRESSED CURRENT PULSES FOR HIGH PRESSURE GASDISCHARGES

Jürgen G.H. Salge, Thomas H.G.G. Weise, Ulrich E. Braunsberger,
Institut für Hochspannungstechnik
Technische Universität Braunschweig
Postfach 3329, D-3300 Braunschweig
Federal Republic of Germany

ABSTRACT

An inductive energy storage system supplying a high pressure gasdischarge device is given. It consists of a 500 kJ storage coil with a scheme of commercially available circuit breakers. Current pulses up to 10 kA of nearly rectangular shape can be formed for times in the range of 1 to 10 ms. In addition the set-up of a high pressure gasdischarge device and results of a characteristic high pressure experiment are described. Finally the results are compared with those of a capacitively supplied discharge.

INTRODUCTION

Gasdischarges embedded in a closed tube can generate high pressure pulses via heating processes by taking energy powerfully from an electric circuit. In some applications, i.e. explosively driven circuit breakers /1/ or mass accelerators a substitution of explosives is possible and desirable by electrically heated gasdischarges /2,3/.

High pressure gasdischarges represent loads with variable impedance. In order to investigate such discharges the power supply circuit usually consists of capacitors with current limiting inductors /3/. Due to the interaction of the discharge with the electric circuit a more or less damped sinusoidal current waveform is obtained /4/. The strong interaction between load and supplying circuit makes the interpretation of the basic processes and the investigation of different parameters affecting the energy absorption and pressure generating processes difficult. This situation can be improved by using impressed current pulses from inductive energy stores.

1. Experimental Setup

Fig. 1 shows the set-up of the inductive energy storage system with the high pressure gasdischarge device. The electric circuit consists of a 500 kJ air core coil L, a solid state rectifier and commercially available circuit breakers S1 to S5. The rectifier is connected via the switches S1 and S2 and the transformer to the mains. The discharge circuit is formed by the rectifier, the coil, the closing switch S4, and the discharge device. The opening switch S3, which is used to charge the inductive energy store, is placed in parallel to the rectifier and the coil. With the switch S5 connected in parallel to the discharge device the experiment can be short-circuited.

The high pressure gasdischarge device consists of an inner concentric pin fixed by insulating material in a containment tube made of steel. The pin, the insulating tube, and the bore hole in the containment tube form a cylindric volume. The ends are closed by two electrodes. The electrodes are bridged by a thin wire which initiates the gasdischarge after explosion. A high pressure sensor is placed in the containment tube. The inner pin and the containment tube are connected to the power supply circuit via a coaxial adapter.

In order to start the charging process the switches S1 and S3 are closed. Characteristic current and voltage signals are shown schematically in Fig 2. After closing switch S1 at $t = t_1$ the coil is charged from the mains. When the current I_{L0} is achieved switch S2 is opened at $t = t_2$ (fig. 2a). The commutation of the current into the load circuit is performed by the switches S3 and S4.

S3 is a three-pole circuit breaker. The poles are connected in series in order to increase the total arc

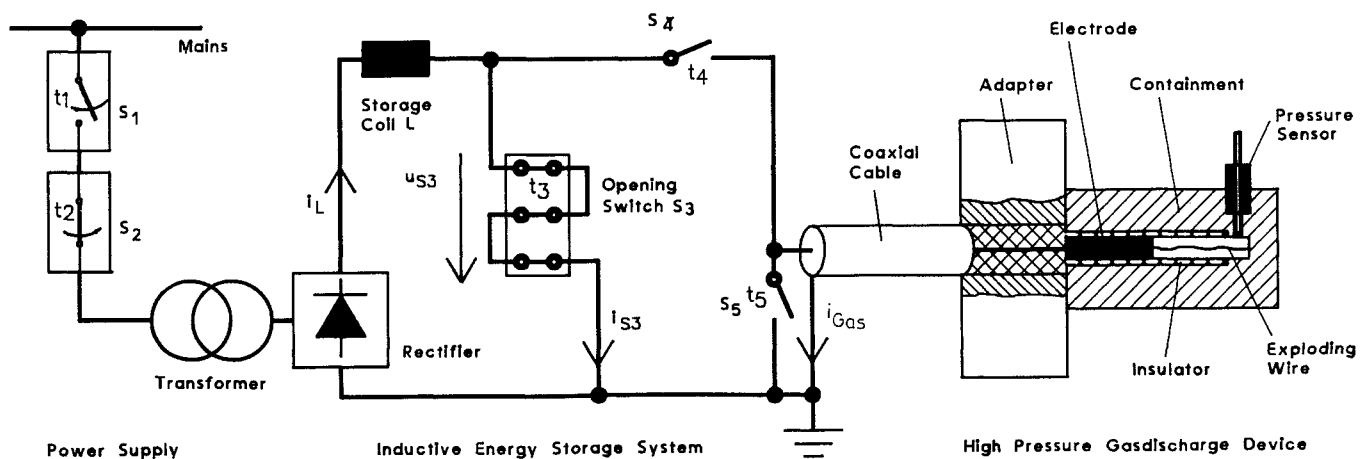

Fig. 1: Set-up of the inductive energy storage system

Report Documentation Page

Form Approved
OMB No. 0704-0188

Public reporting burden for the collection of information is estimated to average 1 hour per response, including the time for reviewing instructions, searching existing data sources, gathering and maintaining the data needed, and completing and reviewing the collection of information. Send comments regarding this burden estimate or any other aspect of this collection of information, including suggestions for reducing this burden, to Washington Headquarters Services, Directorate for Information Operations and Reports, 1215 Jefferson Davis Highway, Suite 1204, Arlington VA 22202-4302. Respondents should be aware that notwithstanding any other provision of law, no person shall be subject to a penalty for failing to comply with a collection of information if it does not display a currently valid OMB control number.

1. REPORT DATE JUN 1989	2. REPORT TYPE N/A	3. DATES COVERED -			
4. TITLE AND SUBTITLE Impressed Current Pulses For High Pressure Gasdischarges		5a. CONTRACT NUMBER			
		5b. GRANT NUMBER			
		5c. PROGRAM ELEMENT NUMBER			
6. AUTHOR(S)		5d. PROJECT NUMBER			
		5e. TASK NUMBER			
		5f. WORK UNIT NUMBER			
7. PERFORMING ORGANIZATION NAME(S) AND ADDRESS(ES) Institut für Hochspannungstechnik Technische Universität Braunschweig Postfach 3329, D-3300 Braunschweig Federal Republic of Germany		8. PERFORMING ORGANIZATION REPORT NUMBER			
9. SPONSORING/MONITORING AGENCY NAME(S) AND ADDRESS(ES)		10. SPONSOR/MONITOR'S ACRONYM(S)			
		11. SPONSOR/MONITOR'S REPORT NUMBER(S)			
12. DISTRIBUTION/AVAILABILITY STATEMENT Approved for public release, distribution unlimited					
13. SUPPLEMENTARY NOTES See also ADM002371. 2013 IEEE Pulsed Power Conference, Digest of Technical Papers 1976-2013, and Abstracts of the 2013 IEEE International Conference on Plasma Science. Held in San Francisco, CA on 16-21 June 2013. U.S. Government or Federal Purpose Rights License.					
14. ABSTRACT An inductive energy storage system supplying a high pressure gasdischarge device is given. It consists of a 500 kJ storage coil with a scheme of commercially available circuit breakers. Current pulses up to 10 kA of nearly rectangular shape can be formed for times in the range of 1 to 10 ms. In addition the set-up of a high pressure gasdischarge device and results of a characteristic high pressure experiment are described. Finally the results are compared with those of a capacitively supplied discharge.					
15. SUBJECT TERMS					
16. SECURITY CLASSIFICATION OF:			17. LIMITATION OF ABSTRACT SAR	18. NUMBER OF PAGES 4	19a. NAME OF RESPONSIBLE PERSON
a. REPORT unclassified	b. ABSTRACT unclassified	c. THIS PAGE unclassified			

voltage generated by the switch. At $t = t_3$ S3 is triggered and starts to separate its contacts igniting an arc in each pole. Increasing arc lengths during the contact removal results in an increase of the voltage U_{S3} as shown in fig. 2c. When this voltage is high enough to commutate the current I_L into the load the high-speed circuit breaker S4 is closed at $t = t_4$. Fig. 2b gives the current decrease in the opening switch during the commutation process. Shortly after the current commutation into the discharge circuit the wire explodes and generates a voltage peak (fig. 2c). The voltage generated by the initiated arc is assumed to be constant. The wire which initially contacts the electrodes in the high pressure gasdischarge device has

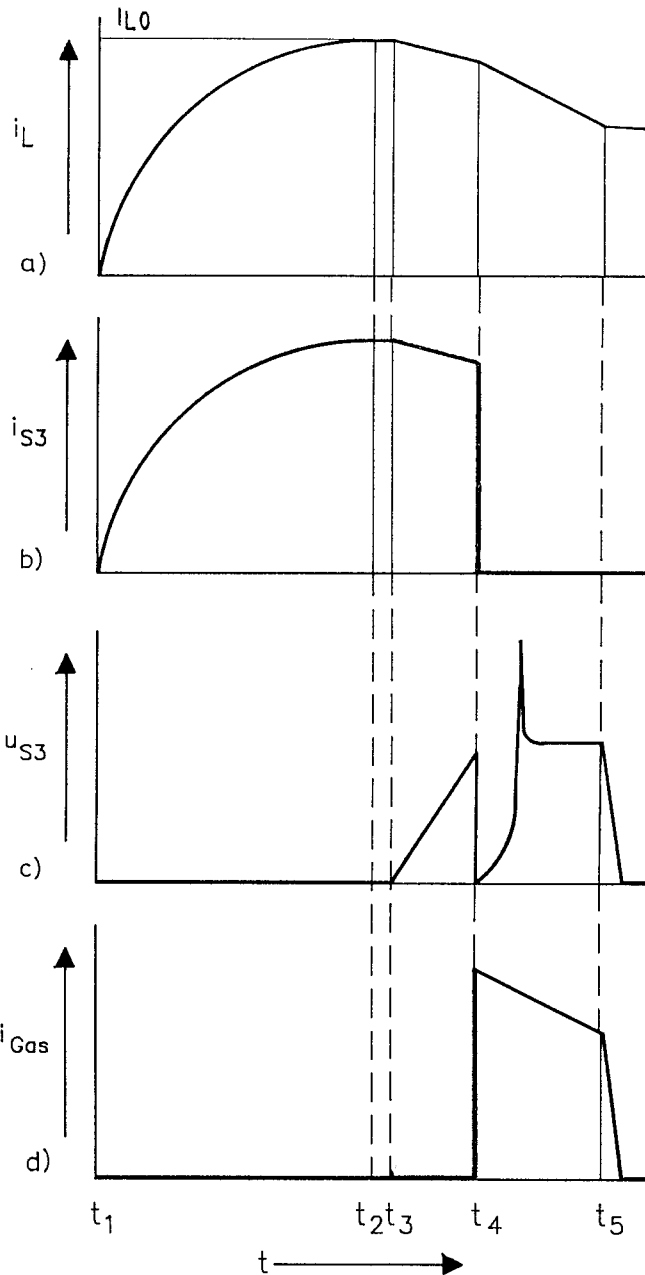

Fig. 2: Current and voltage waveforms in the inductive storage circuit

to carry the current until the opening switch is able to withstand the voltage generated by the wire explosion and by the following arc in order to avoid a reignition of the switch.

Fig. 2d gives the nearly rectangular current waveform in the discharge device branch after a successful commutation. The current rapidly rises to its maximum value and remains nearly constant until the switch S5 is closed at $t = t_5$ to shunt the device.

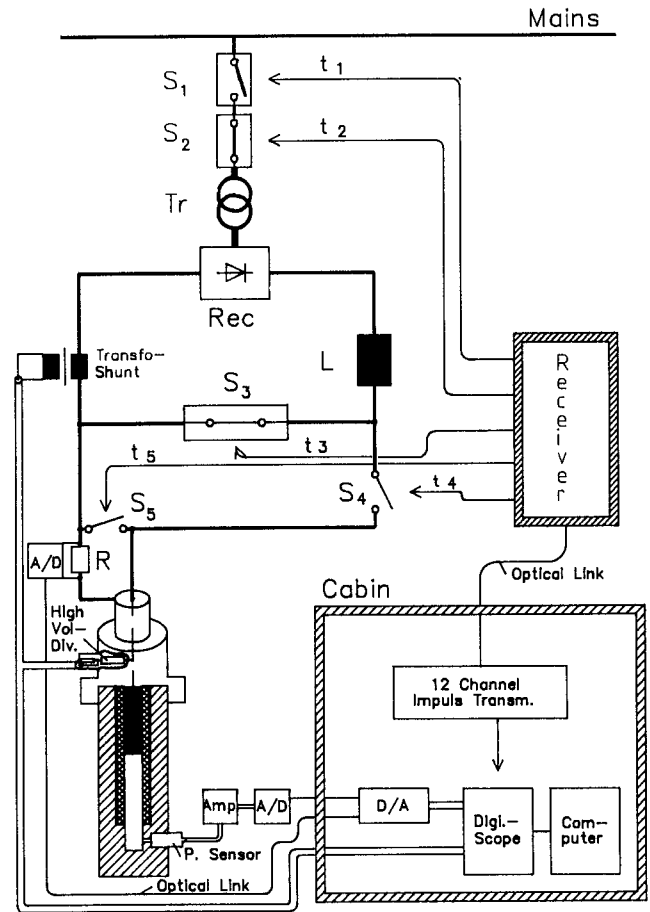

Fig. 3: Setup of the control and measurement system (schematically)

3. Control and measurement system

The setup of the control and measurement system is schematically shown in fig. 3. The chronological sequence of the switching events is controlled by an electronic pulse transmitter. The minimum time delay of its 12 separately adjustable channels is 10 μ s. In order to avoid electromagnetic interference the transmitter is placed in a shielded cabin. The transmitter generates light pulses which are transferred via photoconductors to a receiver. The shielded receiver converts the light pulses into switching pulses for the circuit breakers. The pulse transmitter controls the switching processes.

The arc voltage is measured by a high voltage divider placed in the coaxial adapter of the discharge device. The discharge current is measured by a shunt. Pressure measurement is performed by a high pressure piezoelectric sensor which is connected to a battery

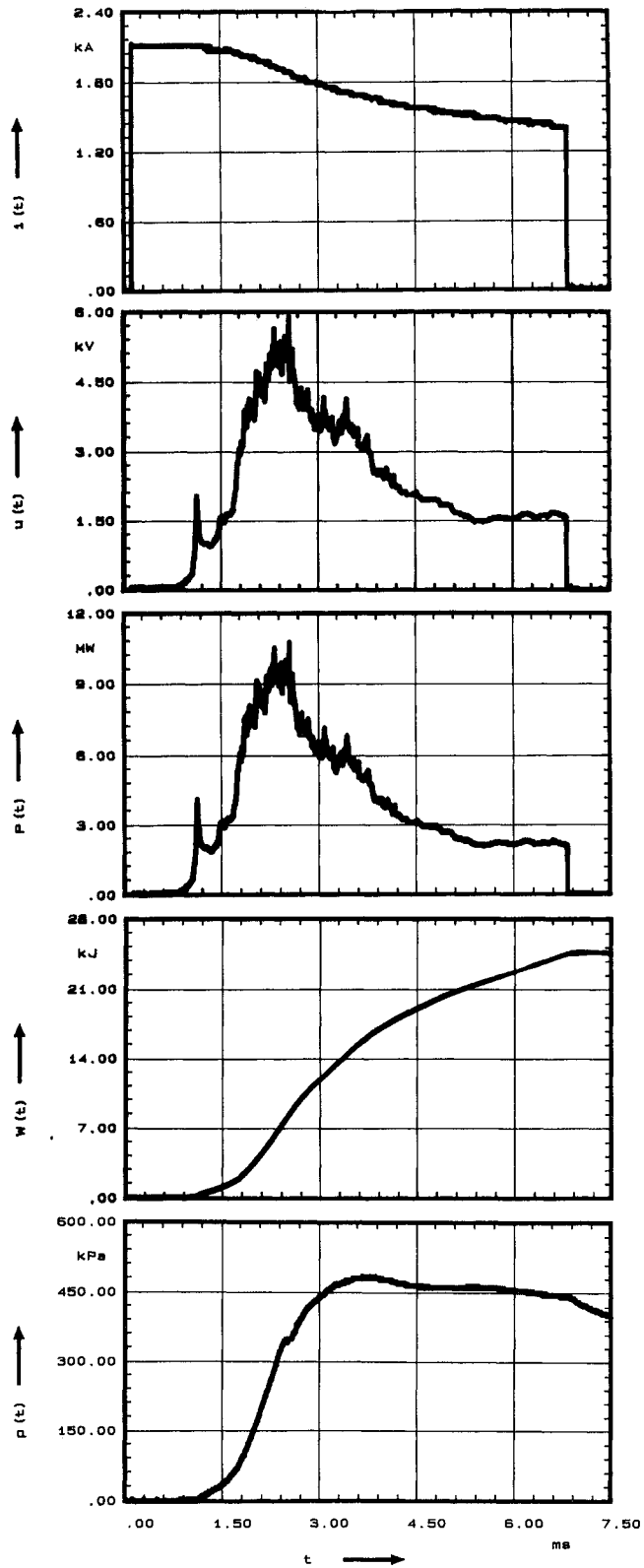

Fig. 4: Current, voltage, power, absorbed energy and pressure waveforms of a characteristic high pressure experiment in an inductive power supply circuit.

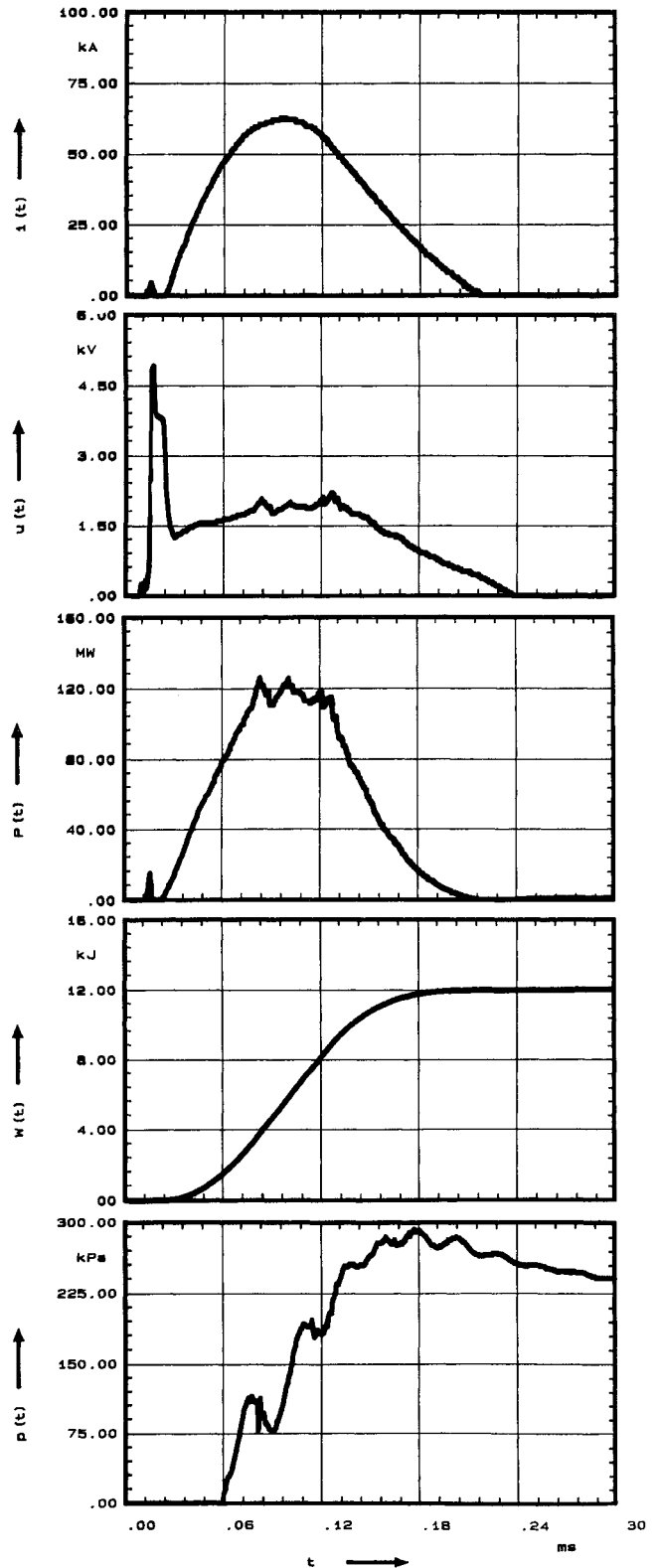

Fig. 5: Current, voltage, power, absorbed energy and pressure waveforms of a characteristic high pressure experiment with capacitive power supply circuit.

supplied charge amplifier. In addition the current through the storage coil is measured by a transformer. In order to avoid ground loops in the measuring system the pressure and the discharge current signals are digitized by 12 bit 1 MHz A/D converters and transferred via optical links to the cabin. A receiver-D/A unit placed in the cabin reconverts the signals. Signal recording and signal processing is performed by a computer controlled digital scope.

4. Experimental Results

Up to now experiments were conducted with the inductive energy supply in order to get information about achievable pressure and voltages the device is able to withstand. Fig. 4 shows the waveforms obtained from a characteristic experiment. Discharge current, arc voltage, power, absorbed energy and the generated pressure are plotted versus time. The coil was charged to $W_0 = 40$ kJ. The discharge volume of 5 cm^3 was partially filled with water. After closing the switch S4 the current $i(t)$ commutates in the discharge device. It rapidly rises to its maximum value of 2 kA and remains nearly constant until the experiment is short-circuited at $t = 7$ ms. In the beginning the voltage signal slowly increases by the increasing resistance of the wire heated by the current. After a short peak of 2 kV generated by the wire explosion the arc voltage increases to a maximum of nearly 6 kV. The interaction of the arc with the evaporated water, the tube walls and the electrode surfaces leads to a fidget voltage waveform.

The arc absorbs energy from the electric circuit with a maximum power of 10 MW. During the current pulse an energy of 24 kJ is conducted into the discharge. When the wire explodes the gas pressure begins to rise. It achieves a maximum of nearly 500 kPa at $t = 3.2$ ms and remains nearly constant until the arc is shunted. Then the pressure decreases exponentially.

In comparison the results of another characteristic experiment performed with a capacitive energy storage system are shown in fig. 5. The supplying circuit consisted of a capacitor and a current limiting inductance /3/. For switching a metal-to-metal switch /5/ was used.

The capacitor charged to $W_0 = 15$ kJ was discharged into the same high pressure device. Shortly after switching the arc is ignited by the explosion of a thin wire. The current is strongly damped. Only one halfwave is obtained with a maximum of 63 kA at $t = 100 \mu\text{s}$. After a peak generated by the wire explosion the arc voltage is nearly proportional to the current and achieves a maximum of 2.4 kV. The discharge absorbs energy with a maximum power of 126 MW. 200 μs after ignition the energy conversion is completed. The absorbed energy of 12.4 kJ leads to a pressure increase of nearly 300 kPa in the discharge volume. After passing its maximum the pressure decreases exponentially.

Conclusion

The comparison of the experiments with inductively and capacitively stored energy of some ten kJ supplying a gas discharge have demonstrated the following:

- with both supplies high pressures can be generated.
- the capacitor delivers the energy into the load at a current of 60 kA and a power of 120 MW in some hundred microseconds.
- the inductive store delivers the energy at a current of 2 kA and a power of 12 MW in some milliseconds.
- due to the large inductance of the inductive store the current remains nearly constant.

Generally can be said that in power supply circuits described in this paper the peak current and its duration can be controlled independently from the behaviour of the load. Thus such a supply circuit is useful to investigate the high pressure generating processes of gas discharges because the current can be kept nearly constant under different test conditions.

References

- /1/ W. Koch, Über die Verwendung von Sprengstoffen in der Schaltertechnik und die dabei erreichbaren Schaltzeiten, Dissertation TU Braunschweig, 1957.
- /2/ S.A. Goldstein e.a., Research and Development of a Plasma Jet Mass Accelerator as a Driver for Impact Fusion, Final Report GTD 84-2, GT-Devices, Alexandria, VA, USA, DOE/ER/10846-T2, June 1984.
- /3/ J.G.H. Salge e.a., Mass Acceleration by Plasma Pulses, IEEE Trans. on Magnetics, Vol. 25, No. 1, January 1989, 495-499.
- /4/ M. Löffler, Über die Einkopplung elektromagnetischer Energie in lineare Hochleistungsimpulsbeschleuniger, Dissertation TU Braunschweig, 1987.
- /5/ P. Dokopoulos, Fast Metal-to-Metal Switch with 0.1 μs Jitter Time, Review of Scientific Instruments, Vol. 39, No. 5, 679-699, May 1968.