

INNOVATIVE INSULATION TECHNIQUES EXAMINED
IN THE SPACE POWER EXPERIMENTS ABOARD ROCKETS PROGRAM

DANIEL B. ALLRED
Defense Nuclear Agency
Electromagnetic Applications Division
6801 Telegraph Road
Alexandria, Virginia 22310

Abstract

Space Power Experiments Aboard Rockets (SPEAR) is an SDIO funded program managed by the Defense Nuclear Agency to produce design guidelines for future space power systems and components. SPEAR I and SPEAR II are rocket borne space experiments designed to measure the ionospheric plasma interactions with exposed highly biased conductors. Data are then examined to determine the feasibility of using the low earth orbit (LEO) environment itself as electrical insulation. Laboratory experiments, theoretical development, large scale space chamber tests, and rocket borne experiments are all integrated into efforts to fully examine numerous issues such as electrical breakdown, current drain, outgassing, voltage conditioning, and charge collection. Results of the SPEAR I project are included as well as the current research on SPEAR II with techniques to use 'space insulation'; vacuum insulation in low density plasma environments.

Introduction

The Strategic Defense Initiative Organization (SDIO) has undertaken the challenge of examining how large scale electrical power systems can be operated in space. A dearth of experimental evidence in both space science and power technology has necessitated that a program be established to determine and understand the germane scientific and engineering issues. First and foremost in this examination is the issue of electrical breakdown and the various insulation methods that might be used to combat it.

Due to weight considerations, large containers of dielectric oil can not be seriously considered to provide the required electrical insulation for high voltage components and systems. This is particularly true considering the large power levels under examination and the corresponding large component and system sizes in such power systems.

Electronegative gases appear more feasible than liquids, however the large containers needed to hold the various components and gas have large surface areas. These are vulnerable to puncture from debris or micrometeoroids. Simple calculations show that small puncture holes on the order of a centimeter or smaller would leak under free molecular flow over a period of days, until the collisional mean free path of the gas remaining in the chamber would be of the order of the hole diameter. Effusive flow is then the predominant mechanism of leakage. The pressure inside the chamber would remain for an extended period at a level very near the optimum for Townsend breakdown. Placing a large meteor shield over the structure to reduce the probability of punctures leads back into mass and volume considerations. Smaller components with smaller surface areas may be candidates for gas insulation. The low probability of survival of components suffering an electrical breakdown in gas insulation must certainly be considered.

The use of vacuum insulation is an even more attractive candidate since the spacecraft is already located in a very low pressure environment. The benefits of vacuum insulation are well characterized.¹

The two most significant issues involved with applying this technique deal with controlling the effects due to the ambient plasma and component outgassing.

SPEAR I

In December of 1987, a space experiment was flown on a suborbital rocket flight from Wallops Island, Virginia to measure the effects of the ionospheric plasma on highly biased conductors. Several papers have been written on SPEAR I^{2,3,4} but a short description should provide enough information to suffice for the purpose of this paper.

Description

SPEAR I biased two 20 cm diameter gold plated aluminum spheres up to 46,000 volts (positively biased) to measure the electron current collectable from the ionosphere at various altitudes up to 370 km. *Figure 1* shows a diagram of the payload and *figure 2* shows the flight trajectory along the experimental time line. The voltages ranged from 5 kV up to 46 kV and were produced by discharging a capacitor through the sphere to a resistive load with a characteristic RC time constant of one second. Current flowing through the resistor was measured by a current monitor. The voltage on the capacitor was also measured and compared to the nominal RC decay curve. Excess current collected from the ionospheric plasma drained the capacitor faster than the circuit load. If an electrical breakdown occurred, voltage collapse would occur producing a large current spike. To protect the circuitry in such events, a series resistor was placed in the circuit to limit the maximum current to 10 Amps.

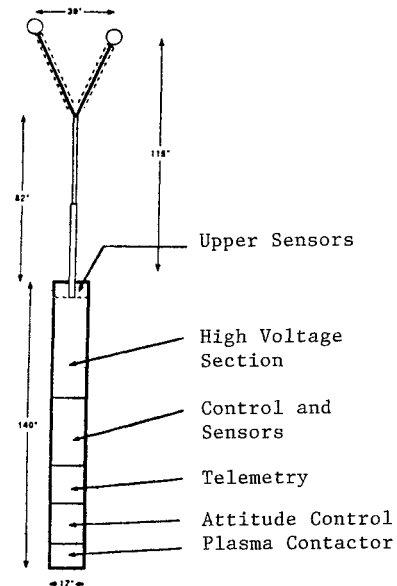

Figure 1 SPEAR I Payload Diagram

Report Documentation Page

Form Approved
OMB No. 0704-0188

Public reporting burden for the collection of information is estimated to average 1 hour per response, including the time for reviewing instructions, searching existing data sources, gathering and maintaining the data needed, and completing and reviewing the collection of information. Send comments regarding this burden estimate or any other aspect of this collection of information, including suggestions for reducing this burden, to Washington Headquarters Services, Directorate for Information Operations and Reports, 1215 Jefferson Davis Highway, Suite 1204, Arlington VA 22202-4302. Respondents should be aware that notwithstanding any other provision of law, no person shall be subject to a penalty for failing to comply with a collection of information if it does not display a currently valid OMB control number.

1. REPORT DATE JUN 1989	2. REPORT TYPE N/A	3. DATES COVERED -	
4. TITLE AND SUBTITLE Innovative Insulation Techniques Examined In The Space Power Experiments Aboard Rockets Program		5a. CONTRACT NUMBER	
		5b. GRANT NUMBER	
		5c. PROGRAM ELEMENT NUMBER	
6. AUTHOR(S)		5d. PROJECT NUMBER	
		5e. TASK NUMBER	
		5f. WORK UNIT NUMBER	
7. PERFORMING ORGANIZATION NAME(S) AND ADDRESS(ES) Defense Nuclear Agency Electromagnetic Applications Division 6801 Telegraph Road Alexandria, Virginia 22310		8. PERFORMING ORGANIZATION REPORT NUMBER	
9. SPONSORING/MONITORING AGENCY NAME(S) AND ADDRESS(ES)		10. SPONSOR/MONITOR'S ACRONYM(S)	
		11. SPONSOR/MONITOR'S REPORT NUMBER(S)	
12. DISTRIBUTION/AVAILABILITY STATEMENT Approved for public release, distribution unlimited			
13. SUPPLEMENTARY NOTES See also ADM002371. 2013 IEEE Pulsed Power Conference, Digest of Technical Papers 1976-2013, and Abstracts of the 2013 IEEE International Conference on Plasma Science. Held in San Francisco, CA on 16-21 June 2013. U.S. Government or Federal Purpose Rights License.			
14. ABSTRACT Space Power Experiments Aboard Rockets (SPEAR) is an SDIO funded program managed by the Defense Nuclear Agency to produce design guidelines for future space power systems and components. SPEAR I and SPEAR II are rocket borne space experiments designed to measure the ionospheric plasma interactions with exposed highly biased conductors. Data are then examined to determine the feasibility of using the low earth orbit (LEO) environment itself as electrical insulation. Laboratory experiments, theoretical development, large scale space chamber tests, and rocket borne experiments are all integrated into efforts to fully examine numerous issues such as electrical breakdown, current drain, outgassing, voltage conditioning, and charge collection. Results of the SPEAR I project are included as well as the current research on SPEAR II with techniques to use 'space insulation'; vacuum insulation in low density plasma environments.			
15. SUBJECT TERMS			
16. SECURITY CLASSIFICATION OF:			17. LIMITATION OF ABSTRACT SAR
a. REPORT unclassified	b. ABSTRACT unclassified	c. THIS PAGE unclassified	
			18. NUMBER OF PAGES 6
			19a. NAME OF RESPONSIBLE PERSON

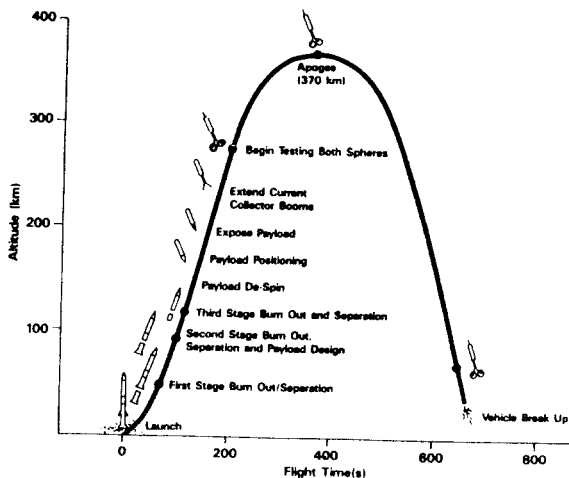

Figure 2 SPEAR I Flight Profile

The power system itself was enclosed in the cylindrical fuselage with SF₆ insulating the power components. Gas insulation was used due to the short duration of the flight. On a suborbital flight, skin punctures due to orbital debris or micrometeoroids and subsequent leakage of the insulating gas did not merit serious consideration.

The spacecraft structure and skin acted as the electrical ground for the power system, the on-board electronics associated with the various plasma instruments, and the telemetry system. Also on-board was a hollow cathode plasma contactor, designed to keep the cylindrical skin of the payload from accumulating a negative electrical charge from the collected plasma electrons. A schematic of the SPEAR I circuit is shown in figure 3.

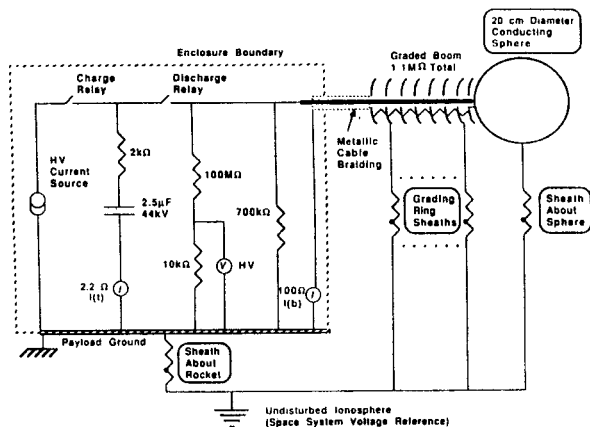

Figure 3 SPEAR I Schematic

Ground Testing

The spacecraft, and functional mock-ups, were tested numerous times on the ground in ambient air and in small and large vacuum chambers, in both vacuum and artificially produced plasmas. Results showed dramatic differences between tests in small versus large vacuum chambers. Smaller chambers, such as at the University of Maryland chamber (2 meter diameter by 5 meter length), showed that electrical breakdown was not occurring up to and including the 46 kV potentials. Under identical test conditions at the NASA B-2 chamber at Plum Brook, Ohio (11.5 meter diameter by 17 meter height), breakdown was occurring

at potentials of only several hundred volts in plasma and at about four kilovolts in vacuum. These results were the cause of much debate and lead to an intense laboratory and analytical effort to explain the results.

The predominant influences on the phenomena were found to be voltage, chamber size, magnetic field strength, electron density, neutral pressure, and electrode size. It was determined, by analytical methods⁶, numerical modeling⁶, and experimentation⁷, that the geomagnetic field increased the path length of the electron trajectories significantly. This combined with the reflexing of electrons trapped in the electrical potential well of the positively biased electrode produced numerous secondary electrons able to initiate a charge avalanche. The role of the chamber wall was to provide initial electron sources as well as secondaries liberated from ion and electron impacts. When the chamber was small compared to the gyroradius and the electrostatic potential well, the electrons were collected by the metallic material comprising the chamber wall. When the chamber was large compared to the same factors, breakdown could occur. This is due to the longer effective path length of the trapped electrons allowing eventual ionization of the neutral gas in the chamber environment. The influence of the voltage was to determine the potential well size and influences the plasma electrodynamics. The size of the electrode determines the charge collection capability as well as to determine the electric field strength. Neutral pressure determines the probability of collisions resulting in ionization and secondary electron production. The magnetic field determines the effective gyroradius.

Results

No electrical breakdowns occurred in space until low altitudes were again reached after apogee. This type of breakdown corresponded to that associated with the relatively well understood low density gas breakdowns. The majority of data without breakdown showed a true exponential decay (following the characteristic circuit RC time constant) with a slight increase in the discharge rate due to ionospheric electron current collection on the sphere and boom. The current collected from the ionosphere was linear with the applied voltage on the sphere. A typical I-V curve for the collected ionospheric electron current appears in figure 4.

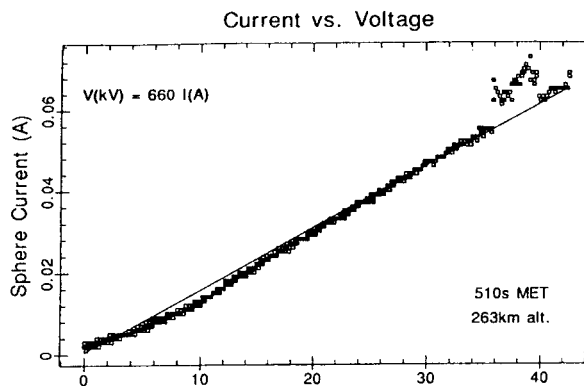

Figure 4 SPEAR I Typical I-V Curve

Outgassing of the payload was substantial. There was no attempt on SPEAR I to facilitate outgassing prior to the flight by conditioning materials such as by pre-outgassing in vacuum chambers or by baking. A neutral pressure gauge on the vehicle measured a much higher pressure in the vicinity of the payload over

that of the ambient environment. At apogee, the difference between the pressure near the vehicle versus the ambient environment was three orders of magnitude. This can be seen in the graph in figure 5.

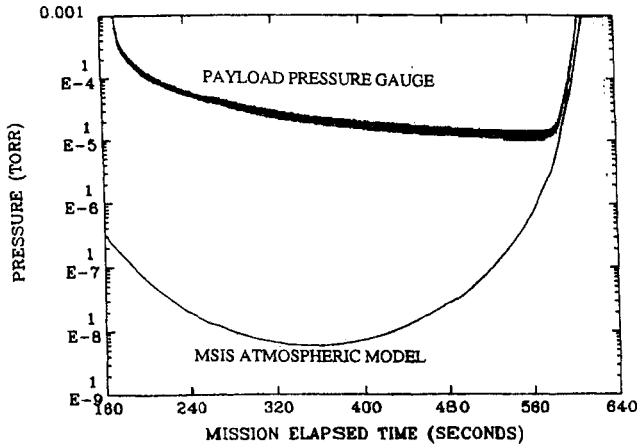

Figure 5 SPEAR I Neutral Pressure Data

During third stage separation from the payload, a lanyard failed to pull the cap off the plasma contactor. With the cap on, the contactor could not function as designed, so the payload floated electrically to relatively high negative potentials (up to 12 kV). Two plasma sheaths were then created around the spacecraft; the ion collecting sheath surrounding the cylindrical body of the payload and the electron collecting sheath surrounding the sphere. This modification to the experiment was most probably responsible for the linear I-V curve. The two main theories involved with positive monopolar spherical electrode current collection predict nonlinear results.^{2,3} The complicated sheath interactions existing on SPEAR I were handled with little difficulty by the NASCAP-LEO and POLAR codes.⁴ Experimental determination of the floating potential was provided by differential electrostatic analyzers, acting as charged particle detectors on the payload.

SPEAR I Conclusions

The difference between the chamber tests and the flight results demonstrated that the influence of the chamber walls were the predominant factor in electrical breakdown in the chamber tests by providing the necessary feedback mechanism.

The results from SPEAR I gave positive indications for the use of space insulation for high voltage electrical power systems. Electrical breakdown was much reduced from ground based testing and current drain was linear and at a level consistent with the monopolar predictions. Nothing debilitating occurred which would have been cause for pessimism in the use of space insulation.

SPEAR I was a scientific experiment using spheres and cylinders, mechanical controls, and was not recovered. The use of space insulation on a much more realistic power system must still be addressed.

SPEAR II

Purpose

SPEAR II looks specifically at power system interactions with the ionosphere. This project again has been broadly based with theory, modeling, laboratory experiments, large space chamber tests, and the space experiment itself. SPEAR II has also had a major

component and development effort instituted. To effectively perform an experiment such as SPEAR II, the power systems had to be developed incorporating completely new technology to use the ionosphere as electrical insulation.

Possible future directed energy loads being considered for the Strategic Defense Initiative depend greatly upon high power in space. These loads will either be high voltage dependent, high current dependent, or some combination of both. To address both regimes, a high voltage experiment, and a high current experiment are being carried aboard the payload. A diagram of the SPEAR II payload appears in figure 6. Most all pertinent issues in space insulation depend on environmental parameters and the large electric and magnetic fields associated with high voltages and high currents respectively. These large time dependent fields, coupled with a conductive plasma environment, under the influence of the earth's geomagnetic field, and in a very complex geometry, have made SPEAR II extremely difficult to handle analytically and numerically. However these are the exact problems intentionally created on SPEAR II in order to force solutions. Providing the answers in a research oriented program could possibly translate to enormous savings in the future in the design of permanent space platforms. A flight profile appears in figure 7.

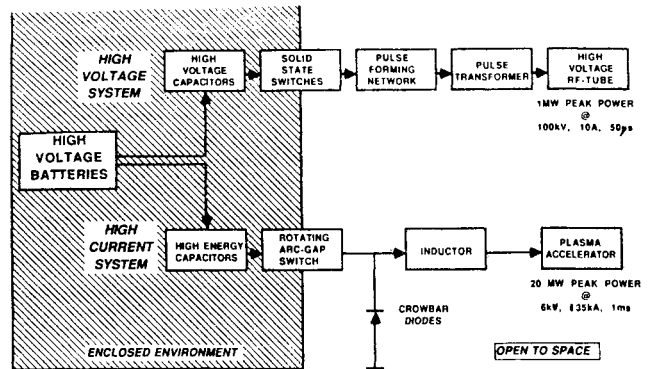

Figure 6 SPEAR II Circuit Block Diagram

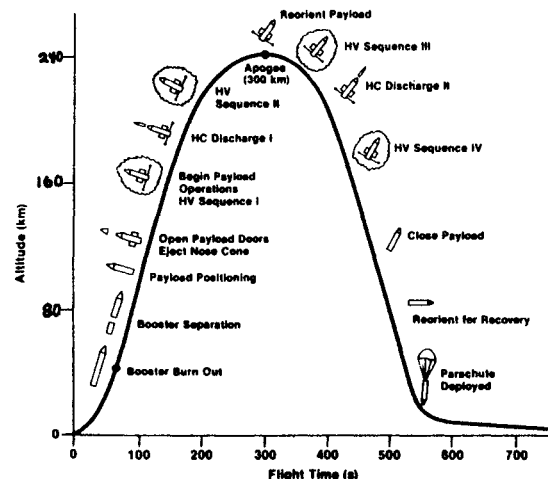

Figure 7 SPEAR II Flight Profile

The components on SPEAR II were designed using a collaborative effort involving industry, universities, and government with the four prime contractors using these inputs into their designs. This fruitful relationship combined talents in a wide range of disciplines. Design engineers have tailored their component designs upon results of laboratory testing with

suggestions provided by experimental and theoretical physicists, research engineers, and engineering physicists. These designs directly incorporate the knowledge of the physical processes taking place with information gained from analytical and computer modeling in conjunction with laboratory tests.

The High Voltage Experiment

The SPEAR II high voltage experiment examines the use of space to provide the required insulation for voltages to over 100 kilovolts. This will be done over a variety of pulse durations from three microseconds to 50 microseconds, in repeated pulses of 50 pulses per second in bursts of one second duration. Table 1 shows the order of the pulse bursts as they will occur. This defines, what is commonly termed, the high voltage matrix. A simplified schematic of the high voltage system appears in figure 8.

Table 1. SPEAR II High Voltage Matrix
 Depicting the Order of the High Voltage Bursts

Pulse Duration microseconds	Voltage kV		
	50	80	100
3	1	4	7
10	2	5	8
50	3	6	9

Each pulse burst consists of 50 pulses fired in one second

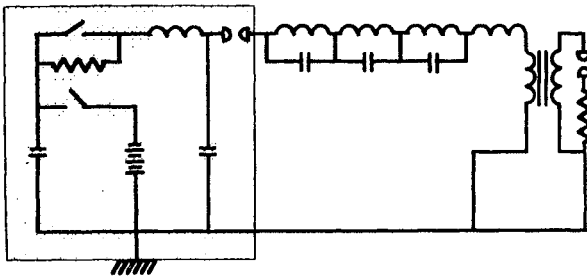

Figure 8 SPEAR II High Voltage System

A six kilovolt NiCd battery stack provides the energy used for the SPEAR II power system. The high voltage system uses gas relays to switch the battery energy into the appropriate type A Pulse Forming Network (PFN) with a separate PFN required for each of the 3, 10, and 50 microsecond pulses. In order to allow three different voltages, relays switch the current through two different resistors to achieve the 50kV and 80kV end voltages, and without resistors to achieve the 100 kV end voltage.

The PFN output goes directly to the primary of a 1:16 pulse transformer. The secondary voltage of the transformer, now at either 50, 80, or 100 kV, inputs the energy into a Klystrode cathode-anode section, which acts as the high voltage load. At 100kV, the nominal secondary current is 10 Amps for a peak power at the load of one megawatt.

The High Current Experiment

The high current experiment is designed to examine the effects of large magnetic fields associated with space power systems. Figure 9 shows a schematic of the SPEAR II high current system. The same six kilovolt NiCd battery stack, used for the high voltage experiment, is also used for the high current experiment. The energy is switched through a relay to charge a 15 kilojoule capacitor. The capacitor then discharges

through a rotating arc gap (RAG) switch into coaxial bus work, through an inductor for pulse conditioning, back into the coaxial bus, and then into the breach of a one meter long plasma accelerator acting as the electrical load.

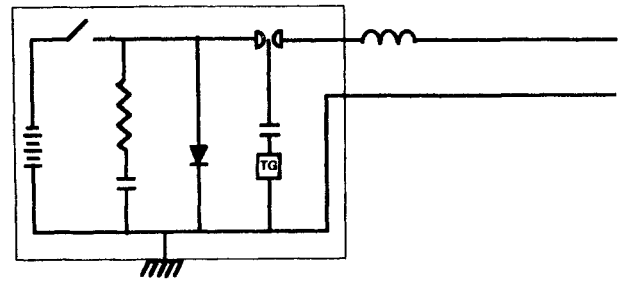

Figure 9 SPEAR II High Current Schematic

The peak current is around 140 kiloamps over a one millisecond pulse duration for a peak power of about 30 megawatts. The peak magnetic flux density occurs in the inductor with a magnitude of about three Tesla.

High Power System Diagnostics

All the diagnostics in the high voltage and high current systems described above are passive in nature. The current and voltage monitors are located in the space environment along with the power system components. Monitor output is via fiber optics to the control and telemetry section. Great care has been taken to assure the various monitors will not be damaged by a catastrophic arc or other type of electrical breakdown.

External Environmental Diagnostics

A separate payload section is devoted to determine the ionospheric conditions throughout the experiment. The localized environment should be greatly affected under the influence of the large electric and magnetic fields produced by the pulse power system. Measuring these time dependent effects is very important to properly evaluate the technique of space insulation.

The external diagnostics included on the payload are summarized in table 2. The most critical of these systems is the on-board video system consisting of eight lenses providing simultaneous views of critical areas of the pulse power system. These images will be telemetered to earth during the flight for real time observation of the experiment.

Table 2. SPEAR II External Diagnostics

Instrument	Purpose
Low light Video system	Examine Breakdowns
35mm Film System	Examine Breakdowns
Photometer	O ⁺ Spectrum
Charge Probe	Spacecraft Polarity
Particle Detectors	Spacecraft Potential
Langmuir Probe	Plasma Characteristics
B-dot Detectors	Local EMI
D-Dot Detectors	Local EMI
Neutral Pressure Gauge	Local Pressure
Magnetometer	B-field Orientation

Charged particle detectors are on-board to provide data needed to determine the magnitude of the spacecraft floating potential. A charge probe will also be used to determine the polarity of the vehicle charge and the

direction of the swinging potential. Difficulties arise with these devices due to the required sampling times being much longer than the pulse durations of the high voltage system. The vehicle floating potential induced by the high voltage pulses will therefore be difficult to determine. Since no single instrument can provide a direct measurement of the vehicle potential, determining this value will depend on postflight computer simulation matching flight data of current and voltage relationships, the external diagnostics data, and comparison of previously measured floating potentials measured under similar conditions in the laboratory.

Additionally, the current state of the art in computer models is limited to applied voltages under dc conditions, where a dc condition is considered to exist when a steady state plasma condition has been established. A new model is therefore being developed to handle the extremely complicated cases involved with SPEAR II: time dependent, nonuniform electromagnetic fields, in partially enclosed outgassing environments, in low density plasmas, with a constant background geomagnetic field, which includes the physics of both current drain and electrical breakdown, with material dependencies also taken into account.

Insulation Techniques Applied to SPEAR II

Mitigation of Volume Breakdown

Many of the typical techniques used to mitigate against volume breakdown on terrestrial pulse power systems were included in the original SPEAR II designs but have been iterated upon repeatedly. The most significant difference in designing for high voltage systems in a low density plasma versus a vacuum is the need to accurately take charged particle trajectories into account. A difficult question resolved under this program was whether to treat the plasma as an increase in conductivity as an initial condition or to treat it as being inherently involved in a very dynamic process evolving in time under the influence of the applied voltage pulses. The answer is definitely the latter. Understanding how and where the plasma particles are moving allows the determination of spatial orientations of components to facilitate proper engineering of the design layout. It also is useful in determining the need for applying modifications to existing components to search for evidence that trajectories should be intercepted or redirected to mitigate against breakdown.

Materials should be carefully selected for their outgassing characteristics if they are to be located in high voltage areas. The influence of neutral particles can not be overemphasized in the breakdown process and engineering should occur with a maximum neutral pressure in mind. SPEAR II is designed with a criterion of 10^{-4} torr as a maximum pressure for proper operation of the high voltage system. To maintain a pressure below this level, the most complex components have been designed to facilitate the outgassing process as fast as possible in the earliest stages when under vacuum. Since outgassing decreases over time the arena chosen for component operations occurs after the large majority of outgassing has already taken place. This has required that the SPEAR II high voltage components be constructed of low outgassing materials and allowed to remain in a vacuum for an extended period of time prior to operation. The payload structure is therefore a vacuum chamber and will be pumped down to a vacuum of below 10^{-4} torr prior to operating the high voltage system.

Models of the payload components have been developed^{10,11} which have been used to determine the required time to allow the components to outgas. Testing has also been used to acquire data for this determination. The idea of purging the payload, backfilling with an inert gas prior to launch, and then venting the trapped gas during ascent was examined extensively and found to be unsuitable for a suborbital flight with components with any degree of geometrical complexity under the influence of even moderate ranges of voltages. This technique may be useful for longer duration orbital missions if the system will not be operated for as long as needed to allow the greater extent of outgassing to have occurred.

The selection of materials is also crucial to reduce the secondary yields of conductors. The SPEAR II high voltage conductor materials are electroless nickel and the skin interiors and structure are made of alodined aluminum. With the need for spacecraft to remain as light as possible, the use of alodined surfaces allows the incorporation of aluminum into the structure without the fear of large secondary yields associated with aluminum oxide. Care was taken to accurately determine the secondary electron yield of materials in high voltage areas in relevant particle energy ranges. Having the structure and skin of the payload conductive also allows free charge migration to occur thus reducing electric field stresses in critical areas.

Mitigation of Surface Flashover

Mapping trajectories for surfaces is as important as for volumes. The worst case occurs when electromagnetic fields direct charged particles toward a triple point. Trajectory mapping can determine what design changes must take place to alleviate this problem. Hiding triple points in low field regions is certainly important in this regard. However, placing triple points in low field regions is no guarantee that the triple point itself is not subjected to charged particle bombardment and thus increasing the localized fields sufficiently for flashover to occur. Intercepting trajectories by conductors to protect triple points and insulator surfaces has been used extensively on both SPEAR I and SPEAR II. Draining this accumulated charge gracefully keeps the localized fields in check by reducing surface insulator charge buildup as well as mitigating against particle bombardment enhanced outgassing.

Minimizing insulator surfaces as much as possible has also been found to be effective. Insulators, due to their inherent characteristic of impeding charge flow, accumulate charge during high voltage operations until either the voltage pulse is stopped or surface flashover occurs across the insulator surface. If no flashover has occurred prior to reduction of the applied voltage the residual charge will most likely be reduced by electrostatic attraction of charges of opposite polarity. Sufficient charge density existed in the LEO environment of SPEAR I to have effectively reduced the spacecraft charge existing on the payload at nearly the same rate as the reduction of the applied voltage. At higher altitudes, with much lower electron densities than in LEO, spacecraft may remain charged for extended periods, especially at geosynchronous altitudes. Artificial means of reducing the charge may be needed at any altitude if accumulated charge is a serious problem. This could be done, for example, with the use of a plasma contactor.

Conductive surfaces will allow the charge to migrate where desired, while insulator surfaces may act as localized sites of accumulated charge. These sites should, in the most general case, be reduced in magnitude, by reduction in size so there is less surface to intercept charged particles (though in some cases this may have the opposite effect by increasing charge density). In any case, insulator surfaces should be shielded by conductors. Replacing insulators with resistive materials has not been implemented in the SPEAR program. Laboratory testing of this method did not prove very successful after a cursory examination due to what was believed to be lower impedance paths forming just off the surface of the resistive material.

Grading the potential in discrete steps is an effective method of reducing the probability of flashover. Bushings have been designed to hold off high voltages using grading rings as in the SPEAR I graded boom and the SPEAR II bushings. The desired function of the insulator material must obviously determine which techniques should be applied.

The Influence of Polarity

Chamber testing of the SPEAR I mock-up, the SPEAR I payload, and the SPEAR II mock-up all demonstrated that up to ten times the voltage standoff could be achieved when the applied voltages were negative rather than positive. The reason appears simply to be due to the differences between the electron and ion charge to mass ratios and the resulting ionization effectiveness.

Acknowledgments

The SPEAR program is made up of enormously talented people performing extremely important work. There is insufficient space to name all who are so vitally contributing to this effort. This collaboration consists of individuals in government agencies and laboratories, in the Department of Defense, the Department of Energy, NASA, as well as those in many organizations in education and industry. This effort is sponsored by the Innovative Science and Technology Office of the Strategic Defense Initiative Organization with some support also coming for the Key Technologies Office. The SPEAR program is managed by the Electromagnetic Applications Division of the Defense Nuclear Agency.

References

- 1 R.V. Latham, High Voltage Vacuum Insulation: the Physical Basis, Academic Press, London, 1981.
- 2 D.B. Allred, J.D. Benson, and H.A. Cohen, "SPEAR: Rocket Flights to Investigate the Innovative Design of High Power Space Systems," in Proceedings of SPIE, Space Structures, Power and Power Conditioning, vol. 871, 1988, pp 317-325.
- 3 D.B. Allred, J.D. Benson, H.A. Cohen, W.J. Raitt, D.A. Burt, I. Katz, G.A. Jongeward, J. Antoniadis, M. Alport, D. Boyd, W.C. Nunnally, W. Dillon, J. Pickett, and R.B. Torbert, "The SPEAR-I Experiment: High Voltage Effects on Space Charging in the Ionosphere," IEEE Transactions on Nuclear Science, vol. 35, no. 6, pp 1386-1393, 1988.
- 4 J.D. Benson, D.B. Allred, and H.A. Cohen, "SPEAR-Space Power Experiments Aboard Rockets," Nuclear Instruments and Methods in Physics Research B40/41, pp 1071-1075, 1989.
- 5 E. Kunhardt, S. Lederman, E. Levi, G. Schaefer, and W.C. Nunnally, "Electrical Breakdown of the Insulating Properties of the Space Environment," in Proceedings of the 13th International Symposium on Discharges and Electrical Insulation, Paris, France, June 1988.
- 6 I. Katz, G.A. Jongeward, V.A. Davis, M.J. Mandell, R.A. Kuharski, J.R. Lilley, Jr., W.J. Raitt, D.L. Cooke, R.B. Torbert, G. Larson, and D. Rau, "Structure of the Bipolar Sheath Generated by SPEAR-I," Journal of Geophysical Research, vol. 94, no. A2, pp 1450-1458, February 1, 1989.
- 7 J. Antoniadis, M. Alport, D. Boyd, and R. Ellis, "Ground Testing of the SPEAR-I High Voltage Booms," in Proceedings of the 13th International Symposium on discharges and Electrical Insulation in Vacuum, Paris, France, 1988.
- 8 I. Langmuir and K.B. Blodgett, "Currents Limited by Space Charge Between two Concentric Spheres," Physical Review, vol. 24, pp. 49, 1924.
- 9 L.W. Parker and B.L. Murphy, "Potential Buildup on Electron Emitting Ionospheric Satellites," Journal of Geophysical Research, vol. 72, pp.1631, 1967.
- 10 L. Gordon, "Outgassing of the SPEAR II Transformer," presented at the SPEAR II Technical Interchange Meeting, Beaverton, Oregon, July, 1988.
- 11 V. Davis and I. Katz, Outgassing rates versus time of the SPEAR II payload, private communications, January-June 1989.