

Final

SHAW AFB CHAFF AND FLARE ENVIRONMENTAL ASSESSMENT

**United States Air Force
Air Combat Command
Shaw Air Force Base**



December 2003

Report Documentation Page

Form Approved
OMB No. 0704-0188

Public reporting burden for the collection of information is estimated to average 1 hour per response, including the time for reviewing instructions, searching existing data sources, gathering and maintaining the data needed, and completing and reviewing the collection of information. Send comments regarding this burden estimate or any other aspect of this collection of information, including suggestions for reducing this burden, to Washington Headquarters Services, Directorate for Information Operations and Reports, 1215 Jefferson Davis Highway, Suite 1204, Arlington VA 22202-4302. Respondents should be aware that notwithstanding any other provision of law, no person shall be subject to a penalty for failing to comply with a collection of information if it does not display a currently valid OMB control number.

1. REPORT DATE DEC 2003		2. REPORT TYPE		3. DATES COVERED 00-00-2003 to 00-00-2003	
4. TITLE AND SUBTITLE Final Shaw AFB Chaff and Flare Environmental Assessment				5a. CONTRACT NUMBER	
				5b. GRANT NUMBER	
				5c. PROGRAM ELEMENT NUMBER	
6. AUTHOR(S)				5d. PROJECT NUMBER	
				5e. TASK NUMBER	
				5f. WORK UNIT NUMBER	
7. PERFORMING ORGANIZATION NAME(S) AND ADDRESS(ES) Air Combat Command (ACC/CEVP),129 Andrews Street,Langley AFB,VA,23665				8. PERFORMING ORGANIZATION REPORT NUMBER	
9. SPONSORING/MONITORING AGENCY NAME(S) AND ADDRESS(ES)				10. SPONSOR/MONITOR'S ACRONYM(S)	
				11. SPONSOR/MONITOR'S REPORT NUMBER(S)	
12. DISTRIBUTION/AVAILABILITY STATEMENT Approved for public release; distribution unlimited					
13. SUPPLEMENTARY NOTES					
14. ABSTRACT					
15. SUBJECT TERMS					
16. SECURITY CLASSIFICATION OF:			17. LIMITATION OF ABSTRACT	18. NUMBER OF PAGES	19a. NAME OF RESPONSIBLE PERSON
a. REPORT unclassified	b. ABSTRACT unclassified	c. THIS PAGE unclassified			

ACRONYMS AND ABBREVIATIONS

A/B	A and B
ACC	Air Combat Command
ACM	Air Combat Maneuvering
ACT	Air Combat Tactics
AEF	Aerospace Expeditionary Forces
AFB	Air Force Base
AFI	Air Force Instruction
AGL	Above Ground Level
Air Force	United States Air Force
ANGS	Air National Guard Station
ATCAA	Air Traffic Control Assigned Airspace
B/C/D	B, C, and D
BFM	Basic Fighter Maneuvers
BSA	Basic Surface Attack
CAS	Close Air Support
CEQ	Council on Environmental Quality
CFR	Code of Federal Regulations
DNL	Average Day-Night Sound Level
DoD	Department of Defense
EA	Environmental Assessment
ECR	Electronic Combat Range
EIAP	Environmental Impact Analysis Process
EO	Executive Order
FAA	Federal Aviation Administration
FONSI	Finding of No Significant Impact
FW	Fighter Wing
GAO	General Accounting Office
GSP	Georgia State Parks
GWR	Georgia's Water Resources
HAP	High Accident Potential
IICEP	Interagency and Intergovernmental Coordination for Environmental Planning
LES-M	Mobile Laser Evaluation System
MOA	Military Operations Area
MSL	Mean Sea Level
MTR	Military Training Route
NEPA	National Environmental Policy Act
NM	Nautical Miles
NRCS	Natural Resources Conservation Service
NWR	National Wildlife Refuge
SAT	Surface Attack Tactics
SCL	South Carolina Lakes
SEAD	Suppression of Enemy Air Defenses
SULMA	Special Use Land Management Area
TI	Tactical Intercepts
USACE	United States Army Corps of Engineers
USEPA	United States Environmental Protection Agency
USDA	United States Department of Agriculture
USGS	United States Geological Survey

Final

SHAW AFB CHAFF AND FLARE
ENVIRONMENTAL ASSESSMENT

**United States Air Force
Air Combat Command
Shaw Air Force Base**

December 2003

**FINAL
FINDING OF NO SIGNIFICANT IMPACT**

1.0 NAME OF THE PROPOSED ACTION

Shaw Air Force Base (AFB) Proposed Chaff and Flare Use in Bulldog A/B and Gamecock B/C/D military operations areas (MOAs).

2.0 DESCRIPTION OF THE PROPOSED ACTION AND ALTERNATIVES

The United States Air Force proposes to authorize the use of training chaff and self-protection flares (not illumination flares) in the Bulldog A/B and Gamecock B/C/D MOAs and overlying air traffic control assigned airspace (ATCAAs). Implementing this action would provide realistic combat training for Shaw AFB and McEntire Air National Guard Station (ANGS) F-16 pilots. Shaw AFB and McEntire ANGS F-16 pilots would continue to deploy chaff and flares in warning areas W-161 A/B and W-177 A/B.

Alternatives to the Proposed Action: Three alternatives to the proposed action were evaluated for this proposal. Each alternative includes the continued training use of chaff and flares in the warning areas W-161 A/B and W-177 A/B. Alternative A is the no-action alternative. Under this alternative, chaff and flares would not be authorized or deployed in the Bulldog A/B or Gamecock B/C/D MOAs and overlying ATCAAs. Alternative B would only authorize use of training chaff and flares in the Bulldog A/B MOAs and overlying ATCAA. Alternative C would only authorize the use of training chaff and flares in the Gamecock B/C/D MOAs and overlying ATCAA. No mitigation measures were applied nor would any need to be implemented under the proposed action or action alternatives in order to arrive at a finding of no significant impact.

3.0 SUMMARY OF ENVIRONMENTAL CONSEQUENCES

This Environmental Assessment (EA) provides an analysis of the potential environmental consequences resulting from implementation of the proposed action and alternatives. Six resource categories were thoroughly analyzed to identify potential impacts: land management, use, and recreational resources; biological resources; soils and water; safety; materials management; and environmental justice. According to the analysis in this EA, implementation of the proposed action or any of the alternatives would not result in significant impacts in any resource category. Implementing any of these alternatives would not significantly affect existing conditions on lands or resources underlying the Bulldog A/B or Gamecock B/C/D MOAs. The following summarizes and highlights the results of the analysis by resource category.

Land Management, Use, and Recreational Resources. Impacts to the use and management of lands underlying the Bulldog A/B and Gamecock B/C/D MOAs in the affected environment would be insignificant. Chaff and flare residual components are not expected to accumulate on soil or water surfaces or change the chemistry of soil or water properties. Therefore, management and use of the lands underlying these MOAs would not change from existing conditions. Recreational resources may be negligibly affected due to rare sightings of chaff or flare residual components (i.e., end caps). Therefore, implementation of either the proposed action or action alternatives would have negligible effects to land management, use, and recreational resources.

Biological Resources. Based on the non-toxicity of chaff and the remote risk of fire from flares, the effects on vegetation, wildlife, and special-status species would be negligible. Impacts to wildlife from startle effect would not be expected due to the high altitude (over 5,000 feet mean sea level [MSL]) of flare deployment. Wetlands are not expected to be impacted by residual components of chaff and flares or dud flares due to the large size of the MOAs used for deployment and the extremely low potential for accumulation of components in any one area. No impacts to these resources are expected under the proposed action and action alternatives.

Soils and Water. Potential impacts to soils and water resources would be negligible because chaff fibers and flare ash would not accumulate to any extent on the surface of these resources. Any accumulation of materials on soil surfaces would be quickly dissolved due to the humid conditions and acidity of the soils. The probability of dud flares accumulating in water resources or a burning flare reaching the ground to ignite a fire is remote given the reliability of flare burn design, advanced deployment systems, and high altitude of deployment. Therefore, impacts to these resources would be minimal under the proposed action and action alternatives.

Safety. The reliability of chaff and flare deployment systems and flare burn design would result in minimal potential safety impacts to the public. RR-188 training chaff does not interfere with FAA radar control systems and has been approved for use in the airspace by the FAA. Flares have been designed to completely burn out within 325 feet of release and under this proposal flares would be released at approximately 5,000 feet MSL, leaving an extensive safety margin to prevent any burning materials from reaching the ground. Likewise, the probability of dud flares is extremely low and such rare occurrences would be dispersed across a wide region. As such, insignificant impacts would be expected from dud flares coming to rest on the ground. The Air Force would also coordinate with local fire and safety officials to educate the public about avoiding any dud flares. Therefore, no significant impacts are anticipated if the proposed action or action alternatives were implemented.

Materials Management. Minimal impacts to this resource would be expected because storage facilities at Shaw AFB and McEntire ANGS are capable of handling the increased inventories of chaff and flares and procedures exist for processing and handling the materials at both locations. The wide dispersal and low

probability of accumulation of chaff and flare residual components under the MOAs would result in only negligible affects to the environment. Implementation of the proposed action and action alternatives would result in no changes to existing handling procedures of chaff and flare inventories.

Environmental Justice. No impacts to low-income and minority populations are anticipated. No changes to current flight levels or flight activities in the MOAs with the potential to affect noise levels would occur under the proposed action or alternatives. Chaff and flares would be widely dispersed throughout the MOAs resulting in no one community or population being disproportionately affected. Therefore, no significant or disproportionate impacts would be expected through implementation of the proposed action or action alternatives due to chaff and flare deployment.

4.0 CONCLUSION

On the basis of the findings of the Environmental Assessment, no significant impact to human health or the natural environment would be expected from implementation of the proposed action or any of the action alternatives. Therefore, issuance of a Finding of No Significant Impact is warranted, and preparation of an Environmental Impact Statement, pursuant to the National Environmental Policy Act of 1969 (Public Law 91-190) is not required.



ROBERT C. BARRETT
Chief, Environmental Division

16 DEC 2003

Date

EXECUTIVE SUMMARY

PROPOSED ACTION AND ALTERNATIVES

The proposed action would authorize F-16 pilots from Shaw AFB 20 Fighter Wing (FW) and McEntire ANG 169 FW to dispense RR-188 training chaff and self-protection flares in the Bulldog A/B MOAs and overlying ATCAA and in the Gamecock B/C/D MOAs and overlying ATCAA. The airspace is currently managed and used by Shaw AFB. Deployment of chaff and flares in warning areas W-161 A/B and W-177 A/B would continue. Under this proposal, no new aircraft would fly in the airspace nor would changes to aircraft operations occur.

The Air Force has identified two action alternatives along with the no-action alternative. Each alternative includes the continued training use of chaff and flares in the warning areas W-161 A/B and W-177 A/B as well as continued authorization of flare use at Poinsett Electronic Combat Range (ECR). Alternative A is the no-action alternative where training chaff and self-protection flares would not be authorized for deployment in the Bulldog A/B or Gamecock B/C/D MOAs and ATCAAs. Alternative B would only authorize the use of training chaff and self-protection flares in the Bulldog A/B MOAs and overlying ATCAA. Alternative C would only authorize the use of chaff and flares in the Gamecock B/C/D MOAs and overlying ATCAA.

SUMMARY OF ENVIRONMENTAL CONSEQUENCES

This EA provides an analysis of the potential environmental consequences resulting from implementation of the proposed action and alternatives. Six resource categories received a thorough interdisciplinary analysis to identify potential impacts: land management, use, and recreational resources; biological resources; soils and water; safety; materials management; and environmental justice. According to the analysis in this EA, implementation of the proposed action or any of the alternatives would not result in significant impacts in any resource category. Implementing any of these alternatives would not affect existing conditions on lands underlying the Bulldog A/B or Gamecock B/C/D MOAs and associated ATCAAs. The following summarizes and highlights the results of the analysis by resource category.

Land Management, Use, and Recreational Resources. Impacts to the use and management of lands underlying the MOAs in the affected environment would be insignificant. Chaff and flare residual components are not expected to accumulate on soil or water surfaces or change the chemistry of soil or water properties. Therefore, management and use of the lands underlying the MOAs would not change from existing conditions. Recreational resources may be negligibly affected due to rare sightings of chaff or flare residual components (i.e., end caps). Therefore, implementation of either the proposed action or action alternatives would have negligible effects to land management, use, and recreational resources.

Biological Resources. Based on the non-toxicity of chaff and the remote risk of fire from flares, the effects on vegetation, wildlife, and special-status species would be negligible. Impacts to wildlife from

EXECUTIVE SUMMARY

This draft Environmental Assessment (EA) describes the potential environmental consequences resulting from the implementation of the United States Air Force's proposal for Shaw Air Force Base (AFB) and McEntire Air National Guard Station (ANGS) to use training chaff and self-protection flares in the Bulldog A/B military operations areas (MOAs) and associated air traffic control assigned airspace (ATCAA) in Georgia and Gamecock B/C/D MOAs and associated ATCAA in South Carolina. This draft EA was prepared by the Air Force, Headquarters Air Combat Command (HQ ACC), in accordance with the National Environmental Policy Act (NEPA), the Council on Environmental Quality (CEQ) regulations implementing NEPA, and Air Force Instruction (AFI) 32-7061 Environmental Impact Analysis Process (EIAP), as promulgated in Title 32 of the Code of Federal Regulations (CFR) Part 989.

PURPOSE AND NEED FOR THE PROPOSED ACTION

The purpose of the proposed action is to provide F-16 pilots from Shaw AFB and McEntire ANGS with the opportunity to conduct effective, realistic, and enhanced chaff and flare defensive training. Defensive training prepares pilots for combat by forcing them to react quickly to counter enemy radar tracking and guidance or infrared systems used to attack aircraft. Providing pilots with these defensive training skills allows them to train as they would fight.

Currently, the only available airspace authorized for chaff and flare training in the vicinity of Shaw AFB and McEntire ANGS consists of overwater warning areas W-161 A/B and W-177 A/B. These airspace units are incapable of providing training beyond air-to-air combat because they lack terrain and ground-based emitters to simulate combat threats. In addition, due to safety reasons, pilots cannot use the warning areas during inclement weather. Flares are authorized in the restricted airspace over Poinsett Electronic Combat Range located south of Shaw AFB, however, the airspace unit is so small that flare use rarely occurs and the restricted airspace cannot adequately meet the defensive countermeasure training needs of the F-16 pilots.

Shaw AFB currently manages and uses several MOAs that could fulfill all the requirements in terms of availability and size to support chaff and flare training activities. Bulldog A/B MOAs and Gamecock B/C/D MOAs and their overlying ATCAAs are currently used for overland training by F-16 pilots from Shaw AFB and McEntire ANGS. These airspace units are close to the two installations and offer priority in scheduling flight operations to Shaw AFB. Importantly, this airspace is linked with ground assets that simulate enemy threats providing additional realistic combat conditions. The Air Force needs to authorize chaff and flare use in these overland MOAs so that Shaw AFB and McEntire ANGS F-16 pilots meet mission training requirements.

startle effect would not be expected due to the high altitude (over 5,000 feet MSL) of flare deployment. Wetlands are not expected to be impacted by residual components of chaff and flares or dud flares due to the large size of the MOAs used for deployment and the extremely low potential for accumulation of components in any one area. No impacts to these resources are expected under the proposed action and action alternatives.

Soils and Water. Potential impacts to soils and water resources would be negligible because chaff fibers and flare ash would not accumulate to any extent on the surface of these resources. Any accumulation of materials on soil surfaces would be quickly dissolved due to the humid conditions and acidity of the soils. The probability of dud flares accumulating in water resources or a burning flare reaching the ground to ignite a fire is remote given the reliability of flare burn design, advanced deployment systems, and high altitude of deployment. Therefore, impacts to these resources would be minimal under the proposed action and action alternatives.

Safety. The reliability of chaff and flare deployment systems and flare burn design would result in minimal potential safety impacts to the public. RR-188 training chaff does not interfere with FAA radar control systems and has been approved for use in the airspace by the FAA. Flares have been designed to completely burn out within 325 feet of release and under this proposal flares would be released at approximately 5,000 feet MSL, leaving an extensive safety margin to prevent any burning materials from reaching the ground. Likewise, the probability of dud flares is extremely low and such rare occurrences would be dispersed across a wide region. As such, insignificant impacts would be expected from dud flares coming to rest on the ground. The Air Force would also coordinate with local fire and safety officials to educate the public about avoiding any dud flares. Therefore, no significant impacts are anticipated if the proposed action or action alternatives were implemented.

Materials Management. Minimal impacts to this resource would be expected because storage facilities at Shaw AFB and McEntire ANGS are capable of handling the increased inventories of chaff and flares and procedures exist for processing and handling the materials at both locations. The wide dispersal and low probability of accumulation of chaff and flare residual components under the MOAs would result in negligible effects to the environment. Implementation of the proposed action and action alternatives would result in no changes to existing handling procedures of chaff and flare inventories.

Environmental Justice. No impacts to low-income and minority populations are anticipated. No changes to current flight levels or flight activities in the MOAs with the potential to affect noise levels would occur under the proposed action or alternatives. Chaff and flares would be widely dispersed throughout the MOAs resulting in no one community or population being disproportionately affected. Therefore, no significant or disproportionate impacts would be expected through implementation of the proposed action or action alternatives due to chaff and flare deployment.

TABLE OF CONTENTS

TABLE OF CONTENTS

EXECUTIVE SUMMARY	ES-1
1.0 PURPOSE AND NEED FOR THE PROPOSED ACTION.....	1-1
1.1 Introduction	1-1
1.2 Background	1-1
1.3 Purpose and Need for this Environmental Assessment	1-6
1.4 Regulatory Requirements and Other Direction	1-7
1.5 Document Organization.....	1-7
2.0 DESCRIPTION OF THE PROPOSED ACTION AND ALTERNATIVES	2-1
2.1 Description of Training Chaff and Flares	2-1
2.2 Alternative Identification Processes.....	2-5
2.3 Proposed Action and Alternatives.....	2-6
2.3.1 Airspace Structure and Use	2-6
2.3.2 Flare and Chaff Use.....	2-10
2.4 Environmental Impact Analysis Process.....	2-11
2.5 Other Regulatory and Permit Requirements.....	2-12
2.6 Mitigation Measures.....	2-12
2.7 Summary of Environmental Consequences	2-13
3.0 DESCRIPTION OF THE AFFECTED ENVIRONMENT AND ENVIRONMENTAL CONSEQUENCES	3-1
3.1 Analysis Approach.....	3-1
3.2 Land Management, Use, and Recreational Resources.....	3-4
3.3 Biological Resources.....	3-7
3.4 Soils and Water.....	3-10
3.5 Safety.....	3-13
3.6 Materials Management	3-17
3.7 Environmental Justice.....	3-20
4.0 CUMULATIVE EFFECTS AND IRREVERSIBLE AND IRRETRIEVABLE COMMITMENT OF RESOURCES.....	4-1
4.1 Cumulative Effects.....	4-1
4.2 Scope of Cumulative Effects Analysis	4-1
4.3 Irreversible and Irretrievable Commitment of Resources.....	4-2
5.0 REFERENCES CITED	5-1
6.0 PERSONS AND AGENCIES CONTACTED	6-1
7.0 LIST OF PREPARERS AND CONTRIBUTORS.....	7-1

APPENDIX A CHARACTERISTICS OF CHAFFA-1

APPENDIX B CHARACTERISTICS OF FLARES.....B-1

APPENDIX C INTERAGENCY AND INTERGOVERNMENTAL COORDINATION FOR ENVIRONMENTAL PLANNING.....C-1

APPENDIX D AGENCY RESPONSES TO INTERAGENCY AND INTERGOVERNMENTAL COORDINATION FOR ENVIRONMENTAL PLANNING.....D-1

APPENDIX E FEDERAL SPECIAL-STATUS SPECIES POTENTIALLY FOUND IN COUNTIES UNDER THE PROPOSED ACTION AND ALTERNATIVES.....E-1

LIST OF FIGURES

Figure 1-1 Existing and Proposed Airspace for Chaff and Flare Deployment 1-2

Figure 2-1 MOAs Included in Proposed Action..... 2-2

Figure 2-2 Alternative B – Proposed Chaff and Flare Airspace 2-7

Figure 2-3 Alternative C – Proposed Chaff and Flare Airspace 2-8

Figure 3-1 Existing Land Uses Under Bulldog A/B and Gamecock B/C/D MOAs..... 3-5

LIST OF TABLES

Table 2-1 Altitude Structure of MOAs and ATCAAs 2-9

Table 2-2 Proposed Chaff and Flare Use per Year..... 2-10

Table 2-3 Proposed Altitudes for Deploying Chaff and Flares in the MOAs and ATCAAs..... 2-11

Table 3-1 Resources Analyzed in the Environmental Impact Analysis Process..... 3-2

Table 3-2 Proposed Annual Distribution of Chaff and Flares in the MOAs 3-19

CHAPTER 1

PURPOSE AND NEED FOR THE PROPOSED ACTION

CHAPTER 1

PURPOSE AND NEED FOR THE PROPOSED ACTION

1.1 INTRODUCTION

The United States Air Force (Air Force) proposes to authorize use of training chaff and self-protection flares (referred to as chaff and flares) in airspace managed and used by Shaw Air Force Base (AFB), South Carolina (Figure 1-1). Under the proposed action, the Air Force would authorize use of chaff and flares in the Bulldog A and B (A/B) and Gamecock B, C, and D (B/C/D) military operations areas (MOAs) and overlying air traffic control assigned airspace (ATCAA) by F-16 aircraft based at Shaw AFB and McEntire Air National Guard Station (ANGS). The F-16 aircraft stationed at these installations would also continue to conduct defensive chaff and flare training in overwater warning areas W-161 A/B and W-177 A/B as well as continued authorization of flare use at Poinsett Electronic Combat Range (ECR).

As part of the environmental analysis process, the Air Force prepared this Environmental Assessment (EA) to determine the potential environmental impacts of implementing this action. In addition to the proposed action—authorize chaff and flare deployment in Bulldog A/B and Gamecock B/C/D MOAs/ATCAAs, the Air Force identified two action alternatives. Each action alternative represents a subset of the proposed action with use of one set of MOAs/ATCAAs (e.g., Bulldog A/B) or the other (e.g., Gamecock B/C/D). From this point forward, the Bulldog A/B and Gamecock B/C/D MOAs/ATCAAs combined airspace units will be referred to as Bulldog A/B MOAs and Gamecock B/C/D MOAs. The Air Force, in accordance with Council on Environmental Quality Regulations (40 CFR 1502.14(d)) implementing the National Environmental Policy Act (NEPA), also analyzed the no-action alternative. No-action would constitute status quo conditions where chaff and flare training would continue only in the warning areas W-161 A/B and W-177 A/B.

1.2 BACKGROUND

Shaw AFB lies in the east central part of South Carolina, approximately 35 miles east of the capital city, Columbia, and 10 miles west of the city of Sumter. McEntire ANGS is located approximately 15 miles east of Columbia and 20 miles west of Shaw AFB. The 20th Fighter Wing (20 FW) at Shaw AFB and 169 FW at McEntire ANGS operate combat-coded F-16 aircraft that currently train in the Bulldog A/B and Gamecock B/C/D MOAs, as well as in the overwater warning areas. The 20 FW and 169 FW also form integral parts of Aerospace Expeditionary Forces (AEF). The Air Force has divided its forces into ten AEFs and two Aerospace Expeditionary Wings to make worldwide deployments more predictable and manageable. An AEF is a “packaged” group of different types of aircraft (e.g., fighters, bombers, tankers, surveillance) with a mix of capabilities suited to the tasking to overseas locations for 90 days or longer. The AEFs consist of wings or squadrons from multiple United States bases and may operate as a unit or be integrated with other forces overseas. As part of an AEF, the F-16s from Shaw AFB and McEntire ANGS

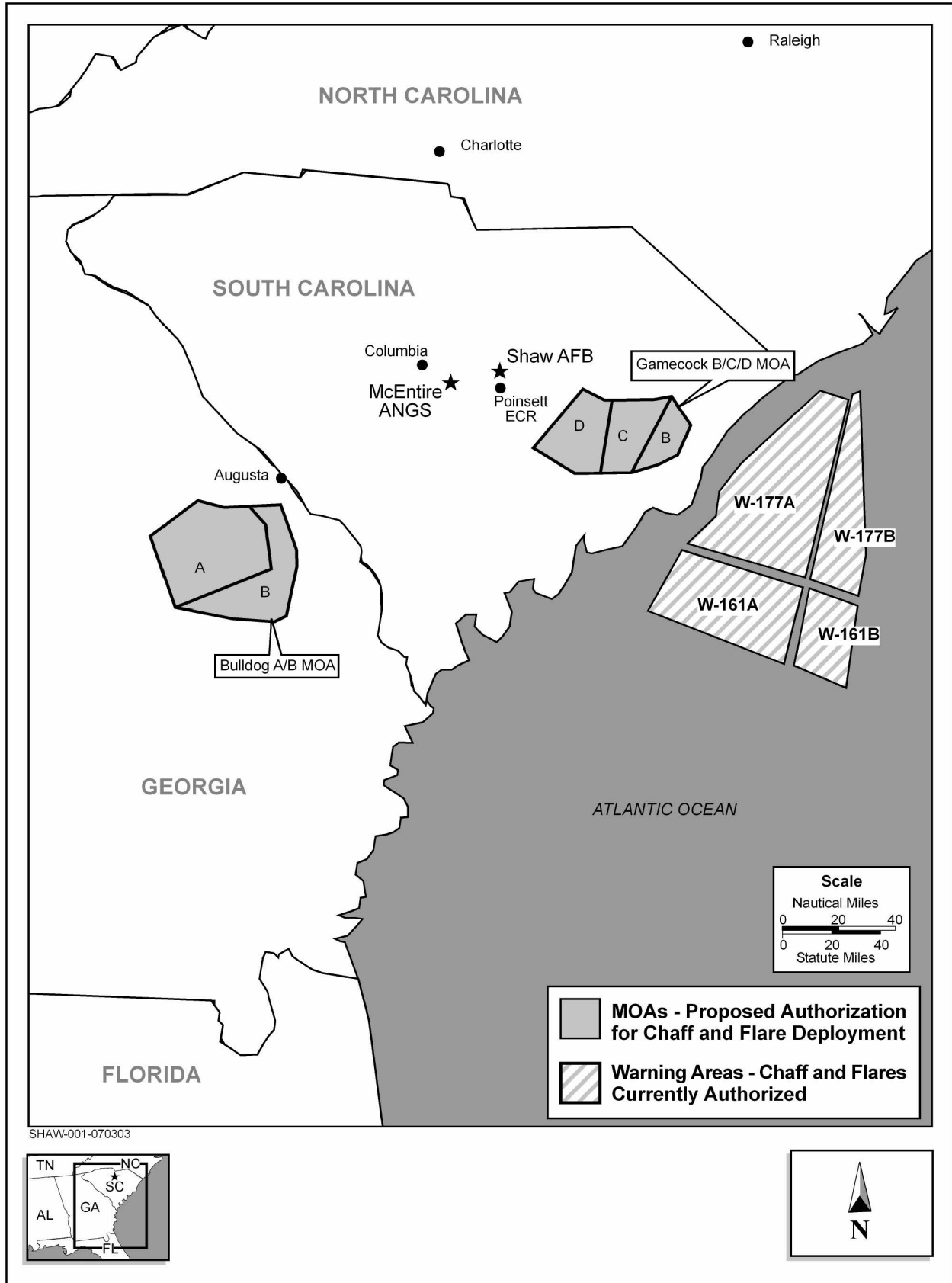

Figure 1-1 Existing and Proposed Airspace for Chaff and Flare Deployment

routinely deploy to the world's "hot spots" and face combat conditions. Both the 20 FW and 169 FW flew hundreds of combat missions during Operation Iraqi Freedom. In these combat situations, pilots faced threats from sophisticated enemy radars, anti-aircraft defenses, surface-to-air missiles, and air-to-air missiles. To ensure their continued survival and ability to complete missions, pilots must be trained to instantly respond to and defend against such threats.

Realistic defensive training provides pilots with the skills to rapidly respond to opposing threats, reflexively maneuver against enemy aircraft, and accurately dispense countermeasures against these combat threats. These countermeasures include chaff that confuses enemy search radars and radar-guided missiles, and flares that decoy heat-seeking missiles and sensors. The 20 FW currently conducts defensive countermeasures (i.e., chaff and flares) training only in overwater warning areas W-161A/B and W-177A/B; the 169 FW uses these airspace units as well for the same type of training.

Current Missions. The current mission of both 20 FW and 169 FW is to develop and maintain Fighter Wings capable of day, night, and all-weather combat operations across the world. F-16 aircraft, as multipurpose fighters, fulfill numerous roles in combat including air-to-ground and air-to-air operations. As part of the Air Force's AEF, Shaw AFB F-16s participated in Operation Iraqi Freedom with more than 800 Air Force personnel and 25 F-16 fighters deployed to forward operating locations in Southwest Asia. Shaw's F-16 pilots flew various combat missions over Iraq including Suppression of Enemy Air Defenses (SEAD) missions; a total of 676 sorties were flown with aircrews totaling 3,803 hours of combat time. During Operation Desert Shield (1990/1991), the 20 FW deployed to airfields in the United Arab Emirates and as part of Operation Desert Storm flew combat sorties over Iraq and Kuwait. Subsequently, 20 FW personnel and aircraft have rotated in and out of Southwest Asia on a routine basis in support of Operations Northern and Southern Watch.

For the 169 FW, all of the F-16s were mobilized and deployed to southwest Asia as part of Operation Iraqi Freedom (February 2003). These aircraft flew more than 400 combat missions, performing the SEAD mission and numerous precision bombing missions over Iraq. In addition, the 169 FW participated routinely in the AEF patrol of Iraqi no-fly zones. Several other deployments in the recent past included Operation Southern Watch (Qatar 1996), Operation Northern Watch (Turkey 2000), and again to Southern Watch in Saudi Arabia (2001).

Training for Missions. In order to meet the challenges of combat, F-16 pilots train in a realistic manner and under conditions mirroring combat as much as possible. They must train for and remain proficient in all aspects of combat, both from the air by opposing enemy aircraft and from the ground by surface-to-air missiles, anti-aircraft artillery, and supporting tracking systems. Pilots under combat conditions need to make split-second decisions, under high G-forces, and at airspeeds that can reach twice the speed of sound for engagements that may last only 2 to 3 minutes. Therefore, training must simulate as close as possible the enemy threats pilots will face in battle. Defensive training forces pilots to react rapidly to counter

enemy radar tracking and guidance or infrared (heat) seekers used to deliver lethal weaponry. To combat these tracking and/or infrared systems, a pilot must employ defensive countermeasures such as chaff and flares as part of mission tactics. Chaff is used to counter radar-controlled systems; flares are used to counter infrared systems.

SEAD constitutes the major mission of the 20 FW and 169 FW; on a SEAD mission, pilots neutralize or destroy ground-based threat and tracking systems. To meet this prime objective and fulfill other combat roles, both air-to-air and air-to-ground combat maneuvers are employed and chaff and flares play a vital role. The following provides a brief description of the types of training undertaken in Shaw AFB airspace in support of SEAD and other missions; chaff and flares could be used in any of these scenarios.

Air-to-Air

- *Basic Fighter Maneuvers (BFM)*. This fundamental training is conducted with two aircraft practicing offensive and defensive maneuvering against each other.
- *Air Combat Maneuvering (ACM)*. This training emphasizes intra-aircraft flight coordination, survival tactics, and two-ship maneuvering against an adversary.
- *Air Combat Tactics (ACT)*. Normally requiring three or four aircraft, this training involves designating friendly and enemy forces to simulate combat air forces.
- *Tactical Intercepts (TI)*. This training involves two or more aircraft—the target and intercept—separated beyond each aircraft's radar detection capability. The target aircraft attempts to penetrate an assigned area protected by the interceptor. The interceptor must detect the target, maneuver to identify the aircraft, and then position itself to successfully intercept the target.

Air-to-Ground

- *Basic Surface Attack (BSA)*. This requires air-to-ground delivery of ordnance, such as training ordnance, on a conventional range like Poinsett Electronic Combat Range.
- *Surface Attack Tactics (SAT)*. SAT is normally practiced in a block of airspace such as a MOA, Restricted Area, or range that provides enough room to maneuver. Under this training, the pilots practice precise timing for approaching (ingress to) the target, acquiring the target, and exiting (or egress from) the target area.
- *Close Air Support (CAS)*. This type of training focuses on providing direct support to ground forces in close proximity to enemy forces.

Training Airspace. The F-16s from the 20 FW and 169 FW use several types of airspace to conduct the training described above: MOAs, ATCAAs, warning areas, restricted areas, and military training routes (MTRs). Although restricted areas and MTRs play important roles in providing an integrated suite of airspace assets used for training, they do not comprise components of the affected environment for the proposed action and alternatives. As such, they warrant no further detailed discussion. In contrast, MOAs,

ATCAAs, and warning areas, as described below, are all components of the proposed action and alternatives.

Military Operations Areas are blocks of special use airspace designated by the Federal Aviation Administration (FAA) with defined vertical and lateral boundaries below 18,000 feet MSL. MOAs separate nonhazardous military operations from nonparticipating air traffic operating under instrument flight rules. When a MOA is active, the FAA generally routes other air traffic around it, but nonparticipating aircraft (civil and military) flying under visual flight rules may transit an active MOA by employing see-and-avoid procedures. Because of the varied types of flight activities conducted in a MOA, altitudes and flight paths are random and may vary considerably. The Bulldog A/B and Gamecock B/C/D MOAs are currently used for training by the 20 FW, and 169 FW, and other units. Under the proposed action, the Air Force would authorize use of defensive countermeasure chaff and flares for the 20 FW and 169 FW in these MOAs.

Air Traffic Control Assigned Airspace is airspace, often overlying a MOA, extending from 18,000 feet MSL to the altitude assigned by the FAA. Assigned on an as-needed basis and established by a letter of agreement between a military unit and the local FAA Air Route Traffic Control Center, each ATCAA provides additional airspace for training, especially air combat activities. ATCAAs are released to military users by the FAA only for the time they are to be used, allowing maximum access to the airspace by civilian aviation. ATCAAs can be activated over Bulldog B and Gamecock D MOAs, and would be used for training with chaff and flares.

Warning Areas provide offshore airspace for military aircraft training and serve to warn nonparticipating aircraft of the potential danger. Warning area altitudes can extend from as low as the surface up to as high as unlimited. These large airspace units may overlie domestic or international waters, or both. Warning areas (W-161 A/B and W-177 A/B) are currently used and will continue to be used, for chaff and flare training.

Other Training Assets. In order to add further realism to training, Shaw AFB has ground-based electronic threat emitters in areas either underlying or adjacent to the military training airspace. The units provide electronic signatures that simulate ground-based “enemy” radar systems, threaten pilots during training, and require pilots to take defensive maneuvers for self-protection. Five emitters support combat training in the Gamecock B/C/D MOAs and are located on underlying land near these MOAs. One existing emitter lies adjacent to Bulldog A/B MOAs and the Air Force plans to place two emitters under the Bulldog A/B MOAs providing a total of three emitters supporting combat training (Connelly 2003).

1.3 PURPOSE AND NEED FOR THIS ENVIRONMENTAL ASSESSMENT

The purpose of the proposed action is to provide F-16 pilots from Shaw AFB and McEntire ANGS with the opportunity to conduct effective, realistic, and enhanced chaff and flare defensive training. These pilots need defensive training to adequately prepare for combat by allowing them to train like they fight. With the growing sophistication of adversarial equipment and tactics, the need for combat-condition training has increased. Survival in combat demands that training assist pilots in developing instantaneous and intuitive responses to various threats. Under combat conditions pilots must accomplish in-flight analysis of weapons; survey the radar scope and defensive sensors for adversaries; detect, sort, identify, and target adversarial weapons; communicate with other aircrews; employ tactics and weapons, using timely defensive countermeasures; assess the success of the measures and respond accordingly—all within minutes. Realistic training requires assets that simulate combat conditions. For the Air Force, this means the majority of combat missions occur over land.

Currently the only available airspace authorized for chaff and flare training in the vicinity of Shaw AFB and McEntire ANGS are warning areas W-161 A/B and W-177 A/B. These units suffer from limitations that constrain their utility and realism:

- no terrain to simulate combat conditions and
- no ground-based emitters to simulate combat threats.

In addition, inclement weather conditions limit use of the overwater airspace due to safety reasons (i.e., winds and wave height would hinder any search and rescue operations in the event of a pilot going down).

Flare use is permitted only in the restricted airspace over Poinsett Electronic Combat Range (located south of Shaw AFB). However, due to this limitation (in restricted airspace only) and the airspace unit's small size, flare use rarely occurs and the restricted airspace cannot adequately meet the training needs of using both chaff and flares for the 20 FW and 169 FW for defensive countermeasures.

In contrast, Bulldog A/B and Gamecock B/C/D MOAs and overlying ATCAAs (Bulldog B ATCAA and Gamecock D ATCAA) fulfill all the requirements in terms of availability and size to support chaff and flare training activities.

- Pilots from three F-16 squadrons at Shaw AFB and the one F-16 squadron at McEntire ANGS already use this overland airspace for training,
- These airspace units are close to Shaw AFB and McEntire ANGS and offer priority in scheduling flight operations (managed by Shaw AFB), and
- The airspace is or will be linked with ground assets simulating enemy threats providing pilots with training that simulates most combat conditions.

By adding the ability to use chaff and flares during training in the airspace units, the mission requirements for the 20 FW and 169 FW would be met. Therefore, the Air Force needs to authorize chaff and flare use in the Bulldog A/B and Gamecock B/C/D MOAs.

1.4 REGULATORY REQUIREMENTS AND OTHER DIRECTION

This EA has been prepared in accordance with the National Environmental Policy Act (NEPA), Council of Environmental Quality (CEQ) regulations, and Air Force Instruction (AFI) 32-7061, as promulgated in Title 32 of the Code of Federal Regulations (CFR) Part 989, and Department of Defense (DoD) Directive 6050.1.

1.5 DOCUMENT ORGANIZATION

This EA has been organized so that the reader can easily understand the proposed action and alternatives and the potential environmental impacts that could occur if any one of them were implemented. This chapter, Purpose and Need, presents the background for both the purpose and need for the proposed action. Chapter 2.0, Description of the Proposed Action and Alternatives, provides a detailed description of the proposed action and alternatives considered for analysis. Chapter 3.0, Affected Environment and Environmental Consequences, addresses the existing environmental conditions for various resources (e.g., biological resources, soils and water, safety) and then presents the environmental consequences (i.e., potential impacts) to these resources should the proposed action and/or alternatives be implemented. Both the existing conditions and environmental consequences are presented in the same section to provide the reader with both what is found now and what might occur if the proposed action or alternatives were implemented. Chapter 4.0, Cumulative Effects and Irreversible and Irrecoverable Commitment of Resources, outlines past, present, and foreseeable local, state, and federal agency actions in the affected environment of the proposed action and analyzes potential cumulative impacts these actions might have, in conjunction with this proposed action or alternatives, on the environment. Chapter 5.0, 6.0, and 7.0 present the References Cited, Persons and Agencies Contacted, and a List of Preparers and Contributors, respectively. Appendices are provided to support analysis in the EA.

CHAPTER 2

DESCRIPTION OF THE PROPOSED ACTION AND ALTERNATIVES

CHAPTER 2

DESCRIPTION OF THE PROPOSED ACTION AND ALTERNATIVES

The Air Force proposes to authorize use of chaff and flares as defensive countermeasures for training in two sets of MOAs and associated ATCAAs (Figure 2-1): Bulldog A/B MOAs and Bulldog B ATCAA; and Gamecock B/C/D MOAs and Gamecock D ATCAA. Three F-16 squadrons from Shaw AFB's 20 FW and one squadron from McEntire ANG's 169 FW would continue to use these airspace units for training and would add the use of chaff and flares. Authorizing chaff and flare use in the MOAs and ATCAAs would enhance the F-16 pilots' ability to train like they fight, improve training realism, and increase survivability in combat.

This chapter describes the proposed action and alternatives. Under the proposed action, chaff and flare use would be authorized in both the Bulldog and Gamecock MOAs/ATCAAs and would continue in the warning areas (W-161 A/B and W-177 A/B). The Air Force also identified two action alternatives, B and C, that comprise subsets of the proposed action but would continue training in the warning areas. For Alternative B, the Air Force would only authorize use of chaff and flares only in the Bulldog A/B MOAs and associated ATCAA. In contrast, authorization would only apply to the Gamecock B/C/D MOAs and associated ATCAA under Alternative C. Both Alternatives B and C would enhance chaff and flare training although to a lesser degree than the proposed action. The no-action alternative (Alternative A), also described in this chapter, reflects the status quo, not authorizing chaff and flare use in the MOAs but continuing it in the warning areas. CEQ regulations (40 CFR 1502.14(d)) require analysis of the no-action alternative.

2.1 DESCRIPTION OF TRAINING CHAFF AND FLARES

Training Chaff. Modern training chaff (RR-188) consists of bundles of extremely small strands of aluminum-coated silica fibers that reflect radio waves from a radar set. Chaff fibers are approximately the thickness of a very thin human hair and range in length from 0.3 to over 1.0 inch (0.76 centimeters to 2.5 centimeters). The length of the chaff determines the frequency range of the radio wave most effectively reflected by that particular filament. This chaff, also known as "angel hair" chaff, is made as small and light as possible so that it will remain in the air long enough to confuse enemy radar. Approximately 5 million chaff strands are dispensed in each bundle of chaff.

When released from an aircraft, chaff initially forms a "puff" that disperses widely in the air. Dispersed chaff forms an electronic cloud that effectively reflects radar signals and forms an image on a radar screen. If the pilot quickly maneuvers the aircraft while momentarily obscured or "masked" from precise radar detection by the electronic cloud, the aircraft can safely maneuver to avoid the threat. When multiple chaff bundles are ejected, each forms a similar cloud that further confuses radar-guided weapons.

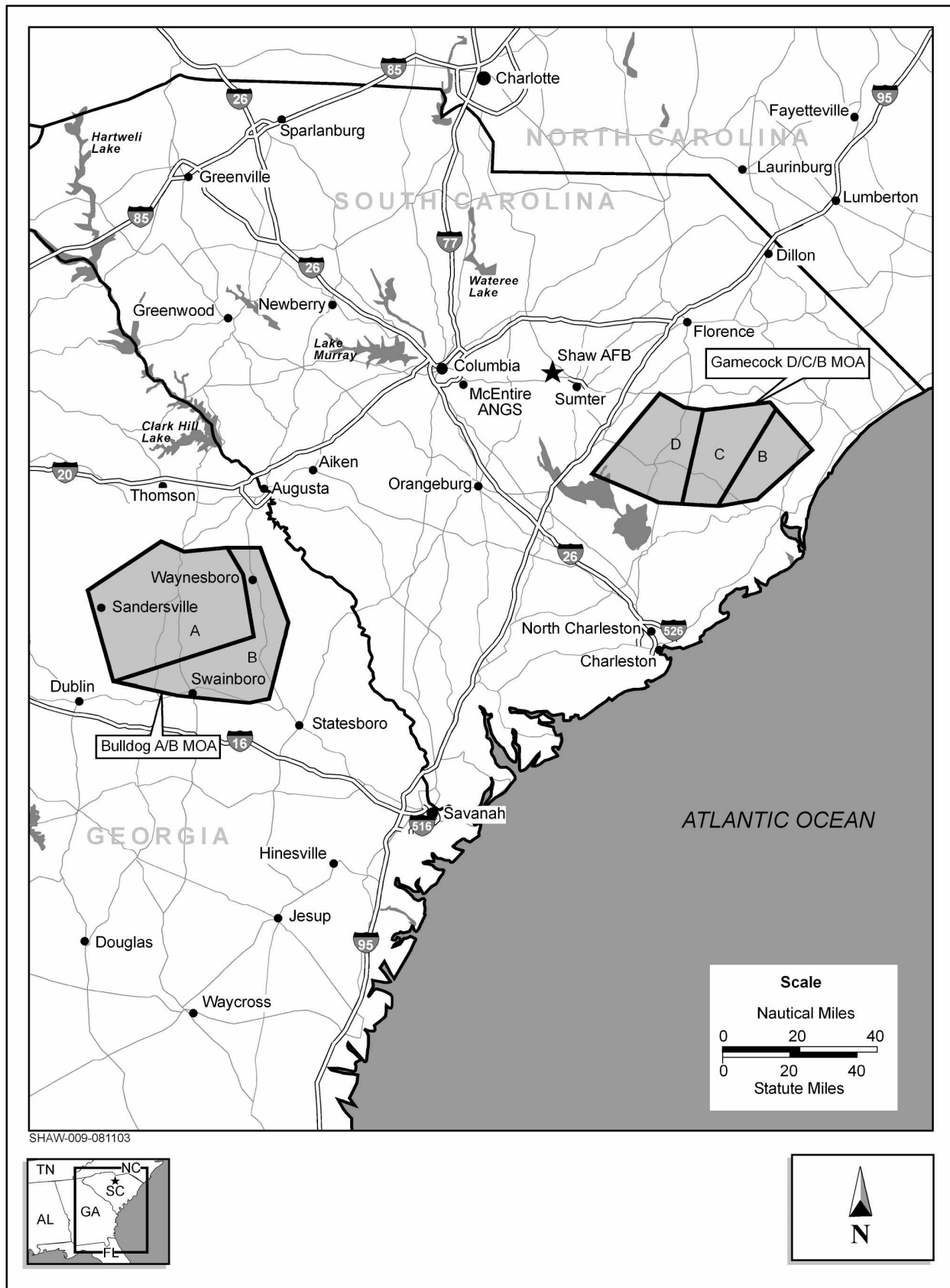
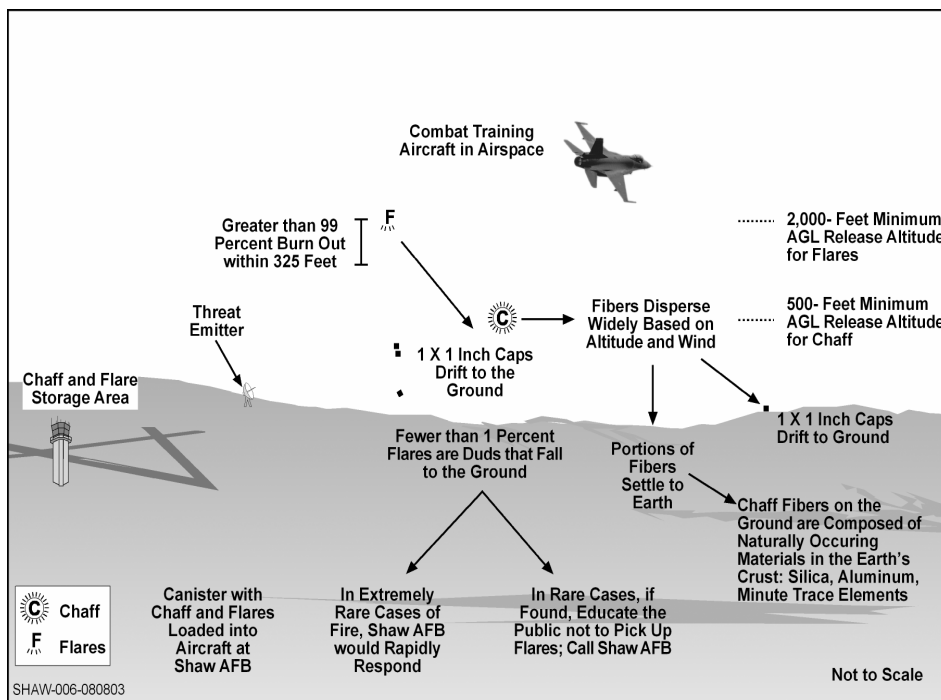

Figure 2-1 MOAs Included in Proposed Action

Chaff itself is not explosive, however, it is ejected from the aircraft pyrotechnically using a small explosive charge that is part of the ejection system. A chaff dispenser remains in the aircraft. Two 1-inch square by 1/8-inch thick pieces of plastic and a felt spacer are ejected with the chaff. On very rare occasions, the chaff may not wholly separate and may fall to earth as a clump.

Chaff used in combat has fibers cut to varying lengths in order to make it effective against the wide range of enemy radar systems that may be encountered. Training chaff proposed for use in the MOA airspace would be limited to RR-188 training chaff that contains fibers cut to lengths that are designed to not interfere with radars operated by the FAA for Air Traffic Control throughout the National Airspace System.

The General Accounting Office (GAO 1998) has reviewed the available information on environmental effects and health risks of chaff, including extensive studies by the Air Force (Air Force 1997). These reviews and studies demonstrate that training chaff poses no significant health risks nor does it adversely affect livestock, wildlife, land use, or visual resources. For more detailed information on chaff, please refer to Appendix A.



Life Cycle of Chaff and Flare Use

sensors targeted on the aircraft. The flares are wrapped with aluminum-filament-reinforced tape and inserted into an aluminum case closed with a felt spacer and a plastic end cap. The top of the case has a pyrotechnic impulse cartridge that is activated electric ally to produce hot gases that push a one 1-inch square by 1/4-inch thick cap and the flare material out of the flare dispenser mounted in the aircraft.

Training Flares.

Defensive training flares are magnesium pellets that, when ignited, burn for a short period (3.5 to 5 seconds) at approximately 2,000 degrees Fahrenheit (1,093 Celsius). The burn temperature is hotter than the exhaust of an aircraft engine and therefore attracts and decoys heat-seeking weapons and

The flare ignites as it is ejected from the dispenser. On extremely rare occasions a flare may not ignite and could fall to the earth as a dud flare. For more detailed information on flares, refer to Appendix B.

ACC (ACC Supplement to Air Force Instruction 11-214) has set minimum flare release altitudes over non-government owned or controlled lands like those under the Bulldog A/B and Gamecock B/C/D MOAs. In such cases, the Air Force restricts flare release to 2,000 feet above ground level (AGL) and above for all aircraft. As described later in this chapter, the lowest altitude proposed for deployment of flares within these MOAs exceeds ACC's minimum by approximately 2,500 feet. Since flares burn out completely within 325 feet after release, the proposed action and action alternatives incorporate an additional safety measure due to limitations on minimum release altitudes. The proposed use of training flares would also incorporate management practices that include the following:

- Flares would not be released over established communities beneath the airspace.
- Flares would not be used at all under high fire conditions or above as defined by the National Weather Service using the National Fire Danger Rating System.
- Cooperation with local agencies for mutual aid response to fires would continue.
- The Air Force would assist local fire departments in an education program about flares.

The following provides an example of a training event illustrating how chaff and flares can be deployed:

- F-16 aircraft are loaded at Shaw AFB with chaff and flares for defensive training. On a typical training mission F-16s carry a mix of 15 chaff bundles and 10 flares (Byers 2003).
- Aircraft take off from the airfield and enter special use airspace to perform low altitude, high-speed navigation training.
- Near the end of this maneuver, the pilot makes a low-altitude, high-speed entry into Restricted Airspace overlying Poinsett Electronic Combat Range (ECR) and performs training in tactical weapons delivery (e.g., strafing or ordnance) and surface attack tactics.
- Upon departing the range target area, the aircraft enters Bulldog A/B MOA with its associated ATCAA. There, opposing aircraft "attack" and participate in air combat tactics training, which incorporates chaff, flares, and air-to-air combat skills.
- Upon completion of this combat training mission, the aircraft return to Shaw AFB.

Under other training scenarios, F-16s would fly directly to a MOA or warning area to complete ACM and/or ACT (for example) and use chaff and flares as part of their defensive countermeasures.

2.2 ALTERNATIVE IDENTIFICATION PROCESSES

To meet the need for defensive chaff and flare training, the Air Force identified the proposed action and action alternatives through application of operational requirements. As listed below, these operational requirements centered on ensuring an alternative met the purpose and need.

1. The airspace must allow pilots to use chaff and flares effectively while conducting training missions with multiple activities. It must also accommodate a wide range of the training events (refer to section 1.2) required for realistic pilot training.
2. In order to enhance training and effectively use training time, the identified airspace must be located in proximity to the bases for the 20 FW and 169 FW. The Air Force has determined that unproductive transit time to and from the training airspace should be 30 minutes or less. At cruising speeds for an F-16, that equates to a distance of about 100 nautical miles (NM) one way.
3. Primary airspace (i.e., airspace managed and scheduled by Shaw AFB) providing 20 FW and 169 FW F-16 pilots with priority use and scheduling is a must. Airspace not managed or scheduled by Shaw AFB but by another service or command would increase the existing problem of airspace availability and training cancellations for the 20 FW and 169 FW pilots. Such cancellations translate into losses of valuable, finite training time.
4. To accommodate ground-based assets that simulate enemy threats (e.g., electronic emitters), the airspace must overlie land. Overland versus overwater airspace also provides greater realism for the Air Force training missions and tactics.

The result of the evaluation process identified the Bulldog A/B MOAs as well as the Gamecock B/C/D MOAs meeting the operational requirements for the 20 FW and 169 FW chaff and flare training. These MOAs (and associated ATCAAs) correlate well to each one of the requirements because:

- Both sets of MOAs already accommodate most if not all of the air-to-air and air-to-ground training events (except actual ordnance delivery) required by the F-16 pilots for realistic combat-like training.
- The sets of MOAs lie within 100 NM of Shaw AFB and McEntire ANGS, thereby assuring pilots of sufficient training time.
- Shaw AFB manages and schedules all the Bulldog and Gamecock MOAs, ensuring that the 20 FW and 169 FW receive priority use and scheduling.
- These overland airspace units are linked to ground-based threat emitter assets that enhance realism in training.

Within 100 NM of Shaw AFB and McEntire ANGS, no other airspace units meet the operational requirements. For example, the airspace associated with Poinsett ECR lacks the horizontal size necessary to support most of the F-16 training events realistically and effectively. Despite the presence of threat emitters on Poinsett ECR, the limitations on the airspace preclude realistic responses by pilots for the

types of threats expected in combat. Other MOAs within the area either lack the vertical or horizontal size, or are managed and scheduled by other services or units. Similarly, the overwater warning areas fail to meet all the requirements. While these areas provide opportunities for valuable and extensive training for the 20 FW and 169 FW, they lack the realistic threat environment and suffer from cancellations of training due to inclement weather.

2.3 PROPOSED ACTION AND ALTERNATIVES

The Air Force determined that only the Bulldog A/B and Gamecock B/C/D MOAs fulfill the purpose and need for the proposed action. Therefore, the Air Force developed the proposed action and action alternatives around the use of those MOAs. A total of four alternatives were carried forward for detailed analysis:

- **Proposed Action** – Authorize use of chaff and flares in the Bulldog A/B MOAs and overlying ATCAA and in the Gamecock B/C/D MOAs and overlying ATCAA; continue use of chaff and flares in warning areas W-161 A/B and W-177 A/B (refer to Figure 2-1).
- **Alternative A No-Action** – Do not authorize use of chaff and flares in the Bulldog or Gamecock MOAs, but continue current chaff and flare use in warning areas W-161 A/B and W-177 A/B.
- **Alternative B** – Authorize use of chaff and flares in the Bulldog A/B MOAs and overlying ATCAA only; continue use of chaff and flares in warning areas W-161 A/B and W-177 A/B (Figure 2-2).
- **Alternative C** – Authorize use of chaff and flares in the Gamecock B/C/D MOAs and overlying ATCAA only; continue use of chaff and flares in warning areas (Figure 2-3).

Because the same airspace units are involved, the following presents the components and aspects of the proposed action and each alternative in comparative fashion. No aspect of the proposal would affect operations or activities at Shaw AFB and McEntire ANGS, so these areas receive no further attention in this discussion.

2.3.1 Airspace Structure and Use

The MOAs forming part of the proposed action and alternatives overlie portions of eastern South Carolina (Gamecock) and northeastern Georgia (Bulldog). These MOAs provide extensive maneuvering airspace both horizontally (Figure 2-1) and vertically (Table 2-1). Floor (lower) and ceiling (upper) altitudes for these MOAs and associated ATCAAs range from 100 feet AGL to 27,000 feet MSL. No aspect of the proposed action or alternatives would alter the existing structure of the MOAs or the amount of use they receive. Discussion of these aspects of the airspace provides, however, a context for understanding the proposed use of chaff and flares and aids in defining the affected environment.

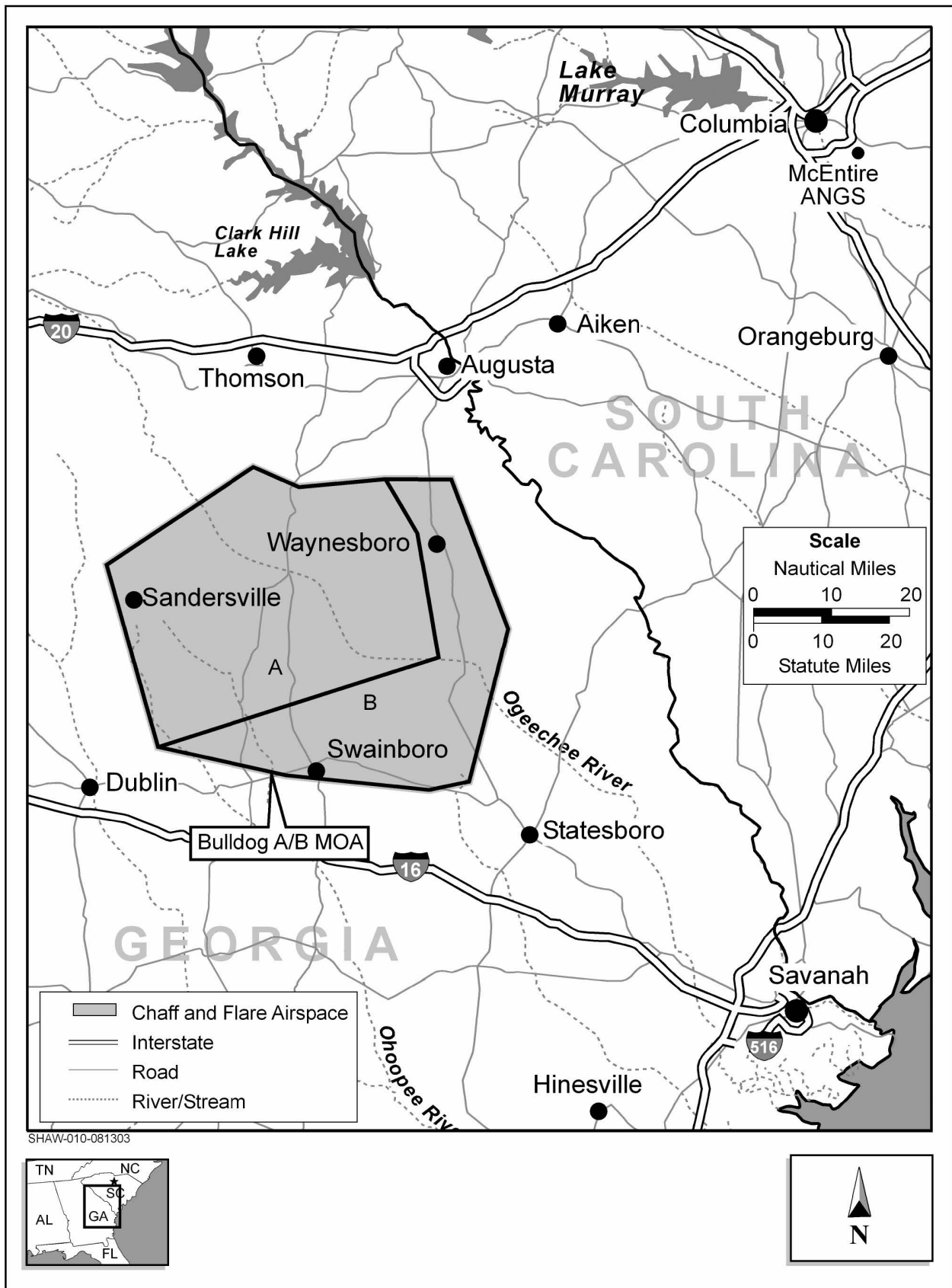

Figure 2-2 Alternative B – Proposed Chaff and Flare Airspace

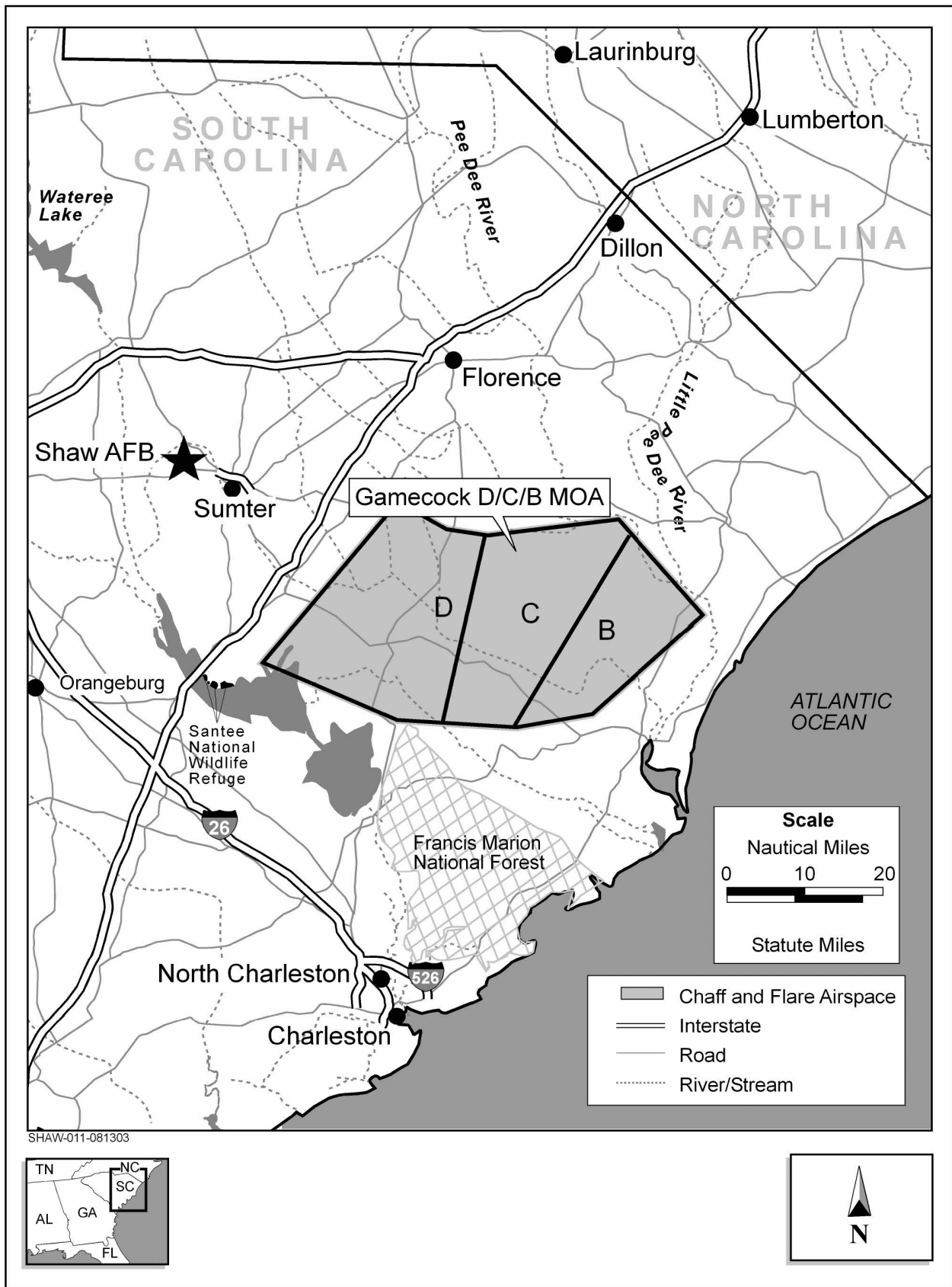

Figure 2-3 Alternative C – Proposed Chaff and Flare Airspace

Table 2-1 Altitude Structure of MOAs and ATCAAs			
<i>MOA</i>	<i>Floor (feet)</i>	<i>Ceiling (feet)</i>	<i>Notes</i>
Bulldog A	500 AGL	9,999 MSL	Scheduled and used in conjunction with overlapping Bulldog B
Bulldog B	10,000 MSL	17,999 MSL	Scheduled and used in conjunction with underlying Bulldog A; overlaps A completely
“Bulldog” ATCAA	18,000 MSL	27,000 MSL	Overlies Bulldog B
Gamecock B	10,000 MSL	17,999 MSL	Overlaps eastern half of Gamecock C; operational only 4 weeks per year
Gamecock C	100 AGL	9,999 MSL	Underlies Gamecock D in western half and Gamecock B in eastern half
Gamecock D	10,000 MSL	17,999 MSL	Overlies western half of Gamecock C and extends further westward
“Gamecock” ATCAA	18,000 MSL	22,000 MSL	Overlies portions of both Gamecock B and Gamecock D

The Bulldog A/B MOA and ATCAA comprise a set of interrelated airspace units commonly scheduled and used together. Bulldog A, the lower altitude MOA, completely underlies the larger Bulldog B MOA. As the higher altitude MOA, Bulldog B’s horizontal boundaries extend well east of the limits of underlying Bulldog A. Both of these MOAs operate from 7:00 am to 10:30 pm daily, providing training opportunities for aircraft ranging from F-16s to KC-135 tankers to T-38 trainers. Per agreement, the FAA activates the ATCAA overlying Bulldog B MOA per request as long as it does not interfere with other aviation.

Similarly, the Gamecock B/C/D MOAs and ATCAA also consist of linked airspace units. Gamecock C underlies a portion of both Gamecock B and D and these MOAs may be activated from 8:00 a.m. until midnight. In contrast, the Gamecock B is used only 4 weeks per year (no more than 2 weeks consecutively) for exercises that also extend into the other two MOAs. Activation of the ATCAA overlying Gamecock D MOA occurs whenever Gamecock D MOA is activated and is used in conjunction with Gamecock D MOA. Aircraft commonly using this set of MOAs include F-16s, F-14s, A-10s, F-18s, F-15s, and T-1s.

Warning areas W-161 A/B and W-177 A/B lie off the South Carolina coast. Extending from the surface up to a maximum altitude of 62,000 feet MSL, these expansive warning areas cover a total of about 4,500 square NM and support training by aircraft including F-16s, F-14s, A-10s, F-18s, F-15s, C-130s, C-141s, C-17s, helicopters, tankers, and trainers.

Sortie-operations by the 20 FW dominate baseline use of the MOAs (Air Force 2002 [Force Structure Change EA]). A sortie-operation is the use of one airspace unit by one aircraft; if an F-16 flies through two MOAs, it would generate two sortie-operations. Of the 6,658 annual baseline sortie-operations in the Bulldog A/B MOAs (and ATCAA), F-16s from the 20 FW account for 84 percent (5,589). Similarly, the

20 FW contributes 73 percent (3,385) of the 4,608 total annual baseline sortie-operations in the Gamecock D MOA. In the Gamecock C MOA, the 20 FW contributes 19 percent (788) of the total annual sortie-operations (4,236). For Gamecock B MOA, exercises include numerous aircraft types and the amount of sortie-operations varies annually based on the nature of the exercises. Within all of the MOAs, roughly 1 percent of the baseline sorties by F-16s occur after 10 pm at night. Within the warning areas, the 20 FW flies approximately 4,400 baseline sortie-operations annually.

Neither the proposed action nor the alternatives would result in any change to the number of sortie-operations conducted by the 20 FW and 169 FW within the MOAs or warning areas. Proposed chaff and flare deployment would occur as part of the regular sortie-operations in the airspace. Moreover, the flight profiles and altitude distribution of the sortie-operations would not change from baseline conditions.

2.3.2 Flare and Chaff Use

Table 2-2 presents the annual average chaff and flare use under the proposed action and alternatives. Alternative A, no-action, equates to baseline conditions against which the other alternatives are compared. The 20 FW and 169 FW based estimates of proposed chaff and flare use for the Bulldog A/B and Gamecock C/D MOAs on the following factors:

- 15 chaff bundles and 10 flares per aircraft,
- 4 aircraft per training mission,
- 4 training missions per day (3 by 20 FW and 1 by 169 FW), and
- 5 days per week, 4 weeks per month, and 12 months per year.

<i>Alternative</i>	<i>Bulldog A/B MOAs/ATCAA</i>	<i>Gamecock B MOA</i>	<i>Gamecock C/D MOAs/ATCAA</i>
	<i>Chaff/Flares</i>	<i>Chaff/Flares</i>	<i>Chaff/Flares</i>
Proposed Action	57,600/38,400	4,800/3,200	57,600/38,400
A: No-Action (Baseline)	0/0	0/0	0/0
B: Bulldog MOAs	57,600/38,400	0/0	0/0
C: Gamecock MOAs	0/0	4,800/3,200	57,600/38,400

Since operations in the Gamecock B MOA are limited to 4 weeks per year, use of chaff and flares would equate to 1/12th (1 month) of the annual average estimate. Usage in each of the warning areas would continue at baseline levels which represent 50 percent of the amount of chaff and flares proposed for either the Bulldog A/B MOAs or Gamecock C/D MOAs.

The proposed chaff and flare use levels for the MOAs reflect an estimate based on year-round training by the 20 FW and 169 FW in the region. As noted in Chapter 1, these combat units deploy as part of an AEF. Such deployments can last 90 days or longer, thereby reducing total annual training activities in the

MOAs and warning areas. A commensurate decrease in chaff and flare use would also result from the deployment.

Proposed minimum altitudes for deploying flares during training in the MOAs and ATCAAs will exceed those established by the Air Force (2,000 feet AGL) over nongovernment-owned or controlled lands. For the Bulldog A/B MOAs, the minimum release altitude of 5,000 feet MSL would be 3,000 feet above the Air Force minimum for flares. Similarly, minimum altitudes of 5,000 and 10,000 feet MSL for the Gamecock MOAs equate to 4,500 to 8,500 feet AGL (respectively), well above the minimum altitude. Moreover, F-16 pilots from the 20 FW and 169 FW will continue to fly through the entire vertical extent of the airspace, so chaff and flares would be released within that full range of altitudes, at a minimum of 5,000 feet MSL.

<i>MOA/ATCAA</i>	<i>Operational Altitudes</i>		<i>Proposed Minimum Altitudes for Chaff and Flares</i>
	<i>Floor (feet)</i>	<i>Ceiling (feet)</i>	<i>(in feet)</i>
Bulldog A/B and ATCAA	500 AGL	27,000 MSL	5,000 MSL
Gamecock B	10,000 MSL	18,000 MSL	10,000 MSL
Gamecock C	100 AGL	9,999 MSL	5,000 MSL
Gamecock D and ATCAA	10,000 MSL	22,000 MSL	10,000 MSL

The proposed minimum release altitudes would apply to the proposed action as well as Alternatives B and C. Under Alternative A, no-action, use of chaff or flares would not be authorized in the MOAs and ATCAAs. Use in the warning areas for which no minimum altitudes apply will continue unchanged.

2.4 ENVIRONMENT IMPACT ANALYSIS PROCESS

This EA examines the affected environment for each alternative and analyzes the environmental consequences associated with authorizing chaff and flare use, along with the impacts of the no-action alternative. The following steps were undertaken in preparation of the EA for this proposed action:

1. *Conduct Interagency and Intergovernmental Coordination for Environmental Planning (IICEP).* Within this process comments are solicited from the public in the region local to the proposed action and action alternatives. This includes those individuals who have expressed interest in activities emanating from Shaw AFB, local governments, federal and state agencies, and interest groups to ensure their concerns and issues about the proposal are included in the analysis. In July 2003, the Air Force sent IICEP letters (Appendix C) to these individuals and agencies announcing the Air Force's proposed action and to request input from government agencies (Appendix D).
2. *Prepare a draft EA and draft Finding of No Significant Impact (FONSI).* The first comprehensive documents for public and agency review are the draft EA and FONSI. The draft EA examines the environmental impacts of the proposed action as well as the action and no-action alternatives. The draft FONSI presents the finding of no significance based on the impact analysis, if warranted.

3. *Announcement that the draft EA and FONSI have been prepared.* An advertisement, in the papers local to the proposed action, was posted notifying the public as to the draft EA and FONSI availability for review in local libraries. The public notice of document availability was published in the following newspapers: Florence County Morning News, The Item, The Sun News, Manning Times, Signal, The Augusta Chronicle, and Shaw Spirit. After the draft EA and FONSI were distributed, a 30-day public comment period commenced.
4. *Provide a public comment period.* Our goal during this process is to solicit comments concerning the analysis presented in the draft EA and FONSI. The public comment period extended from October 15, 2003 through November 17, 2003. Comments were received from the Georgia State Clearinghouse. The Georgia State Historic Preservation Office sent a response indicating no issues to the proposed action and alternatives and special status species information for the federally listed wood stork was provided by the Coastal Georgia Field Office of the USFWS. No comments were received from the South Carolina State Historic Preservation Office or other agencies (Appendix D).
5. *Prepare a final EA and issue a final FONSI.* Following the public comment period, a final EA is prepared. This document is a revision (if necessary) of the draft EA. It includes consideration of public and agency comments, and provides the decisionmaker with a comprehensive review of the proposed action as well as action and no-action alternatives and the potential environmental impacts. A FONSI is provided documenting the conclusion of no significant impact, if warranted. The final EA and FONSI availability are then announced in the same newspapers as the draft EA and FONSI.

2.5 OTHER REGULATORY AND PERMIT REQUIREMENTS

In accordance with the Endangered Species Act and the National Historic Preservation Act, the Air Force has initiated informal consultation with the United States Fish and Wildlife Service and with the State Historic Preservation Officers in South Carolina and Georgia. (Note to readers: information will be added based in response to letter received).

2.6 MITIGATION MEASURES

In accordance with 32 CFR 989.22, the Air Force must indicate if any mitigation measures would be needed to implement the proposed action or any alternative selected as the preferred alternative under this environmental assessment. However, no mitigation measures would be needed to arrive at a finding of no significant impact if the proposed action or any action alternatives were selected for implementation under this chaff and flare proposal in Shaw AFB training airspace.

2.7 SUMMARY OF ENVIRONMENTAL CONSEQUENCES

According to the analysis in the EA, implementation of the proposed action or alternatives would not result in significant impacts to any resource category. Deployment of chaff and flares in the Bulldog A/B and Gamecock B/C/D MOAs would not significantly affect existing conditions in the lands under the MOAs. The following summarizes and highlights the results of the analysis by resource category.

Land Management, Use, and Recreational Resources. Impacts to the use and management of lands underlying the MOAs in the affected environment would be insignificant. Chaff and flare residual components are not expected to accumulate on soil or water surfaces or change the chemistry of soil or water properties. Therefore, management and use of the lands underlying the MOAs would not change from existing conditions. Recreational resources may be negligibly affected due to rare sightings of chaff or flare residual components (i.e., end caps). Therefore, implementation of either the proposed action or action alternatives would have negligible effects to land management, use, and recreational resources.

Biological Resources. Based on the non-toxicity of chaff and the remote risk of fire from flares, the effects on vegetation, wildlife, and special-status species would be negligible. Impacts to wildlife from startle effect would not be expected due to the high altitude (over 5,000 feet MSL) of flare deployment. Wetlands are not expected to be impacted by residual components of chaff and flares or dud flares due to the large size of the MOAs used for deployment and the extremely low potential for accumulation of components in any one area. No impacts to these resources are expected under the proposed action and action alternatives.

Soils and Water. Potential impacts to soils and water resources would be negligible because chaff fibers and flare ash would not accumulate to any extent on the surface of these resources. Any accumulation of materials on soil surfaces would be quickly dissolved due to the humid conditions and acidity of the soils. The probability of dud flares accumulating in water resources or a burning flare reaching the ground to ignite a fire is remote given the reliability of flare burn design, advanced deployment systems and high altitude of deployment. Therefore, impacts to these resources would be minimal under the proposed action and action alternatives.

Safety. The reliability of chaff and flare deployment systems and flare burn design would result in minimal potential safety impacts to the public. RR-188 training chaff does not interfere with FAA radar control systems and has been approved for use in airspace by the FAA. Flares have been designed to completely burn out within 325 feet of release and under this proposal flares would be released at approximately 5,000 feet MSL, leaving an extensive safety margin to prevent any burning materials from reaching the ground. Likewise, the probability of dud flares is extremely low and such rare occurrences would be dispersed across a wide region. As such, insignificant impacts would be expected from dud flares coming to rest on the ground. The Air Force would also coordinate with local fire and safety

officials to educate the public about avoiding any dud flares. Therefore, no significant impacts are anticipated if the proposed action or action alternatives were implemented.

Materials Management. Minimal impacts to this resource would be expected because storage facilities at Shaw AFB and McEntire ANGS are capable of handling the increased inventories of chaff and flares and procedures exist for processing and handling the materials at both locations. The wide dispersal and low probability of accumulation of chaff and flare residual components under the MOAs would result in negligible effects to the environment. Implementation of the proposed action and action alternatives would result in no changes to existing handling procedures of chaff and flare inventories.

Environmental Justice. No impacts to low-income and minority populations would be anticipated. No changes to current flight levels or flight activities in the MOAs with the potential to affect noise levels would occur under the proposed action or alternatives. Chaff and flares would be widely dispersed throughout the MOAs resulting in no one community or population being disproportionately affected. Therefore, no significant or disproportionate impacts would be expected through implementation of the proposed action or action alternatives due to chaff and flare deployment.

CHAPTER 3

DESCRIPTION OF THE AFFECTED ENVIRONMENT AND ENVIRONMENTAL CONSEQUENCES

CHAPTER 3

DESCRIPTION OF THE AFFECTED ENVIRONMENT AND ENVIRONMENTAL CONSEQUENCES

3.1 ANALYSIS APPROACH

The National Environmental Policy Act (NEPA) requires focused analysis of the areas and resources potentially affected by an action or alternative. An EA also considers, but does not analyze in detail, those areas or resources not affected by the proposal. An EA should not be encyclopedic; rather, it should be concise and scientifically-based. This EA, therefore, focuses on those resources that would be affected by proposed chaff and flare use in the Bulldog A/B and Gamecock B/C/D MOAs.

CEQ regulations (40 CFR Parts 1500-1508) for NEPA also require an EA to discuss impacts in proportion to their significance and present only enough discussion of other than significant issues to show why more study is not warranted. The analytic approach this EA takes considers the current conditions of the affected environment and compares those to conditions that might occur should any of the alternatives be implemented. Because an extensive description of the underlying affected environment for Bulldog A/B and Gamecock B/C/D MOAs is provided in the *Final Environmental Assessment Utilization of Shaw Air Force Base Managed Airspace* (Shaw AFB 2001) and the *Final Environmental Assessment for Force Structure Change at Shaw Air Force Base* (Air Force 2002), this EA limits such description. In addition, the analysis used the *Final Report of Environmental Effects of Self-Protection Chaff and Flares* (Air Force 1997) extensively to evaluate the effects of chaff and flares to the environment.

Resources Analyzed

Table 3-1 presents the results of the process of identifying resources considered in this EA. This assessment evaluates biological resources, soils and water, safety, materials management, environmental justice, as well as land management, use, and recreational resources. These resources have shown to be potentially affected by the proposed action and alternatives.

Table 3-1 Resources Analyzed in the Environmental Impact Analysis Process		
<i>Resource</i>	<i>Potentially Affected by Chaff and Flare Deployment</i>	<i>Analyzed in this EA</i>
Land Management, Use, and Recreational Resources	Yes	Yes
Biological Resources	Yes	Yes
Soils and Water	Yes	Yes
Safety	Yes	Yes
Materials Management	Yes	Yes
Environmental Justice	Yes	Yes
Air Quality	No	No
Airspace	No	No
Cultural Resources	No	No
Hazardous Materials/Hazardous Waste	No	No
Noise	No	No
Socioeconomics	No	No
Transportation	No	No
Visual	No	No

Resources Eliminated from Further Analysis

The Air Force assessed numerous resources (refer to Table 3-1) that, in accordance with CEQ regulations, warranted no further examination in the EA. The following describes the rationale for this approach.

Air Quality. Air quality would not be affected by the proposed action or alternatives. All of the counties underlying the Bulldog A/B and Gamecock B/C/D MOAs are within attainment areas for national and local air quality standards (USEPA 2003). There will be no changes in the number of aircraft operations or the altitude regime in which they operate, nor will emissions from chaff and flare deployment produce any measurable additions to criteria pollutants (carbon monoxide, particulate matter [PM₁₀ and PM_{2.5}], sulfur dioxide, ozone, lead, and nitrogen oxide) in the region (Air Force 1997). Currently, only PM₁₀ is regulated for particulate matter but the Environmental Protection Agency is considering standards for PM_{2.5}. However, chaff and flare deployment would not emit particulate matter less than PM₁₀ in size.

Airspace. Airspace management and use would not be affected by the proposed action or any of the alternatives. Sortie-operations within the Bulldog A/B and Gamecock B/C/D MOAs would remain unchanged from those presented in the Airspace Utilization EA (Shaw AFB 2001) and no modifications to the size or manner of use of these airspace units would occur. Proposed use of chaff and flares would not affect civil aviation or Federal Aviation Administration (FAA) operations in the areas around the MOAs. The type of chaff to be deployed would not affect FAA radars. Therefore, no impacts would occur to airspace if the proposed action or alternatives were implemented.

Cultural Resources. Under the proposed action and alternatives existing aircraft operations would remain the same. Chaff and flare deployment would not affect archaeological resources (Air Force 1997), and architecturally-significant structure impacts would only occur if there was a fire ignition from a dud flare. However, the probability of flare ignition (refer to section 3.5, Safety) would be extremely minimal and not pose any significant impacts to structures. Tribal entities associated with the lands underlying the airspace have not identified any impacts to traditional resources under the proposed action or alternatives. Therefore, existing conditions would continue and further analysis of this resource is not carried forward in this EA.

Hazardous Materials and Waste. Effects from hazardous materials and waste would be negligible to nonexistent. The components in chaff and flares do not comprise hazardous materials or waste. Thus, any residues contacting the ground after deployment would not introduce hazardous materials or waste into the environment. Adherence to existing policies relating to hazardous materials management, storage, and use would be undertaken and monitored under the Air Force's Environmental Compliance Assessment Management Program, which requires both internal audits and examination by independent reviewers. Given the enforced requirement to ensure safe handling of materials, the minimal amounts of materials likely to be used, and the lack of impacts from residues, the probability for an effect on the environment would be so negligible that further analysis in this EA is unwarranted.

Noise. The proposed action would not change the local noise environment to those areas underlying Bulldog A/B and Gamecock B/C/D MOAs. Aircraft would continue to undertake missions as described in the Authorized Managed Airspace EA (Air Force 2001) and the noise they generate would not change if the proposed action or alternative were chosen. Therefore, this resource was not analyzed to any further extent within this EA.

Socioeconomics. This resource would not be affected by implementation of the proposed action or alternatives. Chaff and flare deployment would not change the local, regional, or statewide economics or social conditions of either South Carolina or Georgia. Therefore, further analysis of this resource is not undertaken.

Transportation. Under the proposed action and alternatives, transportation would not be affected by chaff and flare deployment. No increase to local traffic would occur and effects of the proposed action and alternatives on existing transportation resources would not be measurable or noticeable.

Visual Resources. Visual resources would not be affected by chaff and flare deployment. Chaff fibers are so small and dispersed over such a wide area that visual detection would be virtually impossible (refer to section 3.2, Land Management, Use, and Recreational Resources). Flares would appear as temporary flashes in the sky and be dispersed over a large area both vertically and horizontally. Therefore, both

chaff and flares would not represent significant effects to the visual environment found in the Bulldog A/B and Gamecock B/C/D MOAs and not carried forward for further analysis.

3.2 LAND MANAGEMENT, USE, AND RECREATIONAL RESOURCES

Land use generally refers to human modification of land, often for residential or economic purposes. It also refers to the use of land for preservation or protection of natural resources such as wildlife habitat, vegetation, or unique features. Human land uses include residential, commercial, industrial, agricultural, and recreation. Unique natural features are often designated as national or state parks, forests, wilderness areas, or wildlife refuges.

Attributes of land use include general land use and ownership, land management plans, and special use areas. Land ownership is a categorization of land according to the type of owner. Major land ownership categories include federal, state, American Indian, and private. Federal lands are further defined by the managing agency, which may include the U.S. Fish and Wildlife Service, U.S. Forest Service, Bureau of Land Management, or the DoD. Land uses are frequently regulated by management plans, policies, ordinances, and regulations that determine the types of activities that are allowed or that protect specially designated or environmentally sensitive uses. Special Use Land Management Areas (SULMAs) are identified by federal and state agencies as being worthy of more rigorous management. Recreational resources include evaluation of the potential effects to activities such as swimming, boating, hiking, and fishing and the lands that support these activities.

The affected environment for land management, use, and recreation consists of those areas under and immediately adjacent to the Bulldog A/B MOAs in Georgia and Gamecock B/C/D MOAs in South Carolina. This analysis focuses on the potential effects of chaff and flare use consisting of accumulation of chaff and flare debris and observance of flare deployment.

Affected Environment

Bulldog A/B MOAs overlies portions of Washington, Jefferson, Burke, Johnson, Emanuel, and Jenkins counties in the mideastern section of Georgia. The land area under the MOAs covers approximately 2,728 square NM (USGS 2001), with primary land uses consisting of agriculture, forestry, and small rural communities (Figure 3-1). The City of Augusta, located approximately 25 miles outside the northeastern border of Bulldog B MOA is the largest city adjacent to the MOA. Numerous, sparsely populated communities are scattered throughout the counties under the MOAs.

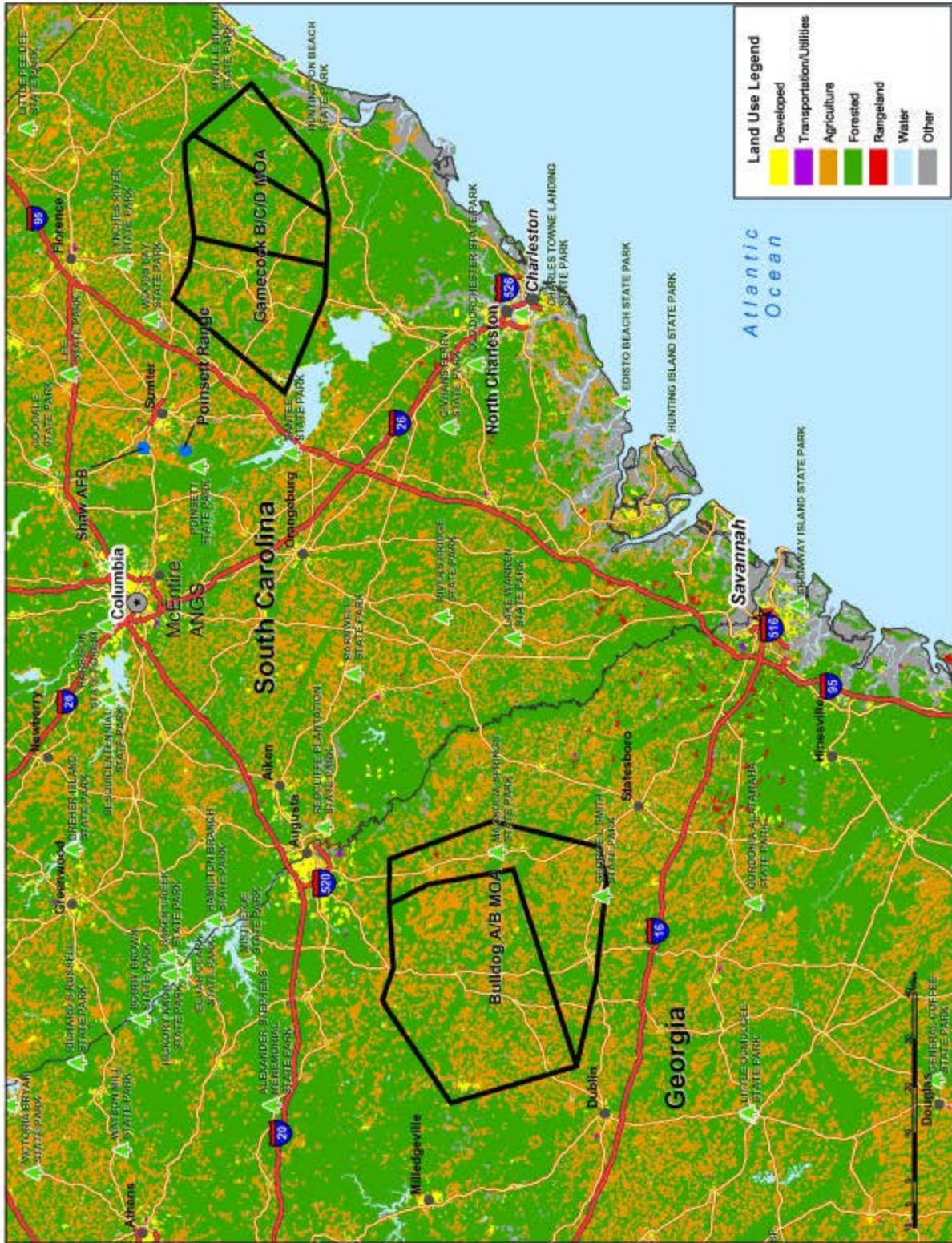

Figure 3-1 Existing Land Uses Under Bulldog A/B and Gamecock B/C/D MOAs

Magnolia Springs State Park in Millen County and George L. Smith State Park in Emanuel County are under the Bulldog B MOA (GSP 2003). The parks offer camping, hiking, fishing, swimming, picnicking, and boating recreational opportunities. Nearly 50 miles of the 245-mile Ogeechee River flows under the center of the training airspace and approximately 30 miles of the Ohoopsee River (Little Ohoopsee) flows under the western portion of the MOA (refer to Figure 2-2). Both rivers provide numerous recreational opportunities (GWR 2003). The southern perimeter of Fort Gordon Military Reservation lies under the northern border of Bulldog A/B MOAs.

Gamecock B/C/D MOAs overlies approximately 1,684 square NM of Florence, Marion, Clarendon, Berkeley, Williamsburg, and Georgetown counties in the upper east portion of South Carolina (USGS 2001). Primary land uses under the Gamecock MOAs, include agriculture, forestry, and rural communities (refer to Figure 3-1). Numerous, sparsely populated communities are scattered throughout the counties under the MOAs. The City of Columbia lies approximately 50 miles outside the western edge of Gamecock D MOA.

Portions of Lake Marion and the Santee River occur under the southern extreme of Gamecock D MOA. Lake Marion, the largest lake in South Carolina, and the Santee River provide many recreational opportunities for tourists and local residents. Fishing is the most popular sport on both water bodies (SCL 2003). The Santee National Wildlife Refuge (NWR) and Francis Marion National Forest are located 5 to 7 miles southwest and south, respectively, beyond the limits of the Gamecock D MOA boundary (refer to Figure 2-3).

Environmental Consequences

Proposed Action

The deployment of chaff and flares in the Bulldog A/B and Gamecock B/C/D MOAs would have little impact to land management, use, and recreational resources on the lands underlying the airspace. Chaff and flares would not change the manner in which lands are managed or used. Impacts to crops and forest flora would be considered negligible because chaff debris would not affect the growth of plants or trees and has been shown to have very little effect on soil, air, and water upon which the flora depend (Air Force 1997). The concentration of flare ash would be considered insignificant given the large area of dispersment and the potential for fire ignition from flares is considered miniscule due to the high altitude of deployment and the reliability of the flare burn design. Therefore, chaff and flare deployment would have negligible impact to land use and management if the proposed action were implemented.

Recreational resources would not be adversely affected by chaff and flare deployment in the overlying MOAs. It is possible for chaff and flare debris to accumulate on plants and trees in areas of high use, however, studies have shown that landscapes with varied surface coloration (i.e., leaves, grasses, soils, and twigs) such as that found in Georgia and South Carolina reduce the visibility of chaff fibers and

debris associated with chaff and flares (Air Force 1997). Additionally, collection of chaff and flare residual components in any one area is remote given the large training space of the MOAs. Moreover, field studies indicate that chaff and flare debris do not significantly affect the aesthetic quality of various environmental settings since wind and rain contribute to the dispersement of fibers and debris in general does not tend to accumulate in noticeable quantities in any one area (Air Force 1997). During the day, flare deployment would scarcely be noticeable since only a small puff of smoke is associated with the burning flare. At night, the burning flare could be momentarily mistaken for a shooting star. Given these negligible effects, recreational resources and their use would not change should the proposed action be implemented.

Alternative A: No-Action

Under the no-action alternative, Shaw AFB 20 FW and McEntire ANGS 169 FW would not deploy training chaff and flares in the Bulldog A/B and Gamecock B/C/D MOAs. Airspace operations in the MOAs would continue without the use of chaff and flares. Under this alternative, there would be no change in existing conditions and minimal ongoing effects to land management, use, and recreational resources would continue.

Alternative B: Chaff and Flare Deployment in Bulldog A/B MOAs Only

Implementation of Alternative B would have an insignificant impact to land management, use, or recreational resources under Bulldog A/B MOAs. As discussed under the proposed action, deployment of chaff and flares in the MOAs would not adversely affect soil and water properties that support the flora, therefore, no direct or indirect affects to agricultural crops or forest resources would be expected. Due to the altitude of flare deployment and size of the MOAs, impacts to recreational resources would be minimal.

Alternative C: Chaff and Flare Deployment in Gamecock B/C/D MOAs Only

Chaff and flare deployment in the Gamecock MOAs would not adversely affect land management, use, or recreational resources. As discussed under the proposed action, chaff and flare residual components are not expected to impact agricultural crops or forest. Recreational resources would not be affected from chaff and flare residual components given the size of the training airspace and related dispersal of debris, the varied landscape surface colorations, and low potential for accumulation in any one area. Therefore, implementation of Alternative C would result in negligible impacts to these resources.

3.3 BIOLOGICAL RESOURCES

Biological resources encompass plant and animal species and the habitats within which they occur. Plant species are often referred to as vegetation and animal species are referred to as wildlife. Habitat can be defined as the area or environment where the resources and conditions are present that cause or allow a plant or animal to live there. Biological resources for this EA include vegetation, wildlife, and special-

status species that may occur in the region underneath and immediately adjacent to the Bulldog A/B MOAs in Georgia and Gamecock B/C/D MOAs in South Carolina (refer to Figure 1-1). Biological resources could be directly affected by residual components from chaff and flares (i.e., fibers, end caps, dud flares, etc.) or wildlife and special-status species could be startled by flare deployment. Potential indirect affects include damage to habitat due to potential fires.

Affected Environment

Vegetation. Vegetation includes all existing terrestrial plant communities with the exception of special-status species. The lands under and adjacent to the Bulldog A/B and Gamecock B/C/D MOAs consist mostly of southeastern evergreen forest although the regional lands are considered part of the deciduous forest formation, as both communities exist in the region. Much of the vegetation in the region has been impacted and modified through farming, timber production, and urban development (Shaw AFB 2001).

The southeastern evergreen forest is restricted to the Coastal Plain of the Atlantic and Gulf states. Longleaf pine and loblolly pine are the predominant species. Hardwood forests, generally found in forest communities dominated by loblolly pine, include oaks, hickory, sweet gum, sour gum, red maple, and ash. Hardwood forests occurring along river bottomlands consist of sweet gum, cottonwood, white ash, elm, sycamore, hackberry, oak, and maple species. Swamps and wetlands are common in the Coastal Plain and Gulf states and harbor a variety of tree and grass species including pond cypress, bald cypress, pond pine, swamp tupelo, water tupelo, overcup oak, and water hickory (Shaw AFB 2001).

Wildlife. Wildlife includes all animals (i.e., fish, amphibians, reptiles, birds, and mammals) with the exception of those identified as domesticated livestock or special-status species. A diversity of wildlife species occurs in the regions underlying the Bulldog A/B and Gamecock B/C/D MOAs. Common reptile and amphibian species include marbled salamander, gray treefrog, eastern spadefoot, green anole, slider, common garter snake, and coachwhip. Some of the most common bird species include turkey vulture, red-tailed hawk, great horned and barred owl, hairy woodpecker, osprey, blue jay, common yellowthroat, hooded warbler, summer tanager, northern mockingbird, great blue heron, and waterfowl such as red-throated loon, Canadian goose, wood duck, northern shoveler, northern pintail, gadwall, green-winged teal, and mallard. Common mammals include eastern fox squirrel, eastern cottontail, Virginia opossum, white-tailed deer, river otter, muskrat, raccoon, red and gray fox, and striped skunk.

Special-Status Species. Special-status species are defined as those plant and animal species listed or proposed for listing as threatened and endangered by the USFWS. Threatened and endangered species may occur adjacent to or beneath the Bulldog A/B and Gamecock B/C/D MOAs. Specifically, the following threatened and endangered species are known to occur underneath the Bulldog A/B MOAs: Canby dropwort, flatwoods salamander, eastern indigo snake, gopher tortoise, bald eagle, red-cockaded woodpecker, and wood stork (GADNR 2003). The following threatened and endangered species are

known to occur underneath the Gamecock B/C/D MOAs: Canby dropwort, chaffseed, pondberry, seabeach amaranth, pool sprite, shortnose sturgeon, flatwoods salamander, bald eagle, wood stork, and red-cockaded woodpecker (SCDNR 2003). Big Dukes Pond, a depressional wetland located under the Bulldog MOA, is a major nesting and roosting site for the endangered wood stork (Shaw AFB 2001). See Appendix E for a complete list of federally threatened and endangered species in the affected environment.

Wetlands. Wetlands are considered special category sensitive habitats and are subject to regulatory authority under Section 404 of the Clean Water Act and Executive Order (EO) 11990 *Protection of Wetlands*. They include jurisdictional and non-jurisdictional wetlands. Jurisdictional wetlands are those defined by the U.S. Army Corps of Engineers (USACE) and U.S. Environmental Protection Agency as those areas that meet all the criteria defined in the USACE's *Wetlands Delineation Manual* (USACE 1987) and are under the jurisdiction of the USACE. For proposed actions not involving direct ground disturbance, wetlands are typically not considered. However, because the proposal involves chaff and flare deployment, consideration of wetlands is given for the residual materials that fall to the earth and potentially into wetlands.

The numerous wetlands found under the Bulldog A/B and Gamecock B/C/D MOAs are dominated by a variety of grass, sedge, and rush species. Carolina Bays, often called pocosins, are isolated wetlands in natural shallow depressions largely fed by rain and shallow groundwater that harbor numerous varieties of vegetation. Numerous Carolina Bays exist under the eastern portion of the Bulldog and Gamecock MOAs. Many of these bays contain trees such as black gum, sweet gum, magnolia, bald cypress, and maple, and shrubs such as sumac, buttonbush, gallberry, and red bay. Also common in Carolina Bays are water lilies, sedges, and various grasses. Wetlands also provide habitat for wildlife species (University of Georgia 2001).

Environmental Consequences

Those wildlife resources that might be affected by the deployment of chaff and flares in the MOAs have been examined to determine the significance of potential impacts. The potential impacts are based on several factors:

- the importance of the resource (i.e., legal, commercial, ecological, or scientific),
- the proportion of the resource relative to its occurrence in the region,
- the sensitivity of the resource to the proposed activities, and
- the duration of the ecological consequences.

Proposed Action

Chaff fibers and flare ash are considered non-toxic in the environment and therefore would not pose a danger to vegetation, wildlife, or special-status species. Chaff fibers could accumulate on the ground, on

foliage, or in wetlands; however, studies have shown that the fibers quickly break down in humid and acidic soil conditions of the southern states (Air Force 1997). In addition, deployment of chaff and flares in the Bulldog A/B and Gamecock B/C/D/ MOAs would occur over a large area such that accumulation of fibers or ash in any one particular area would be extremely remote. Wildlife do not use chaff fibers for food or nesting material and chaff has not been proven to be toxic to animals if ingested. Flare ash would be widely dispersed and is not expected to accumulate on foliage, produce chemical effects by contact, or change soil composition (Air Force 1997). Startle effects on wildlife from flare deployment are expected to be insignificant due to the high altitude of flare deployment (approximately 4,500 to 4,800 feet AGL) and the size of the area in which chaff and flares would be deployed. There is also little danger of fires from flares due to the high altitude of flare deployment and reliability of the flare burn design (see section 3.5, Safety). Therefore, no adverse impacts to vegetation, wildlife, wetlands, or special-status species are expected from implementation of the proposed action.

Alternative A: No Action

Under the no-action alternative, training chaff and flares would not be deployed in the Bulldog A/B and Gamecock B/C/D MOAs. Airspace operations in the MOAs would continue without the use of chaff and flares, but continued use of chaff and flares would occur within the warning areas. Under this alternative, there would be no change in existing conditions underlying the training airspace; therefore, no changes to biological resources would be expected. Ongoing effects to these resources, although considered minimal, would continue.

Alternative B: Chaff and Flare Deployment in Bulldog A/B MOAs Only

Potential impacts to biological resources with implementation of Alternative B would be similar to those already described under the proposed action. Therefore, there would be no significant impacts to vegetation, wetlands, wildlife, and special-status species with implementation of Alternative B.

Alternative C: Chaff and Flare Deployment in Gamecock B/C/D MOAs Only

Potential impacts to biological resources with implementation of Alternative C would be similar to those already described under the proposed action. Therefore, there would be no significant impacts to vegetation, wetlands, wildlife, and special-status species with implementation of Alternative C.

3.4 SOILS AND WATER

For this EA, analysis focuses on those aspects that could potentially be affected by chaff fibers, flare ash, or dud flares, particularly soils, or organic material and disintegrated rock. Bedrock (solid rock underlying the loose soil) deserves no evaluation because it would not be affected by chaff and flare deployment. Water resources analysis centers on an evaluation of rivers, streams, ponds, and lakes that are found under and immediately adjacent to the Bulldog A/B and Gamecock B/C/D MOAs. This analysis emphasizes evaluation of the effects of chaff and flare residues on these types of surface waters.

Affected Environment

The Vidalia Upland District of the Coastal Plain Physiographic Province underlies most of the Bulldog A/B MOAs with small portions of Bulldog B in the Fall Line Hills District. The Vidalia Uplands range from very gently sloping to steep slopes. The soils in the uplands are generally well drained and suitable for agriculture. Depressions occur throughout the uplands. Soils in upland depressions and on floodplains are generally poorly drained, mainly wooded, and suitable for forestry (Shaw AFB 2001). Soils throughout the study area range from extremely acid ic to strongly acid ic with a pH ranging from 3.5 to 6.0. Agricultural soils are often amended with lime to reduce acidity (USDA 2003).

Water resources underlying the Bulldog A/B MOAs include portions of the Ogeechee River, Ohoopce River, and Brier Creek. Numerous Carolina Bays exist under the eastern portion of the Bulldog B MOA. Carolina Bays, often called pocosins or referred to as ponds, are isolated water bodies in natural shallow depressions largely fed by rain and shallow groundwater that harbor a variety of vegetation. Numerous bays underlie the Bulldog A/B/ MOAs, including the Big Dukes Pond in Jenkins County (Shaw AFB 2001).

The Middle Atlantic Coastal Plain (east-central) and the Atlantic Coast Flatwoods Land Resource Area (east) underlie the Gamecock B/C/D MOAs. The topography ranges from flat to gently sloping uplands. The soils are generally well drained and suitable for agriculture. Soils in the upland depressions and on floodplains are mainly wooded and suitable for forestry (Shaw AFB 2001). Soils throughout the affected environment range from strongly acid ic to moderately acid ic with a pH ranging from 4.5 to 6.0. Agricultural soils are often amended with lime to reduce acidity (USDA 2003).

Water resources underlying the Gamecock B/C/D MOAs include portions of the Santee, Pocotaligo, Black, and Great Pee Dee Rivers. Numerous swamps are tributaries of these rivers. The southwestern portion of Gamecock D overlies a portion of Lake Marion, the largest lake in South Carolina, that overflows into the Santee River. Small depressions and Carolina Bays occur mostly under the center and eastern portion of the Gamecock B/C/D MOA. These isolated water bodies drain much of the area underlying the MOAs (Shaw AFB 2001).

Environmental Consequences

Impacts to soils and water resources from the release and breakdown of residual components of chaff and flares from the proposed action and alternatives would be considered insignificant if the residual components were non-toxic to the environment. Use of chaff could deposit fibers on land or water surfaces with the potential to affect either the physical or chemical properties of the resources. Flares would also have the potential to affect soil or water properties through accumulated deposits of flare ash or introduction of a dud flare to a water body. Such unexpended dud flares have the potential to start fires

that could affect soil or water properties. The effects of dud flares and their potential to start fires have been addressed in section 3.5, Safety, where data demonstrate that duds occur rarely and their inadvertent ignition would be rarer.

Proposed Action

Implementation of the proposed action would have a negligible affect to soil and water resources. The constituents of chaff (see Appendix A) occur naturally in the environment. Aluminum, the major component of the chaff fiber coating is one of the most abundant metals in the earth's crust, air, and water. Silica, the primary component of the glass chaff fibers, is highly prevalent in soils, rocks, and sand. In extremely high levels (e.g., pounds) accumulated chaff fibers would have the potential to generate adverse effects to these resources (Air Force 1997). Based on the quantity of chaff bundles proposed for deployment in the MOAs, the distribution of chaff would be approximately 2.83 grams in the Bulldog A/B MOAs and 9.64 grams in the Gamecock B/C/D MOAs per acre per year. Additionally, the humid conditions and acidic soil properties of soils found in Georgia and South Carolina have been found to break down chaff fibers quickly reducing the opportunity for elevated levels of mineral accumulation that could be leached into soils, surface waters, or ground waters (Air Force 1997).

Since aircraft operations in the MOAs are dispersed through the horizontal limits of the airspace, no one location would receive a consistent distribution of flares. On average, an estimated 0.02 flares dispersed in the Bulldog A/B MOAs and 0.06 flares in the Gamecock B/C/D MOAs per acre per year. Flares are designed to completely burn out (within 3.5 to 5 seconds) leaving only incidental debris (i.e., end cap and felt spacer) to fall to the ground. Flare ash could affect water resources only in extremely large quantities. However, given the large size of the Bulldog and Gamecock MOAs and the low annual number of flares that would occur over any given area, the impact would be insignificant. The constituents of flares are listed in Appendix B.

A partially burned flare or a dud flare has the potential to impact soil or water properties through reaction of the water with the flare constituents. Magnesium, an essential nutrient found in nuts, seafood and cereals, is the principal material in flare pellets. Only in extremely large quantities can magnesium affect water properties; given the number, dispersal, and reliability of flares, accumulations of such levels would be impossible. A partially burned flare could ignite a fire potentially affecting soil and water properties, however, the flares will be deployed from at least 5,000 feet MSL thereby reducing, if not eliminating, this risk. Fire safety is discussed in section 3.5.

While there is a small chance that chaff fibers, flare ash, or dud flares could collect on water surfaces, the potential effect is considered minimal. Again, the probability of such residues being deposited in any one location would be minuscule due to random flight operations and dispersal of chaff and flares. Therefore, impacts to water resources would be insignificant if the proposed action were implemented.

Alternative A: No-Action

Under the no-action alternative, training chaff and flares would not be deployed in the Bulldog A/B and Gamecock B/C/D MOAs. Airspace operations in the MOAs would continue without the use of chaff and flares. Under this alternative, there would be no change in existing conditions, therefore, no changes to the soil and water resources would be expected.

Alternative B: Chaff and Flare Deployment in Bulldog A/B MOAs Only

Under this alternative, training chaff and flares would be deployed over six counties, two rivers, and numerous smaller water bodies in Georgia. As discussed under the Proposed Action, the potential for chaff fibers, flare ash, or dud flares to accumulate to quantities that could affect soil or water properties at any one point in the six counties or in any one water body is extremely remote, therefore, minimal effects to soils and water resources would be expected from implementation of Alternative B.

Alternative C: Chaff and Flare Deployment in Gamecock B/C/D MOAs Only

Under Alternative C, training chaff and flares would be deployed over six counties, four rivers, a lake, and numerous swamps, creeks, and wetlands. As previously described, the potential for chaff fibers, flare ash, or dud flares to accumulate to quantities capable of adversely affecting soil or water properties is extremely remote. Impacts to soil and water resources would be considered insignificant from implementation of Alternative C.

3.5 SAFETY

Safety topics considered for this EA include fire safety and those issues associated specifically with chaff and flare use. Safety concerns associated with chaff include interference with FAA radar tracking or satellite communications and tracking systems, damage to aircraft from chaff system malfunctions or engine ingestion of chaff, falling debris, or distraction of pilots from chaff deployment from other aircraft. Safety issues associated with flares include duds that could strike a person on the ground or be handled improperly if found on non-DoD lands and the potential of fire ignition from flares not completely burned out before reaching the ground.

The Air Force has established five categories (Class A, B, C, D, and High Accident Potential) to define mishaps as they related to safety issues:

- Class A mishaps, the most serious, result in a loss of life, permanent total disability, a total cost in excess of \$1 million, destruction of an aircraft, or damage to an aircraft beyond economical repair.
- Class B mishaps result in a total cost of \$200,000 or more, but less than \$1 million in property damage; a permanent disability; or hospitalization of five or more personnel.
- Class C mishaps result in total damage of \$10,000 or more, but less than \$200,000; and injury or occupational illness that results in 8 hours or more of lost work; or a mishap that does not meet

the requirements for a Class A or Class B mishap, but does require reporting under the guidance in Air Force Instructions.

- Class D mishaps result in total damage of \$2,000 or more, but less than \$10,000; a loss of worker productivity of more than 1 hour, but less than 8 hours; a nonfatal injury that does not result in a loss of worker productivity; or a mishap that does not meet the criteria for a Class A, B, or C mishap, but does require reporting. Class D mishaps are not applicable to aircraft-related mishaps.
- High Accident Potential (HAP) events represent minor incidents not meeting any of the criteria for Class A, B, or C.

Affected Environment

For safety analysis, the affected environment includes the Bulldog A/B and Gamecock B/C/D training airspace, lands and people underlying and immediately adjacent to these MOAs, and both Shaw AFB and McEntire ANGS personnel handling the chaff and flares.

The primary airspace safety issue related to chaff deployment is the potential to interfere with air traffic control radar. During a 10-year period (1983 to 1993) evaluated for a 1997 analysis, the entire U.S. Air Force experienced only 53 HAP events associated with chaff systems malfunctions during flight operations involving a variety of aircraft (Air Force 1997). Twenty-nine of the 53 events (approximately 55 percent) occurred in 1985 to 1986. During this timeframe, the Air Force experienced a mechanical problem with a particular type of dispensing system resulting in a high incidence of inadvertent releases. The system was repaired in 1987 and HAP incidents for chaff systems during flight operations occurred at a rate of less than three per year (Air Force 1997). During this same 10-year period, there were no chaff system-related Class A, B, or C mishaps, and only five Class D mishaps and 42 HAP occurrences during non-aircraft related, ground operations (Air Force 1997). In the *Environmental Effects of Self-Protection Chaff and Flares Final Report*, the Air Force determined that potential radar conflicts could be avoided if prior to chaff use, a frequency clearance was obtained from the Air Force Frequency Management Center and Headquarters FAA (Air Force 1997).

Prior to using chaff in any airspace, using entities (such as Shaw AFB and McEntire ANGS) must follow the requirements outlined in the *Chairman of the Joint Chiefs of Staff Manual 3212.02-Enclosure C Frequency Clearance and Notification Requirements* and submit a clearance request to the Air Force Frequency Management Office (DoD 2002) through their Major Command Frequency Management Office. After consultation with the area frequency coordinator, the request is forwarded to the FAA and the Federal Communications Commission national and regional offices for approval. The FAA's Spectrum Policy and Management Office (ASR-1) is the approving agency for DoD chaff use requests. As part of the approval process, this office considers all the information relative to the type of chaff, time, altitude, location of employment, and potential to interfere with any of the air traffic control frequency

bands. The annual request is then approved, approved with restrictions, or denied (Air Force 2001). Currently, release of chaff and flares in warning areas W-161 A/B and W-177 A/B is approved. The FAA has issued a message stating that it has no problem with military deployment of RR-188 training chaff in overland MOA airspace (FAA 2001).

The Air Force has analyzed the potential safety issues associated with flare use in terms of fire risk (i.e., hazard conditions), flare system malfunction, and possible injury to people on the ground from falling residue flare components and/or dud flares (Air Force 1997). The analysis indicated that the primary concern with flare use is the potential to start fires. Secondary would be the potential for dud flares and residual components to strike a person on the ground, especially over non-DOD land (Air Force 1997). Additional concerns are related to a malfunctioning impulse cartridge, storage conditions, or mishandling during the loading process.

According to the Air Force 1997 report, from 1983 to 1993, flares were involved in both aircraft and non-aircraft related mishaps (Air Force 1997). During this 10-year period, there were no Class A or Class B mishaps and three Class C mishaps and 101 HAP occurrences involving flares that were aircraft related. This constitutes a yearly average of 0.3 Class C and 10.1 HAP mishaps. The mishaps occurred during materials handling, maintenance, and inspection and testing/troubleshooting of flare systems. During this same period, 156 non-aircraft related mishaps were reported. There were no Class A mishaps, 2 Class B mishaps, 21 Class C mishaps, 26 Class D mishaps, and 107 HAP events. These incidents occurred primarily during maintenance activities such as movement, inspection, and system troubleshooting. None of the incidents resulted in serious injury (Air Force 1997).

Environmental Consequences

Proposed Action

RR-188 training chaff will be the only type of chaff authorized for use in Bulldog A/B and Gamecock B/C/D MOAs under the proposed action. This type of training chaff has the dipole fibers removed thereby eliminating interference with FAA radar tracking systems and has been approved for use by the FAA. Therefore, potential safety issues related to aircraft and FAA tracking systems are not anticipated.

Safety issues to people underneath or immediately adjacent to the MOAs would emanate from the probability of chaff debris striking an individual on the ground. Data on this issue are difficult to obtain; however, there have been no reports of any person being injured from falling chaff debris. Chaff debris consists of two 1-inch square plastic pieces only 1/8-inch thick. The individual end caps weigh approximately 0.042 ounces. Previous analysis indicate that if a person on the ground was hit by an ejected end cap, the impulse impact would be 0.003 pound-seconds; the impulse impact required to cause brain injury is 0.10 pound-seconds (Air Force 1997). Therefore, the safety risk to people under or

adjacent to the MOAs in which chaff is dispensed would be minimal if the proposed action were implemented.

Safety risks to aircrews and personnel from handling or discharging of chaff would be minimal. The 10-year mishap record for chaff at Air Force installations is low (Air Force 1997) and all chaff maintenance, handling, storage, and operations are performed by qualified personnel who are required to follow detailed procedures as outlined in Air Force Technical Orders and Air Force Occupational and Environmental Safety, Fire Protection, and Health directives. The historic record of chaff mishaps and the handling of this material by trained personnel support the conclusion that there would be minimal safety risks to aircrew and personnel from chaff if the proposed action were implemented.

Under the proposed action, M-206 and MJU-7 flares would be dispensed. The flares are magnesium pellets wrapped with aluminum-filament-reinforced tape, inserted into an aluminum case closed with a felt spacer and end cap. Activated by a pyrotechnic charge that forces the flare from the flare dispenser mounted within the aircraft, the activated flare burns for a period of 3.5 to 5 seconds at approximately 2,000 degrees Fahrenheit. Flares are designed to burn out completely within 325 feet after release. After activation, the end cap of the flare falls to the ground. The end cap weighs approximately 0.16 ounces, creating the potential to generate an impact momentum of 0.010 pound-seconds (Air Force 2001 and 1997). If an end cap struck a person on the ground, the momentum generated would be far below that required to cause serious injury. Therefore, safety risks related to flare debris would be negligible under the proposed action.

Flares have a greater than 99 percent reliability rate for discharging and burning as designed based on individual events. On extremely rare occasions, however, a flare may not ignite and fall to the earth as a dud flare. A dud flare could seriously injure a person if he or she is either struck by the falling dud and/or a dud flare is discovered by a person and mishandled. Previous analysis has determined the probability of a dud flare striking a person on the ground is correlated with population density (Air Force 1997). To reduce the risk of flares striking a person on the ground, flares would not be released over established communities beneath the airspace. Dud flares may be mishandled if discovered on non-DoD lands by the uninformed public. Therefore, Shaw AFB would initiate a public information campaign to inform the public about the hazards of dud flare discovery and the procedures for reporting such findings. Safety risks from dud flares, therefore, would be minimized given these informational efforts and the low probability of such occurrences if the proposed action were implemented.

In terms of fire safety, flares have the potential to ignite a ground fire if deployed below Air Force-approved altitudes that range from 400 to 1,000 feet AGL. To provide an extra margin of safety, the Air Force prohibits release of flares below 2,000 feet AFL over non-DoD owned or controlled lands. Under the proposed action, flares would not be released at less than 5,000 feet MSL or higher in any of the

MOAs, providing a significant buffer. Therefore, the potential to ignite a fire from flares would be extremely remote.

Flares also offer substantial reliability of operation – duds or failures occur rarely. The mishap rate, based on individual events, is less than 1 in 100. This means that every time a flare is deployed from the aircraft, the probability of the individual flare malfunctioning is less than 1 percent. To reduce the risk of fires, F-16 pilots from Shaw AFB and McEntire ANGS would not deploy flares under high fire conditions as defined by the National Weather Service using the National Fire Danger Rating System. In addition, the Air Force would inform local fire departments in dud flare handling procedures and would cooperate with local agencies for response to flare-related fires. Implementation of these management practices would greatly reduce the risk of fire from flares; therefore no significant impacts would be expected if the proposed action were implemented.

Alternative A: No-Action

Under the no-action alternative, chaff and flares would not be dispersed in the Bulldog A/B and Gamecock B/C/D MOAs. Airspace operations in the MOAs would continue without the use of chaff and flares. Under this alternative, there would be no change to existing safety conditions.

Alternative B: Chaff and Flare Deployment in Bulldog A/B MOAs Only

Potential impacts to safety with implementation of Alternative B would be similar to those already described under the proposed action. Therefore, there would be no significant impacts to safety both in the airspace and on the ground to the public or personnel at Shaw AFB and McEntire ANGS under Alternative B.

Alternative C: Chaff and Flare Deployment in Gamecock B/C/D MOAs Only

Potential impacts to safety with implementation of Alternative C would be similar to those already described under the proposed action. Therefore, there would be no significant impacts to safety both in the airspace and on the ground to the public or personnel at Shaw AFB and McEntire ANGS under Alternative C.

3.6 MATERIALS MANAGEMENT

Materials management considers the transportation, storage, and disposal of chaff and flares at Shaw AFB and McEntire ANGS. In addition, this section evaluates the expansion of chaff and flare use in the Bulldog A/B and Gamecock B/C/D MOAs and the potential effect of chaff and flares constituents on humans and the natural environment. Under this analysis, materials management focuses on the increased inventory levels of chaff and flare materials and the ability of both Shaw AFB and McEntire ANGS to store, transport, and dispose of these materials and the introduction of these materials into the MOA airspace. The safety aspects of both chaff and flares are addressed under Safety, section 3.5.

Affected Environment

The affected environment under materials management includes Shaw AFB and McEntire ANGS where storage, transportation, and disposal of chaff and flare materials occurs and those land areas immediately under and adjacent to the Bulldog A/B and Gamecock B/C/D MOAs.

Currently, each installation actively manages their inventory of chaff and flares using existing approved procedures. The Air Force classifies chaff and flare cartridges as munitions due to the pyrotechnic charge that ejects the chaff fibers and flare material from the aircraft. Shipped to the installations from a supply depot and stored in munitions storage facilities designed for such materials, the chaff and flares are only then transported to the flight line and loaded on the aircraft prior to training missions. Following the missions, trained ground crews remove the unused chaff and flares from the aircraft and return them to the storage facility for future use. Chaff and flares with expired shelf lives or defects are returned to the supply depot responsible for their disposal. Final disposal of unusable chaff and flares does not occur at Shaw AFB or McEntire ANGS.

Both Shaw AFB and McEntire ANGS are only authorized to conduct training using both chaff and flares in overwater warning areas W-161 A/B and W-177 A/B. Flare-only training is authorized in the restricted airspace over Poinsett ECR (located south of Shaw AFB) but rarely occurs (Byers 2003). Currently, chaff and flares are not authorized over any non-DoD lands.

Environmental Consequences

Proposed Action

Under the proposed action, F-16 aircrews from Shaw AFB and McEntire ANGS would deploy chaff and flares in the Bulldog A/B MOAs in Georgia and Gamecock B/C/D MOAs in South Carolina. The expansion of operations to overland MOAs would triple the inventory at Shaw AFB and quadruple the inventory at McEntire ANGS. The respective installations currently have the ability to store, transport, and dispose of inventories of chaff and flares and have the capacity to store, transport, and dispose of these increased levels of inventory under the proposed action; therefore no adverse impacts to materials management, storage, or disposal are anticipated.

In order to evaluate the potential effects of chaff and flare constituents on the lands underlying the MOAs, chaff and flare materials (i.e., chaff fibers, end caps, and felt spacers, as well as dud flares) distribution and concentration would be assumed to be fairly random but consistent, with the exception of 1 to 2 miles inside the MOA boundaries. The level of chaff and flare materials will be less near the edges of the MOAs because pilots tend to avoid flying to the extreme limits of the airspace boundaries (this has been determined through noise modeling and radar tracks that operations near the edges of MOAs decrease at a

linear rate [Lucas and Calamia 1994]). Table 3-2 provides the proposed level of deployment of chaff bundles and flares in each MOA.

<i>MOA</i>	<i>Chaff Bundles RR-188</i>	<i>Flares M-206 / MJU-7</i>
Bulldog A/B	57,600	38,400
Gamecock B	4,800	3,200
Gamecock C/D	115,200	76,800

Based on the assumption that the expected number of chaff and flares in the MOA airspace would be distributed fairly consistently, expected concentrations of chaff fibers or flare ash in the Bulldog MOAs would be approximately 0.10 ounces (2.83 grams) per acre per year; an estimated 0.02 flares would be distributed per acre per year. In the Gamecock MOAs, chaff concentrations would be nearly 0.34 ounces (9.64 grams) per acre per year, with 0.06 flares distributed per acre per year. These amounts would be reduced by half within 1 to 2 miles of the airspace boundaries (Air Force 1997).

Chaff consists of small aluminum-coated silica fibers covered with a slip coating of stearic acid (fat). The major components of chaff are found in the environment (see Appendix A for specific attributes of chaff fibers). Silica is inert in the environment and aluminum is the third most abundant element in the earth's crust. The silica is primarily composed of silicon dioxide and also contains trace elements of aluminum, calcium oxide and magnesium oxide, boron oxide, sodium and potassium oxide, and iron oxide. The aluminum coating comprises trace quantities of silicon, iron, copper, manganese, magnesium, zinc, vanadium, and titanium. Some of these individual components, in sufficient quantities, have toxic risks; however, in chaff, these elements are in minute quantities and are fused together in a stable state and it is unlikely that they would break down to their independent forms or react chemically with other substances. The chemicals individually make up such a minuscule portion of the fibers that it is unlikely they would contribute to environmental toxicity (Air Force 1997). These factors, combined with the wide dispersion of the fibers and the low potential for accumulation of these materials in any one area support the conclusion that there would be negligible toxic effects on people and the natural environment.

Constituents of flares and flare ash residues do not represent toxic or dangerous materials. Only in enormous quantities would such residues have potential toxic effects if consumed or ingested. Such an occurrence would be highly improbable, since dud flares are rare and all flare use would be dispersed over thousands of square miles. Dud flares and their risks are discussed in Safety, section 3.5.

Alternative A: No-Action

Under the no-action alternative, no impacts to materials management would occur. Shaw AFB and McEntire ANGS would continue to deploy chaff and flares in the overwater warning areas and rarely in the restricted airspace over Poinsett ECR with no increase in materials storage, transport, or disposal.

Alternative B: Chaff and Flare Deployment in Bulldog A/B MOAs Only

Potential impacts to materials management with implementation of Alternative B would be similar to those already described under the proposed action. Therefore, there would be no significant impacts to materials management at the Shaw AFB and McEntire ANGS or to people or the natural environment underlying the MOA airspace under Alternative B.

Alternative C: Chaff and Flare Deployment in Gamecock B/C/D MOAs Only

Potential impacts to materials management with implementation of Alternative C would be similar to those already described under the proposed action. Therefore, there would be no significant impacts to materials management at the Shaw AFB and McEntire ANGS or to people or the natural environment underlying the MOA airspace under Alternative C.

3.7 ENVIRONMENTAL JUSTICE

Executive Order 12898, *Federal Actions to Address Environmental Justice in Minority Populations and Low-Income Populations*, directs federal agencies to evaluate the potential for federal actions to cause disproportionate health and environmental impacts on minority and low-income populations. Similarly, Executive Order 13045 (*Protection of Children from Environmental Health Risks and Safety Risks*), addresses protection of children from disproportionate environmental health and safety risks from federal actions. Minority, low-income, and youth populations are defined as:

- *Minority Populations:* Persons of Hispanic origin of any race, Blacks, American Indians, Alaska Native, Asians, or Pacific Islanders.
- *Low-Income Populations:* Persons living below the poverty level, based on a total income of 17,761 for a family of four persons as reported in the 2000 census (Census 2000).
- *Youth Population.* Children under the age of 18 years.

In this EA, the anticipated environmental effects of chaff fibers, dud flares, and flare ash accumulations as well as aircraft noise levels are evaluated for their potential effect to environmental justice. Analysis determined whether there would be a disproportionately high and/or adverse effect to minority or low-income populations. Information from the 2000 Census of Population and Housing was used to identify these populations. These data do not report minority population, but provides data by race and ethnic origin. These data were used to estimate minority populations potentially affect by implementation of the proposed action and alternatives.

Affected Environment

The populations underlying and immediately adjacent to the Bulldog A/B and Gamecock B/C/D MOAs encompass the affected environment. To properly assess the potential for disproportionate health or environmental impacts to low-income or minority populations, disadvantaged groups within the affected environment are specifically considered. Under the Bulldog A/B MOAs, 25.5 percent of the people and 33.9 percent of the children under 18 years of age live below the poverty line (Census 2000). Overall, in the state of Georgia 13.0 percent of the people and 16.7 percent of the children live below the poverty line (Census 2000). The higher percent of people and children living below the poverty line under the Bulldog A/B MOAs most likely reflects the rural nature of this region of the state. The closest city is Augusta, 25 miles from the northeast border of the MOAs.

Youth population accounts for 28.8 percent of the affected environment population compared to 26.5 percent at the statewide Georgia level. The senior population, those individuals age 65 and older, account for 13.3 percent under the Bulldog A/B MOAs and 9.6 percent statewide (Census 2000).

Minority persons represent just under half the population (47.3 percent) under the Bulldog A/B MOAs. By comparison, minority persons represent 35.2 percent of the state's population. Black or African American persons account for 45.4 percent of the population for the counties underlying the MOAs, or 96 percent of the total minority population in the affected environment (Census 2000).

For the affected environment underlying the Gamecock B/C/D MOAs, 27.9 percent of the people and 30 percent of the children live below the poverty line. South Carolina state levels are 14.1 percent of persons and 18.5 percent of children living below the poverty line (Census 2000). As with the Bulldog MOAs, these numbers likely reflect the rural nature of the region underlying the MOAs. The closest city Orangeburg, is 50 miles from the western edge of Gamecock D MOA.

Youth population accounts for 26.8 percent of the population underlying the MOAs compared to 25.2 percent at the South Carolina state level. The senior population, those individuals age 65 and older, accounts for 24.6 percent of the population under the Gamecock B/C/D MOAs and 12.1 percent of the state population (Census 2000).

Under the Gamecock B/C/D MOAs, persons defined as minorities represent 49.4 percent of the population. By comparison, minority persons represent 33.1 percent of the state's population. Black or African American persons account for 47.1 percent of the minority population in the counties underlying the MOAs, or 95 percent of the total minority population in the affected environment (Census 2000).

Environmental Consequences

Noise levels under the Bulldog A/B and Gamecock B/C/D MOAs will not change due to implementation of the proposed action or alternatives. No new aircraft will be introduced, current flight levels would remain in effect, and operations would take place in the same altitude regimes. A review of the area established that no populations of any kind, including minority or low-income populations, are currently or would be subjected to noise levels of 65 decibels, average day-night sound level (DNL) or higher under the proposed action or alternatives. Use of this 65 DNL guideline for the evaluation of environmental justice issues in relation to sporadic military training flights is consistent with the intent of EO 12898. No disproportionate adverse effects on minority persons, low-income populations, or children would be anticipated under implementation of the proposed action and alternatives. The following focuses on the potential effect of chaff fiber, dud flare, and flare ash accumulation under the proposed action and alternatives.

Proposed Action

No significant impacts to low-income or minority populations would occur through implementation of the proposed action. Chaff and flare dispersal will occur throughout the expanse of the Bulldog A/B and Gamecock B/C/D MOAs resulting in no one community, low-income, minority, or youth population being disproportionately affected. Therefore, no significant impacts are anticipated to environmental justice if the proposed action were implemented. See section 3.5, Safety and 3.6 Materials Management for discussion of chaff fibers, dud flares, and flare ash.

Alternative A: No-Action

Under the no-action alternative, no impacts to environmental justice would occur. Shaw AFB and McEntire ANGS would continue to operate in the MOA airspace in the same manner.

Alternative B: Chaff and Flare Deployment in Bulldog A/B MOAs Only

Potential impacts to environmental justice with implementation of Alternative B would be similar to those already described under the proposed action. Therefore, there would be no significant impacts to low-income, minority, and youth populations underlying the MOA airspace under Alternative B.

Alternative C: Chaff and Flare Deployment in Gamecock B/C/D MOAs Only

Potential impacts to environmental justice with implementation of Alternative C would be similar to those already described under the proposed action. Therefore, there would be no significant impacts to low-income, minority, and youth populations underlying the MOA airspace under Alternative C.

CHAPTER 4

CUMULATIVE EFFECTS AND IRREVERSIBLE AND IRRETRIEVABLE COMMITMENT OF RESOURCES

CHAPTER 4

CUMULATIVE EFFECTS AND IRREVERSIBLE AND IRRETRIEVABLE COMMITMENT OF RESOURCES

4.1 CUMULATIVE EFFECTS

A cumulative effects analysis should consider the potential environmental impacts resulting from the incremental impacts of the action when added to other past, present, and reasonably foreseeable future actions regardless of what agency or person undertakes such other actions (40 CFR 1508.7). Assessing cumulative effects involves defining the scope of the other actions and their interrelationship with the proposed action and alternatives, if they overlap in space and time. Cumulative effects are most likely to arise when a proposed action is related to other actions that occur in the same location or at a similar time. Actions geographically overlapping or close to the proposed action and alternatives would likely have more potential for a relationship than those farther away. Similarly, actions coinciding in time with the proposed action and alternatives would have a higher potential for cumulative effects.

To identify cumulative effects, the analysis needs to address three questions:

1. Could affected resource areas of the proposed action interact with the affected resource areas of past, present, or reasonably foreseeable actions?
2. If one or more of the affected resource areas of the proposed action and another action could interact, would the proposed action affect or be affected by impacts of the other action?
3. If such a relationship exists, are there any potentially significant impacts not identified when the proposed action is considered alone?

4.2 SCOPE OF CUMULATIVE EFFECTS ANALYSIS

The scope of the cumulative effects analysis involves both the geographic extent of the effects and the time in which the effects could occur. The cumulative effects analysis includes the affects on airspace and the lands underlying the MOAs for the proposed action and alternatives. Actions not occurring within or near the affected environment are not considered in the analysis. Public documents prepared by federal, state, and local government agencies were the primary sources of information for identifying reasonable foreseeable actions.

Past and Present Actions

Past and present actions, that when combined with the proposed action, would result in cumulative effects have not been identified. No known actions by other branches of the military or the FAA with the potential to result in cumulative effects within the airspace have been identified. No actions on lands underlying the MOAs were identified with the potential to result in cumulative effects.

Future Proposed Actions

A proposal by the Air Force to place a mobile laser evaluation system (LES-M) at Poinsett Electronic Combat Range and equip F-16 aircraft from Shaw AFB with targeting and navigation pods has been identified as a future action. The LES-M system would provide Shaw AFB aircrews with the ability to identify a target in the Bulldog A/B or Gamecock B/C/D MOAs with Sniper XR targeting and navigation pod and then simulate ordnance delivery on the target (i.e., nothing released from the aircraft). The laser training would occur during normal training sorties and no new operations or airspace would be developed. The LES-M proposal would not be expected to generate any cumulative effects because the only change would be upgrading to the Sniper XR pods on the F-16 aircraft currently flying from Shaw AFB in the airspace. Numbers, altitudes, and times of aircraft operations would not change under either action. No other future actions were identified that could cumulatively affect either the airspace of lands underlying the MOAs.

4.3 IRREVERSIBLE AND IRRETRIEVABLE COMMITMENT OF RESOURCES

NEPA requires that environmental analysis include identification of any irreversible and irretrievable commitment of resources which would be involved in the proposed action should it be implemented. Irreversible and irretrievable resource commitments are related to the use of nonrenewable resources and the effects this use could have on future generations. Irreversible effects primarily result from the use or destruction of a specific resource (e.g., energy and minerals) that cannot be replaced within a reasonable time frame. Irretrievable resource commitments involve the loss in value of an affected resource that cannot be restored as a result of the action (e.g., extinction of a threatened or endangered species or the disturbance of a cultural resource).

For this proposal, all resource commitments are neither irreversible nor irretrievable. Those limited resources that may involve a possible irreversible or irretrievable commitment are discussed below.

Aircraft used by Shaw AFB and McEntire ANGS would consume fuel, oil, and lubricants. The amount of materials used would not exceed that currently consumed during the routine training exercises. As such, the consumption of these resources would not increase under the proposed action or alternatives.

Use of chaff and flares would have only minimal effects to natural and biological resources including the habitats of special status species.

CHAPTER 5

REFERENCES CITED

CHAPTER 5

REFERENCES CITED

- Department of Defense (DoD). 2002. Chairman of the Joint Chiefs of Staff Manual: Performing Electronic Attack in the United States and Canada for Tests, Training, and Exercises. Enclosure C, Frequency Clearance and Notification Requirements. March.
- Federal Aviation Administration (FAA). 2001. Deployment of RR-188 Training Chaff. Message #182223Z. April.
- Georgia Department of Natural Resources (GADNR). 2003. Federal Special Status Species List by County. <http://georgiawildlife.dnr.state.ga.us>. June.
- Georgia State Parks (GSP). 2003. Georgia State Parks and Historic Sites. <http://www.gastateparks.org>.
- Georgia's Water Resources (GWR). 2003. Georgia River Network. <http://www.garivers.org>.
- General Accounting Office (GAO). 1998. Environmental Protection: DoD Management Issues Related to Chaff. September.
- Lucas, M.J. and P.T. Calamia. 1994. Military Operating area and Range Noise Model MR_NMAP User's Manual. Wyle Research Report WR 94-12. Prepared by Wyle Laboratories for Systems Research Laboratories, Inc.
- Shaw AFB. 2001. Utilization of Shaw Air Force Base Managed Airspace. Final Environmental Assessment August.
- South Carolina Department of Natural Resources (SCDNR). 2003. Federal Special Status Species List by County. <http://www.dnr.state.sc.us>. June.
- South Carolina Lakes (SCL). 2003. The Lakes of South Carolina. <http://www.sclakes.com>.
- United States Air Force (Air Force). 2002. Environmental Assessment for Force Structure Change at Shaw Air Force Base, South Carolina. November.
- _____. 2001. Defensive Training Initiative. Final Environmental Assessment. September.
- _____. 1997. Environmental Effects of Self-Protection Chaff and Flares. Final Report. August.

United States Army Corps of Engineers (USACE). 1987. Corps of Engineers Wetlands Delineation Manual. Technical Report Y-87-1. Waterways Experiment Station, Vicksburg, MS. January.

United States Department of Agriculture (USDA). Natural Resources Conservation Service (NRCS). Georgia Soil Survey. 2003. <http://www.ga.nrcs.usda.gov/technical/soils/soilsinfo.html>.

_____. Natural Resources Conservation Service (NRCS). South Carolina Soil Survey. 2003. <http://ortho.ftw.nrcs.usda.gov/osd/osd.html>.

United States Environmental Protection Agency (USEPA). 2003. EPA AirData – Nonattainment Areas Map. <Http://www.epa.gov/air/data/nonat.html>.

United States Geological Survey (USGS). 2001. Land Use and Land Cover Data. BASINS Version 3.0. June.

University of Georgia. 2001. Carolina Bays Fact Sheet. <http://www.uga.edu/srel/bays.htm>.

U.S. Bureau of the Census (Census). 2001. Estimates of the Population by Age, Sex, and Race/Hispanic Origin. Data files prepared by the U.S. Bureau of the Census. Washington, D.C.

CHAPTER 6

PERSONS AND AGENCIES CONTACTED

CHAPTER 6

PERSONS AND AGENCIES CONTACTED

Aanrud, Maj. Jay. Operations. 20 OSS/OSO, Shaw AFB. July 2003.

Apple, Kent. Airspace Manager. ACC/DORA, Langley AFB. July 2003.

Banks, Roger. Ecological Field Office. U.S. Fish and Wildlife Service, South Carolina. July 2003.

Barrett, Lonice. Historic Preservation Division, Georgia Department of Natural Resources. July 2003.

Brooks, Robert. Coastal Georgia Field Office. U.S. Fish and Wildlife Service. July 2003.

Byers, Art. Airspace Manager, 20 OSS/OSOA, Shaw AFB. July 2003.

Connelly, Pete. Range Manager. 20 OSS/OSTR, Shaw AFB. July 2003.

Cook, Michele. ACC Project Manager. ACC/CEVP, Langley AFB. 2003.

Edmonds, Mary W. Deputy. State Historic Preservation Office, South Carolina. July 2003.

Gause, David. EIAP Project Manager. 20 CES/CEV, Shaw AFB. July 2003.

Hamilton, Sam. South Carolina and Georgia Regional Office. U.S. Fish and Wildlife Service.
July 2003.

Hunter, Earl. Commissioner. South Carolina Department of Health and Environmental Control.
July 2003.

Madewell, Terry. Natural/Cultural Resources Manager. 20 CES/CEV, Shaw AFB. July 2003.

Roberts, Richard. Airspace Manager. ACC/DORA, Langley AFB. July 2003.

Sandifer, Dr. Paul A. Director. South Carolina Department of Natural Resources. July 2003.

Tucker, Sandy. North Georgia Field Office. U.S. Fish and Wildlife Service. July 2003.

Van Allen, Lt. Jean M. Public Affairs Officer, 20 FW/PA, Shaw AFB. June 2003.

CHAPTER 7

PREPARERS AND CONTRIBUTORS

CHAPTER 7

LIST OF PREPARERS AND CONTRIBUTORS

Christina Cummings, Production Coordinator
A.A.S., Administrative Office Technology, Boise State University, ID 1999
Years of Experience: 4

Chareé D. Hoffman, Environmental Analyst
B.S., Biology, Christopher Newport University, VA, 1999
Years of Experience: 5

Eddie Mertz, Graphics
A.A. General Education, Cerro Coso College, CA, 1994
Years of Experience: 13

Kevin J. Peter, Program Manager
B.A., Anthropology, Pomona College, CA, 1975
M.A., Anthropology, Washington State University, 1986
Years of Experience: 24

Kathy L. Rose, Project Manager
B.A., Political Science/German, University of Massachusetts/Amherst, 1980
M.A., International Relations, George Washington University, DC 1983
M.S., Forest Resource Management, University of Idaho, 1996
Years of Experience: 7

Rick Spaulding, Biological Resources
B.A., Biology, University of California/Santa Cruz, 1982
M.S., Wildlife and Fisheries Science, University of Arizona, 1996
Years of Experience: 19

APPENDIX A

Characteristics of Chaff

APPENDIX A

CHARACTERISTICS OF CHAFF

The proposed action would employ RR-188 training chaff. When released from an aircraft, chaff initially forms a sphere, then disperses in the air. The chaff effectively reflects radar signals in various bands (depending on the length of the chaff fibers) and forms a very large image or electronic “cloud” of reflected signals on a radar screen. The aircraft is obscured from radar detection by the cloud, which allows the aircraft to safely maneuver or to leave an area. Since chaff can obstruct radar, its use is coordinated with the Federal Aviation Administration (FAA). RR-188 training chaff has D and E band dipoles removed to avoid interference with FAA radar.

Chaff Composition

The RR-188 chaff used during training consists of extremely small strands (or dipoles) of an aluminum-coated crystalline silica core. The chaff components (silica, aluminum, and stearic acid) are generally prevalent in the environment. Silica (silicon dioxide) belongs to the most common mineral group, silicate minerals. Silica is inert in the environment and does not present an environmental concern with respect to soil chemistry. Aluminum is the third most abundant element in the earth’s crust, forming some of the most common minerals, such as feldspars, micas, and clays. Natural soil concentrations of aluminum ranging from 10,000 to 300,000 parts per million have been documented (Lindsay 1979). These levels vary depending on numerous environmental factors, including climate, parent rock materials from which the soils were formed, vegetation, and soil moisture alkalinity/acidity. The solubility of aluminum is greater in acidic and highly alkaline soils than in neutral pH conditions. Aluminum eventually oxidizes to Al_2O_3 (aluminum oxide) over time, depending on its size and form and the environmental conditions. Stearic acid is an animal fat that degrades when exposed to light and air.

Chaff fibers have an anti-clumping agent (Neofat – 90 percent stearic acid and 10 percent palmitic acid) to assist with rapid dispersal of the fibers during deployment (Air Force 1997). Chaff is made as small and light as possible so that it will remain in the air long enough to confuse enemy radar. The chaff fibers are approximately the thickness of a human hair (i.e., generally 1 millimeter in diameter), and range in length from 0.3 to over 1 inch. The weight of chaff material in the RR-188 cartridge is 95 grams (Air Force 1997).

A single bundle of chaff consists of the filaments in an 8-inch long rectangular tube or cartridge, a plastic piston, a cushioned spacer and a 1-inch by 1-inch plastic end cap that falls to the ground when chaff is dispensed. The spacer is a spongy material (felt) designed to absorb the force of release. Figure A-1 illustrates the components of a chaff cartridge. Table A-1 lists the components of the silica core and the aluminum coating. Table A-2 presents the characteristics of RR-188 chaff.

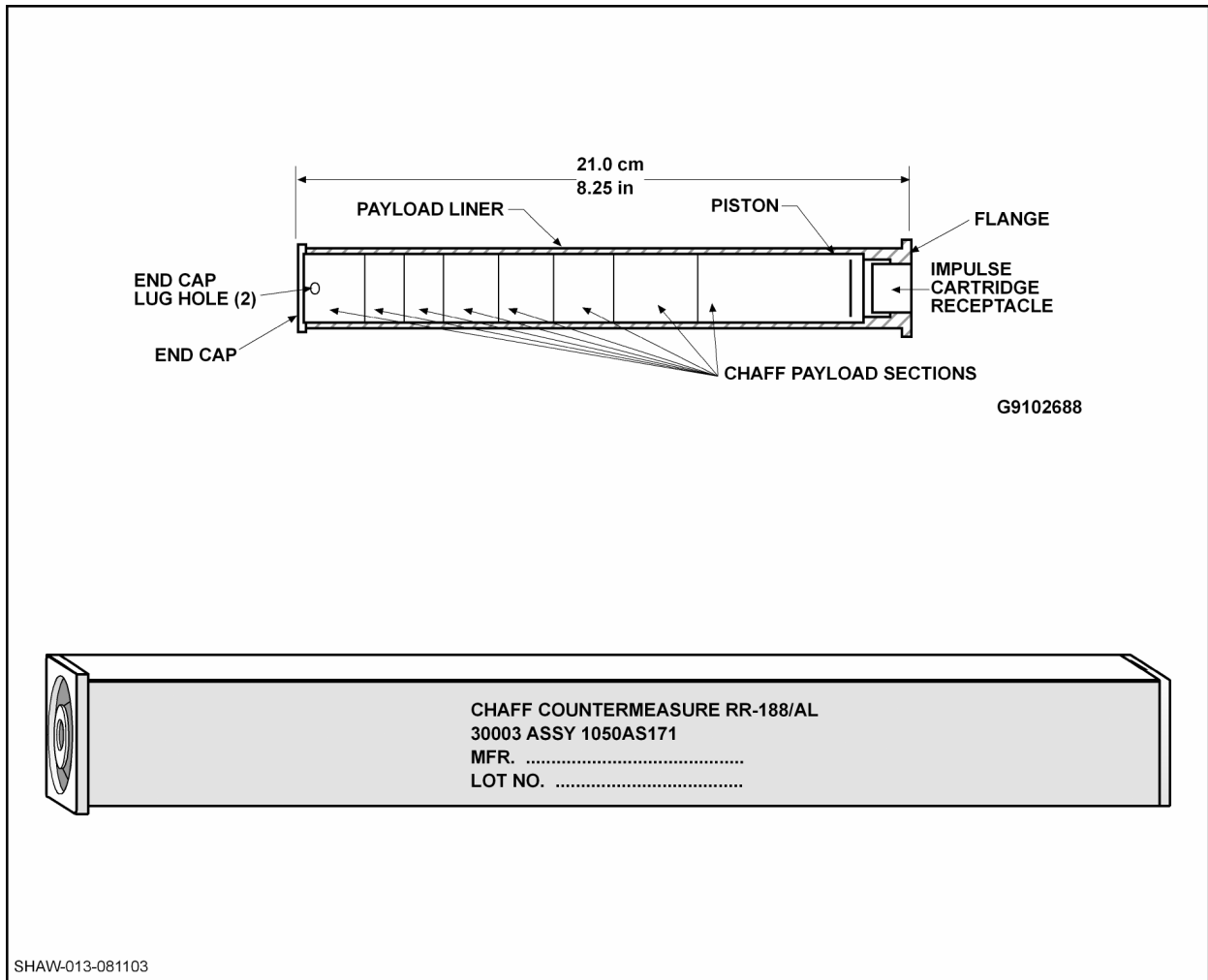

Figure A-1 RR-188/AL Chaff Cartridge (Air Force 1999)

Chaff Ejection

Chaff is ejected from aircraft pyrotechnically using a BBU-35/B impulse cartridge. Pyrotechnic ejection uses hot gases generated by an explosive impulse charge. The gases push the small piston down the chaff-filled tube. A small plastic end cap is ejected, followed by the chaff fibers. The plastic tube remains within the aircraft. Debris from the ejection consists of two small, square pieces of plastic 1/8-inch thick (i.e., the piston and the end cap) and the felt spacer. Table A-3 lists the characteristics of BBU-35/B impulse cartridges used to pyrotechnically eject chaff.

Table A-1 Components of RR-188 Chaff		
<i>Element</i>	<i>Chemical Symbol</i>	<i>Percent (by weight)</i>
Silica Core		
Silicon dioxide	SiO ₂	52-56
Alumina	Al ₂ O ₃	12-16
Calcium Oxide and Magnesium Oxide	CaO and MgO	16-25
Boron Oxide	B ₂ O ₃	8-13
Sodium Oxide and Potassium Oxide	Na ₂ O and K ₂ O	1-4
Iron Oxide	Fe ₂ O ₃	1 or less
Aluminum Coating (Typically Alloy 1145)		
Aluminum	Al	99.45 minimum
Silicon and Iron	Si and Fe	0.55 maximum
Copper	Cu	0.05 maximum
Manganese	Mn	0.05 maximum
Magnesium	Mg	0.05 maximum
Zinc	Zn	0.05 maximum
Vanadium	V	0.05 maximum
Titanium	Ti	0.03 maximum
Others		0.03 maximum

Source: Air Force 1997

Table A-2 Characteristics of RR-188 Chaff	
<i>Attribute</i>	<i>RR-188</i>
Aircraft	A-10, F-15, F-16
Composition	Aluminum coated glass
Ejection Mode	Pyrotechnic
Configuration	Rectangular tube cartridge
Size	8 x 1 x 1 inches (8 cubic inches)
Number of Dipoles	5.46 million
Dipole Size (cross-section)	1 mil (diameter)
Impulse Cartridge	BBU-35/B
Other Comments	Cartridge stays in aircraft; less interference with FAA radar (no D and E bands)

Source: Air Force 1997

Table A-3 BBU-35/B Impulse Charges Used to Eject Chaff	
<i>Component</i>	<i>BBU-35/B</i>
Overall Size	0.625 inches x 0.530 inches
Overall Volume	0.163 inches ³
Total Explosive Volume	0.034 inches ³
Bridgewire	Trophet A 0.0025 inches x 0.15 inches
Initiation Charge	0.008 cubic inches 130 mg 7,650 psi boron 20% potassium perchlorate 80%*
Booster Charge	0.008 cubic inches 105 mg 7030 psi boron 18% potassium nitrate 82%
Main Charge	0.017 cubic inches 250 mg Loose fill RDX **pellets 38.2% Potassium perchlorate 30.5% Boron 3.9% Potassium nitrate 15.3% Super floss 4.6% Viton A 7.6%
<i>Source: Air Force 1997</i>	

Upon release from an aircraft, chaff forms a cloud approximately 30 meters in diameter in less than one second under normal conditions. Quality standards for chaff cartridges require that they demonstrate ejection of 98 percent of the chaff in undamaged condition, with a reliability of 95 percent at a 95 percent confidence level. They must also be able to withstand a variety of environmental conditions that might be encountered during storage, shipment, and operation.

Table A-4 lists performance requirements for chaff.

<i>Condition</i>	<i>Performance Requirement</i>	
High Temperature	Up to +165 degrees Fahrenheit (°F)	
Low Temperature	Down to -65°F	
Temperature Shock	Shock from -70°F to + 165°F	
Temperature Altitude	Combined temperatures altitude conditions up to 70,000 feet	
Humidity	Up to 95 percent relative humidity	
Sand and Dust	Sand and dust encountered in desert regions subject to high sand dust conditions and blowing sand and dust particles	
Accelerations/Axis	<u>G-Level</u>	<u>Time (minute)</u>
Transverse-Left (X)	9.0	1
Transverse-Fight (-X)	3.0	1
Transverse (Z)	4.5	1
Transverse (-Z)	13.5	1
Lateral-Aft (-Y)	6.0	1
Lateral-Forward (Y)	6.0	1
Shock (Transmit)	Shock encountered during aircraft flight	
Vibration	Vibration encountered during aircraft flight	
Free Fall Drop	Shock Encountered during unpackaged item drop	
Vibration (Repetitive)	Vibration encountered during rough handling of packaged item	
Three Foot Drop	Shock encountered during rough handling of packaged item	
Note: Cartridge must be capable of total ejection of chaff from the cartridge line under these conditions		
Source: Air Force 1997		

Policies and Regulations on Chaff Use

Current Air Force policy on use of chaff was established by the Airspace Subgroup of Headquarter (HQ) Air Force Flight Standards Agency (AFFSA) in 1993 (Memorandum from John R. Williams, 28 June 1993). It requires units to obtain frequency clearance from the Air Force Frequency Management Center and the FAA prior to using chaff to ensure that training with chaff is conducted on a non-interference basis. This ensures electromagnetic compatibility between the FAA, the Federal Communications Commission (FCC), and Department of Defense (DoD) agencies. The Air Force does not place any restrictions on the use of chaff provided those conditions are met (Air Force 1997).

AFI 13-201 U.S. Air Force Airspace Management, July 1994. This guidance establishes practices to decrease disturbance from flight operations that might cause adverse public reaction. It emphasizes the Air Force’s responsibility to ensure that the public is protected to the maximum extent practicable from hazards and effects associated with flight operations.

AFI 11-214 Aircrew and Weapons Director and Terminal Attack Controller Procedures for Air Operations, July 1994. This instruction delineates procedures for chaff and flare use. It prohibits use unless in an approved area.

AFI 13-212, Range Planning Operations and CJCSM 3212.02, Performing Electronic Attack in the United States and Canada for Tests, Training, and Exercises provide similar procedures for conducting training chaff and self-protection flare use in approved areas.

References

Air Force. 1997. *Environmental Effects of Self-Protection Chaff and Flares*. Prepared for Headquarters Air Combat Command, Langley Air Force Base, Virginia.

_____. 1999. *Description of the Proposed Action and Alternatives (DOPAA) for the Expansion of the Use of Self-Protection Chaff and Flares at the Utah Test and Training Range, Hill Air Force Base, Utah*. Prepared for Headquarters Air Force Reserve Command Environmental Division, Robins AFB, Georgia.

APPENDIX B

Characteristics of Flares

APPENDIX B

CHARACTERISTICS OF FLARES

The proposed action would employ both M-206 and MJU-7 self-protection flares. Self-protection flares are magnesium pellets that, when ignited, burn for a brief period of time (i.e., 3.5 to 5 seconds) at 2,000 degrees Fahrenheit (F). The burn temperature is hotter than the exhaust of an aircraft and, therefore attracts and decoys heat-seeking weapons targeted on the aircraft. This appendix describes flare composition, ejection, and associated regulations.

Flare Composition

Self-protection flares are primarily mixtures of magnesium and Teflon (polytetrafluorethylene) molded into rectangular shapes (Air Force 1997). Longitudinal grooves provide space for materials that aid in ignition such as:

- First fire materials: potassium perchlorate, boron powder, magnesium powder, barium chromate, Viton A, or Fluorel binder.
- Immediate fire materials: magnesium powder, Teflon, Viton A, or Fluorel
- Dip coat: Magnesium powder, Teflon, Viton A or Fluorel

Typically, flares are wrapped with an aluminum-filament-reinforced tape and inserted into an aluminum (0.03 inches thick) case that is closed with a felt spacer and a small plastic end cap (Air Force 1997). The top of the case has a pyrotechnic impulse cartridge that is activated electrically to produce hot gases that push a piston, the flare material, and the end cap out of the aircraft into the airstream. The M-206 flare is 8 cubic inches and the MJU-7 is 16 cubic inches in size. Table B-1 provides a description of both self-protection flare components. Typical flare composition and debris are summarized in Table B-2. Figure B-1 is an illustration of an MJU-7 flare; M-206 flares are similar in composition.

<i>Attribute</i>	<i>M-206</i>	<i>MJU-7</i>
Aircraft	A-10, AC-130, C-17, F-16	F-4, F-15, F-16, C-130
Mode	Parasitic	Semi-Parasitic
Configuration	Rectangle	Rectangle
Size	1 x 1 x 8 inches (8 cubic inches)	1 x 2 x 8 inches (16 cubic inches)
Impulse Cartridge	M-796	M-796; BBU 36/B
Safety and Initiation Device	None	Slider Assembly
Weight (nominal)	6.8 ounces	13 ounces
Comments	Simulator version (T-1) uses potassium chlorate, powdered sugar, and yellow dye smoke charge	Simulator version (T-1) uses potassium chlorate, powdered sugar, and yellow dye smoke charge

Source: Air Force 1997

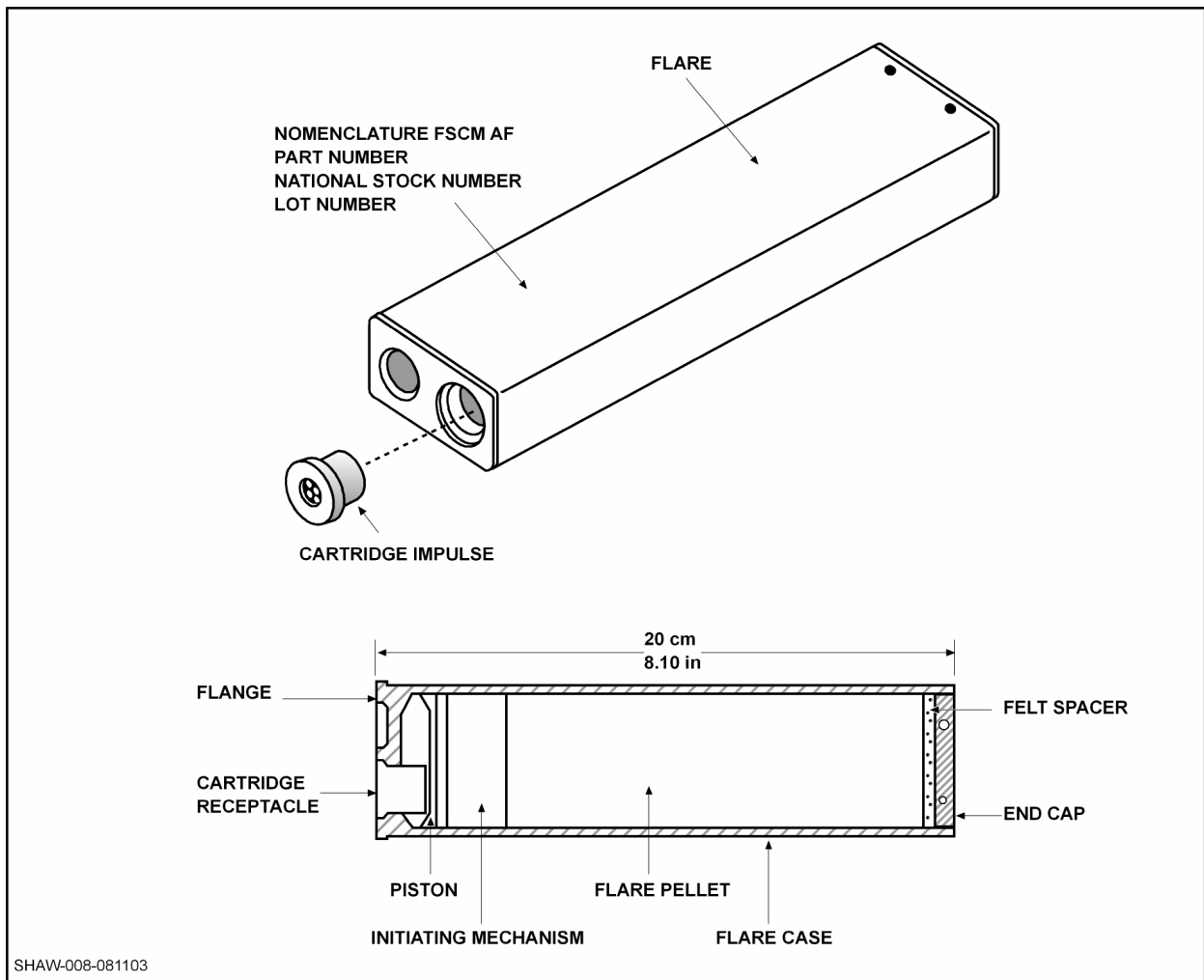

Figure B-1 MJU-7/Self Protection Flare Cartridge (Air Force 1999)

Table B-2 Typical Composition and Debris of Self-Protection Flares	
<i>Part</i>	<i>Components</i>
Combustible	
Flare Pellet	Polytetrafluorethylene (Teflon) ($-\text{C}_2\text{F}_4\text{]}_n - n=20,000$ units Magnesium (Mg) Fluoroelastomer (Viton, Fluorel, Hytemp)
First Fire Mixture	Boron (B) Magnesium (Mg) Potassium perchlorate (KClO_4) Barium chromate (BaCrO_4) Fluoroelastomer
Intermediate Fire/Dip Coat	Polytetrafluorethylene (Teflon) ($-\text{C}_2\text{F}_4\text{]}_n - n=20,000$ units Magnesium (Mg) Fluoroelastomer
Assemblage (Residual Components)	
Aluminum Wrap	Mylar or filament tape bonded to aluminum tape
End Cap	Plastic (nylon)
Felt Spacers	Felt pads (0.25 inches by cross section of flare)
Piston	Plastic (nylon, tefzel, zytel)
<i>Source: Air Force 1997</i>	

Flare Ejection

Self-protection flares such as the MJU-7 and M-206 use an M-796 impulse cartridge (Air Force 1997). The flare is ignited in the aluminum case before it leaves the aircraft. Holes in the piston permit ignitor gases to contact the first fire mixture on top of the flare pellet. The parasitic type flare is less likely to produce duds. The plastic end cap falls to the ground following flare ejection. Flares are tested to ensure they meet performance requirements in terms of ejection, ignition, and effective radiant intensity. If the number of failures exceed the upper control quality assurance acceptance level (approximately 99 percent must be judged reliable), the flares are returned to the manufacturer. Table B-3 describes the components of M-796 impulse charges.

Table B-3 Components of M-796 Impulse Charges	
Component	M-796
Overall Size	0.449 x 0.530 inches
Overall Volume	0.104 cubic inches
Total Explosive Volume	0.033 cubic inches
Bridgewire	Trophet A 0.0025 inches (diameter)
Closure Disk	Scribed disc, washer
Initiation Charge	
Volume	0.011 cubic inches
Weight	100 mg
Compaction	5,500 psi
Composition	20% boron 80% potassium nitrate
Booster Charge	
Volume	0.011 cubic inches
Weight	70 mg
Compaction	5,500 psi
Composition	18% boron 82% potassium nitrate
Main Charge	
Volume	0.011 cubic inches
Weight	185 me
Compaction	Loose fill
Composition	Hercules HPC-1 (~40% nitrocellulose)
<i>Source: Air Force 1997</i>	

Policies and Regulations Addressing Flare Use

Air Force policy on flare use was established by the Airspace Subgroup of Headquarters (HQ) Air Force Flight Standards Agency (AFFSA) in 1993 (Memorandum from John R. Williams, 28 June 1993) (Air Force 1997). This policy permits flare drops over military-owned or controlled land and in Warning Areas. Flare drops are permitted in Military Operations Areas (MOAs) and Military Training Routes (MTRs) only when an environmental analysis has been completed. Minimum altitudes must be adhered to. Flare drops must also comply with established written range regulations and procedures.

AFI 11-214 prohibits using flare systems except in approved areas with intent to dispense, and sets certain conditions for employment of flares. Flares are authorized over government-owned and controlled property and over-water Warning Areas with no minimum altitude restrictions when there is no fire hazard. If a fire hazard exists, minimum altitudes will be maintained in accordance with the applicable directive or range order. An ACC supplement to AFI 11-214 (30 May 1997) prescribes a minimum flare employment altitude of 2,000 feet AGL over non-government owned or controlled property (Air Force 1997).

AFI 13-201, Air Force Airspace Management and AFI 13-212, Range Planning and Operations provide similar procedures for conducting training chaff and self-protection flare use in approved areas.

References

Air Force. 1997. *Environmental Effects of Self-Protection Chaff and Flares*. Prepared for Headquarters Air Combat Command, Langley Air Force Base, Virginia.

_____. 1999. *Description of the Proposed Action and Alternatives (DOPAA) for the Expansion of the Use of Self-Protection Chaff and Flares at the Utah Test and Training Range, Hill Air Force Base, Utah*. Prepared for Headquarters Air Force Reserve Command Environmental Division, Robins AFB, Georgia.

APPENDIX C

Interagency and Intergovernmental Coordination for Environmental Planning



DEPARTMENT OF THE AIR FORCE
HEADQUARTERS AIR COMBAT COMMAND
LANGLEY AIR FORCE BASE VIRGINIA

30 JUL 2003

MEMORANDUM FOR Mr. Gilbert Blue, Chairman
Catawba Indian Tribe
P.O. Box 188
Rock Hill SC 29704

FROM: HQ ACC/CEVP
129 Andrews Street, Suite 102
Langley AFB VA 23665-2769

SUBJECT: Proposed Chaff and Flare Usage in Military Operations Areas, Shaw Air Force Base (AFB), SC

1. The U.S. Air Force is in the process of preparing an Environmental Assessment to evaluate potential environmental impacts resulting from the proposed chaff and flare usage in two Military Operations Areas (MOAs): Bulldog MOA located in Georgia and Gamecock MOA located in South Carolina (map attached). The purpose of the proposal is to allow training with defensive countermeasures necessary for realistic training. This proposal would allow combat training with training chaff and flare for F-16 squadrons at the 20th Fighter Wing, Shaw AFB and McEntire Air National Guard Station, Columbia SC.

2. As part of the environmental analysis, the Air Force or its contractor, The Environmental Company, Inc. may contact you during data collection efforts. In advance, we thank you for your assistance in this activity. If you have any specific information or questions relative to this proposed training chaff and flare usage proposal, we would like to hear from you. In order to ensure that your feedback is included during preparation of the EA, your response is requested by 24 Sept 03.

3. Our point of contact for this project is Lt Van Allen at Shaw AFB Public Affairs at (803) 895-2025. We anticipate a draft EA will be made available for public and agency comment in Oct 03.

GILBERT N. BURNET, P.E.
Chief, Environmental Analysis Branch

1 Atch
Map

Global Power For America



DEPARTMENT OF THE AIR FORCE
HEADQUARTERS AIR COMBAT COMMAND
LANGLEY AIR FORCE BASE VIRGINIA

30 JUL 2003

MEMORANDUM FOR South Carolina Department of Natural Resources
Attn: John Frampton, Director
Rembert C. Dennis Building
1000 Assembly Street
Columbia SC 29201

FROM: HQ ACC/CEVP
129 Andrews Street, Suite 102
Langley AFB VA 23665-2769

SUBJECT: Proposed Chaff and Flare Usage in Military Operations Areas, Shaw Air
Force Base (AFB), SC

1. The U.S. Air Force is in the process of preparing an Environmental Assessment (EA) to evaluate potential environmental impacts resulting from the proposed chaff and flare usage in two Military Operations Areas (MOAs): Bulldog MOA located in Georgia and Gamecock MOA located in South Carolina. The purpose of the proposal is to allow training with defensive countermeasures necessary for realistic training. This proposal would allow combat training with training chaff and flare for F-16 squadrons at the 20th Fighter Wing, Shaw AFB and McEntire Air National Guard Station, Columbia SC.
2. We will add you to the mailing list for the EA as part of the environmental impact analysis process. If you have any specific questions, concerns or feel that it would be appropriate for your agency to serve as a cooperating agency on this EA, we would like to hear from you by 24 Sept 03. In addition, if you are aware of any ongoing or future actions that have potential cumulative effects with this proposal we would appreciate you identifying those actions. In advance, we thank you for your assistance in this activity.
3. Please contact the EA project Manager, Ms. Michele Cook at the above address or at (757) 764-9341. We anticipate a draft EA will be made available for public and agency comment in Oct 03.

GILBERT N. BURNET, P.E.
Chief, Environmental Analysis Branch

1 Atch
Map

Global Power For America



DEPARTMENT OF THE AIR FORCE
HEADQUARTERS AIR COMBAT COMMAND
LANGLEY AIR FORCE BASE VIRGINIA

30 JUL 2003

MEMORANDUM FOR: Georgia Department of Natural Resources
Attn: James Setser, Branch Chief, Program Coordination Branch
#2 Martin Luther King Drive
Floyd Building E, Tower Suite 1452
Atlanta GA 30334

FROM: HQ ACC/CEVP
129 Andrews Street, Suite 102
Langley AFB VA 23665-2769

SUBJECT: Proposed Chaff and Flare Usage in Military Operations Areas, Shaw Air
Force Base (AFB), SC

1. The U.S. Air Force is in the process of preparing an Environmental Assessment (EA) to evaluate potential environmental impacts resulting from the proposed chaff and flare usage in two Military Operations Areas (MOAs): Bulldog MOA located in Georgia and Gamecock MOA located in South Carolina. The purpose of the proposal is to allow training with defensive countermeasures necessary for realistic training. This proposal would allow combat training with training chaff and flare for F-16 squadrons at the 20th Fighter Wing, Shaw AFB and McEntire Air National Guard Station, Columbia SC.
2. We will add you to the mailing list for the EA as part of the environmental impact analysis process. If you have any specific questions, concerns or feel that it would be appropriate for your agency to serve as a cooperating agency on this EA, we would like to hear from you by 24 Sept 03. In addition, if you are aware of any ongoing or future actions that have potential cumulative effects with this proposal we would appreciate you identifying those actions. In advance, we thank you for your assistance in this activity.
3. Please contact the EA project Manager, Ms. Michele Cook at the above address or at (757) 764-9341. We anticipate a draft EA will be made available for public and agency comment in Oct 03.

GILBERT N. BURNET, P.E.
Chief, Environmental Analysis Branch

1 Atch
Map



DEPARTMENT OF THE AIR FORCE
HEADQUARTERS AIR COMBAT COMMAND
LANGLEY AIR FORCE BASE VIRGINIA

30 JUL 2003

MEMORANDUM FOR Historic Preservation Division/DNR
Attn: Mr. Lonice C. Barrett, Commissioner DNR
156 Trinity Avenue Southwest, Suite 101
Atlanta GA 30303-3600

FROM: HQ ACC/CEVP
129 Andrews Street, Suite 102
Langley AFB VA 23665-2769

SUBJECT: Proposed Chaff and Flare Usage in Military Operations Areas, Shaw Air Force Base
(AFB) SC

1. The U.S. Air Force is in the process of preparing an Environmental Assessment to evaluate potential environmental impacts resulting from the proposed chaff and flare usage in two Military Operations Areas (MOAs): Bulldog MOA located in Georgia and Gamecock MOA located in South Carolina. The purpose of the proposal is to allow training with defensive countermeasures necessary for realistic training. This proposal would allow combat training with training chaff and flare for F-16 squadrons at the 20th Fighter Wing, Shaw AFB and McEntire Air National Guard Station, Columbia SC.
2. We will use information collected for the EA to identify historic properties and consider them, if any. This information will be coordinated with your office according to the steps outlined in 36 CFR 800.3 through 36 CFR 800.7.
3. As part of the environmental analysis, the Air Force or its contractor, The Environmental Company, Inc. may contact you during data collection efforts. In advance, we thank you for your assistance in this activity. In addition, if your agency has recently completed, is currently implementing, or is planning to undertake any new activities which you believe should be included as part of our cumulative impact analysis, we ask you to identify the activity and provide a point of contact. If you have any specific questions relative to the proposed training chaff and flare usage, we would like to hear from you.
4. Please contact the EA Project Manager, Ms. Michele Cook at HQ ACC/CEVP, (757) 764-9341 or Lt Van Allen at Shaw AFB Public Affairs at (803) 895-2025. We anticipate a draft EA will be made available for public and agency comment in Oct 03.

GILBERT N. BURNET, P.E.
Chief, Environmental Analysis Branch

1 Atch
Map

Global Power For America



DEPARTMENT OF THE AIR FORCE
HEADQUARTERS AIR COMBAT COMMAND
LANGLEY AIR FORCE BASE VIRGINIA

30 JUL 2003

MEMORANDUM FOR State Historic Preservation Office
Department of Archives and History Center
Ms. Mary W. Edmonds, Deputy State Historic Preservation Officer
8301 Parkland Road
Columbia SC 29223-4905

FROM: HQ ACC/CEVP
129 Andrews Street, Suite 102
Langley AFB VA 23665-2769

SUBJECT: Proposed Chaff and Flare Usage in Military Operations Areas, Shaw Air Force Base (AFB) SC

1. The U.S. Air Force is in the process of preparing an Environmental Assessment to evaluate potential environmental impacts resulting from the proposed chaff and flare usage in two Military Operations Areas (MOAs): Bulldog MOA located in Georgia and Gamecock MOA located in South Carolina. The purpose of the proposal is to allow training with defensive countermeasures necessary for realistic training. This proposal would allow combat training with training chaff and flare for F-16 squadrons at the 20th Fighter Wing, Shaw AFB and McEntire Air National Guard Station, Columbia SC.
2. We will use information collected for the EA to identify historic properties and consider them, if any. This information will be coordinated with your office according to the steps outlined in 36 CFR 800.3 through 36 CFR 800.7.
3. As part of the environmental analysis, the Air Force or its contractor, The Environmental Company, Inc. may contact you during data collection efforts. In advance, we thank you for your assistance in this activity. In addition, if your agency has recently completed, is currently implementing, or is planning to undertake any new activities which you believe should be included as part of our cumulative impact analysis, we ask you to identify the activity and provide a point of contact. If you have any specific questions relative to the proposed training chaff and flare usage, we would like to hear from you.
4. Please contact the EA Project Manager, Ms. Michele Cook at HQ ACC/CEVP, (757)764-9341 or Lt Van Allen at Shaw AFB Public Affairs at (803) 895-2025. We anticipate a draft EA will be made available for public and agency comment in Oct 03.

GILBERT N. BURNET, P.E.
Chief, Environmental Analysis Branch

1 Atch
Map

Global Power For America



DEPARTMENT OF THE AIR FORCE
HEADQUARTERS AIR COMBAT COMMAND
LANGLEY AIR FORCE BASE VIRGINIA

30 JUL 2003

MEMORANDUM FOR Georgia State Clearinghouse
Attn: Ms. Barbara Jackson, SPOC
270 Washington Street, SW, 8th Floor
Atlanta, GA 30334

FROM: HQ ACC/CEVP
129 Andrews Street, Suite 102
Langley AFB VA 23665-2769

SUBJECT: Proposed Chaff and Flare Usage in Military Operations Areas, Shaw Air
Force Base (AFB) SC

1. The U.S. Air Force is in the process of preparing an Environmental Assessment (EA) to evaluate potential environmental impacts resulting from the proposed chaff and flare usage in two Military Operations Areas (MOAs): Bulldog MOA located in Georgia and Gamecock MOA located in South Carolina. The purpose of the proposal is to allow training with defensive countermeasures necessary for realistic training. This proposal would allow combat training with training chaff and flare for F-16 squadrons at the 20th Fighter Wing, Shaw AFB and McEntire Air National Guard Station, Columbia SC.
2. In accordance with Executive Order 12372, Intergovernmental Review of Federal Programs, we request your assistance by advising the appropriate state and local agencies of this proposal and soliciting their comments and identification of potential issues to be addressed in the EA. The environmental issues analyzed will be used in the decision-making process. Comments should be submitted no later than 24 Sep 03; however, comments received at anytime throughout the environmental impact analysis process will be considered to the extent possible in the preparation of the EA.
3. Anyone wishing to submit written comments may mail them to Ms. Michele Cook, EA Project Manager, Air Combat Command Environmental Analysis Branch, HQ ACC/CEVP, 129 Andrews Street, Suite 102, Langley AFB VA 23665-2769. For further information please contact Shaw AFB Public Affairs, Lt Van Allen at (803) 895-2025.

GILBERT N. BURNET, P.E.
Chief, Environmental Analysis Branch

1 Atch
Map



DEPARTMENT OF THE AIR FORCE
HEADQUARTERS AIR COMBAT COMMAND
LANGLEY AIR FORCE BASE VIRGINIA

30 JUL 2003

MEMORANDUM FOR South Carolina State Clearinghouse
Office of State Budget, Attn: Ms. Jean Manhiemer
1201 Main St., Suite 950
Columbia, SC 29201

FROM: HQ ACC/CEVP
129 Andrews Street, Suite 102
Langley AFB VA 23665-2769

SUBJECT: Proposed Chaff and Flare Usage in Military Operations Areas, Shaw Air
Force Base (AFB), SC

1. The U.S. Air Force is in the process of preparing an Environmental Assessment (EA) to evaluate potential environmental impacts resulting from the proposed chaff and flare usage in two Military Operations Areas (MOAs): Bulldog MOA located in Georgia and Gamecock MOA located in South Carolina. The purpose of the proposal is to allow training with defensive countermeasures necessary for realistic training. This proposal would allow combat training with training chaff and flare for F-16 squadrons at the 20th Fighter Wing, Shaw AFB and McEntire Air National Guard Station, Columbia SC.
2. In accordance with Executive Order 12372, Intergovernmental Review of Federal Programs, we request your assistance by advising the appropriate state and local agencies of this proposal and soliciting their comments and identification of potential issues to be addressed in the EA. The environmental issues analyzed will be used in the decision-making process. Comments should be submitted no later than 24 Sep 03; however, comments received at anytime throughout the environmental impact analysis process will be considered to the extent possible in the preparation of the EA.
3. Anyone wishing to submit written comments may mail them to Ms. Michele Cook, EA Project Manager, Air Combat Command Environmental Analysis Branch, HQ ACC/CEVP, 129 Andrews Street, Suite 102, Langley AFB VA 23665-2769. For further information please contact Shaw AFB Public Affairs, Lt Van Allen at (803) 895-2025.

GILBERT N. BURNET, P.E.
Chief, Environmental Analysis Branch

1 Atch
Map

Global Power For America



DEPARTMENT OF THE AIR FORCE
HEADQUARTERS AIR COMBAT COMMAND
LANGLEY AIR FORCE BASE VIRGINIA

30 JUL 2003

MEMORANDUM FOR U.S. Fish and Wildlife Service
North Georgia Field Office, Attn: Ms. Sandy Tucker
247 South Milledge Avenue
Athens GA 30605

FROM: HQ ACC/CEVP
129 Andrews Street, Suite 102
Langley AFB VA 23665-2769

SUBJECT: Proposed Chaff and Flare Usage in Military Operations Areas, Shaw Air
Force Base (AFB) SC

1. The U.S. Air Force is in the process of preparing an Environmental Assessment (EA) to evaluate potential environmental impacts resulting from the proposed chaff and flare usage in two Military Operations Areas (MOAs): Bulldog MOA located in Georgia and Gamecock MOA located in South Carolina. The purpose of the proposal is to allow training with defensive countermeasures necessary for realistic training. This proposal would allow combat training with training chaff and flare for F-16 squadrons at the 20th Fighter Wing, Shaw AFB and McEntire Air National Guard Station, Columbia SC.
2. The EA will analyze the potential effects of this proposed action on environmental resources. Pursuant to the Endangered Species Act and the National Environmental Policy Act, we are requesting information regarding federally listed or proposed species that may be present in the potentially affected area. If any of this information is available digitally, we would appreciate receiving it in that format. Until the extent of the potential impact to listed species is determined, we will make no decision regarding the need for a Section 7 consultation.
3. It is our understanding that your office will act as the single point of contact within the U.S. Fish and Wildlife Service for this action. Future correspondence will be directed to your office unless directed otherwise.
4. Please provide responses and direct inquiries on this matter to the EA Project Manager, Ms. Michele Cook at (757) 764-9341 (michele.cook@langley.af.mil).

GILBERT N. BURNET, P.E.
Chief, Environmental Analysis Branch

1 Atch
Map



DEPARTMENT OF THE AIR FORCE
HEADQUARTERS AIR COMBAT COMMAND
LANGLEY AIR FORCE BASE VIRGINIA

30 JUL 2003

MEMORANDUM FOR U.S. Fish and Wildlife Service
Regional Office
Attn: Mr. Sam Hamilton, Regional Director Southeast Region
1875 Century Boulevard, Suite 400
Atlanta GA 30345

FROM: HQ ACC/CEVP
129 Andrews Street, Suite 102
Langley AFB VA 23665-2769

SUBJECT: Proposed Chaff and Flare Usage in Military Operations Areas, Shaw Air
Force Base (AFB) SC

1. The U.S. Air Force is in the process of preparing an Environmental Assessment (EA) to evaluate potential environmental impacts resulting from the proposed chaff and flare usage in two Military Operations Areas (MOAs): Bulldog MOA located in Georgia and Gamecock MOA located in South Carolina. The purpose of the proposal is to allow training with defensive countermeasures necessary for realistic training. This proposal would allow combat training with training chaff and flare for F-16 squadrons at the 20th Fighter Wing, Shaw AFB and McEntire Air National Guard Station, Columbia SC.
2. The EA will analyze the potential effects of this proposed action on environmental resources. Pursuant to the Endangered Species Act and the National Environmental Policy Act, we are requesting information regarding federally listed or proposed species that may be present in the potentially affected area. If any of this information is available digitally, we would appreciate receiving it in that format. Until the extent of the potential impact to listed species is determined, we will make no decision regarding the need for a Section 7 consultation.
3. It is our understanding that your office will act as the single point of contact within the U.S. Fish and Wildlife Service for this action. Future correspondence will be directed to your office unless directed otherwise.
4. Please provide responses and direct inquiries on this matter to the EA Project Manager, Ms. Michele Cook at (757) 764-9341 (michele.cook@langley.af.mil).

GILBERT N. BURNET, P.E.
Chief, Environmental Analysis Branch

1 Atch
Map



DEPARTMENT OF THE AIR FORCE
HEADQUARTERS AIR COMBAT COMMAND
LANGLEY AIR FORCE BASE VIRGINIA

30 JUL 2003

MEMORANDUM FOR U.S. Fish and Wildlife Service
Ecological Services Field Office, Attn: Mr. Roger L. Banks
176 Croghan Spur Road, Suite 200
Charleston SC 29407-7558

FROM: HQ ACC/CEVP
129 Andrews Street, Suite 102
Langley AFB VA 23665-2769

SUBJECT: Proposed Chaff and Flare Usage in Military Operations Areas, Shaw Air
Force Base (AFB), SC

1. The U.S. Air Force is in the process of preparing an Environmental Assessment (EA) to evaluate potential environmental impacts resulting from the proposed chaff and flare usage in two Military Operations Areas (MOAs): Bulldog MOA located in Georgia and Gamecock MOA located in South Carolina. The purpose of the proposal is to allow training with defensive countermeasures necessary for realistic training. This proposal would allow combat training with training chaff and flare for F-16 squadrons at the 20th Fighter Wing, Shaw AFB and McEntire Air National Guard Station, Columbia SC.
2. The EA will analyze the potential effects of this proposed action on environmental resources. Pursuant to the Endangered Species Act and the National Environmental Policy Act, we are requesting information regarding federally listed or proposed species that may be present in the potentially affected area. If any of this information is available digitally, we would appreciate receiving it in that format. Until the extent of the potential impact to listed species is determined, we will make no decision regarding the need for a Section 7 consultation.
3. It is our understanding that your office will act as the single point of contact within the U.S. Fish and Wildlife Service for this action. Future correspondence will be directed to your office unless directed otherwise.
4. Please provide responses and direct inquiries on this matter to the EA Project Manager, Ms. Michele Cook at (757) 764-9341 (michele.cook@langley.af.mil).

A handwritten signature in black ink, appearing to read "Gilbert N. Burnet", is positioned above the typed name.

GILBERT N. BURNET, P.E.
Chief, Environmental Analysis Branch

1 Atch
Map



DEPARTMENT OF THE AIR FORCE
HEADQUARTERS AIR COMBAT COMMAND
LANGLEY AIR FORCE BASE VIRGINIA

30 JUL 2003

MEMORANDUM FOR U.S. Fish and Wildlife Service
Coastal GA Field Office, Attn: Mr. Strant Colwell
1835 Assembly Street, Room 378
Columbia SC 29201-2448

FROM: HQ ACC/CEVP
129 Andrews Street, Suite 102
Langley AFB VA 23665-2769

SUBJECT: Proposed Chaff and Flare Usage in Military Operations Areas, Shaw Air
Force Base (AFB) SC

1. The U.S. Air Force is in the process of preparing an Environmental Assessment (EA) to evaluate potential environmental impacts resulting from the proposed chaff and flare usage in two Military Operations Areas (MOAs): Bulldog MOA located in Georgia and Gamecock MOA located in South Carolina. The purpose of the proposal is to allow training with defensive countermeasures necessary for realistic training. This proposal would allow combat training with training chaff and flare for F-16 squadrons at the 20th Fighter Wing, Shaw AFB and McEntire Air National Guard Station, Columbia SC.
2. The EA will analyze the potential effects of this proposed action on environmental resources. Pursuant to the Endangered Species Act and the National Environmental Policy Act, we are requesting information regarding federally listed or proposed species that may be present in the potentially affected area. If any of this information is available digitally, we would appreciate receiving it in that format. Until the extent of the potential impact to listed species is determined, we will make no decision regarding the need for a Section 7 consultation.
3. It is our understanding that your office will act as the single point of contact within the U.S. Fish and Wildlife Service for this action. Future correspondence will be directed to your office unless directed otherwise.
4. Please provide responses and direct inquiries on this matter to the EA Project Manager, Ms. Michele Cook at (757) 764-9341 (michele.cook@langley.af.mil).

GILBERT N. BURNET, P.E.
Chief, Environmental Analysis Branch

1 Atch
Map

APPENDIX D

Agency Responses to Interagency and Intergovernmental Coordination for Environmental Planning

STATE OF SOUTH CAROLINA
State Budget and Control Board
OFFICE OF STATE BUDGET

MARK SANFORD, CHAIRMAN
GOVERNOR

GRADY L. PATTERSON, JR.
STATE TREASURER

RICHARD ECKSTROM
COMPTROLLER GENERAL



HUGH K. LEATHERMAN, SR.
CHAIRMAN, SENATE FINANCE COMMITTEE

ROBERT W. HARRELL, JR.
CHAIRMAN, WAYS AND MEANS COMMITTEE

FRANK W. FUSCO
EXECUTIVE DIRECTOR

1201 Main Street, Suite 950
COLUMBIA, SOUTH CAROLINA 29201
(803) 734-2280

LES BOLES
DIRECTOR

ACKNOWLEDGEMENT

August 5, 2003

Lt. Van Allen
Department of the Air Force
HQ ACC/CEVP
129 Andrews Street, Suite 102
Langley AFB, VA 23665-2769

Project Name: Proposed Chaff & Flare Usage in Military Operations Areas, Shaw Air Force Base (AFB), SC

State Application Identifier: **SC030705-414**

Suspense Date: **8/27/03**

Dear Dear Lt. Allen:

Receipt of the above referenced project is acknowledged. The Grant Services Unit, Office of State Budget, has initiated an intergovernmental review of this project. You will be notified of the results of this review by the suspense date indicated above.

All projects requiring intergovernmental review are posted on the project application bulletin located on the State Clearinghouse website at www.state.sc.us/OSB/. The bulletin, which is updated weekly, provides a listing of the projects along with pertinent project information. State agencies and Council of Government's will access the website bulletin and determine which project applications they wish to review. You will be responsible to provide a copy of the project application for their review.

South Carolina state agencies are reminded that if additional budget authorization is needed for this project, one copy of the completed GCR-1 form and one copy of the award documentation must be submitted to this office. This action should be initiated immediately, if required. Please include the State Application Identifier in any correspondence with our office regarding this project. If you have any questions please contact me at (803) 734-0494.

Sincerely,

A handwritten signature in cursive script that reads "Jean Manheimer".

Jean Manheimer
Fiscal Manager, Grant Services

South Carolina Department of
Natural Resources



John E. Frampton
Director

September 30, 2003

Ms. Michele Cook
Department of the Air Force
Headquarters Air Combat Command
HQ ACC/CEVP
129 Andrews Street, Suite 102
Langley AFB, VA 23665-2769

REF: Proposed Chaff and Flare Usage in Military Operations Areas
Shaw Air Force Base (AFB), SC

Dear Ms. Cook:

Personnel with the South Carolina Department of Natural Resources have reviewed the proposed project and evaluated its impact on natural resources and offer the following comments.

The proposed project consists of the usage of chaff and flares by the F-16 squadrons at the 20th Fighter Wing, Shaw AFB and McEntire Air National Guard Station. The military operations area in South Carolina consists of Berkeley, Clarendon, Florence, Georgetown, Marion and Williamsburg Counties. The purpose of the proposal is to allow training with defensive countermeasures necessary for realistic training.

We believe that the proposal will not substantially alter the quality of the environment, and we do not offer any objections at this time; however, we would like the opportunity to review the Environmental Assessment (EA) when it becomes available.

Sincerely,

A handwritten signature in black ink, appearing to read "Rob Duncan".

Robert E. Duncan
Environmental Programs Director

cc: Charee Hoffman

GEORGIA STATE CLEARINGHOUSE MEMORANDUM
EXECUTIVE ORDER 12372 REVIEW PROCESS

TO: Barbara Jackson
Georgia State Clearinghouse
270 Washington Street, SW, Eighth Floor
Atlanta, Georgia 30334

FROM: MR. RON METHIER
AIR PROTECTION BRANCH

SUBJECT: Executive Order 12372 Review

PROJECT: Draft EA/FONSI: Chaff & Flare Usage in Bulldog A/B and Gamecock B/C/D
MOAs at Shaw AFB

STATE ID: GA031016002

DATE: 11-7-03

- This notice is considered to be consistent with those state or regional goals, policies, plans, fiscal resources, criteria for developments of regional impact, environmental impacts, federal executive orders, acts and/or rules and regulations with which this organization is concerned.

This notice is not consistent with:

- The goals, plans, policies, or fiscal resources with which this organization is concerned. (Line through inappropriate word or words and prepare a statement that explains the rationale for the inconsistency. Additional pages may be used for outlining the inconsistencies).
- The criteria for developments of regional impact, federal executive orders, acts and/or rules and regulations administered by your agency. Negative environmental impacts or provision for protection of the environment should be pointed out. (Additional pages may be used for outlining the inconsistencies). [see attached]
- This notice does not impact upon the activities of the organization.

By William Muccis

Form SC-3
January 1995

RECEIVED

NOV 07 2003

GEORGIA
STATE CLEARINGHOUSE

Georgia Department of Natural Resources

205 Jesse Hill Jr., Drive, S.E., Suite 1152 East Tower, Atlanta, Georgia 30334-4100

Lonice C. Barrett, Commissioner

David M. Word, Assistant Director

Environmental Protection Division

(404)656-4713

November 3, 2003

Ms. Barbara Jackson
Georgia State Clearinghouse
270 Washington Street, SW, Eighth Floor
Atlanta, Georgia 30334

SUBJECT: Draft EA/FONSI: Chaff and Flare Usage in Bulldog A/B and
Gamecock B/C/D MOAs at Shaw AFB
GA031016002

Dear Ms. Jackson:

This is in response to the subject Draft EA/FONSI State ID# GA031016002, dated October 2003, seeking review and comment related to project-specific environmental concerns. If approved, this proposal will authorize the use of training chaff and self-protection flares in an airspace overlying Burke, Emanuel, Jefferson, Jenkins, Johnson and Washington counties in mid-eastern Georgia. The Draft EA/FONSI contained limited details covering the proposed combat training activities along with maps indicating the general location of the designated airspace. Potential environmental impacts from the proposed chaff and flare usage were noted to include, but were not limited to: land management, use and recreational resources; biological resources; soils and water; materials management; and environmental justice.

A careful review of the Draft EA/FONSI indicates that potential impacts to ambient air quality in the designated airspace were not properly assessed and reported. One or more of the counties that will be affected by the proposed activity is located within a Combined Metropolitan Statistical Area currently monitoring violations and/or near violations of the National Ambient Air Quality Standards for both ozone and fine particulate matter (PM_{2.5}).

As a result of the above, it is not clear as to whether the United States Air Force will be able to prevent adverse impacts and maintain air quality in the project area to the extent needed to properly protect human health and the environment.

Thank you for the opportunity to provide comment on this proposed action. If you have any questions, please contact Dr. Marlin Gottschalk of my staff at 404-657-5419.

Sincerely,

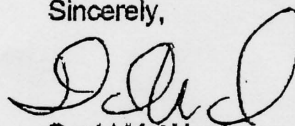

David M. Word
Assistant Director

CC:wem

cc: Marlin R. Gottschalk, GA EPD
Nap Caldwell, GA EPD
Ron Methier, GA EPD

RECEIVED

NOV 07 2003

GEORGIA
STATE CLEARINGHOUSE

Georgia Department of Natural Resources

Historic Preservation Division

Lonice C. Barrett, Commissioner

W. Ray Luce, Division Director and Deputy State Historic Preservation Officer
156 Trinity Avenue, S.W., Suite 101, Atlanta, Georgia 30303-3600
Telephone (404) 656-2840 Fax (404) 657-1040 <http://www.gashpo.org>

MEMORANDUM

TO: Gilbert N. Burnett
Chief, Environmental Analyst Branch
HQ ACC/CEVP
129 Andrews Street, Suite 102
Langley AFB, VA 23665-2769

FROM: Serena G. Bellew *SGB*
Environmental Review Coordinator
Historic Preservation Division

RE: Finding of "No Historic Properties Affected"

PROJECT: **Langley AFB: Chaff & Flare Usage, Bulldog Military Operations Area**
Federal Agency: Air Force
HP 030801-001

COUNTY: Washington County, Georgia

DATE: November 10, 2003

The Historic Preservation Division has reviewed the information received concerning the above-referenced project. Our comments are offered to assist federal agencies and project applicants in complying with the provisions of Section 106 of the National Historic Preservation Act.

Based on the information submitted, HPD has determined that no historic properties or archaeological resources that are listed in or eligible for listing in the National Register of Historic Places will be affected by this undertaking. Please note that historic and/or archaeological resources may be located within the project's area of potential effect (APE), however, at this time it has been determined that they will not be impacted by the above-referenced project. Furthermore, any changes to this project as proposed will require further review by our office for compliance with the Section 106 process.

If we may be of further assistance contact me at (404) 651-6624. Please refer to the project number assigned above in any future correspondence regarding this project.

SGB:mcv



OFFICE OF PLANNING AND BUDGET

Sonny Perdue
Governor

Timothy A. Connell
Director

GEORGIA STATE CLEARINGHOUSE MEMORANDUM EXECUTIVE ORDER 12372 REVIEW PROCESS

TO: Michele Cook
HQ ACC/CEVP
129 Andrews Street, Ste 102
Langley AFB, VA 23665-2769

FROM: Barbara Jackson
Georgia State Clearinghouse

DATE: November 25, 2003

SUBJECT: GA 031016002 -- Draft EA/FONSI: Chaff & Flare Usage in MOAs at Shaw AFB

Enclosed comments were received from the reviewing agency after the review period and after the project had been closed out. Although the reviewing agency may have already responded to you directly, I have gone ahead and sent you a copy of their comments for your files. We will retain a copy with our files also.

Thank you.

/bj

GEORGIA STATE CLEARINGHOUSE MEMORANDUM
EXECUTIVE ORDER 12372 REVIEW PROCESS

TO: Barbara Jackson
Georgia State Clearinghouse
270 Washington Street, SW, Eighth Floor
Atlanta, Georgia 30334

FROM: MR. WILLIAM D. BENNETT, EXECUTIVE DIRECTOR
SOIL & WATER CONSERVATION COMMISSION

SUBJECT: Executive Order 12372 Review

PROJECT: Draft EA/FONSI: Chaff & Flare Usage in Bulldog A/B and Gamecock B/C/D
MOAs at Shaw AFB

STATE ID: GA031016002

DATE: 11/19/03

- This notice is considered to be consistent with those state or regional goals, policies, plans, fiscal resources, criteria for developments of regional impact, environmental impacts, federal executive orders, acts and/or rules and regulations with which this organization is concerned.

This notice is not consistent with:

- The goals, plans, policies, or fiscal resources with which this organization is concerned. (Line through inappropriate word or words and prepare a statement that explains the rationale for the inconsistency. Additional pages may be used for outlining the inconsistencies).
- The criteria for developments of regional impact, federal executive orders, acts and/or rules and regulations administered by your agency. Negative environmental impacts or provision for protection of the environment should be pointed out. (Additional pages may be used for outlining the inconsistencies).
- This notice does not impact upon the activities of the organization.

We urge the utilization of conservation practices to minimize soil erosion during all phases of land-disturbing activities.

RECEIVED

NOV 25 2003

APPENDIX E

Federal Special-Status Species Potentially Found in
Counties Under the Proposed Action and Alternatives

APPENDIX E

FEDERAL SPECIAL-STATUS SPECIES POTENTIALLY FOUND IN COUNTIES UNDER THE PROPOSED ACTION AND ALTERNATIVES

Headquarters Air Combat Command mailed Interagency and Intergovernmental Coordination for Environmental Planning (IICEP) letters to federal and state agencies seeking comments on this Air Force proposal regarding special status species. A written response was received from the South Carolina State Clearinghouse. No other responses to the July 30, 2003 IICEP letters were received by September 29, 2003. In an effort to ensure that each IICEP recipient had an opportunity to respond to the proposal, the Air Force attempted contact with the remaining agencies by telephone on September 30, 2003. Personal contact was made with the IICEP recipients; of those contacted, three required that an additional copy of the IICEP letter be faxed to them.

In response to the calls and faxed letters, the South Carolina USFWS field office provided a species list by county (Appendix E), but no specific problems with the proposal were identified. The two remaining Georgia USFWS field offices stated that limited manpower requires that they will only review the draft EA and provide comments at that time. However, the Coastal Georgia USFWS field office expressed concern for the endangered wood stork in the Burke County area (under Bulldog B MOA) and for potential cumulative effects due to the Navy F-18 proposal in the same county. The USFWS Regional Office chose to delegate authority for the proposal to the field offices for evaluation of the EA. The South Carolina Department of Natural Resources had no objections to the proposal. No comments were received by the remaining agencies as of October 5, 2003.

All IICEP recipients were provided a copy of the draft EA for review and comment. By the end of the comment period—November 17—comments on the draft EA were only received from the Coastal Georgia USFWS field office and are found in Appendix E.



United States Department of the Interior

U.S. FISH AND WILDLIFE SERVICE

247 South Milledge Avenue
Athens, Georgia 30605

West Georgia Sub Office
P.O. Box 52560
Ft. Benning, Georgia 31995-2560

Coastal Sub Office
4270 Norwich Street
Brunswick, Georgia 31520

November 4, 2003

Mr. Gilbert N. Burnet, P.E.
Chief, Environmental Analysis Branch
Department of the Air Force
Headquarters Air Combat Command
Langley Air Force Base, Virginia 23665-2969
ATTN: Ms. Michele Cook, EA Project Manager

Re: FWS Log No. 03-0570

Dear Mr. Burnet:

The U.S. Fish and Wildlife Service (Service) has reviewed your letter which we received August 4, 2003 regarding potential environmental impacts resulting from the training flights in the Bulldog Military Operations Area (MOA) in Georgia by the 20th Fighter Wing of Shaw Air Force Base and McEntire Air National Guard Station, Columbia, SC. The purpose of the project is to allow combat training with chaff and flare usage for F-16 squadrons. We have also received the "Draft Shaw Air Force Base chaff and Flare Environmental Assessment" dated October 2003 and we are reviewing this document.

In your letter, you requested information on potential impacts to federally listed species that could occur in the Bulldog MOA in Georgia which involves Bulloch, Burke, Emanuel, Glascock, Jefferson, Jenkins, Johnson, Richmond, and Washington Counties. We have enclosed these county lists, which can be found at our website: athens.fws.gov.

Because of the high speed jet aircraft which may be flying at low altitudes, we are particularly concerned about federally listed wood storks and eagles that nest and frequently travel in the Bulldog A/B MOA. We have enclosed the 2003 data we have on the wood stork colonies and eagle nests that occur in this area. We have also enclosed a map of the wood stork foraging area for three wood stork rookeries and you will note that the foraging areas cover most of the Bulldog MOA.

Wood storks are large long-legged wading birds about 33 - 44 inches in height with a wingspan of 59 - 65 inches and weigh 5 - 8 pounds. In Georgia, breeding usually begins in March.

Incubation takes 27 - 32 days. Young storks begin learning to fly at about eight weeks of age. However, the young often remain at the colony and return to the nest to be fed by adults until around 12 weeks of age. Wood storks use a variety of feeding sites in both freshwater and estuarine wetlands to obtain adequate forage and fly long distances to feed and obtain food for the young.

Wood storks typically fly more like soaring hawks and vultures than like other birds, which flap their wings constantly. Although they can and do use standard flapping flight for short trips, they prefer to soar in convective currents or thermals, circling in these rising pockets of warm air to reach altitudes of 1000 - 3000 feet before gliding to their destination or the next thermal. By soaring, storks can travel as far as 30 - 40 miles to reach a feeding site with low energy cost to the birds. Storks often roost in habitat similar to where they nest, such as in trees surrounded by water. However, it is also common to find flocks of storks "resting" on mud flats and ground near feeding sites. These sites are probably "day roosts", where the storks are waiting before starting to feed depending on changing water levels or the activity of their prey. Many species of fish are more active and "catchable" at different times of the day.

Beginning in late summer, wood storks gather into communal roosts along the coast and may move out of the Bulldog MOA. According to the "Habitat Management Guidelines for the Wood Stork in the Southeast Region", there should not be any aircraft operation closer than 500 feet of a nesting colony. However, the safety of the pilots and aircraft should be considered with these large birds frequenting the Bulldog MOA from March to the late summer or early fall.

Bald eagles are 30 - 43 inches and have a wingspan of 72 - 98 inches and weigh from 8 - 12 pounds. Bald eagles almost always nest near open water, usually in a large open-topped pine, often on high ground if available. Eagles form permanent pair bonds and use a nest year after year. In Georgia, courtship and nest-building typically occur in October and November. Two to three eggs are then laid in December or January and are incubated for about 35 days. The eaglets fledge at about two weeks, typically in late March or April, but they remain under parental care for several more weeks. Adults bald eagles from Georgia are essentially non-migratory, but they might wander away from the nesting area until the next nesting season. Bald eagles from the northern United States will migrate down to Georgia in the winter. The most critical time for eagles is during nesting, which occurs in the winter.

According to the "Habitat Management Guidelines for the Bald Eagle in the Southeast Region", the Primary Zone is the most critical area for nesting eagles. Fixed wing aircraft operation within 500 feet vertical distance or 1000 feet horizontal distance from a nest would likely be detrimental while eagles are present and, therefore, should be restricted in the Primary Zone during the nesting period, but not necessarily during the non-nesting period.

The Secondary Zone for bald eagles is from the Primary Zone to one mile. Low level aircraft operations should only take place in this zone during the non-nesting period.

This information covers the two most obvious federally listed species that could be affected by these training flights. However, the nine county lists should be used to determine if there is habitat that could be used by any of the other federally listed species in carrying out these training missions.

We appreciate the opportunity to comment on these training exercises which could occur in the Bulldog MOA. We will be providing comments on the Draft EA. We will be the point of contact on section 7 consultation regarding use of the Bulldog MOA. However, we would appreciate receiving courtesy copies of correspondence to our Charleston Ecological Services office regarding the Gamecock MOA, also. If you have any questions or require further information, please contact staff biologist Kathy Chapman at 912-265-9336 ext.24. or email kathy_chapman@fws.gov.

Sincerely,

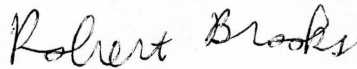

 Sandra S. Tucker
Field Supervisor

Enclosures

cc:

FWS, Athens, Georgia

FWS, Charleston, SC (Phil DeGarmo)

Wood Storks

The generally accepted explanation for the decline of the wood stork as a U.S. breeding species is the reduction in the food base (primarily small fish) necessary to support breeding colonies. This reduction is attributed to loss of wetland habitat as well as to changes in hydroperiods. (excerpt from Recovery Plan).

Wood storks feed, to a large extent, on small, freshwater fish, which usually range in length between 2.0 and 25 cm. Because of the stork's specialized gape-feeding technique for capturing fish works most efficiently where fish densities are high, much foraging occurs at sites where fish have become concentrated by dropping water levels. Characteristically, good feeding sites are those with still or very slow flowing water at depths of between about 5 and 30 cm. Since storks locate fish primarily by feel rather than by sight, good foraging sites can be either clear or muddy, or may contain appreciable amounts of submerged or emergent vegetation. The only important constraint with vegetation is that it not be so dense as to interfere with a stork's movements as it makes repeated probes into the water with its bill.

Many wetland sites may provide suitable foraging areas, including drying roadside ditches, isolated tidal pools exposed by dropping tides, drying depressions in marshes or wooded swamps, edges of farm ponds, edges or shallows in streams during low water periods, natural wet grasslands, or seasonal ponds in pastures. Suitable feeding sites are not known to have specific requirements in terms of water quality or site location, so long as the basic water depth, water stillness and fish density are appropriate. Some foraging sites may only be seasonally flooded, and most are only suitable to foraging storks during periods of the year when fish are concentrated. Thus, falling water levels may be essential at many locations as a mechanism to concentrate fish. Conversely, during periods of heavy rainfall, or whenever levels are rising, fish densities in many pools may not be high enough to attract storks.

Most stork nesting colonies are located in regions with relatively large numbers of wetland sites within a 40 mile radius of the colony. Storks utilize many different feeding sites during the course of a nesting season and to nest successfully, they may be required to nest in regions where the number of feeding site options are high. The smaller feeding sites may be cleaned out by a number of storks in only a day, requiring that these birds locate a new feeding site the next day. It is also important that there be enough diversity in wetland habitats within range of a colony so that the proper water depths and fish densities are available at several sites at any time during the 4 to 5 month nesting cycle. In some regions, this requirement is met through a complex mosaic of many small pools, sloughs, ditches, and secondary creeks woven throughout a flat or low-rolling landscape. In the Everglades and Big Cypress regions of south Florida, uneven drying rates caused by subtle differences in marsh depth and the presence of deeper "gator holes" and sloughs, provide a prolonged period of suitable feeding conditions for storks. During early winter in Florida, when water levels are still too deep in interior marshes, storks feed almost exclusively in more coastal mangrove swamps and tidal pools. As the winter dry season progresses, storks gradually move further and further inland, essentially following the drying edge, and concentrating their feeding effort in many isolated pools where fish are trapped by the dry-down. Such a condition apparently once provided the ideal feeding habitat capable of supporting large number of wood storks and why there were large nesting colonies in southern Florida.

TABLE 1: KNOWN WADING BIRD COLONIES SURVEYED FOR WOOD STORKS BY AIRCRAFT IN 2003

20	RTOC - Mission Forest	Camden				Location Questionable, did not survey
21	Cravens Hammock*	Charlton	21-z		6-May-03	Water but no birds
22	Little Buffalo Creek*	Charlton	23-z		6-May-03	GREG, other waders
23	Gum Slough	Charlton	22-z		6-May-03	water but no birds, drop from list in 04
24	St. Marys River	Charlton				Did not survey
25	Ossabaw Egret Pond	Chatham	13		5-May-03	no nesting but plenty of water
26	Ossabaw Middle Place	Chatham	12		5-May-03	GREG, SNEG, TCHE, BCNH, 20 loafing WOST
27	Ossabaw Hog Pond*	Chatham	14		5-May-03	water but no birds nesting
28	Ossabaw	Chatham	11		5-May-03	some water
29	Little Tybee Beach Hammock	Chatham	16		5-May-03	5 GREG
30	Wassaw	Chatham	15		5-May-03	water but no birds nesting
31	Savannah Yacht Club	Chatham	19		5-May-03	85 GREG, 20 GTBH
32	Burnt Pot Island	Chatham	18		5-May-03	GREG, GTBH
33	Skidaway Island Landings*	Chatham	17		5-May-03	45 WOST, GREG, SNEG, 6 DCCO, BCNH
34	Burroughs	Chatham	23		5-May-03	no birds
35	Blue Pond	Crisp/Wilcox				Did not survey
36	Lukes Pond?*	Colquit				did not survey
37	Cypress Lake	Dodge			11-May-03	Audubon IBA day syrvey, no WOST, 5,000 pr waders
38	Martin Branch	Echols	19-z			skipped, in Moody Airspace
39	Durden's Pond	Emanuel	22		5-May-03	water and birds nesting, GREG, SNEG, ANHI, GTBH, Tortoises near site

¹Data provided by Larry Bryan, Savannah River Ecology Lab

²Data provided by John Robinette, USFWS

*Historical or present wood stork rookery site

**New Wading Bird Location

TABLE 1: KNOWN WADING BIRD COLONIES SURVEYED FOR WOOD STORKS BY AIRCRAFT IN 2003

40	St. Simons Island*	Glynn	3	5-May-03	71 WOST, GREG, TRCH, BCNH, ANHI
41	St. Simons II*	Glynn		5-May-03	68 WOST, GREG, TRCH
42	Harrington Pond*	Glynn	1	5-May-03	no birds nesting
43	Little St. Simons Island*	Glynn	4a	5-May-03	No birds at coordinates, but nesting in slough on south end and in flooded field nw part of island
44	Jekyll Island Golf Course*	Glynn		5-May-03	26 pair in one dead pine tree.
45	Spivey Pond	Glynn		5-May-03	SNEG, GREG, LBHE
46	Big Dukes Pond**	Jenkins			87 WOST surveyed by L. Bryan
47	Chew Millpond**	Jenkins			135 WOST surveyed by L. Bryan
48	River Bend WMA	Laurens			Unknown location drop from list
49	Colonel's Island Youman's Pond	Liberty	26	5-May-03	water but no nesting
50	Colonel's Island Drum Point	Liberty	25	5-May-03	full of water but no nesting in willows
51	Riceboro	Liberty	25a	5-May-03	lots of nesting, DCCO, GREG, SNEG, TCHE, LBHE,
52	St. Catherines Windmill Pond*	Liberty	10	5-May-03	GREG
53	St. Catherines Wamassee Pond	Liberty	9-Jan	5-May-03	SNEG
54	Sunbury-A*	Liberty	24	5-May-03	water no nesting
55	Malcolm's Rookery*	Long	27	5-May-03	8 WOST, other waders
56	Jumping Gully	Lowndes	18z	5-May-03	300 CAEG, 200 LBH
57	Mud Swamp	Lowndes	17z	5-May-03	Water and birds nesting Bog area
58	Hahira*	Lownes			Did not survey
59	Creighton Island-A	McIntosh	29	5-May-03	water, no birds

¹Data provided by Larry Bryan, Savannah River Ecology Lab

²Data provided by John Robinette, USFWS

*Historical or present wood stork rookery site

**New Wading Bird Location

TABLE 1: KNOWN WADING BIRD COLONIES SURVEYED FOR WOOD STORKS BY AIRCRAFT IN 2003

60	Creighton Island-B	McIntosh	30	5-May-03	water, 1 GTBH, 1 GREG
61	Slivka*	McIntosh	28	5-May-03	26 WOST , GREG
62	Harris Neck NWR ²	McIntosh			431 WOST , surveyed by J. Robinette, USFWS
63	Marys Hammock	McIntosh	4b	5-May-03	dry
64	Patterson Island*	McIntosh	31	5-May-03	some water
65	Sapelo Island-Cabretta	McIntosh	5	5-May-03	dry
66	Sapelo Island-Tanner	McIntosh	6	5-May-03	GREG, SNEG
67	Sapelo Island-Duck Pond	McIntosh	7	5-May-03	Very low water, no birds
68	Sapelo South End Creek*	McIntosh		5-May-03	10 WOST
69	Lewis Island*	McIntosh	33	5-May-03	
70	Ardick	McIntosh			Did not survey
71	Blackbeard Island*	McIntosh	8	5-May-03	20 GREG and SNEG
72	Tolomato Pond	McIntosh	32	5-May-03	no nesting, pond has gone saline, nesting shrubs gone
73	Lee Pond	Screven			coordinates off, could not find
74	Jacobson's Landing*	Screven		5-May-03	
75	Heard's Pond*	Thomas	9z	6-May-03	no birds, storks to the south in Halls Pond
76	Hall's Pond below Heard's*	Thomas	11z		65 WOST
77	Thomasville Airport	Thomas	10z	6-May-03	Water, feeding WOST and GREG
78	Paulks Pond?	Turner?			Did not survey
79	Sand Creek Pond**	Turner/Irwin			did not survey

¹Data provided by Larry Bryan, Savannah River Ecology Lab

²Data provided by John Robinette, USFWS

*Historical or present wood stork rookery site

**New Wading Bird Location

Eagle Nests 2003

no. fledged

ID	Location	County	no. fledged
44	Clarks Hill east2 H	McDuffie	OCC
45	Fort Benning I	Chattahoochee	
46	Fort Benning west I	Chattahoochee	1
47	Little St. Simons	Glynn	2
48	Woods Cut	McIntosh	2
49	Union Camp	McIntosh	OCC
50	IP Southlands HQ	Decatur	1
51	Moss Island	Liberty	1
52	Banks Lake	Lanier	
53	Carters Lake	Murray	OCC
54	Lake Blackshear	Lee	2
55	Grassy Pond	Lowndes	1
56	Millpond	Thomas	1
57	Allatoona	Cherokee	2
58	West Point Antioch	Troup	2
59	West Point 219	Troup	
60	Goat Rock Mulberry	Harris	OCC
61	Williams Bluff	Early	
62	Williams Bluff2	Early	1
63	River Junction L	Decatur	
64	Spring Creek east J	Decatur	OCC
65	Spring Creek west J	Seminole	
66	Pretoria	Dougherty	1
67	Forest City Gun Club K	Chatham	
68	Vernonburg K	Chatham	2
69	Ossabaw (South end)	Chatham	OCC
70	Clarks Hill Mistletoe M	Columbia	
71	Reynolds Plantation	Greene	1
72	Hartwell Dam	Hart	1
73	Bay Meadows	Coffee	OCC
74	Spring Creek mouth	Decatur	1
75	Lake Nottely	Union	
76	Clarks Hill Graball R	Lincoln	
77	Hesters Ferry R	Lincoln	
78	Hesters Ferry2 R		1
79	Baileys Mill	Camden	(1x) 1
80	Ford Plantation	Bryan	
81	River Hill S	Early	
82	River Hill 2 S	Early	OCC
83	Sinclair T	Hancock	
84	Cumberland Island	Camden	1
85	Long Pond	Lowndes	1
86	Bussey Point	Lincoln	
87	Louisville	Jefferson	2

Eagle Nests 2003

no. fledged

88	Sea Island	Glynn	31 12	3.00		3
89	Clarks Hill Woodlawn M	Lincoln	33 40	4.47		
90	Goat Rock North	Harris	32 34	3.92	OCC	
91	Seminole west	Seminole	30 45	3.78		
92	Little Tybee Island	Chatham	31 54	4.53	OCC	
93	Big Haynes Creek	Rockdale	33 44	3.53		
94	Sinclair Dam T	Baldwin	32 08	2.5		
95	Kolomoki Creek	Early	31 31	2.00		2
96	Cow Island	McIntosh	31 21	3.72		2
97	Harris Neck	Liberty	31 33	3.47		2
98	Bateau Pond	Decatur	30 58	3.59		2
99	Sapelo	McIntosh	31 28	3.58		1
100	Wassaw	Chatham	31 53	3.98	OCC	
101	Lebanon Plantation	Chatham	32 01	2.82		2
102	Plant Wansley U	Heard	33 25	2.63		
103	Wansley south U	Heard	33 24	3.98		1
104	Cool Branch V	Quitman		3.40	OCC	
105	Cool Branch north V	Quitman	31 50	7.00		
106	Murray Creek	Lincoln	33 53	3.70		
107	Murray Creek 2	Lincoln	33 52	3.23	OCC	
108	Broad River	Lincoln	33 57	3.80		
109	Broad River2	Wilkes	33 58	3.05		2
110	Aucilla Plantation	Thomas	30 48	3.14		1
111	Horse Stomp	Camden	31 04	3.20		1
112	Lake Oconee Cold Springs	Greene	33 38	3.37		2
113	Lake Sinclair 3 T	Baldwin	33 10	3.71		2
114	Oconee Reynolds south??	Greene	33 7	1.9		
115	Bowden's Pond	McDuffie		4.01		1
116	Modena Island	Chatham	31 59	3.88		2
117	River View	Harris	32 47	3.13		2
118	Hopulikit	Bulloch	32 30	3.35		1
119	Southlands north	Decatur	30 47	3.34		2
120	West Point WMA west	Heard	33 09	4.87		2
121	Creighton Island	McIntosh	31 30	3.69		
122	Eufaula Bagby	Clay	31 41	4.04		3
123	Big Lazer WMA	Talbot	32 48	3.48		2
124	Moody Forest	Appling	31 59	7.28		
125	Camp Pasture	Seminole	30 51	3.59		1
126	Wingate East	Decatur	30 46	3.22	OCC	
127	Myrtle Grove	Bryan	31 53			1
128	Ocean Pond	Lowndes	30 39			2
129	Harrietts Bluff	Camden	30 51	3.52		1
130	Soapstone Creek	Quitman	31 57	3.15		2
131	Kolomoki Plantation	Early	31 29	3.81		1