

H-14  
30001300

M-U 43122

T125c

30001300



CHAOS IN WAR:  
IS IT PRESENT AND WHAT DOES IT MEAN?

BY

NOTICE: This material may be  
protected by copyright law  
(Title 17 U.S. Code)

TODOR TAGAREV

MICHAEL DOLGOV

DAVID NICHOLLS

RANDAL C. FRANKLIN

PETER AXUP

Submitted to the Air Command and Staff College  
in fulfillment of the requirement  
of the AY94 Research Program

June 1994

20101015390

10429794

## BIOGRAPHIES

Peter Axup: Major Axup received his commission in the United States Air Force through the Reserve Officer Training Corps in 1980. He served two tours in research and development, one tour in operational testing, and one tour in depot logistics engineering. Major Axup completed both Squadron Officer School and Air Command and Staff College by correspondence.

Michael Dolgov: Major Dolgov received his commission in the Soviet Union Air Force from the Kiev Air Force Engineering Academy in 1984, along with a graduate degree in Electronic Engineering. From 1984 through 1993, he served successively as a Junior Research Fellow and a Senior Research Fellow in the Russian Air Force Research Institute. He has six technical publications to his credit.

Randal C. Franklin: Major Franklin received his commission in the United States Air Force through Officer Training School in 1981. He received his Bachelor of Science in electrical engineering from the Air Force Institute of Technology in 1983. His most recent tour was with the Air Force Operational Test and Evaluation Center at Kirtland Air Force Base, New Mexico. Following Air Command and Staff College, he will be assigned to the 26th Operations Support Squadron at Vogelweh Army Installation, Germany.

David Nicholls: Major Nicholls received his commission in the United States Air Force through Officers Training School in 1980. After an initial tour performing and managing research at the Air Force Materials Laboratory, he was assigned as an instructor in the Department of Engineering Mechanics at the Air Force Academy. Three years later, he was selected to attend Oxford University. After earning his Doctorate in materials engineering, he returned to teach again at the Academy. In this tour, he was selected as the Outstanding Military Educator in Engineering Mechanics for 1991 and as a Dow Outstanding Young Faculty Member for the American Society for Engineering Education for 1992. He has fifteen technical publications to his credit.

Todor Tagarev: Upon graduation from the Bulgarian Air Force Academy in 1982, Major Tagarev received his commission in the Bulgarian Armed Forces and his graduate degree in Automatics and Telemechanics. From 1982 until 1986, he served as a weapon

systems maintenance specialist. From 1986 until 1989, he was a postgraduate student at the N. E. Joukovsky Air Force Engineering Academy in Moscow, Russia. After the defense of his dissertation, he served as a lecturer at the Bulgarian Air Force Academy. In 1991, he was appointed Deputy Head of the Scientific Research Department at the Academy. Prior to his studies at ACSC, Major Tagarev worked as a military education specialist for the Personnel Department of the Bulgarian Ministry of Defense. Major Tagarev has over twenty publications in systems control.

## ABSTRACT

Chaos theory has been applied to numerous areas in the physical and social sciences. Research into areas such as strategic decision making and arms control indicate that chaos theory may apply to conflict and warfare. Other research projects have examined arms control war games for chaotic behavior and used chaos theory to describe Clausewitzian friction in warfare. However, none of this research has examined data associated with past wars to see if chaos is actually present. The objective of this research was to apply several techniques to warfare that have been used to determine the presence of chaos in other fields and to explore the implications of the presence of chaos to warfare.

The data used for this research included aircraft loss data for the entire Vietnam War, Allied casualty data for their advance through western Europe during World War II, and historical US defense spending. These data were selected because they represent several levels of war and include interaction with an enemy. In addition, they reflect an output of the process of war. Because of their importance, they are reliable and documented parameters. The specific tests used in this work were the autocorrelation function, the power spectrum, the fractal dimension, and the Poincare map.

The results of this work indicated that chaos is, in fact, present in warfare. The implications of this result include

determinism in warfare, the applicability of computer simulation, dynamism of warfare, nonlinearity in warfare, the applicability of fractal geometries, and the possibility of multiple attractors. These implications are explored for their meaning in the context of warfare.

## ACKNOWLEDGMENTS

*Chaos doesn't acknowledge science, which is linear,  
but it might acknowledge people, who are nonlinear.*

Anonymous

Our appreciation goes to:

LTC Liby and Maj Burg of the Air Command and Staff College faculty for proposing the project and laying the foundation for our research.

Maj Scott Goehring, Maj Mike Bland, and Capt Paul Titorenko of the CADRE Wargaming Center for supporting us in exploring the ACES wargame as an avenue for research.

CDR Sarigul-Klijn, formerly at the Naval Postgraduate School, for processing some of our data with the software he developed for his dissertation. He confirmed the validity of our software and provided us with the Poincare maps and the power spectrum.

LTC Pentland of the School for Advanced Aerospace Studies for his challenging discussions on the fruitful potential of applying chaos theory to warfare.

George Kuhn of the US Army's Logistics Management Institute for providing us with the casualty data for the 12th Army Group in World War II.

## OUTLINE

Page	
	BIOGRAPHIES ..... ii
	ABSTRACT ..... iv
	ACKNOWLEDGMENTS ..... vi
	OUTLINE ..... vii
	LIST OF FIGURES ..... ix
	CHAOS IN WAR: IS IT PRESENT AND WHAT DOES IT MEAN? ..... 1
I.	Introduction ..... 1
A.	Review Of Chaos ..... 2
1.	An Overview Of How Systems Change With Time ... 2
2.	Concepts And Terminology In Chaos Theory ..... 5
3.	Population Levels As An Example Of A Chaotic System ..... 10
4.	Applications Of Chaos Theory ..... 13
B.	Goals Of Research ..... 16
II.	Tests For Identification Of Chaotic Behavior In Experimental And Historical Data ..... 18
A.	Introduction ..... 18
B.	Qualitative Criteria For Chaotic Behavior ..... 19
1.	Time Dependence ..... 19
2.	Autocorrelation Function ..... 20
3.	Power Spectrum ..... 21
4.	Poincare Maps ..... 22
C.	Quantitative Criteria For Identification Of Chaotic Behavior ..... 25
1.	Lyapunov Exponents ..... 25
2.	Correlation Dimension ..... 28
3.	Kolmogorov-Sinai Entropy ..... 29
4.	Relation Between The Methods For Quantitative Description Of Chaos ..... 30
5.	Error Estimation And Data Requirements ..... 31
III.	Warfare Data ..... 33
A.	Introduction ..... 33
B.	Data Characteristics ..... 33
C.	Potential Data Sources ..... 34
1.	Historical Data ..... 34
(A)	Grand Strategic Level Of War ..... 35
(B)	Strategic Level Of War ..... 36
(C)	Operational Level Of War ..... 36
(D)	Tactical Level Of War ..... 37
2.	Wargames ..... 37
(A)	Purpose ..... 37

- (B) Selection Of ACES ..... 38
- (C) Description Of ACES ..... 38
- (D) Data Available From ACES ..... 39
- (E) Problems Using ACES ..... 39
- D. Data Used For Chaotic Behavior Analysis ..... 40
  - 1. US Fixed-Wing Aircraft Losses During The Vietnam War, 1962-1973 ..... 40
  - 2. US Army Casualties In Western Europe During World War II ..... 44
- IV. Identification Of Chaotic Behavior ..... 45
  - A. Reliability Of The Tests For Identification Of Chaotic Behavior ..... 45
  - B. Chaotic Behavior On The Grand Strategic Level .... 47
  - C. Chaotic Behavior On The Strategic Level: US Aircraft Losses In Vietnam ..... 50
  - D. Chaotic Behavior On The Operational Level: WWII Casualties ..... 54
- V. Implications Of The Presence Of Chaos In Warfare ..... 57
  - A. Chaotic Systems Are Deterministic ..... 57
  - B. Computer Simulation Can Greatly Enhance Our Understanding ..... 59
  - C. Chaotic Systems Are Dynamic ..... 63
  - D. Chaotic Systems Are Nonlinear ..... 65
  - E. Fractal Geometries Apply ..... 69
  - F. Multiple Attractors Are Possible ..... 71
- VI. Conclusions ..... 73
- APPENDIX ..... 74
- ENDNOTES ..... 83
- BIBLIOGRAPHY ..... 88

## LIST OF FIGURES

Figure	Page
1.	Illustration of phase space for a pendulum ..... 6
2.	The Lorenz attractor ..... 7
3.	The Koch snowflake ..... 9
4.	Variation of population level ..... 11
5.	Representative magnified view of region C from Figure 4 . 13
6.	Time series generated by the Henon map ..... 19
7.	Divergence from nearly identical initial conditions for the logistics equation ..... 20
8.	Poincare map ..... 22
9.	Phase-space trajectories of chaotic systems ..... 23
10.	Schematic representation of the Wolf algorithm to compute $\lambda_1$ ..... 26
11.	$\ln C(r)$ versus $\ln r$ for the Lorenz system ..... 46
12.	Time dependence of US defense expenditures (FY87\$) as a percentage of both GNP and federal outlays ..... 47
13.	Phase space trajectory for defense spending as a percentage of GNP ..... 48
14.	Fractal dimension versus embedding dimension for US defense spending as a percentage of both GNP and federal outlays ..... 49
15.	Data generated by the arms race model ..... 49
16.	Autocorrelation function of the time series representing US aircraft losses in Vietnam ..... 50
17.	Power spectrum for the aircraft losses in Vietnam ..... 51
18.	Time dependence of the US aircraft losses in Vietnam .... 52
19.	$\ln C(r)$ versus $\ln r$ for weekly aircraft losses in Vietnam... 52
20.	Estimated fractal dimension for weekly US aircraft losses (as a whole and in the air) ..... 53
21.	Comparison between the estimated fractal dimensions for weekly and monthly aircraft losses (all causes) ..... 54
22.	Normalized US Army casualties in WWII (trajectory in two- dimensional phase space, constructed by a time delay of five days) ..... 55
23.	Poincare map for the normalized WWII casualties. .... 56
24.	Convergence of the estimated fractal dimensions for three sets of 196 data points for WWII casualties ..... 56

## CHAOS IN WAR: IS IT PRESENT AND WHAT DOES IT MEAN?

### I. INTRODUCTION

For the last thirty years, the study of chaos has intrigued investigators, prompting visionaries to see a great future for the study and application of chaos theory. Within the past year, investigators demonstrated that chaos theory yielded tangible results in an engineering situation where conventional control techniques were lacking.<sup>1</sup>

Because of the high stakes in war, every advantage is sought and no stone left unturned in the quest for quick victory at minimal cost. Although chaos theory is still young, investigators are already attempting to apply it to the study and conduct of war. Some studies focused on the grand strategic level of decision making, while others pursued philosophical application to war in general.

Last year, a group at the Air Command and Staff College produced a primer on chaos theory.<sup>2</sup> They surveyed the literature for ideas on applying chaos theory to the operational level of war, the theater campaign. This year, we are building on that study. In particular, we attempted to prove that chaos exists in the operational level of war by applying mathematical tests to historical data.

This paper provides an overview of chaos theory, followed by a discussion of the mathematical underpinnings of the tests we used. Then we discuss the types of historical data that

were available and the ones we selected for our investigation. We also discuss chaos theory in the context of theater level wargames. Next, we present the results of the tests, and follow this with the theoretical implications of the presence of chaos in war. In the appendix, we present the software used for computation of the autocorrelation function and the fractal dimension.

#### **A. REVIEW OF CHAOS**

The main purpose of this section is to provide the reader with a basic understanding of what chaos is. Defining chaos is complicated by the fact that the common definition of chaos as "a state of utter confusion or disorder"<sup>3</sup> is different from the technical use of the word. On the other hand, scientific definitions of chaos use specialized jargon. For example, chaos has been defined as "the complicated, aperiodic, attracting orbits of certain (usually low dimensional) dynamical systems."<sup>4</sup> To clarify this jargonistic definition, we must briefly discuss chaos theory and its applications. This will include an overview of how systems change with time, some of the major concepts and terminology of chaos theory, an example of a chaotic system, and a summary of where chaos theory has been applied.

##### **1. AN OVERVIEW OF HOW SYSTEMS CHANGE WITH TIME**

If a system changes with time it is, by definition, dynamic rather than static. Dynamic systems differ from one another in

how they change with time. In random systems, future behavior is independent of the initial state of the system and can be characterized only in terms of probabilities. Unless dice are loaded, the next roll of the dice is totally independent of the previous roll. On the other hand, periodic systems return regularly to the same conditions -- as exemplified by the pendulum clock. Such systems are totally predictable, because once one period is known, all others must be identical. Chaotic systems are neither random nor periodic. They are not random because the future of a chaotic system is dependent upon initial conditions. They are not periodic because their behavior never repeats.

Chaotic systems never repeat exactly because their future behavior is extremely sensitive to initial conditions. Thus, infinitesimal differences in initial conditions eventually cause large changes in system behavior. An often used example of this sensitivity is weather. Weather is so sensitive to initial conditions that it is thought that the flap of a butterfly's wings in America could eventually cause a typhoon in China.<sup>5</sup> It is inconceivable that conditions on the Earth could ever duplicate an earlier time to the point where even all butterflies' flights are duplicated. Therefore, the Earth's weather will never be periodic.

In addition to making chaotic systems aperiodic, extreme sensitivity to initial conditions means that it is not possible to determine the present conditions exactly enough to fully predict what that future will be. Short term predictions are

still possible because small influences will not have had time to grow to large ones. What is short term, however, is relative and is a function of how sensitive the system is to small changes at that point in time.

The lack of predictability in chaotic systems is important because our society's technology depends heavily on predictability. We need to know, among other things, that buildings will not fall, that electrical components will be safe, and that aircraft won't fall out of the sky. The list of our concerns is endless. The lack of predictability would still be of only academic interest if few systems were chaotic. As will become apparent with the examples throughout this section, however, chaotic behavior is quite common.

The next section will define several concepts and terms that are used in chaos theory. Before doing that, two points should be clarified. First, the preceding paragraphs discussed chaotic systems, periodic systems, and random systems as though they were always totally separate. This is not strictly true. A single system can, for example, be chaotic for certain conditions and periodic for others. Such a system is described later in section I.A.3. When the term "chaotic system" is used in this paper, we mean a system that is in a chaotic regime.

The second point that needs clarification is what we mean by determinism. Determinism in this paper means that the future of a system is determined by the current state of the system. It does not mean that chaotic systems are totally predictable. As will be explained in the next section, one of

the fascinating and unique features of chaotic systems is that they are deterministic without being totally predictable. This point is worth emphasizing because we will show later in this paper that warfare is chaotic. We will also discuss how this insight can help us understand warfare and improve our ability to wage war. We do not, however, claim that we can reduce war to a mechanistic set of equations.

## 2. CONCEPTS AND TERMINOLOGY IN CHAOS THEORY

In this section, several key concepts in chaos theory will be reviewed. These include nonlinearity, phase space, attractors, strange attractors, and fractals.

Nonlinearity: If a system is linear, it means that the output of the system is linearly related to the input. In other words, if the input is doubled then the output will be doubled. If the input is tripled then the output will be tripled and so on. Nonlinear systems do not behave like this and are often very sensitive to input. A folklore example of a nonlinear system is the straw that broke the camel's back. Each additional weight added to the camel's back makes very little difference until its maximum capacity is reached. At that point, even the smallest addition of weight has a dramatic, and nonlinear, effect on the camel. The reason that chaotic systems are so sensitive to initial conditions is that the laws that govern chaotic systems are described by nonlinear equations.

Phase space: The construction of a phase space plot is often used to better understand chaotic behavior. A phase space plot is just a plot of the parameters that describe system behavior. It is useful because it provides a pictorial perspective for examining the system.

An example of a phase space plot for a simple pendulum is shown in Figure 1.

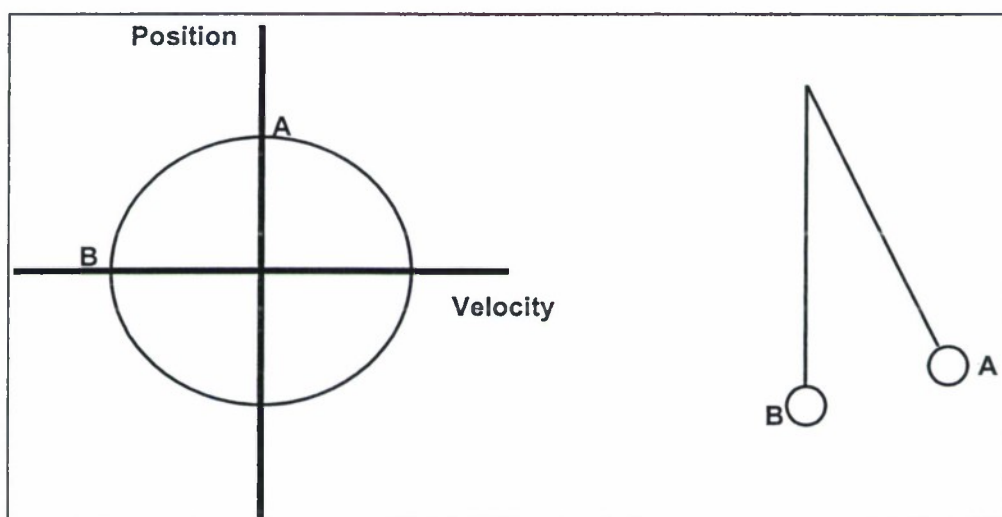

Figure 1.

Illustration of phase space for a pendulum

At **A** the pendulum is the maximum positive distance from the bob's neutral point but its velocity is zero. This is shown as point **A** on the phase space diagram. Likewise, at **B** the distance of the bob from its neutral position is zero but its velocity is at a maximum (in a negative sense). The other points of the phase space plot just show the relation between the velocity and position for other pendulum positions. In this case, where there is no friction, the motion of the

pendulum is constrained to remain on the elliptical path shown in the phase space plot. The technical term for this ellipse is the attractor for the system. One can see that this attractor is periodic because, the path of the system exactly repeats itself in each orbit around the origin.

In contrast, Figure 2 shows an attractor for a chaotic system.

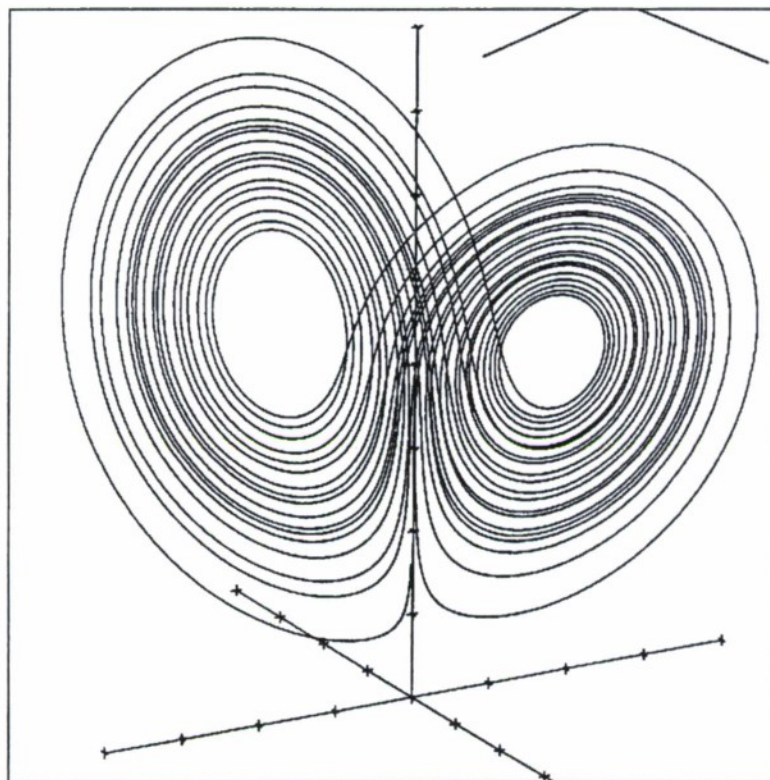

Figure 2. The Lorenz attractor<sup>6</sup>

The complexity of this attractor has led to its being dubbed a strange attractor. Although there are still constraints as to how the system behaves, there are a lot more possible states for the system. It is important to note that the phase space

paths of a chaotic system will never coincide. If this were to happen, then the system would become periodic. The longer a chaotic system is observed the more paths are taken and the messier the phase space plot of the attractor appears.

Superficially, the attractor may appear to be completely disorganized. Closer examination of the phase space, however, reveals that the attractor is extremely organized but in an unconventional manner. This will be discussed later in the section on fractals.

A second important feature illustrated in Figure 2 is that the phase space has two interconnected lobes. Each lobe represents significantly different behaviors of the same system. The interconnections indicate that the system can go from one behavior to another. When an attractor consists of multiple lobes, it is called a multiple attractor.

The Earth's climate may be a good example of this sort of behavior. Our current climate appears to be relatively stable and might be depicted as lying within one of the lobes. This allows some variation in the climate but constrains its general behavior to some norm. On the other hand, we know that the Earth's climate was significantly different during the ice ages than it is today. The Earth's climate during an ice age would lie in another lobe of the attractor. The sensitivity of chaotic systems is further illustrated by the fact that a catastrophic change in system behavior (moving from one lobe to another) could be caused by a small change in initial conditions.

Fractals: We generally define things dimensionally in terms of integers. Lines are one dimensional, planes are two dimensional, and solids are three dimensional. At first sight it appears to be nonsense to talk about things with a fractional dimension of, for example, 1.5. Such an object would be more than a line but somehow less than a plane. Nevertheless, such things are not only thought to exist, but such geometries are central to chaos theory. One example of such a geometry is the Koch snowflake.

The Koch snowflake starts as an equilateral triangle. A one-third scale equilateral triangle is added to each side. A one-third scale triangle (of the new, smaller triangle) is then added to each side of the resulting figure. This process is continued ad infinitum as illustrated in Figure 3.

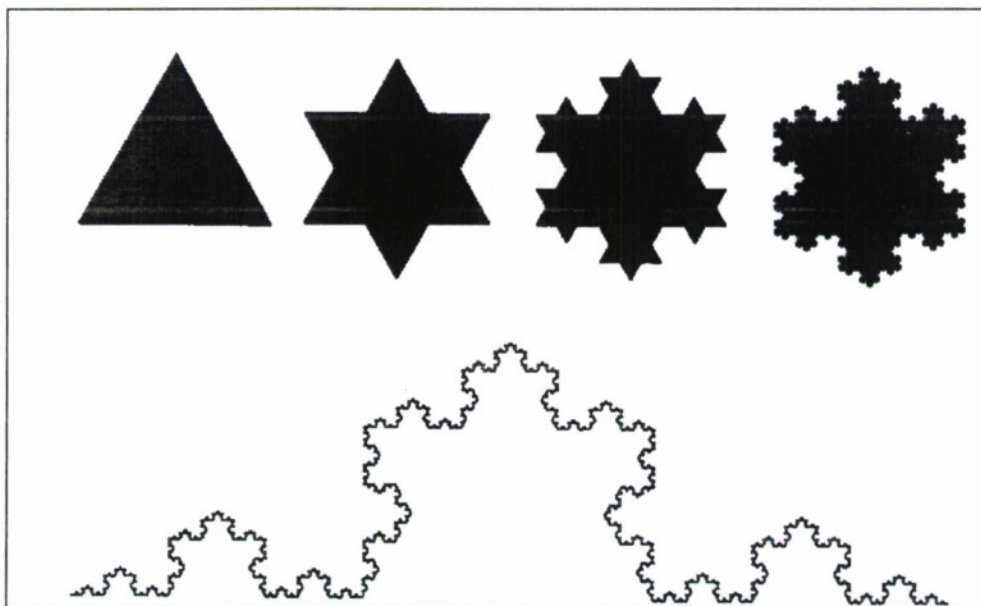

Figure 3. The Koch snowflake<sup>7</sup>

The perimeter of this shape has several unique features. First, although it is a single, continuous loop that does not intersect itself and circumscribes a finite area, its length is infinite. Second, Mandelbrot calculated that the dimension of the perimeter of the Koch snowflake is 1.26.<sup>8</sup> This means that the perimeter is between a line and a plane. Third, the shape of the perimeter of a Koch snowflake is self-scaling. That is, the perimeter would look the same whether you looked at it with the naked eye or with a powerful microscope. These geometries are pertinent to chaos because strange attractors are fractal. Strange attractors, like the Koch snowflake, are infinite curves that never intersect within a finite area or volume. This observation implies that chaotic systems are insensitive to scale.

### 3. POPULATION LEVELS AS AN EXAMPLE OF A CHAOTIC SYSTEM

A Malthusian model for population growth says that next year's population (at  $t=n+1$ ) will be related to this year's population (at  $t=n$ ) by a linear factor. As an equation, this would look something like

$$\begin{aligned} x_{n+1} &= rx_n \\ 0 &\leq x_n < 1 \end{aligned} \tag{1}$$

where  $r$  represents the birth rate and  $x_n$  the normalized population. This is an unrealistic expectation as population will eventually cease to rise as rapidly -- either when predator populations also rise or when food becomes scarce. Robert May examined a more realistic model for population

level, but one that contained far more complexity than he had anticipated.<sup>9</sup>

The equation that he worked with was

$$x_{n+1} = rx_n(1-x_n) = rx_n - rx_n^2 \quad (2)$$

where the additional term,  $rx_n^2$ , represents the death rate due to predators. This is a nonlinear difference equation which he used to calculate successive values of  $x_n$ , starting from some arbitrary value. He found that the behavior of the equation depended heavily on the value of  $r$ . He found that when  $r$  was small the population quickly reached an equilibrium level. This represents a static ecological balance between birth and death rates, and is illustrated for  $r$  in region A in Figure 4.

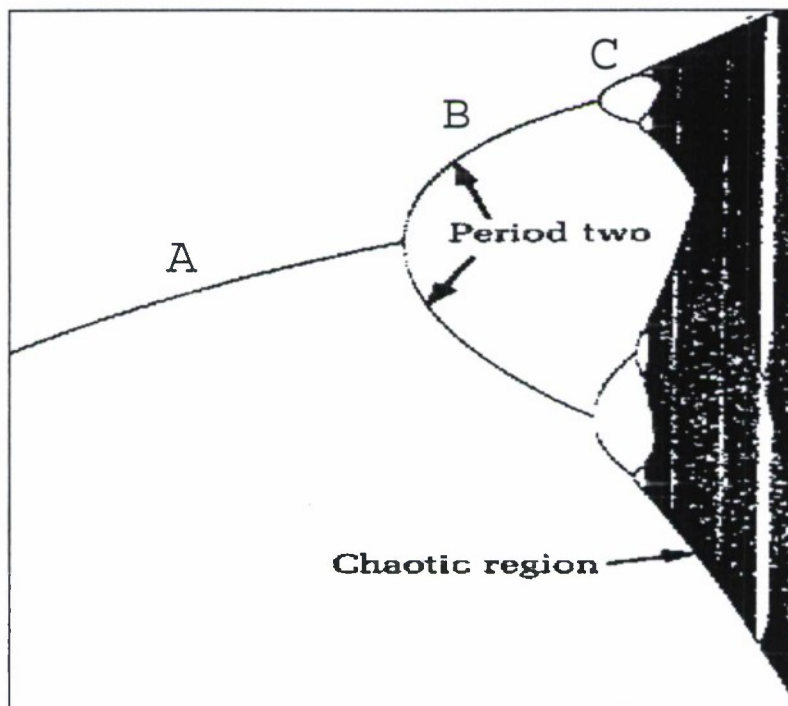

Figure 4.  
Variation of population level.<sup>10</sup>  
X-axis is in increasing values of  $r$ .  
Y-axis is in increasing population levels.

When the value of  $r$  was increased, he found that the population became periodic and varied between two numbers in alternate years. This modeled an interaction between the predator population and the species population where many predators one year would reduce the population of the species. But, when the species died off, the predators died off as well due to lack of food. Next year, with fewer predators, the species' population would rise again. Referring to Figure 4, this would be the case for  $r$  in region B. As  $r$  increased, he found that the number of years for a cycle (and the number of values that the population could have) doubled, and doubled again. This is illustrated by the doubling of the lines for  $r$  in region C in Figure 4. When  $r$  was increased beyond a critical value, the variation in population ceased to be periodic at all.

Instead, population varied wildly and apparently randomly from year to year. This is shown by the dark areas in Figure 4. Although the behavior now appeared to be random, Figure 4 shows that there is a structure to the behavior. Out of the apparently random behavior, periodic regions appear again suddenly. These are the white regions in Figure 4. As  $r$  increased, these would once again become the apparently random dark areas. In addition to complex internal structure, the behavior is bounded. Interestingly, as Figure 5 shows, when portions of the apparently random regions are magnified, they display a structure similar, but not identical, to the overall

structure. The fractal nature of this plot confirms that the apparently random behavior is not random at all but chaotic.

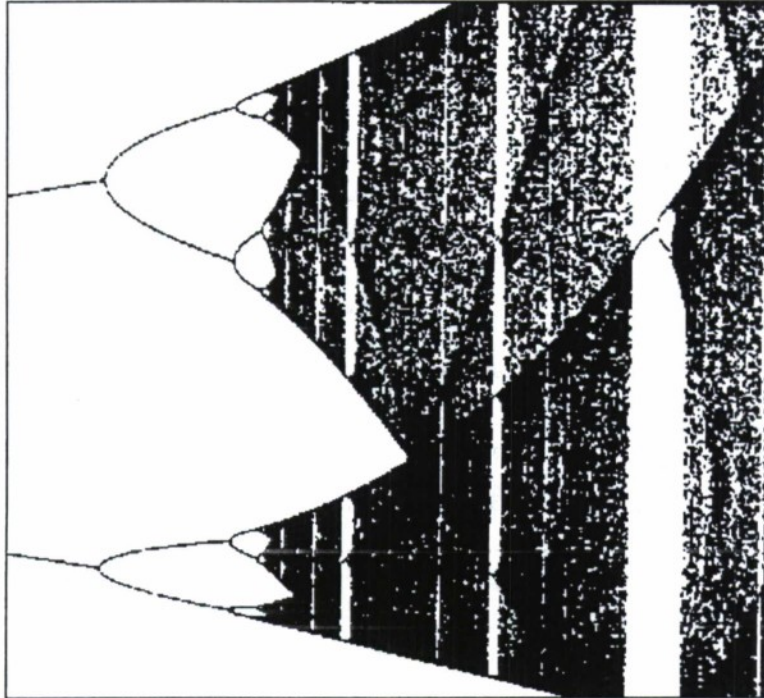

Figure 5.  
Representative magnified view of  
region C from Figure 4<sup>11</sup>

#### 4. APPLICATIONS OF CHAOS THEORY

Chaos theory has been applied in many areas. Some of these, such as weather and population levels, have already been mentioned. In introducing additional examples, it is not the intent of this section to exhaustively review the research. Instead, we hope to indicate the types of research that have been done and to provide the reader with some idea as to how chaos is relevant.

In science and engineering, chaos theory has been applied to better understand several different phenomena. In the area of fluid flow, for example, chaos is thought to explain phenomena ranging from turbulence, to the length of time between drops falling from a leaking faucet, to the Red Spot on Jupiter, to the curls generated by a burning cigarette.<sup>12</sup> A better understanding of turbulence would be particularly important as turbulent flows can be highly destructive. Chaos theory has also been successfully applied to problems in structural dynamics such as flutter in helicopter rotor blades and structural buckling.<sup>13</sup> A particularly promising line of research has suggested that the nonlinearity of chaotic systems can be used to improve the efficiency with which chaotic systems are controlled.<sup>14</sup> It also appears that natural shapes, such as coastlines and the shapes of plants, are often fractal. Such geometries are closely tied to chaos theory.<sup>15</sup> Finally, chaos theory has been used to describe the motion of various mechanical systems such as driven pendulums.

The main reason why chaos theory has many applications in science and engineering is that the linear models that have been developed to describe fluid and structural motions are generally constrained to small amplitude motion. If the motion amplitudes or the velocities increase, then higher order terms become more important and the approximating equations needed to describe the motion become nonlinear. This transformation from a well-behaved linear system to a difficult nonlinear system is very common.

Chaos theory has also been applied to the social sciences. In particular, there has been considerable interest in whether social phenomena, previously thought to be random, have an underlying chaotic order. Several mathematical tests for chaotic behavior have been applied to historical data from both the stock market and cotton prices. Although there is some controversy, stock market levels and cotton prices have been found to display fractional dimensions (a strong indicator of the presence of chaos). In addition, cotton prices have shown a tendency to scale regardless of the length of the time examined. Such findings indicate that these economic phenomena have a deterministic basis as opposed to being random. Naturally, this has gotten some business attention and at least two firms are now using chaos theory to guide their financial advice.<sup>16,17</sup>

Preliminary results also indicate that strategic decision making may be chaotic. In one study, participant responses in a game called "the prisoner's dilemma" were recorded. In this game, two players are "arrested" and are presented with a choice. If one prisoner confesses and the other does not, the confessing prisoner will go free. If both prisoners confess, they will both be punished. If they both are silent, then they may both be punished. When this game is repeated again and again, the pattern of the participants' responses has been found to be chaotic.<sup>18</sup>

Strategic decision making in response to another's actions is, of course an integral part of war. So, the possibility

that strategic decision making exhibits chaotic behavior strongly suggests that warfare may also be chaotic. In support of this position, Beyerchen has convincingly argued that war is nonlinear.<sup>19</sup> He pointed out that Clausewitzian friction, where small events can have large consequences, is inherently nonlinear. In addition, the very nature of the interaction between opponents who are not necessarily playing by the same rules is nonlinear. So far, however, the only quantitative evidence for the presence of chaos in warfare has been limited to studies of computer simulations. Both computer wargames<sup>20</sup> and arms race simulations<sup>21</sup> have been found to exhibit nonperiodic and nonmonotonic behavior.

#### **B. GOALS OF RESEARCH**

As just discussed, there are grounds for thinking that warfare might be chaotic. What has not been done is to apply quantitative tests for chaotic behavior to data generated by warfare. This procedure is a direct analogy to examining the history of stock market prices to see if there is chaos in the stock market. Such warfare research has the following benefits. First, it treats warfare as an entire system as opposed to a piece of it like strategic decision making. Second, it is based upon real-life data, unlike the models in wargames. We can therefore be assured that the behavior observed is not just an artifact of our particular model. Third, it is quantitative in nature, and therefore less subject

to interpretation. Our first research goal, then, was to apply several of the available quantitative tests to determine if time series data related to war is chaotic. If successful, this would be the first firm evidence that warfare is actually chaotic.

Our second research goal was to explore the implications of chaos theory for warfare. Other researchers have looked for chaotic characteristics in warfare to show that warfare is chaotic. If we have first quantitatively proven that warfare is chaotic, we can reverse the logic and say that warfare and wargames must display the characteristics of a chaotic system. Our second research goal, then, is to translate the characteristics of a chaotic system into the context of warfare. In this way we will explore how chaos theory can be used to better understand warfare in general and the operational level of warfare in particular.

## II. TESTS FOR IDENTIFICATION OF CHAOTIC BEHAVIOR IN EXPERIMENTAL AND HISTORICAL DATA

### A. INTRODUCTION

In this chapter, we examine several methods and algorithms for determining the presence of chaos in data associated with warfare. The experimental data (output data from wargames) and the available historical data are in the form of time series for different variables. Since the relationship is usually unknown, we concentrate our attention on methods for identification of chaotic behavior in a time series

$$\xi(t_0), \xi(t_1), \dots, \xi(t_N) \quad (3)$$

where for experimental or historical data the time intervals  $\Delta t_i$

$$t_{i+1} = t_i + \Delta t_i \quad (4)$$

are usually equal

$$\Delta t_1 = \Delta t_2 = \dots = \Delta t_{N-1} = \tau \quad (5)$$

In the next section, we will present four possible criteria for distinguishing chaotic behavior. In all four criteria, chaos is indicated by a qualitative change. After that, we will introduce quantitative measures to characterize deterministic chaos. Finally, we will discuss some problems in identification of chaotic behavior in short and noisy time series, error estimation, and data requirements for specific algorithms.

## B. QUALITATIVE CRITERIA FOR CHAOTIC BEHAVIOR

### 1. TIME DEPENDENCE

Chaos can be qualitatively determined by examining the general appearance of the time series data. An example of a time series generated by the Henon map<sup>22</sup>

$$\begin{aligned} x_{i+1} &= 1 + y_i - ax_i^2 \\ y_{i+1} &= bx_i \end{aligned} \quad (6)$$

is presented in Figure 6.

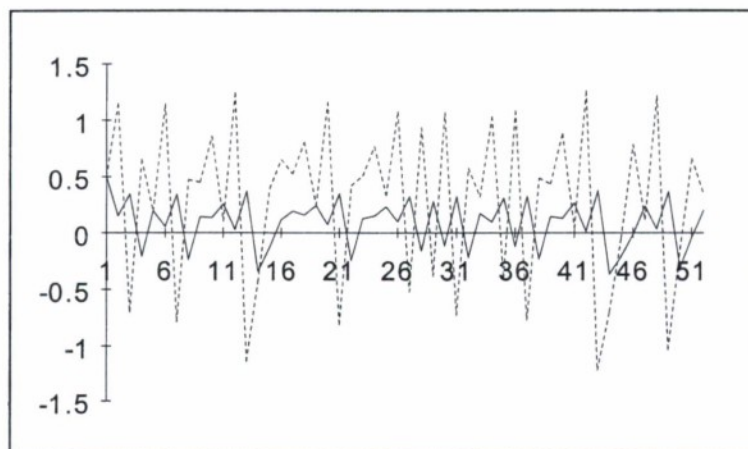

Figure 6.  
Time series generated by the Henon map.<sup>23</sup> Both  $x$  (dotted line) and  $y$  (solid line) are plotted.

This is a known chaotic trajectory. It has a ragged appearance, which persists for as long as time iterations are carried out. Although its recurrent nature is evident by the fact that certain patterns in the waveform repeat themselves at irregular intervals, there is never exact repetition, and the motion is truly nonperiodic. Furthermore, the variables stay in a limited region of values. Finally, when two identical

chaotic systems are started in nearly identical conditions, the two motions diverge from each other at an exponential rate. In Figure 7 we present the divergence from two adjacent starts for the logistics equation.<sup>24</sup>

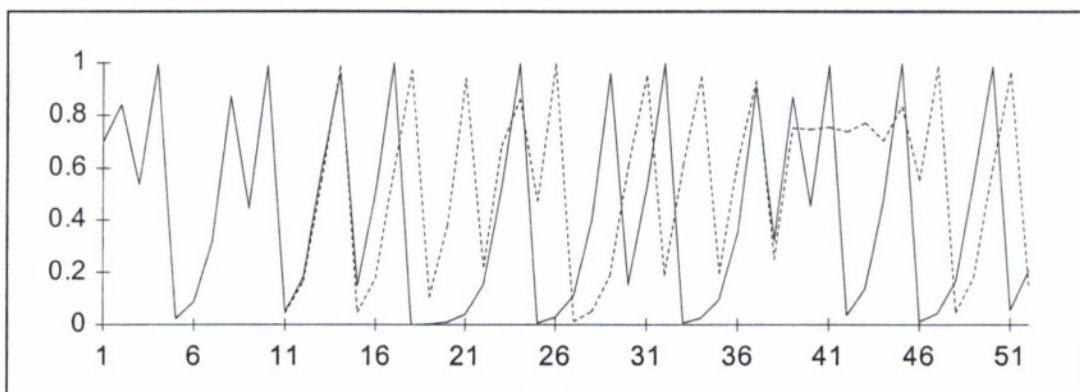

Figure 7.  
Divergence from nearly identical initial conditions for the logistics equation<sup>25</sup>

Of course, if the starting conditions were exactly the same, then the deterministic nature of the equation guarantees that the trajectories are identical. But since some uncertainty in the starting condition is inevitable with real systems, the divergence of nominally identical motions cannot be avoided in the chaotic regime.

## 2. AUTOCORRELATION FUNCTION

Though the two adjacent starts appear to remain close to each other for a time, after some period they rapidly become uncorrelated. On the average, their separation increases by a fixed multiple for any given interval of elapsed time. Because of the exponential divergence, it is impossible to impose long

term correlation of the two trajectories by reducing the initial perturbation, since each order of magnitude improvement in initial agreement is eradicated in a fixed increment of time.<sup>26</sup> A measure of the correlation between the trajectories is the autocorrelation function  $C(\gamma)$  of a time series, which for continuous signals is defined by

$$C(\gamma) = \lim_{T \rightarrow \infty} \frac{1}{T} \int_0^T \xi(t) \xi(t + \gamma) dt \quad (7)$$

where

$$c(t) = \xi(t) - \lim_{T \rightarrow \infty} \frac{1}{T} \int_0^T \xi(\sigma) d\sigma \quad (8)$$

and for discrete systems (in the analysis of time series)

$$C(\gamma) = \lim_{N \rightarrow \infty} \frac{1}{N} \sum_{i=1}^N c(t_i) c(t_i + \gamma) \quad (9)$$

$$c(t_i) = \xi(t_i) - \lim_{N \rightarrow \infty} \frac{1}{N} \sum_{j=1}^N \xi(t_j)$$

where  $\gamma$  is multiple to  $\tau$ .<sup>27</sup>

A rapid decay, mostly with an exponential tail, of the autocorrelation function is a criterion for presence of chaos.<sup>28</sup>

### 3. POWER SPECTRUM

Another qualitative criterion for chaos is the frequency distribution of the time series. The power spectrum  $P(\omega)$  is proportional to the Fourier transformation of the autocorrelation function and is defined by the equation

$$P(\omega) = |c(\omega)|^2 = \lim_{T \rightarrow \infty} \int_0^T C(\gamma) d\gamma \quad (10)$$

for continuous systems. The presence of broadband noise in the power spectrum is typical for chaotic regimes.<sup>29</sup>

#### 4. POINCARÉ MAPS

Often systems need three or more variables to describe system behavior. In these cases, three or more dimensions are required to plot the system's trajectory in phase space. In periodic systems, constructing and understanding three-dimensional plots is straightforward.

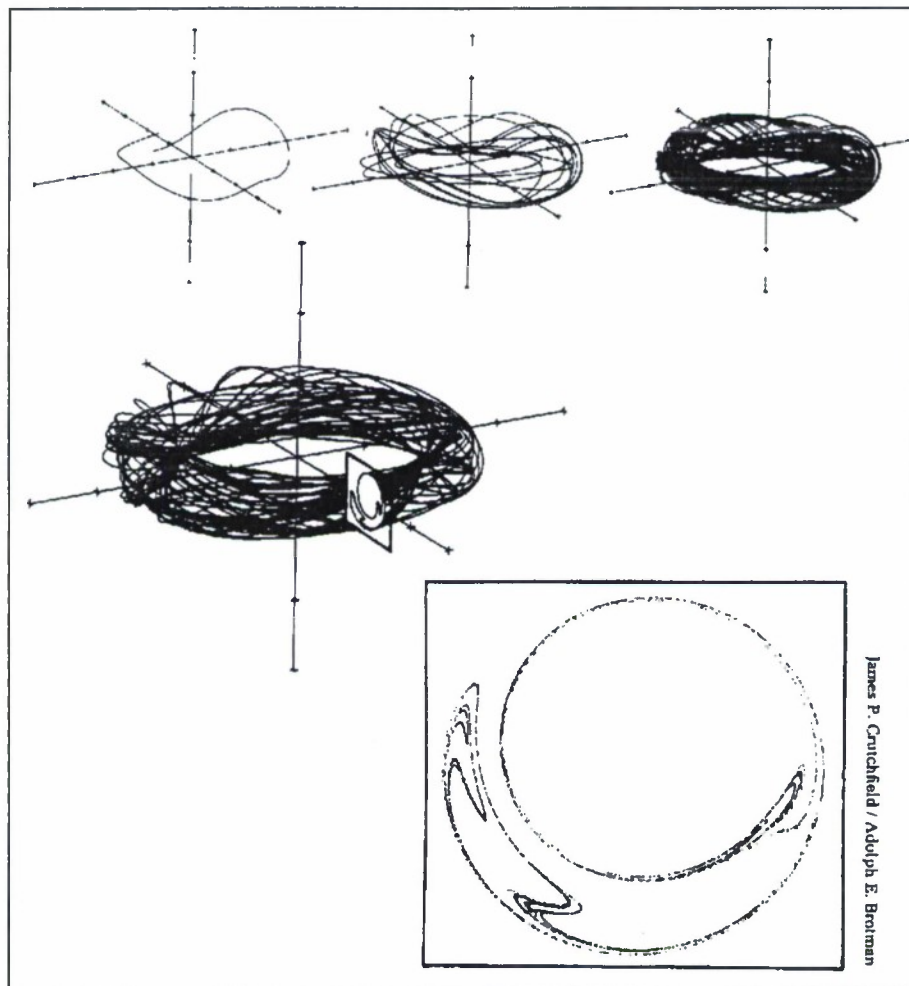

Figure 8. Poincaré map<sup>30</sup>

In chaotic systems, however, the strange attractor is often a tangled mess of never quite touching trajectories, as illustrated in Figure 8.

It is possible to simplify the portrayal of the attractor by taking a two-dimensional slice through it (shown in the lower half of Figure 8). This also makes the structure of the attractor more obvious. This two-dimensional section is called a Poincare map. Poincare maps can be used to determine if a system is chaotic by visually depicting the nature of the attractor. If a system is chaotic, it will have a strange attractor and the Poincare map will show fractal characteristics. That is, the Poincare map will be self-similar regardless of scale.<sup>31</sup>

In this research, we were dealing with time series data where the value of one parameter (such as casualties) was tracked versus time. To construct a higher order phase space from this data, we use Takens' method of "embedding time."<sup>32</sup> This method involves displacing the time value so that the value of a parameter now is compared to the value of that parameter at a previous time. Consider the following example.

Series 1:	1	3	-1	0	2	1.5	.	.	.
Series 2:	-	1	3	-1	0	2	1.5	.	.
Series 3:	-	-	1	3	-1	0	2	1.5	.

Figure 9.  
Phase-space trajectories of chaotic systems

In this example Series 1 represents our original time series of data. Series 2 is the same set of data displaced by one sample, and Series 3 is the same set displaced by two samples. The amount of the displacement is called the embedding time. In Series 2 the embedding time is one, and in Series 3 it is two. This method has been successfully used in a wide variety of systems that are characterized by time series data. This may appear to be an artificial way of generating additional data. However, it really reflects the possibility that a current value of the system can depend on, and should therefore be related to, previous values of the system. In fact, an implicit aspect of chaos theory is that the current state of the system depends very much on all previous system history.

In our work, we used software from the Naval Postgraduate School in Monterey, California, to produce Poincare maps. We examined these maps for fractal characteristics.

In summary, we presented four possible criteria for chaotic behavior:

- a. The time dependence of the parameter "looks chaotic"
- b. The autocorrelation function decays rapidly
- c. The power spectrum exhibits broadband noise
- d. The Poincare map shows space-filling points

With all four criteria, chaos is indicated by a qualitative change, and it is not always possible to conclude that chaos is present.<sup>33</sup> In the next section we introduce quantitative measures to characterize deterministic chaos.

## C. QUANTITATIVE CRITERIA FOR IDENTIFICATION OF CHAOTIC BEHAVIOR

### 1. LYAPUNOV EXPONENTS

One of the quantitative tests for chaotic behavior is to compute the Lyapunov exponents of the system. An  $n$ -dimensional system has  $n$  one-dimensional Lyapunov exponents. These measure the exponential attraction or separation, over long periods of time, of two adjacent trajectories in phase space with different initial conditions. Positive Lyapunov exponents indicate chaotic behavior. For a system whose equations of motion are known, the definition of the largest Lyapunov exponent is: starting from a point  $x(0)$  within the phase space basin of an attractor, and initial perturbation  $\delta x(0)$  in the tangent space of  $x(0)$ , find  $x(t)$  from the equations of motion and  $\delta x(t)$  from the linearized equations of motion. The largest Lyapunov exponent is then defined by

$$\lambda_1 = \lim_{t \rightarrow \infty} \frac{1}{t} \log_2 \frac{\|\delta x(t)\|}{\|\delta x(0)\|} \quad (11)$$

if the limit exists.

Wolf et al<sup>34</sup> have described an algorithm to extract the largest one or two Lyapunov exponents from time series data. Another method, proposed by Eckmann and Ruelle,<sup>35</sup> in principle permits the estimation of all positive Lyapunov exponents. According to Vestano and Kostelich,<sup>36</sup> however, only the Wolf algorithm is suitable for the analysis of experimental data. In describing Wolf's algorithm we will follow Mayer-Kress.<sup>37</sup>

The first step towards computing Lyapunov exponents is to construct the attractor from the experimental data. With the now classical time-embedding technique from the time series Eqn. 3 we construct a set of points of the form

$$x_i = \{\xi(t_i), \xi(t_i + \tau), \dots, \xi(t_i + \{m-1\} \tau)\} \quad (12)$$

One assumes that the behavior of the experiment, or the historical data, can be described by a finite dimensional attractor whose dynamical properties can be recovered by this method of time delay reconstruction if the embedding dimension  $m$  is large enough.

For a stable linear system all Lyapunov exponents are negative. If the largest Lyapunov exponent,  $\lambda_1$ , is greater than zero, then the attractor is chaotic, and very small changes in initial conditions grow exponentially, at least for a short time.

Figure 10 is a schematic illustration of the Wolf procedure to calculate  $\lambda_1$ .

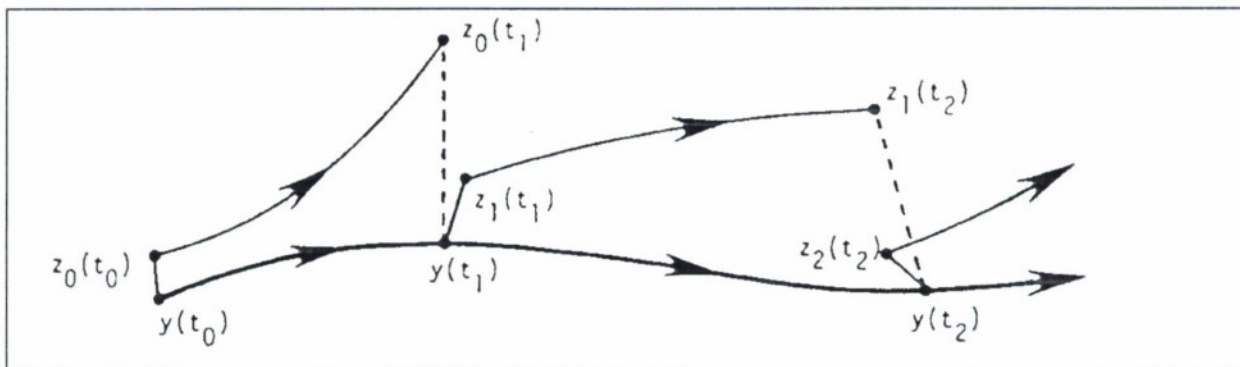

Figure 10.  
Schematic representation of the Wolf  
algorithm to compute  $\lambda_1$ <sup>38</sup>

Begin with the first data point  $y(t_0)$  and its nearest neighbor  $z_0(t_0)$ , which are a distance  $L_0$  apart. The two points are incremented by time steps  $\Delta t$  until the distance  $L'_0$  between them exceeds some value  $\varepsilon$ . The first incremental data point  $y(t_1)$  is retained, and a new neighbor  $z_1(t_1)$  is sought such that the Euclidean distance

$$L_1 = \|y(t_1) - z_1(t_1)\| \quad (13)$$

is again less than  $\varepsilon$ , and such that  $z_1(t_1)$  lies as nearly as possible in the same direction from  $y(t_1)$  as  $z_0(t_1)$ .

The procedure continues until the fiducial trajectory  $y$  has been followed to the end of the time series.<sup>39</sup> The largest Lyapunov exponent of the attractor is estimated as

$$\lambda_1 = \frac{1}{N\Delta t} \sum_{i=0}^{M-1} \log_2 \frac{L'_i}{L_i} \quad (14)$$

where  $M$  is the number of replacements and  $N$  is the total number of time steps that the fiducial trajectory  $y$  has been followed. Further discussion of the procedure for choosing the replacement point and the implementation of the algorithm can be found in Mayer-Kress.<sup>40</sup>

In this way a reasonably accurate estimate of the largest Lyapunov exponent may confirm the presence of chaos and quantify it. But an attractor, defined by a finite data set, requires at least two nearby phase space trajectories. When the system's equations are known, or we can perform experiments from close enough starting points, the orbital divergence rate

provides a useful characterization of the data. This may not be the case, however, with historical data. If not, it is more useful to use the method for defining the correlation dimension of the attractor.

## 2. CORRELATION DIMENSION

Because a chaotic system derives from a system with a few degrees of freedom, and because its behavior remains within spatial boundaries, one can identify a chaotic system by its low fractal dimension and by its regularity in spatial bounds. In a chaotic system, the positions of two points along the same trajectory are uncorrelated by definition due to the sensitivity to initial conditions. Yet since all points together are influenced by the boundary region of the chaotic system, there is a spatial correlation that can be described. The so called correlation coefficient is defined as

$$C(r) = \lim_{N \rightarrow \infty} \frac{1}{N^2} \sum_{i,j=1}^N H(r - \|x_i - x_j\|)$$

(15)

where  $\|\cdot\|$  denotes a Euclidean distance, and the step function  $H(x)$  is defined by  $H(x)=1$  for positive  $x$ ,  $H(x)=0$  otherwise.<sup>41</sup> A hypersphere of radius  $r$  is centered at each point to examine the number of points within the sphere and its dependence on  $r$ . Thus  $C(r)$  compares the distance between each  $i$  and  $j$  points, counts those falling within the hypersphere of radius  $r$ , and then normalizes the total with a  $\frac{1}{N^2}$  factor.

For each value of the embedding dimension  $p$ , one calculates  $C(r)$  for a wide range of radius values. Since the values of  $C(r)$  are proportional to  $r^\nu$ , with  $\nu$  approximating the dimension of the attractor, one can obtain estimates of  $\nu$  by estimating the slope of the  $\log C(r)$  versus  $\log(r)$  function in the region of  $r$  where the plot shows a straight line. One then plots the estimated slopes against the embedding dimension  $p$ . In the case of random series, the slopes continue to increase linearly with  $p$ . If the slopes become independent of  $p$  (i.e., saturate rather than increase linearly), then the chaos is deterministic with

$$\lim_{p \rightarrow \infty} \nu$$

(16)

approximating the dimension of the system.

### 3. KOLMOGOROV-SINAI ENTROPY

The Kolmogorov entropy, often called Kolmogorov-Sinai (KS) entropy, is the most important measure by which chaotic motion in phase space can be characterized.<sup>42</sup> To calculate it, consider the trajectory  $x(t)$  of a dynamical system on a strange attractor and suppose that the  $d$ -dimensional phase space is partitioned into boxes of size  $l^d$ .<sup>43</sup> The state of the system is now measured at intervals of time  $\tau$ . Let  $P_{i_0 \dots i_n}$  be the joint probability that  $x(t=0)$  is in box  $i_0$ , that  $x(t=\tau)$  is in box  $i_1$ , and  $x(t=n\tau)$  is in box  $i_n$ . According to Shannon, the quantity

$$K_n = - \sum_{i_0 \dots i_n} P_{i_0 \dots i_n} \log P_{i_0 \dots i_n}$$

(17)

is proportional to the information needed to locate the system on a special trajectory  $i_0^* \dots i_n^*$  with precision  $l$  (if one knows a priori only the probabilities  $P_{i_0^* \dots i_n^*}$ ).<sup>44</sup> Therefore,  $K_{n+1} - K_n$  is the additional information needed to predict in which cell  $i_{n+1}^*$  the system will be if we know that it was previously in  $i_0^* \dots i_n^*$ . This means, that  $K_{n+1} - K_n$  measures our loss of information about the system from time  $n$  to time  $n+1$ .

The KS-entropy is defined as the average rate of loss of information:

$$\begin{aligned} K &= \lim_{\tau \rightarrow 0} \lim_{l \rightarrow 0} \lim_{N \rightarrow \infty} \frac{1}{N\tau} \sum_{n=0}^{N-1} (K_{n+1} - K_n) \\ &= - \lim_{\tau \rightarrow 0} \lim_{l \rightarrow 0} \lim_{N \rightarrow \infty} \frac{1}{N\tau} \sum_{i_0^* \dots i_{N-1}^*} P_{i_0^* \dots i_{N-1}^*} \log P_{i_0^* \dots i_{N-1}^*} \end{aligned} \quad (18)$$

The limit  $l \rightarrow 0$  (which has to be taken after  $N \rightarrow \infty$ ) makes  $K$  independent of the particular partition. For maps with discrete time steps  $\tau=1$ , the limit  $\tau \rightarrow 0$  is omitted.

For details on the theoretical foundation of this approach refer to Wu.<sup>45</sup> A technique for deriving the metric entropy of strange attractors from scalar time series is presented by Fraser.<sup>46</sup>

#### 4. RELATION BETWEEN THE METHODS FOR QUANTITATIVE DESCRIPTION OF CHAOS

The fractal dimension (Hausdorff dimension), information dimension, and correlation dimension are usually different, but close in value. In fact, they are three of an infinite number of different (and relevant) generalized dimensions that

characterize an attractor. This hierarchy of generalized dimensions  $D_q$  can be expressed as <sup>47</sup>

$$D_q = \lim_{r \rightarrow 0} \frac{\ln \sum_i p_i^q}{\ln r} \quad (19)$$

where  $p_i^q$  is the probability that a trajectory point falls into the  $i$ -th  $k$ -dimensional box (subspace) of size  $r$  in a  $k$ -dimensional phase space. It is shown by Hentschel and Procaccia that  $D_0$  corresponds to the Hausdorff dimension,  $D_1$  to the information dimension, and  $D_2$  to the correlation dimension.<sup>48</sup>

This fact can be used to increase the reliability of our estimations. For example, when the Lyapunov exponent spectrum can be obtained, the Lyapunov dimension  $D_L$  is given by the Kaplan-Yorke conjecture which is valid for typical attractors<sup>49</sup>

$$D_L = l + \frac{\sum_{j=1}^l \lambda_j}{|\lambda_{l+1}|} \quad (20)$$

where

$$\sum_{j=1}^l \lambda_j \geq 0 \geq \sum_{j=1}^{l+1} \lambda_j \quad (21)$$

and is usually close to the correlation dimension in value. Further details on the relationship between the correlation dimension and the KS entropy can be found in Zeng.<sup>50</sup>

## 5. ERROR ESTIMATION AND DATA REQUIREMENTS

The accuracy with which the characteristics of a chaotic system are defined depends on the amount and the accuracy of the input data, the reliability of the method and the respective algorithm. For error estimation, intrinsic<sup>51</sup> or traditional<sup>52</sup> statistical methods are used. Especially challenging is the processing of noisy data. For estimation of Lyapunov exponents from noisy data the algorithms in Brown<sup>53</sup> and Damming<sup>54</sup> can be used. The correlation dimension in such cases can be estimated using the algorithms developed by Green<sup>55</sup> and Fraedrich.<sup>56</sup>

In the attempt to define the characteristics of a chaotic system from historical data we were limited by the available amounts. Richards<sup>57</sup> suggests that a reasonable estimate of the correlation dimension is usually obtained at about 100 points. This suggestion is somewhat optimistic, because the number of data points required for reliable estimation of the correlation dimension depends on the yet unknown dimension of the chaotic system. According to Ruelle,<sup>58</sup> at least

$$M = 10^{v/2}$$

(22)

are necessary to reliably estimate fractal dimension  $v$ . This is the least strict of several different criteria.

For the estimation of the Lyapunov exponent Zeng<sup>59</sup> discards the first 10,000 data points from experimentally generated time series to eliminate the transients, and processes the next

5,000 observations. Sarigul-Klijn<sup>60</sup> estimates the largest Lyapunov exponent from 6,000 data points. Developing algorithms for estimation of the Lyapunov exponents from "short" time series, the authors usually work with about 2,000 data points.<sup>61</sup> Further details on the error estimation techniques and the data requirements of the quantitative tests for chaotic behavior can be found in Mayer-Kress.<sup>62</sup>

### III. WARFARE DATA

#### A. INTRODUCTION

In this chapter, we describe data characteristics required for analysis of chaotic behavior. After that, we present some potential sources for warfare data, including historical and wargame data at four levels of war. Finally, we introduce the data actually used in our analysis of determination of chaotic behavior in warfare.

#### B. DATA CHARACTERISTICS

The data for analysis of chaotic behavior has to have certain characteristics. First, the data should be relevant to the area where we are looking for chaos. For instance, if this area is warfare at the strategic or operational level, losses of aircraft, main battle tanks, artillery pieces or numbers of targets damaged or destroyed during armed conflicts could be considered suitable data for chaotic analysis. On the other hand, if we are trying to determine the presence of chaotic behavior in the grand strategic decision making process, we probably need data from the military budget, or defense investments, or the like. Second, to be suitable for mathematical algorithms developed for determination of chaos, the data has to be quantitative and in a time series without gaps. Third, the data has to provide a large sample size, depending on the method used to determine chaos described in Chapter II. It should be noted that the larger the sample size of the data, the higher probability that the results of

analysis for determining chaos reflect reality. Because wars generally don't last more than a few years, daily or weekly data are necessary to provide sufficient sample size for the analysis; monthly data records provide an insufficient number of time increments. Fourth, the data has to measure some output of warfare, as opposed to input. For example, authorized strength of a combat unit would be an input; casualties suffered by that unit would be an output. Fifth, the data has to reflect interaction with the enemy or potential enemy. Sixth, data that is an aggregate measure of some aspects of warfare is preferred. This is analogous to chaotic weather patterns (output) that are the result of innumerable input variables such as temperature, winds, and atmospheric pressure. For example, data on aircraft losses during the whole period of conflict are related to many factors such as number of sorties, the effectiveness of an enemy air defense and its supply system, flying skills of pilots, aircraft vulnerability, and so forth. Seventh, the data preferably should be reliable, that is, free of unknowns and subjective judgments.

### **C. POTENTIAL DATA SOURCES**

#### **1. HISTORICAL DATA**

Historical records can provide a rich source of data for chaos research. Statistics from the grand strategic, strategic, operational, and tactical levels of war all lend

themselves to analysis for chaotic behavior. The US Air Force Historical Research Agency (HRA), and the Air University Library, located at Maxwell Air Force Base, Alabama, have a vast collection of documents regarding USAF combat experiences. No doubt the history offices and libraries of other services also have very rich and available sources of data which could be used for determination of chaotic behavior in warfare.

#### (A) GRAND STRATEGIC LEVEL OF WAR

At the grand strategic level of warfare, potential historical data sets could include defense investment data from 1948 through 1993,<sup>63</sup> and US government budgetary data from 1940 through 1992.<sup>64</sup> These data aggregate such factors as technology push, material obsolescence, the overall condition of the economy at key stages in the business cycle, and long term changes in the structure of the economy. At the same time, defense investment reflects decision making at the grand strategic level under bureaucratic and political conditions. Taking all these factors into consideration, it is apparent that chaotic behavior associated with the grand strategic level of war could be in these data. Arms sales could be another potential source of data for chaotic behavior analysis at the grand strategic level. In fact, data related to arms sales aggregate the influence of many input factors like the political relations between the exporter and the importer of weapons; the political, economic and military balance in the

particular region; the competition for regional dominance; the political and economic relations among exporters of weapons themselves, and so forth. It should be noted that these data meet all the above mentioned requirements and can be easily used for mathematical analysis for chaotic behavior.

#### **(B) STRATEGIC LEVEL OF WAR**

At the strategic level, daily or weekly US fixed-wing aircraft losses during the entire Korean or Vietnam wars can be considered potential data for analysis to determine the presence of chaos in warfare. These data absorb a lot of factors which not only had great impact on outcomes of the wars, but are inextricably linked with each other. Similarly, the data of daily or weekly casualties during the entire Korean or Vietnam wars undoubtedly hold the same promise for the chaotic behavior analysis. In a similar vein, the number of damaged or destroyed targets during the same wars can exhibit chaos. We consider that these data reflect the strategic level because they aggregate information about different services during different operations at different places for the whole period of military conflicts. These data are available in varying degrees of completeness in the US Air Force Historical Research Agency.

#### **(C) OPERATIONAL LEVEL OF WAR**

The data of US casualties during the advance through western Europe in World War II (WWII) can be used for chaotic

behavior determination analysis at the operational level. Another source of data suitable for this analysis is the information about serviceable aircraft of the German Air Force (Luftwaffe) during the Allied air campaign in the European theater of operation.<sup>65</sup>

#### (D) TACTICAL LEVEL OF WAR

At the tactical level, potential sources of data for chaos analysis include supply and maintenance records of specific units during periods of combat, casualties suffered by combat units during a particular battle, or message transmission and reception rates between a unit and higher headquarters while engaged with the enemy. Unit histories contain much of this kind of data, and are available at the US Air Force Historical Research Agency.

## 2. WARGAMES

#### (A) PURPOSE

Since chaos was first identified by Lorenz in a computer simulation and not by observation of a natural phenomenon, it would not be surprising to find chaotic behavior in other computer simulations. It is quite easy to write a short program which produces chaotic output, and it can be done even on a spreadsheet. Furthermore, simple tactical models can exhibit near-chaotic behavior.<sup>66</sup> Our goal was to determine whether or not chaos is present in a wargame which simulates the operational level of war. In such wargames the smallest

units modeled are fairly large and many phenomena are crudely modeled or determined by random draw. These models involve a lot of decision making by the players. By applying mathematical tests to output from the wargame, we hoped to identify the presence of chaos. We could then correlate the presence (or absence) of chaos in war with the presence (or absence) of chaos in a wargame.

#### **(B) SELECTION OF ACES**

We selected the Air Force Command Exercise System (ACES) series of wargames (ACES/PHOENIX, ACES/DRAGON, and ACES/PEGASUS) for several reasons. First, ACES is a theater level wargame and our research is focused on the operational (theater) level of war. Second, ACES is used at the Air War College, Air Command and Staff College, and other comparable Department of Defense organizations for training field grade officers in campaigning and campaign planning. Third, ACES is maintained by Air University's Center for Aerospace Doctrine Research and Education (CADRE) which is located at Maxwell Air Force Base, Alabama, providing convenient access for our research.

#### **(C) DESCRIPTION OF ACES**

ACES is a theater level air campaign simulation which models ground forces at the division level and air forces at the aircraft level. The wargame simulates the air war from the perspective of the Joint Force Air Component Commander's

(JFACC's) staff, exercising the participants in the generation and execution of an Air Tasking Order (ATO). Participants play against other participants, and the computer adjudicates the results of their campaign plans. The participants identify force apportionment, logistical movements, and mission taskings (combat air patrol {CAP} and targets).<sup>67</sup> The wargame simulates the execution of the missions subject to logistics constraints, enemy air defenses, enemy CAP, aircraft capabilities (range, speed, and payload), munitions effectiveness, and airfield survival.

#### (D) DATA AVAILABLE FROM ACES

ACES usually runs for a five-day campaign in cycles which coincide with the ATO cycle. The participants produce an ATO for the next day of the war. ACES executes the ATO and returns the results. Hence the model produces results only once per simulated day.

The following items of interest can be extracted from the ACES engine:

- a. Take-off time (20-minute time increment)
- b. Loss of aircraft from enemy action
- c. Aborted missions due to logistics (including maintenance)
- d. Enemy losses due to air-to-air or air-to-ground combat

### (E) PROBLEMS USING ACES

We were unable to collect useful data from the ACES wargame. Since ACES models activity at a small scale, much information is lumped together. For example, the wargame increments time in 20-minute blocks, and aircraft are launched together. This produces aircraft activity at only five or six times during the day. During a five-day campaign, the wargame generates at most 30 data points, far too small to test for chaos.

We investigated modifying the game to write out information at more frequent intervals, but the fundamental engine driving the game does not appear to model at a detailed enough level to produce the volume of data we required. Furthermore, the five-day length of the campaign would not produce a long enough time series of data, even had the data been available.

We considered other wargames in an attempt to surmount the problem, but they all had the same fundamental problem. A substantial effort by the Wargaming Center to modify the software might produce useful results for future research.

### D. DATA USED FOR CHAOTIC BEHAVIOR ANALYSIS

#### 1. US FIXED-WING AIRCRAFT LOSSES DURING THE VIETNAM WAR, 1962-1973

Some of the data used for the analysis were in fact found at the US Air Force Historical Research Agency. However, locating a suitable data set proved challenging. Numerous computer searches following a variety of logical query schemes

conducted over a matter of days proved futile. A more fruitful approach was interviewing staff historians, which resulted in identification of a document entitled U.S. Navy, Marine Corps, and Air Force Fixed-Wing Aircraft Losses and Damage in Southeast Asia (1962-1973).<sup>68</sup> The document, which the Center for Naval Analysis had prepared under the sponsorship of the Office of the Chief of Naval Operations in August 1976, contained the basic facts concerning the losses of and damages to all USN, USMC, and USAF aircraft in Southeast Asia for the entire duration of the conflict. Microfiche records found with the document contained data files detailing each individual aircraft loss suffered by the respective services in a variety of categories as follows: fixed-wing, in-flight combat losses; fixed-wing in-flight operational losses; fixed-wing ground losses due to enemy action; and fixed-wing on-ground operational losses. Although data were available in other loss categories, we limited our data collection and analysis to those listed.

According to the document's foreword, the data was compiled from all available sources. Primary sources were those that originated as close at hand to the pilot debrief as possible. Secondary sources were usually transcriptions of summaries of primary data, or summaries of data obtained from the squadron or group. Secondary sources included Naval Material Command reports, miscellaneous logs and records, the results of special data collections, and sources outside the operational reporting system.

The definition of combat loss was fairly clear: one due to hostile action, the avoidance of hostile action, or a loss immediately related to the performance of the aircraft's mission function. Examples of combat losses were an aircraft being hit by a surface-to-air missile, one lost due to ground impact while attempting to avoid a missile, or fuel exhaustion due to an air-to-air engagement.

On the other hand, a definition for operational loss was not explicitly provided. The characterization of a given loss as an operational or combat loss, the authors admit, was difficult because operational losses that occur in flight on a combat mission are difficult to define and categorize. The problem was seen as two-fold: determining what defines an operational loss, and gathering enough information about the loss to apply the definition. Apparently, if a loss could not be attributed to a cause qualifying as a combat loss, the authors categorized the loss as operational.

Each combat and operational loss was assigned an incident number, each number appearing in chronological order for each file, including the date and time the incident occurred, and branch of service. The level of detail contained in the microfiche records was far beyond what we needed for our study, but may be useful for other investigators in a future study.

For the purpose of our study, we were interested in a quantitative time series of events. We therefore constructed a simple time series by counting the number of losses per day by loss category and branch of service. Each entry corresponded

to a single day (e.g. 4 Jan 68), loss category (e.g. fixed-wing in-flight combat loss), and branch of service (USN, USMC, or USAF). For each entry, we entered the count of losses for that day, loss category, and branch of service. Then, for the particular purpose of performing mathematical analysis for the detection of chaotic behavior, this daily data was transformed into weekly and monthly data of total aircraft losses.

From our point of view, these data meet all the requirements listed in section III.B. First, it is relevant to the strategic level of war because, as was mentioned above, these data aggregated information about different services during different operations at different places for the whole period of the Vietnam War. Second, the data are presented in time series without any gaps in its sequence. Third, the data provide a relatively large sample size, more than 3,000 entries. Fourth, the data measure some output of warfare during the Vietnam war. Fifth, the data reflect interaction with the enemy. Sixth, the data are an aggregate measure of some aspects of the Vietnam war such as number of sorties, the effectiveness of an enemy air defense and its supply system, flying skills of pilots, aircraft vulnerability and so forth. Seventh, in terms of data reliability, the document's authors detail the painstaking efforts they undertook to compile a complete and accurate record of aircraft losses. Although they admit that not all the data were known for all incidents, different sources reported some conflicting data, and no single source reported all the operational loss incidents, our study

used only a simple count of losses, and ignored the more questionable details surrounding each loss. We therefore considered these data to be reliable and applicable to the analysis of chaotic behavior in warfare.

## 2. US ARMY CASUALTIES IN WESTERN EUROPE DURING WORLD WAR II

Another data set used for chaotic behavior analysis at the operational level of war was daily casualties of the American 12th Army Group in western Europe in WWII from 17 October 1944 through 30 April 1945. The data were provided by the Logistics Management Institute of McLean, Virginia.<sup>69</sup> For the purpose of detailed analysis, four other data sets of daily casualties were extracted from the initial data set: the first set consisted only of Killed In Action (KIA); the second set consisted of KIA, Wounded in Action (WIA) and Captured or Missed In Action (CMIA); the third set consisted of KIA as a percentage of the authorized strength of the 12th Army Group; the fourth set consisted of, daily total casualties as a percentage of the authorized strength of the 12th Army Group. From our point of view, these data also meet all the requirements listed in the section III.B. First, the data are relevant to the operational level of war because these data provide information about casualties during one campaign. Second, the data are presented in time series without any gaps in its sequence. Third, the data provide a relatively large sample size of nearly 200 entries. Fourth, the data measure

some output of warfare during the World War II. Fifth, the data reflect interaction with the enemy. Sixth, the data are an aggregate measure of many aspects of the World War II. Seventh, the data seem reliable because they were collected by military historians who were seriously interested in analyzing operations and campaigns during the World War II.

#### IV. IDENTIFICATION OF CHAOTIC BEHAVIOR

In this chapter we discuss the reliability of the tests for identification of chaotic behavior in data, representing very short time series. After that we present results from application of qualitative and quantitative tests for identification of chaotic behavior in historical data from grand strategic, strategic, and operational level of warfare, as well as in time series, generated by a simple model of arms race between two countries. The results convincingly support the thesis that chaos is present in warfare.

##### A. RELIABILITY OF THE TESTS FOR IDENTIFICATION OF CHAOTIC BEHAVIOR

Chaos theory is relatively new and the methods it uses are often intuitive. Sound proofs for method effectiveness exist only when some limitations apply, i.e. infinite data, absence of noise, etc. Furthermore, the qualitative methods often fail to indisputably prove the presence of chaos.<sup>70</sup> Even in applying quantitative methods, some authors use different techniques (e.g. see the definition of the norm in Eqn. 15 by Green).<sup>71</sup> Because of these problems and to increase the reliability of our results, we used the following techniques:

a. We applied the algorithms to data sets, generated by equations, describing chaotic systems with known fractal dimension.<sup>72</sup> These include:

i. The Lorenz attractor with correlation dimension

2.05

ii. The Henon map with correlation dimension 1.21

iii. The Kaplan-Yorke map with correlation dimension 1.42<sup>73</sup>

b. A reliable method for defining the dimension of a chaotic system should give the same result if the input data is processed by a linear transformation, i.e. multiplication by a constant number, differentiation, integration, etc. The use of historical data, aggregated by months instead of weeks, is approximately equivalent to integration;

c. Use of different methods, measuring related characteristics of a chaotic system.

Figure 11 is an example of the computational problems in the estimation of the fractal dimension.

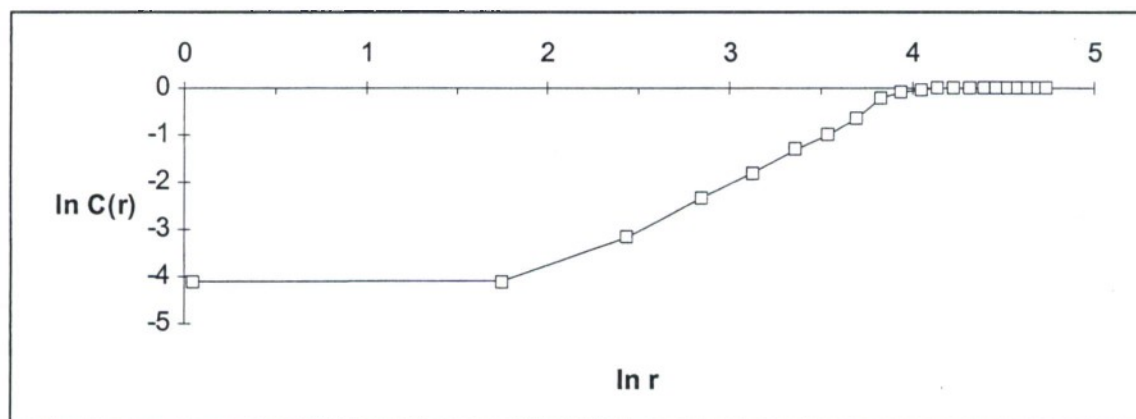

Figure 11.  
 $\ln C(r)$  versus  $\ln r$  for the Lorenz system;  
 variable  $x$ , embedding dimension 13,  
 $\sigma=10$ ,  $r=28$ ,  $b=\frac{8}{3}$

In the whole range of values of  $r$ , the curve  $\ln C(r)$  versus  $\ln r$  is far from linear. Sarigul-Klijn<sup>74</sup> suggests using the region of values of  $r$  between 20 and 80 percent of the maximum radius.

Most of the authors do not specify the term "straight line" (see section II.C.2). Depending on the "linear" section chosen, we estimated fractal dimensions of the Lorenz attractor between 1.99 and 2.12. Compared with the theoretically defined dimension of 2.05,<sup>75</sup> our results can be considered relevant and accurate enough for the goals of the current research.

#### B. CHAOTIC BEHAVIOR ON THE GRAND STRATEGIC LEVEL

As an example of historical data on grand strategic level we used the US defense spending for the last 53 years.<sup>76</sup> Figure 12 represents the time dependence of the defense spending as percentage of the Gross National Product (GNP) and as percentage of the federal outlays.

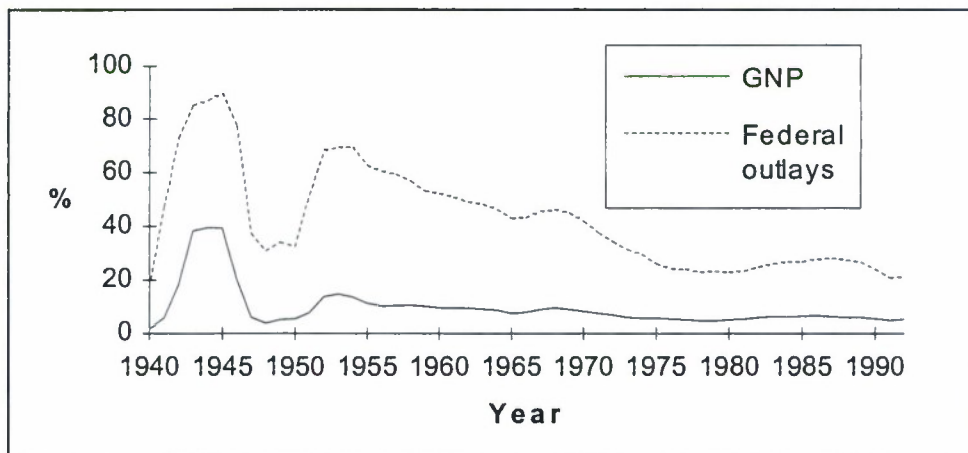

Figure 12.  
Time dependence of US defense expenditures (FY87\$)  
as a percentage of both GNP and federal outlays

The curves have ragged appearance and periodic cycles are not distinguishable.<sup>77</sup> Figure 13 represents the phase space trajectory for the first data set.

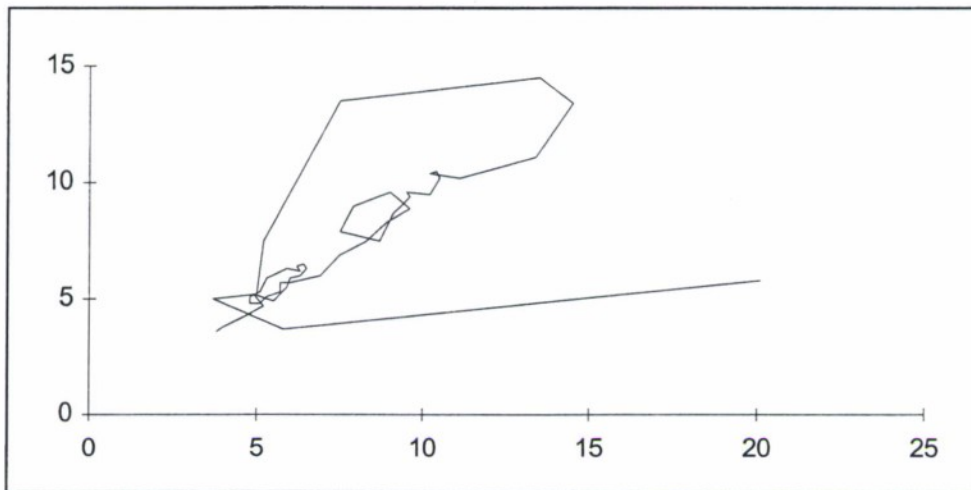

Figure 13.

Phase space trajectory for defense spending as a percentage of GNP. The data for y-axis is constructed from the original data (x-axis) with a time delay of one year.

Though this is hardly an evidence for presence of patterns and attractors, the trajectory is confined in a region of the phase space, which meets one of the qualitative criteria for chaotic behavior. Figure 14 was used to estimate the fractal dimension of possible attractors for both cases. For the first set of data (defense spending relative to GNP) we estimated a dimension of 1.21 (shown by the asymptotic behavior of the curve), and for the second (defense spending relative to federal outlays), 1.07. These low dimensions and fractal dimensions are a clear sign of chaotic behavior.

Another example for presence of chaos on grand strategic level is examined by Grassberger and Pocaccia and presented in Bjorkman.<sup>78</sup>

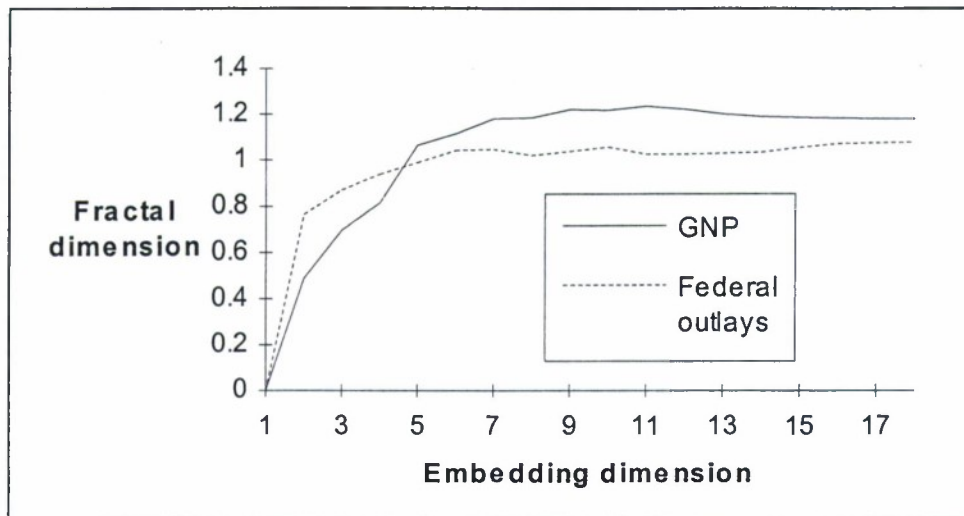

Figure 14.  
Fractal dimension versus embedding dimension  
for US defense spending as a percentage of  
both GNP and federal outlays

Data generated from the arms race model

$$\begin{aligned}
 x_{t+1} &= x_t - k_{11}(x_t - x_s) + k_{12}(1 - x_t)y_t \\
 y_{t+1} &= y_t - k_{22}(y_t - y_s) + k_{21}(1 - y_t)x_t
 \end{aligned}
 \tag{25}$$

are presented in Figure 15.

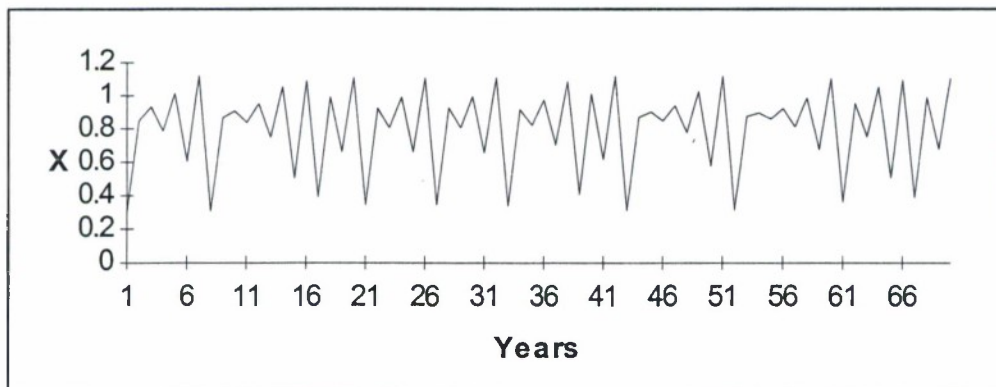

Figure 15. Data generated by the arms race model<sup>79</sup>

The presence of chaos is supported by the qualitative criterion of "ragged" appearance, as well as by the estimated dimension of the attractor of 0.81.

### C. CHAOTIC BEHAVIOR ON THE STRATEGIC LEVEL: US AIRCRAFT LOSSES IN VIETNAM

The autocorrelation function for the aircraft losses in Vietnam is shown on Figure 16.<sup>80</sup>

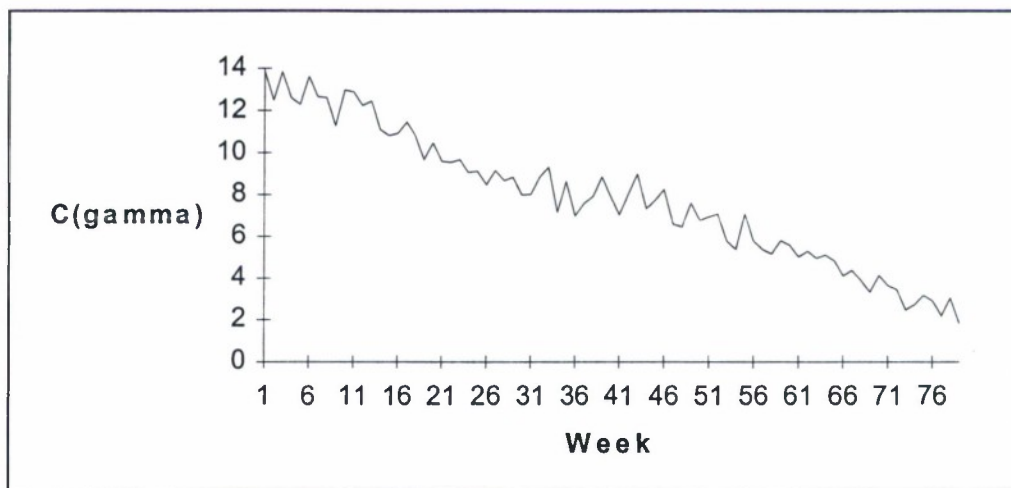

Figure 16.  
Autocorrelation function of the time series  
representing US aircraft losses in Vietnam

Because of the limited amount of data it does not have the textbook smooth appearance. However, the rapid decay is a sign of chaos. Figure 17 represents a case of broad band power spectrum for the same time series, which is typical for chaotic regimes. The above two tests, together with the time dependence shown in Figure 18, meet the qualitative criteria for chaotic behavior.

Figure 17.  
Power spectrum for the aircraft losses in Vietnam.<sup>81</sup>  
X-axis is in cycles per year.  
Y-axis is in losses squared (losses<sup>2</sup>).

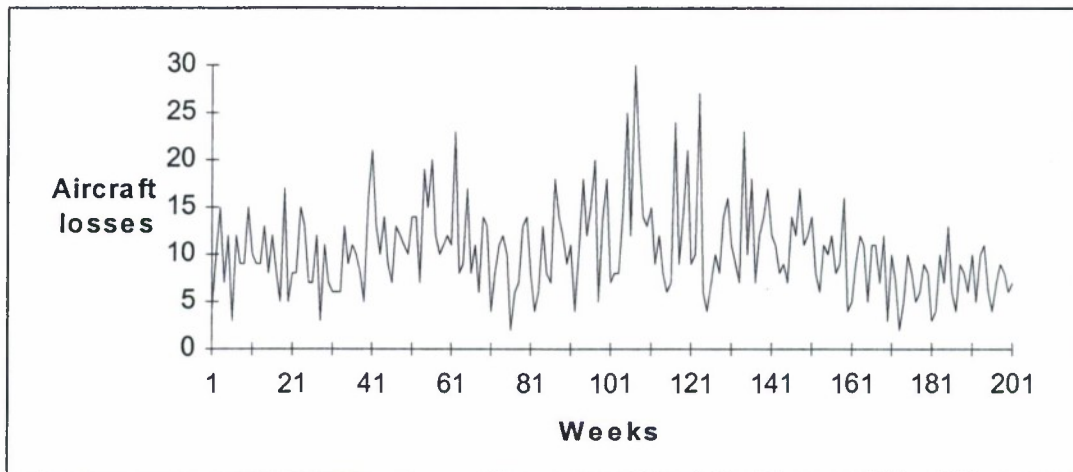

Figure 18.  
Time dependence of the US  
aircraft losses in Vietnam<sup>82</sup>

The presence of chaos on the strategic level is further confirmed by the estimation of the fractal dimension for the same time series. Figure 19 shows the relationship between  $\ln C(r)$  and  $\ln r$  for the 443 points of the weekly data, the slope of which estimates the dimension of the attractor.<sup>83</sup>

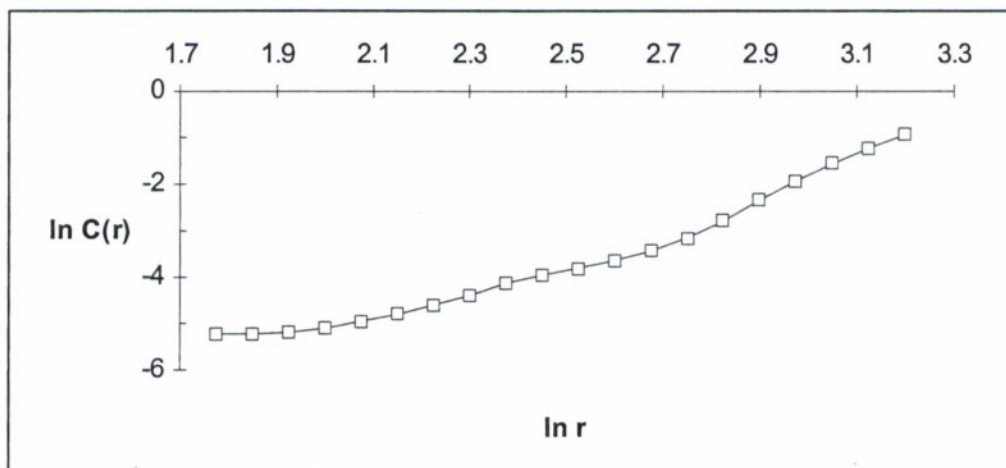

Figure 19.  
 $\ln C(r)$  versus  $\ln r$  for weekly  
aircraft losses in Vietnam

Figure 20 presents the convergence of the estimated fractal dimension for all aircraft losses (2.9) and for the losses in the air (3.2).

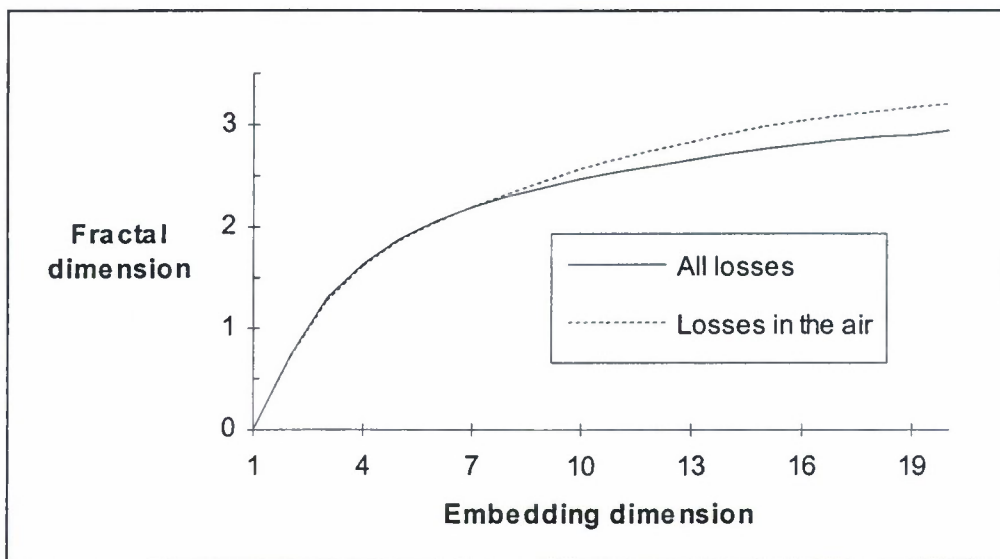

Figure 20.  
Estimated fractal dimension for weekly  
US aircraft losses (as a whole and in the air)

Figure 21 shows the convergence of the estimated fractal dimension for weekly and monthly data. Since the aggregation of the weekly data on a monthly basis is approximately equivalent to the linear operation of integration, the close estimates of the fractal dimension are another confirmation of chaotic behavior and reliability of the tests used.

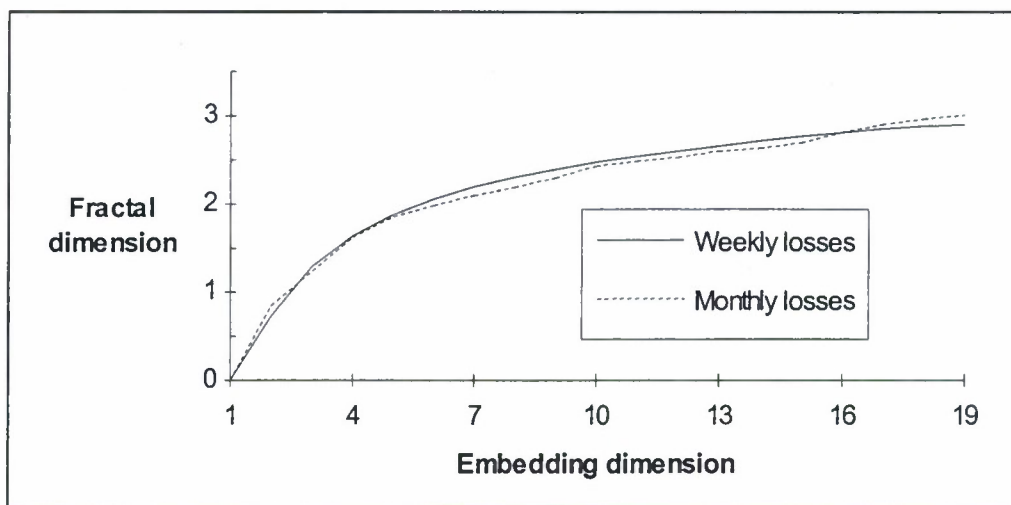

Figure 21.

Comparison between the estimated fractal dimensions for weekly and monthly aircraft losses (all causes)

#### D. CHAOTIC BEHAVIOR ON THE OPERATIONAL LEVEL: WWII CASUALTIES

The two-dimensional phase space trajectory of the US Army casualties (normalized by assigned strength) during the advance through western Europe in World War II is shown in Figure 22. The data for the y-axis is constructed from the same data (x-axis) with a time delay of five days. Figure 23 presents the two-dimensional Poincare map for the normalized casualties.<sup>84</sup> The time series is too short to allow us to discover patterns and attractors, but obviously the map is confined in the phase space, which is one of the qualitative signs for the presence of chaos. Figure 24 shows the convergence of the estimated fractal dimension for soldiers killed in action (3.2), all personnel losses (2.75), and the normalized losses (1.2).

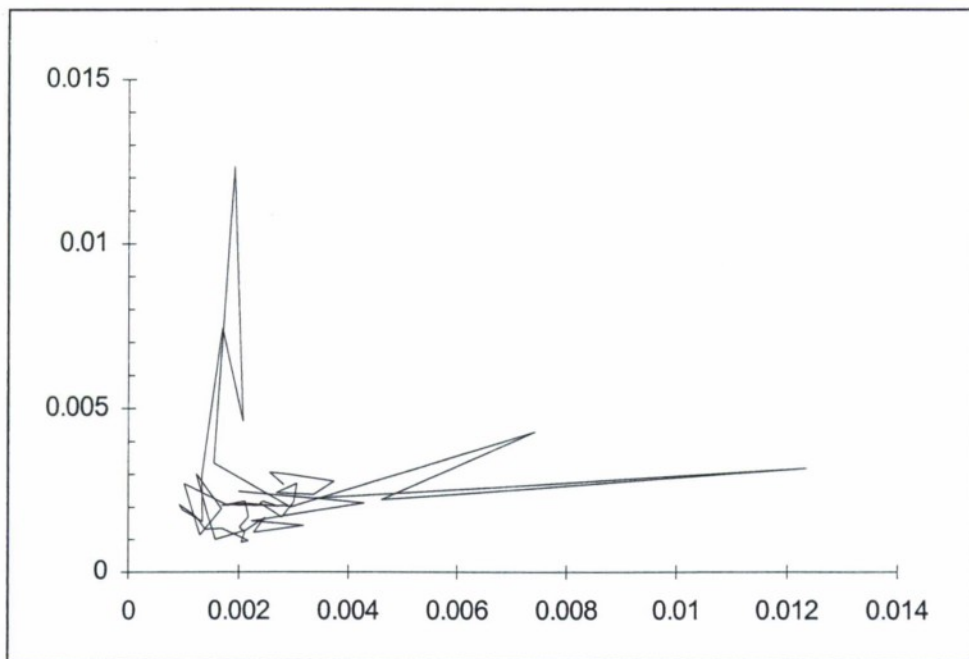

Figure 22.  
Normalized US Army casualties in WWII (trajectory  
in two-dimensional phase space, constructed by a  
time delay of five days)

Somewhat unexpected is the discovery that with the increase of factors taken into account (in the order presented), the fractal dimension decreases.

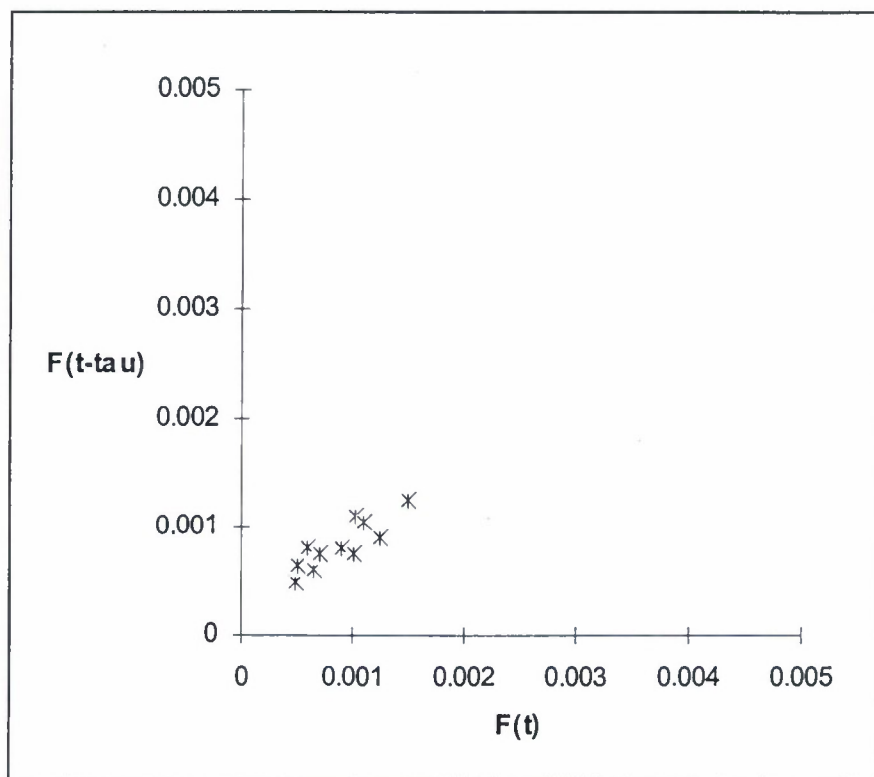

Figure 23.  
 Poincaré map for the normalized WWII casualties.<sup>85</sup>  
 The two-dimensional cross section is of a  
 three-dimensional phase space constructed  
 by a time delay of one and eight days.

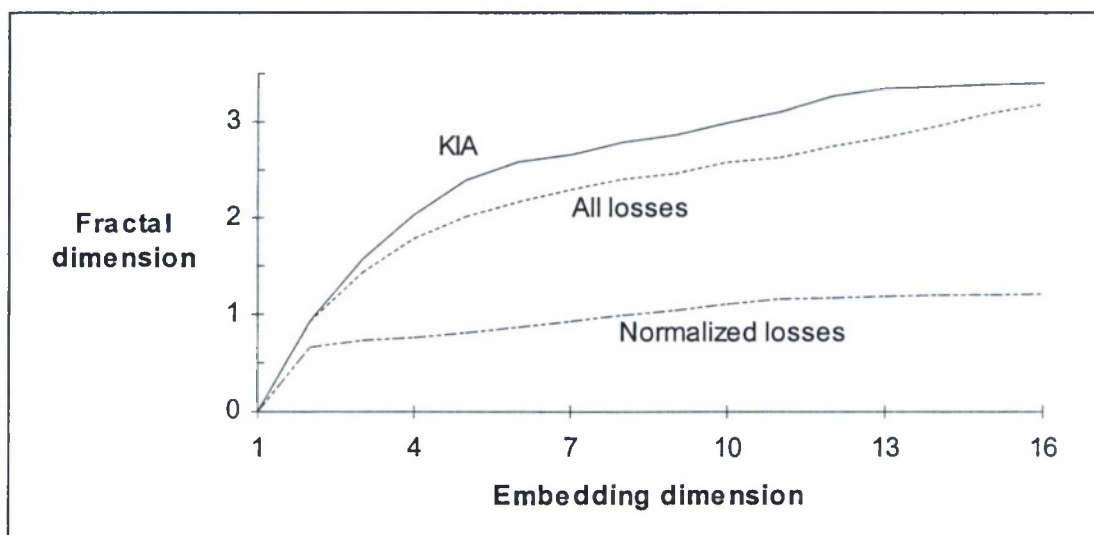

Figure 24.  
 Convergence of the estimated fractal dimensions  
 for three sets of 196 data points for WWII casualties

## V. IMPLICATIONS OF THE PRESENCE OF CHAOS IN WARFARE

Other chaos researchers have attempted to find chaotic characteristics in warfare to demonstrate that warfare is chaotic. While this approach has value, it has the disadvantage that observation of some of the characteristics of chaos in warfare does not mean that warfare is chaotic. For example, Beyerchen<sup>86</sup> has effectively argued that war is nonlinear. However, not all nonlinear systems are chaotic and therefore observation of nonlinearity in warfare does not actually prove that warfare is chaotic. In contrast, having previously focused on a mathematical approach to show that chaos is present in war, we will now reverse the above logic. That is, we can say that if war is chaotic, then it must have the characteristics of a chaotic system. We will now attempt to list the characteristics of chaotic systems and define what they mean in the context of warfare.

### A. CHAOTIC SYSTEMS ARE DETERMINISTIC

All chaotic systems must be at least partly deterministic.<sup>87</sup> That is to say, given a knowledge of current conditions, the conditions in the very near future must be predictable. Therefore, if warfare is chaotic, then it too must be partly deterministic. Unfortunately, what is meant by the very near future is complicated by the preciseness of our knowledge of the present and the possibility of chance. Clausewitz recognized these phenomena as fog and friction.

What does it mean, however, to say that warfare is at least partly deterministic? In a physical system, determinism means that there are equations or rules which describe the behavior of the system. The equations that Lorenz used to predict the weather are an example of this.<sup>88</sup> If warfare is deterministic, then it too must obey a set of rules. The particular set of rules that are obeyed would depend upon the aspect of war being examined. For example, at the tactical level of war, bombing effectiveness may be governed by rules such as "a B-52 dropping twenty 500 pound bombs from 10,000 feet has a 50% chance of hitting a 10-foot by 10-foot target." At the operational level of war, the outcome is determined by the decisions and the behaviors of the participants. Therefore, if operational warfare is chaotic, the decisions and behaviors of the individuals and groups participating in the war must follow a set of rules.

In fact, it appears that the behavior of human beings, individually or in groups, does follow rules. If human behavior did not have any rules, if it were completely random, we would not be able to predict behavior at all. In reality, the better we know someone, the better we are able to predict their behavior. This is because we understand the rules that govern their behavior. In particular, the process of strategic decision making, which is a key element in operational warfare, has been shown to demonstrate chaotic behavior.<sup>89</sup>

The presence of chaos in warfare means that there are rules that govern warfare and that it should sometimes be possible to

predict enemy response if we take the trouble to learn the rules that govern his behavior. Put another way, this is Sun Tzu's conclusion of "know your enemy."<sup>90</sup> The following sections will build on this foundation by suggesting ways that chaos theory can help us develop and use models of warfare.

#### **B. COMPUTER SIMULATION CAN GREATLY ENHANCE OUR UNDERSTANDING**

Computer numerical modeling or simulation has greatly increased our understanding of physical chaotic systems. The reason for this is that the equations that govern chaotic systems are nonlinear and therefore are generally not analytically soluble. Computer simulation has also been successfully used to model the behavior of living beings such as the flocking of birds and the variation of population levels.<sup>91</sup> The Sante Fe Institute has been able to model the behavior of bubbles and crashes in the stock market using their concept of a complex adaptive system.<sup>92</sup> Their postulates for the behavior of complex, adaptive systems included the following. First, there are many independent agents and it is their interaction that determines the nature of the system. Second, complex adaptive systems consist of many organizational levels that are constantly changing based upon experience. Third, each agent anticipates the future based upon their experience. These postulates appear to be equally applicable to warfare, which suggests that complex, adaptive, computer

simulations might be a useful approach to modeling warfare as well.

Chaos theory, however, cannot be used by itself to derive a theory of warfare. As with any other theory that describes a phenomenon, a theory of warfare must be based upon observation, hypothesis and testing. Specifically, development of a model of warfare will require the development of the structure of the model, determination of the number and type of variables, and determination of the form of the equations. In addition, system parameters and control factors will have to be identified as well as sources for noise. This will be a very difficult task, and it is not at all certain that different models might not apply, depending on the nature of the antagonists.

Chaos theory can help us by suggesting ways to develop our model and ways to use the model once developed. For example, observation of a chaotic system can be used to determine the dimension of the system. The number of variables needed to describe the system must at least equal the dimension of the system. Therefore, chaos theory can be used to define the minimum number of variables required in our computer model. Chaos theory also suggests that computer models of warfare must contain some nonlinear relationships between system variables so that the computer model is chaotic and thus reflects the chaotic nature of warfare. This may actually prove to be advantageous as the fractal nature of chaotic systems may allow relatively small and simple wargames to accurately simulate

warfare. Realistic wargames that could be run on a desktop computer would have significant educational and operational advantages. Finally, the Kolmogorov entropy can be calculated for a chaotic system. The Kolmogorov entropy is a measure of how fast information is lost in a chaotic system and thus indicates how far into the future predictions can reasonably be made.

The ways in which computers have been used to understand chaotic behavior in physical systems also suggest ways to use the computer to model warfare. For example, consider Lorenz' model of the weather. The reader has probably noted that weather forecasting has not become perfect because of Lorenz' equations. This criticism, however, misses one of the most important contributions that chaos theory has made to weather prediction -- chaos has given weather forecasters a means to determine whether their forecasts are likely to be accurate. Chaotic systems are highly dependent upon initial conditions but they are not always equally so. If a chaotic system is in a portion of its phase space where the initial conditions are critical, then uncertainty in determining the initial conditions makes a large number of outcomes possible. If a chaotic system is in a region of its phase space where the initial conditions are not critical, then only one outcome (prediction) is likely. In practice, weather forecasters use this behavior by inputting small changes in initial conditions into their model. If the small changes produce small variations in the prediction then they have shown that the

system is in a portion of phase space where the initial conditions are not critical and their prediction is likely to be true. If the minor changes in initial conditions produce large deviations in future behavior, they know that their prediction is likely to be in error.

The same approach could be taken to understand when predictions in warfare are likely to be accurate. This in itself would be a valuable contribution of computer simulation to understanding warfare. But there are two additional reasons why this approach may be even more applicable to warfare than it is to weather. First, unlike weather forecasters, we have some ability to change the initial conditions. Specifically, if we find ourselves in a region of great uncertainty, we could explore what aspects of the conditions would have to be changed to move the system to a position where it was relatively independent of the initial conditions and where the predicted outcome was desirable. The quantity and type of forces are an example of initial conditions that we might be able to change. Second, we could use our model to determine which initial conditions and which variables had the most profound effect on our predictions. This would aid in identifying centers of gravity (COGs) and identify information that we needed to know precisely. That is, it would tell us where to concentrate our attack and what intelligence information was most critical.

The behavior of many chaotic systems, such as a dripping tap, is apparently random in the short term. But, if enough data are collected, patterns emerge in the phase space of the

system that reveal excluded states. In other words, there are things that will not happen. Social systems, such as the stock market or an enemy, do not generate data as quickly and so it may take many years to discern patterns. In fact, one researcher has claimed that in order to use chaos to fully discern the patterns in the stock market, almost 7,000 years of data would have to be available.<sup>93</sup> The situation is further complicated in warfare where there are often reasons why data is obscured to begin with. Computer models could be used to simulate many years of data -- enough so that patterns became evident. Caution would be required in using these results as they would be an extrapolation with all the dangers inherent in extrapolation. The value of this technique would lie in suggesting possibilities of enemy behavior and weaknesses that could then be tested.

### C. CHAOTIC SYSTEMS ARE DYNAMIC

All chaotic systems are dynamic. So, if war is chaotic, then it too must be dynamic (this also agrees with experience). If a system is dynamic then the important parameters that describe the state of the system are constantly changing. In the physical example of a pendulum, potential energy, a maximum when the pendulum is at its height, is converted into kinetic energy which reaches a maximum at the bottom of the swing. As the pendulum rises, the kinetic energy is once again converted into potential energy. Understanding these sources of power is crucial in attempting to understand a dynamic system. Indeed,

Pentland<sup>94</sup> has argued that these sources of power and the processes for their transformation will often be COGs for operational systems.

For societies, Pentland describes the sources of power as being the armed forces, the government bureaucracy, industry and natural resources, society and culture, and the value system. He relates these sources of power to the forces (or the instruments of power) that they produce -- military, political and diplomatic, economic, social-cultural, and ideological. For societies, one example of the flow of power from one measure of the system to another is the conversion of economic power into military power. Pentland also points out that these sources of power, in combination with their linkage to instruments of power, and feedback control loops, can be the COGs for the system.

We have just discussed how the values that describe a dynamic system are constantly changing. Nonlinearity of the system complicates analysis still further because the future behavior of a nonlinear, chaotic system is highly dependent upon the conditions now. Chaos theory, in fact, says that it is impossible to use present conditions to predict very far into the future for a chaotic system. Even in a dynamic system, however, there are things that don't change. In a pendulum, the mass and the length of the pendulum are constant. Also, even though kinetic and potential energies are constantly changing, the sum of kinetic and potential energies remains constant. The sum of energies has proven such an immensely

useful technique for analyzing dynamic, mechanical systems that it has been given a separate name -- the Hamiltonian. Analyses of dynamic systems rely on identifying aspects of the system that are constant and identifying processes for change -- such as potential energy into kinetic energy for a pendulum.

If warfare is dynamic, then similar approaches should be applicable. This suggests that emphasis should be placed not on the current values of the system (e.g. the number of tanks at a particular location) but on the processes (such as how the logistics operation moves tanks) and on the things that are relatively constant (such as industrial capacity). Both are important to understanding the capability of a system. Understanding the processes, however, would be especially important to identifying the vulnerabilities of a system.

#### **D. CHAOTIC SYSTEMS ARE NONLINEAR**

All chaotic systems are nonlinear. Among other things, nonlinearity means that a small effort can have a disproportionate effect. Some methods for the control of physical chaotic systems have explicitly taken advantage of this with the result that they have dramatically reduced the amount of effort required to control the system.<sup>95</sup> If warfare is chaotic, then chaos theory suggests COGs may be found where there is a nonlinear process in the enemy's system. In fact, nonlinearity is implicit in the concept of a COG. The following paragraphs will discuss six of the many sources for nonlinearity in warfare.

Feedback loops are one process that can introduce nonlinear effects in many systems. A feedback loop that is important to the air campaign is the feedback that attrition rates give to an air commander. If the attrition rates are too high, then the commander is forced to change his tactics. For example, the loss rates of 16% that were experienced by the US in the daylight bombing raids over Schweinfurt were enough to stop the bombing raids for four months until a long range fighter was developed. Warden<sup>96</sup> used this and other historical examples to argue that the maximum acceptable rate was about 10%. He continued, however, by pointing out that the effect of one mission with a 10% attrition rate and nine missions with negligible casualties was much greater than a steady 1% attrition rate over ten missions. In a linear system there would be no difference between the two -- the additive effects would be the same. The fact that there is a difference shows that the feedback is nonlinear. When Warden suggested that massing for a few devastating blows is more effective than many minor blows, he effectively analyzed the feedback loop and exploited the nonlinearity in the system.

A second source for nonlinearity in warfare is the psychology associated with interpreting enemy actions. It is this nonlinearity that caused Clausewitz to state that, "Thus, then, in strategy everything is very simple, but not on that account very easy."<sup>97</sup> He later amplified by saying that while such maneuvers as a flanking movement are simple in concept they are difficult to actually accomplish because there is

always the danger of what the enemy might be doing. In this environment, small actions on the part of your enemy often assume larger significance in a commander's mind than they deserve. According to Liddell Hart,<sup>98</sup> this happened in World War I before the first Battle of the Marne. The Germans, aware of a possible seam in their dispositions, had been ordered to retreat if the British Army advanced over a particular river. As it happened, a British division sent out a reconnaissance patrol. This was misinterpreted by the Germans as a general advance and so they retreated when the way lay open for victory.

A third source for nonlinearity is that each side is constantly reacting to the other. This is such a necessary condition for warfare that if one side loses the ability to react they are strategically paralyzed and will quickly lose the war. The interaction between the opposing sides can quickly become a highly nonlinear positive feedback loop. One example of such a nonlinearity is the way in which one side in a conflict adapts to technological or tactical innovation on the other side. According to Luttwak,<sup>99</sup> minor innovations are often ignored by an enemy. Major innovations, however, require immediate attention and may paradoxically be less damaging because they lose their effectiveness in a short period.

A fourth source for nonlinearity in warfare is that there are a number of processes within warfare that appear to be inherently nonlinear. The role of mass is an important example for warfare. Warden showed that for air power, losses vary

disproportionately with the ratio of the forces involved.<sup>100</sup> For example, in 1944, 287 American aircraft attacked a target where they were opposed by 207 German fighters. The Americans lost 34 aircraft. A month later, when 1,641 American aircraft were opposed by 250 German fighters, America lost 21 aircraft which is a lower percentage and a lower absolute number.

A fifth source of nonlinearity in warfare is Clausewitzian friction. This kind of nonlinearity in warfare has been ably argued by Beyerchen.<sup>101</sup> Basically, there will be events in war, perhaps as a result of chance, that have an effect all out of proportion to their apparent importance. This notion is captured in the following nursery rhyme.

For the want of a nail the shoe was lost.  
 For the want of the shoe the horse was lost.  
 For the want of a horse the message was lost.  
 For the want of a message the battle was lost.  
 For the want of a battle the kingdom was lost.  
 And all for the want of a horseshoe nail.<sup>102</sup>

By its very nature, this is an exceedingly difficult form of nonlinearity to anticipate but it can be taken advantage of once it happens. The German doctrine of Auftragstaktik, which allowed initiative on the part of junior commanders, was designed to do precisely this.

Finally, the process of decision making itself can be a source for nonlinearity. Sometimes the decision is clear cut. Often, however, the decision can depend upon relatively minor circumstances at the time. One source<sup>103</sup> suggests that the steam engine lost out to the gasoline internal combustion

engine largely as a result of an outbreak of hoof and mouth disease. This outbreak meant that many horse troughs had to be removed that had been used as a convenient place for steam engines to top up on water. Once the decision is made, it is often irreversible because of the drive for standardization. The QWERTY keyboard, for example, arose out of a need to slow typists down.<sup>104</sup> The mechanical typewriters of the time could not keep up. Once it became common, people knew how to use the QWERTY keyboard and it has now become nearly impossible to change it, although it is no longer necessary to slow typists down. These examples illustrate how any major decision, including those made in wartime, can be nonlinearly based on relatively minor factors.

In summary, chaos theory suggests that the campaign planner should concentrate on processes in an enemy system rather than data on its current condition because you can't predict future behavior based on initial conditions.<sup>105</sup> It also suggests that identification of nonlinear processes, such as feedback loops, is an essential ingredient in understanding warfare and being able to manipulate the outcome with the least effort.

#### **E. FRACTAL GEOMETRIES APPLY**

Fractal geometries are a direct result of a chaotic system's insensitivity to scale. Physically, this means that a chaotic system looks the same whether viewed from close up or from far away. There are many examples of fractals in nature such as clouds or mountain ranges. Two major conditions must

be true for systems to scale in this way. First, the same laws and variables must be present in the system at both the large and the small scales. In turbulent flow, for example, hydrodynamics are constant whether one is speaking of a river or an eddy. Second, the elements of the system must exist in a continuum. In the previous example of fluid flow, the flow would no longer look like a flow if we were on such a small scale that we could see the individual molecules.

If warfare is chaotic, then aspects of it must be fractal. This has implications for the analysis of an enemy system. First, the attractor for a chaotic system is fractal and so is infinitely complex. Efforts to analyze every aspect of an enemy's system are, therefore, bound to be in vain as there will always be some finer level to analyze. Second, behaviors at the tactical, operational, and strategic levels are linked. If a technique is successful at one level then we can expect it to be successful at all levels. This suggests that we should, when possible, try out strategies on a small scale where the consequences of losing are inconsequential. It also suggests that analysis techniques that are useful on one level may be useful on others. An example of this is the O-O-D-A loop<sup>106</sup> which was originally proposed for the tactical level of one-on-one fighter combat.<sup>107</sup> The O-O-D-A loop, however, has since been widely applied to operational level concepts such as information dominance. Third, if the small scale is similar in behavior to the large scale, then we can use observation of the small scale to predict the behavior of the large scale. For

example, Admiral Yamamoto was fond of playing Shogi. Agawa, in his biography of Admiral Yamamoto,<sup>108</sup> noted that his style of playing this game was to risk everything on a bold, early stroke. If that failed, then Admiral Yamamoto would often lose the game. Agawa suggests that this philosophy was behind the way in which Admiral Yamamoto planned his large campaigns -- such as Pearl Harbor and Midway.

A fractal nature of war also has implications for the way we should organize for war. Sun Tzu implied a fractal nature of war when he said, "Generally, management of many is the same as management of few."<sup>109</sup> This indicates that he thought that the principles of organizing to fight were the essentially the same regardless of the scale of the fight. Some principles, such as span of control, appear to be similar regardless of organizational level. Overall, although research on the implications of chaos for organizational structures has started, conclusions are far from certain.

#### **F. MULTIPLE ATTRACTORS ARE POSSIBLE**

Multiple attractors are possible in a chaotic system. Gleick uses the example of a common pendulum toy to describe a chaotic system with multiple attractors.<sup>110</sup> This toy consists of a metal bob on the end of a string that is allowed to swing not just back and forth but in any direction. At the base of the pendulum are a number of magnets that attract the bob. After the bob is set in motion, it swings erratically from magnet to magnet, eventually being captured by one of them.

When the bob is first set in motion it is impossible to predict which of the magnets (attractors) will ultimately capture the bob. However, eventually one of them does. Starting the bob from an infinitesimally different position will cause it to come to rest at a different magnet. Therefore, the magnets provide multiple stable states for the bob's final resting position.

Similarly, organisms can exist in different states. One species of ameba usually exists as single cells. If they are starved, they respond by aggregating into a multicellular body called a plasmodium.<sup>111</sup> This plasmodium is capable of moving to seek more favorable conditions. After migration, the body of the plasmodium differentiates into a stalk and a fruiting body. If conditions are right, the fruiting body produces spores which again become single cell amebas.

In an analogous fashion, armed forces can drastically change their organization and means of fighting a war. An example of this can be found in the People's War of Mao Tse Tung. He divided the phases of war up into different stages. In some stages, his army fought a guerrilla war as small units. Only later, when conditions were right (i.e. the opposing armies had been sufficiently weakened), did he combine his units into a conventional force. If warfare is chaotic, then chaos theory warns us that enemy systems can exist in different states. The implications are that we must be aware of these possible states and, if necessary, be capable of changing our own system state to counter the enemy strategy. Chaos theory

also warns us that the transition from one state to another can be very fast.

## VI. CONCLUSIONS

1. Fractal dimensions were measured for the systems described by World War II casualty data, Vietnam War aircraft loss data, and US defense spending data. In addition, strange attractors were observed for the World War II and the defense spending data.

2. These observations demonstrate that warfare is chaotic at the strategic, operational, and tactical levels.

3. These observations also demonstrate that warfare must demonstrate the characteristics of a chaotic system. Specifically, warfare must be dynamic, nonlinear, fractal, and at least partly deterministic. In addition, warfare may have multiple attractors.

4. Similarly, these observations suggest that the tools of chaos science should be used to enhance our understanding of warfare. Computer simulation is an important example of such tools.

5. Aggregating data, such as normalizing casualty data by authorized strength, was found to reduce the fractal dimension of the system. This may have implications for the future modeling of war.

## APPENDIX

```

program EstimFractDim;

    { ESTIMATION OF THE FRACTAL DIMENSION OF CHAOTIC SYSTEMS }
    { Software in support of the AY94 research project }
    { "Chaos in War: Is It Present and What Does It Mean?" }
    { Author of the software - Major Todor D. Tagarev - }
    { Bulgarian Air Force; version as of 10 April 1994 }
    { TurboPascal(TM) 5.5 }

uses Crt,Sdeq,Math,Tgraph;

const JM=443;      { Number of data points }
      JRmax=30;    { Number of points on the curve C(r) vs r }
      JVmax=10;    { Maximum embedding dimension }
      dmin=0.1;    { Lower limit of the slope of the curve }
      Sigmamax=0.1; { Upper limit of the mean square }
      N=3;         { Number of differential equations }
      D=0.1;       { Step of integration }

type Tarray      = array[1..jm] of real;
   CorArray      = array[1..jrmax] of real;
   EmbArray      = array[1..jvmax] of real;
   Marray        = array[1..n] of real;
   Auxarray      = array[1..n,1..8] of real;
   Prmarray      = array[1..5] of real;

var X,Y,Z        :Tarray;      { Phase State Variables }
    r,CorCoef,LnC,Lnr,Slope    :CorArray;  { Radius,... }
    SysDim,A,sigma            :EmbArray;    { Approximating Straight Line }
    yl,dery                :Marray;        { used by RK }
    prmt                    :Prmarray;     { used by RK }
    aux                      :Auxarray;    { used by RK }
    Xmin,Xmax,T              :real;
    SumC,Sumr,SumCr,Sumr2,Sumz :real;

    FileName,Zapis,StringHlp  : String;
    FileIn                    : File of Char;
    Charact                    : Char;

    i,j,jr,jv                :integer;
    k,i1,i2,j1,jmm           :integer;
    k1,k2,broi                :integer;
    Demb                      :integer;    { * Embedding Dimension * }
    Sum,Sum2,r0               :real;

procedure dataHenonMap;      { * HENON MAP * }
const a=1.4; b=0.3;
begin
  x[1]:=0.5; y[1]:=0.5;
  for i:=1 to jm-1 do
    begin
      x[i+1]:=1.0+y[i]-a*x[i]*x[i];
      y[i+1]:=b*x[i];
    end
end

```

```

    end;
end;

procedure dataLogisticMap;          { *   LOGISTIC MAP   * }
var b: real;
begin
  b:=1.0;
  x[1]:=0.7;
  for i:=1 to jm-1 do
    begin
      x[i+1]:=4.0*b*x[i]*(1.0 - x[i]);
    end;
  end;

procedure dataKaplanYorke;        { *   KAPLAN-YORKE MAP   * }
                                   { After Grassberger-Procaccia'83 }
const alpha=0.2;
begin
  x[1]:=0.7;
  y[1]:=pi/4.0;
  for i:=1 to jm-1 do
    begin
      y[i+1]:=2.0001*y[i];
      if y[i+1]>1.0 then y[i+1]:=y[i+1]-1.0;
      x[i+1]:=alpha*x[i] + cos(4.0*pi*y[i]);
    end;
  end;

procedure dataRandom;             {   Uncorrelated number series   }
                                   {   Normal Distribution   }
                                   { Procedure Gauss is in unit Math }
                                   { Author: Marin Raikov, Bulgarian }
                                   {   Air Force Academy   }
begin
  for i:=1 to jm do
    x[i]:=Gauss(0.0,1.0);
  end;

procedure dataArmsRace;

    { * Grossmann, Mayer-Cress, 1989 * }

{The results differ from those presented in "Chaos Primer"}

var Xs,Ys,k11,k12,k21,k22: real;
begin
  Xs:=0.1;  Ys:=0.1;
  k11:=0.4; k22:=0.4;
  k12:=3.0; k21:=3.0;
  x[1]:=0.3; y[1]:=0.3;  { Initial conditions }
  for i:=1 to jm-1 do
    begin
      x[i+1]:=x[i] - k11*(x[i]-Xs) + k12*(1.0 - x[i])*y[i];
      y[i+1]:=y[i] - k22*(y[i]-Ys) + k21*(1.0 - y[i])*x[i];
    end;
  end;
end;

```

```

{$F+}
procedure Fct(T:real;var y1,dery:marray);
  const sigma=10.0; r1=28.0; b=2.6666667;
  begin
    dery[1]:= - sigma*y1[1] + sigma*y1[2];
    dery[2]:= - y1[1]*y1[3] + r1*y1[1] - y1[2];
    dery[3]:=  y1[1]*y1[2] - b*y1[3];
  end;
procedure Outp(T:real;var y1,dery:marray;var prmt:prarray;k,n:integer);
  begin
    i:=i+1;
    x[i]:=y1[1];
    y[i]:=y1[2];
    z[i]:=y1[3];
    if i=jm then prmt[5]:=1.0;
  end;
{$F-}

```

```

procedure dataLorenz;
{
  Lorenz Attractor
  Integration by Runge-Kutta 4
  uses procedures Fct and Outp
  Procedure RK is in unit Sdeq
  Author: Marin Raikov, Bulgarian Air Force Academy
}
begin
  y1[1]:=2.0; y1[2]:=2.0; y1[3]:=12.0;{ Initial conditions }
  i:=1;
  x[1]:=y1[1];
  y[1]:=y1[2];
  z[1]:=y1[3];
  prmt[1]:=0.0;
  prmt[2]:=10000.0*jm*D;
  prmt[3]:=D;
  prmt[4]:=1.0e-4;
  prmt[5]:=0.0;
  RK(n,T,y1,dery,prmt,aux,@Fct,@Outp,k);
end;

```

```

procedure dataVietMonth;
{
  US aircraft losses in Vietnam - Monthly data
  102 points
  { x - all losses
  { y - losses on the ground
  { z - losses in the air
}
begin
  FileName:='A:\VIETM.CSV';
  Assign(FileIn,FileName);
  Reset(FileIn);
  Zapis:='';
  StringHlp:='';
  j:=1;
  While NOT EOF(FileIn) Do
  begin
    Read(FileIn,Charact);
    if Ord(Charact)=13 then
      begin

```

```

StringHlp:='';
k1:=Pos(',',Zapis);
  for k:=1 to k1-1 do
    StringHlp:=StringHlp+Zapis[k];
  Val(StringHlp,z[j],k2);
  Delete(Zapis,1,k1);
  StringHlp:='';
  k1:=Pos(',',Zapis);
    for k:=1 to k1-1 do
      StringHlp:=StringHlp+Zapis[k];
    Val(StringHlp,y[j],k2);
    Delete(Zapis,1,k1);
    StringHlp:='';
  k1:=Length(Zapis);
    for k:=1 to k1 do
      StringHlp:=StringHlp+Zapis[k];
    Val(StringHlp,x[j],k2);
    j:=j+1;
    Zapis:='';
  end
  else
  begin
    if Ord(Charact) <> 10 then Zapis:=Zapis+Charact;
  end;
end;
Close(FileIn);
end;

procedure dataVietWeek;
  { US aircraft losses in Vietnam - Weekly data }
  { 443 points }
  { x - all losses }
  { y - losses on the ground }
  { z - losses in the air }

Var Days1,days2,days3: Array[1..7] of real;
begin
  FileName:='A:\VietDay.CSV';
  Assign(FileIn,FileName);
  Reset(FileIn);
  Zapis:='';
  StringHlp:='';
  for j:=1 to jm do
    begin
      x[j]:=0.0; y[j]:=0.0; z[j]:=0.0;
    end;
  j:=1;
  i:=1;
  While NOT EOF(FileIn) Do
  begin
    Read(FileIn,Charact);
    if Ord(Charact)=13 then
    begin
      StringHlp:='';
      k1:=Pos(',',Zapis);
      for k:=1 to k1-1 do
        StringHlp:=StringHlp+Zapis[k];

```

```

Val (StringHlp, Days1 [i], k2);
Delete (Zapis, 1, k1);
StringHlp := '';
k1 := Pos (' ', Zapis);
  for k := 1 to k1 - 1 do
    StringHlp := StringHlp + Zapis [k];
Val (StringHlp, Days2 [i], k2);
Delete (Zapis, 1, k1);
StringHlp := '';
k1 := Length (Zapis);
  for k := 1 to k1 do
    StringHlp := StringHlp + Zapis [k];
Val (StringHlp, Days3 [i], k2);
i := i + 1;
Zapis := '';
if i = 8 then
begin
  i := 1;
  for k := 1 to 7 do
  begin
    z [j] := z [j] + Days1 [k];
    y [j] := y [j] + Days2 [k];
    x [j] := x [j] + Days3 [k];
  end;
  j := j + 1;
end;
end;
else
begin
  if Ord (Charact) <> 10 then Zapis := Zapis + Charact;
end;
end;
Close (FileIn);
end;

procedure dataMilBudget;
{
  Budget of US government: FY 1993
  {
    53 points
  }
  { x - defense spendings as percentages of GNP
  }
  { y - defense spendings as percentages of outlays }
begin
  FileName := 'A:\BUDGET.CSV';
  Assign (FileIn, FileName);
  Reset (FileIn);
  Zapis := '';
  StringHlp := '';
  j := 1;
  While NOT EOF (FileIn) Do
  begin
    Read (FileIn, Charact);
    if Ord (Charact) = 13 then
    begin
      StringHlp := '';
      k1 := Pos (' ', Zapis);
      for k := 1 to k1 - 1 do
        StringHlp := StringHlp + Zapis [k];
      Val (StringHlp, x [j], k2);
    end;
  end;
end;

```

```
Delete(Zapis,1,k1);
StringHlp:='';
k1:=Length(Zapis);
  for k:=1 to k1 do
    StringHlp:=StringHlp+Zapis[k];
  Val(StringHlp,y[j],k2);
  j:=j+1;
  Zapis:='';
end
      else
```

```

begin
  if Ord(Charact) <> 10 then Zapis:=Zapis+Charact;
end;
end;
Close(FileIn);
End;

procedure dataWWIIcasualties;
  { 12 US Army Group - Advance trou Western Europe }
  { 196 points - dayly data }
  { x1 - Killed in Action }
  { x2 - Wounded in Action }
  { x3 - Captured/Missing in Action }
  { x4 - Assigned Force }
  { x - all losses/Assigned Force }
var x1,x2,x3,x4: real;
begin
  FileName:='A:\CasWWII.CSV';
  Assign(FileIn,FileName);
  Reset(FileIn);
  Zapis:='';
  StringHlp:='';
  j:=1;
  While NOT EOF(FileIn) Do
  begin
    Read(FileIn,Charact);
    if Ord(Charact)=13 then
    begin
      StringHlp:='';
      k1:=Pos(',',Zapis);
      for k:=1 to k1-1 do
        StringHlp:=StringHlp+Zapis[k];
      Val(StringHlp,x1,k2);
      Delete(Zapis,1,k1);
      StringHlp:='';
      k1:=Pos(',',Zapis);
      for k:=1 to k1-1 do
        StringHlp:=StringHlp+Zapis[k];
      Val(StringHlp,x2,k2);
      Delete(Zapis,1,k1);
      StringHlp:='';
      k1:=Pos(',',Zapis);
      for k:=1 to k1-1 do
        StringHlp:=StringHlp+Zapis[k];
      Val(StringHlp,x3,k2);
      Delete(Zapis,1,k1);
      StringHlp:='';
      k1:=Length(Zapis);
      for k:=1 to k1 do
        StringHlp:=StringHlp+Zapis[k];
      Val(StringHlp,x4,k2);
      x[j]:=(x1 + x2 + x3)/x4;
      writeln(x1:8:1,x2:8:1,x3:8:1,x4:11:1,x[j]:13:8);
      j:=j+1;
      Zapis:='';
    end
    else

```

```

begin
  if Ord(Charact) <> 10 then Zapis:=Zapis+Charact;
end;
end;
Close(FileIn);
End;

procedure coremb;
begin
  for Demb:=1 to JVmax do
  begin
    for jr:=1 to jrmax do
    begin
      r[jr] := (0.2 + 0.6*jr/jrmax) * (Xmax-Xmin);

      { *Other versions for adjusting to the "linear" region * }
      { *           of the curve ln C(r) vs ln r           * }
      { r[jr] := (0.2 + 0.6*jr/jrmax) * (Xmax-Xmin) * sqrt(Demb); }
      { r[jr] := jr * sqrt(Demb) * (Xmax-Xmin) / (jrmax+1); }
      { r[jr] := exp(1.85 + ln(sqrt(Demb)) + jr*0.25/jrmax); }
      { r[jr] := exp(-6.0 + jr*0.5/jrmax); }

      Sum:=0.0; jmm:=jm-demb+1;
      for i:=1 to jmm do
        for j:=1 to jmm do
          begin
            Sum2:=0.0;
            for k:=1 to Demb do
              Sum2:=Sum2+(x[i+k-1]-x[j+k-1])*
                (x[i+k-1]-x[j+k-1]);
            if (r[jr]-sqrt(Sum2))>0.0 then
              {if ((j>i)or(j<i)) then} Sum:=Sum+1.0;
          end;
          CorCoef[jr] := Sum/jmm/jmm;
          writeln('  r=',r[jr]:8:4,' C(r)=' ,Corcoef[jr]:8:4,
            ' ln r=' ,Ln(r[jr]):7:3,
            ' ln C(r)=' ,Ln(Corcoef[jr]):7:3);
        end;
      for jr:=1 to jrmax do
      begin
        LnC[jr] := Ln(Corcoef[jr]);
        Lnr[jr] := Ln(r[jr]);
      end;
      for jr:=1 to jrmax-1 do
        Slope[jr] := (LnC[jr+1]-LnC[jr]) / (Lnr[jr+1]-Lnr[jr]);
      Slope[jrmax] := Slope[jrmax-1];

      k1:=1; k2:=jrmax; jr:=0;
      repeat jr:=jr+1;
      until Slope[jr]>dmin;
      k1:=jr; jr:=jrmax;
      repeat jr:=jr-1;
      until Slope[jr]>dmin;
      k2:=jr;
      { * Least Squares Criteria for all points between k1 and k2 * }
      { *           on Ln C(r)/Ln r curve           * }
      { * sigmamax is the upper limit of the overall deviation * }
    end;
  end;
end;

```

```

i1:=k1; i2:=k2;
repeat
  if Slope[i1]<Slope[i2] then i1:=i1+1 else i2:=i2-1;
  SumC:=0.0; Sumr:=0.0; SumCr:=0.0; Sumr2:=0.0; Sumz:=0.0;
  broi:=i2-i1+1;
  for jr:=i1 to i2 do
    begin
      SumC :=SumC + LnC[jr];
      Sumr :=Sumr + Lnr[jr];
      SumCr:=SumCr+ LnC[jr]*Lnr[jr];
      Sumr2:=Sumr2+ Lnr[jr]*Lnr[jr];
    end;
  Sysdim[demb] := (SumCr-SumC*Sumr/broi)/
    (Sumr2-Sumr*Sumr/broi);
  A[demb] := (SumC-Sysdim[demb]*Sumr)/broi;
  for jr:=i1 to i2 do
    begin
      Sumz:=Sumz + sqr(LnC[jr]-A[demb]-Sysdim[demb]*Lnr[jr]);
    end;
  sigma[demb] :=sqr(Sumz/broi);
until sigma[demb]<sigmamax;
writeln('Demb=',Demb:3,' Sysdim=',sysdim[demb]:8:4,
        ' a=',A[demb]:8:4,' sigma=', sigma[demb]:8:4,
        ' i1=',i1:3,' i2=',i2:3);
end;
end;

procedure XMinMax;
                                { * Minimum & Maximum X *}
begin
  Xmin:=x[1];
  Xmax:=x[1];
  for i:=1 to jm do
    begin
      if x[i]<Xmin then
        begin Xmin:=x[i]; i1:=i; end;
      if x[i]>Xmax then
        begin Xmax:=x[i]; i2:=i; end;
    end;
  writeln('Number of points ',jm:4,' Xmin=',
        Xmin:12:8,' i=',i1:4,' Xmax=',Xmax:12:8,' i=',i2:4);
end;

procedure autocor;
    { * Computation of the autocorrelation function *}
    { * After Schuster'86 *}
var average:real;
begin
  sum:=0.0;
  for j:=1 to jm do
    sum:=sum+x[j];
  average:=sum/jm;
  for i:=1 to jrmax do
    begin
      sum:=0.0;
      for j:=1 to jm-i do
        sum:=sum+(x[j]-average)*(x[j+i]-average);

```

```
A[i]:=sum/jm;  
writeln(i:4,A[i]:14:10);  
end;  
end;
```

```
                                { * Main Program *}
begin
{   dataHenonMap;                }
{   dataLogisticMap;            }
{   dataKaplanYorke;            }
{   dataRandom;                 }
{   dataArmsRace;               }
{   dataLorenz;                 }
{   datavietmonth;              }
  datavietweek;
{   dataMilBudget;              }
{   dataWWIcasualties;          }
  XMinMax;
{   autocor;                    }
  CorEmb;
  writeln;
  writeln('To return to Turbo Pascal press "Enter"');
  readln;

end.
```

## ENDNOTES

- <sup>1</sup> William L. Ditto and Louis M. Pecora, "Mastering Chaos," Scientific American August 1993: 78-84.
- <sup>2</sup> Major Eileen Bjorkman, et al, "Chaos Primer," Air Campaign Course 1993: Research Projects (Maxwell Air Force Base, Alabama: Air Command and Staff College, Academic Year 1994) 34-81.
- <sup>3</sup> Jess Stein, ed., The Random House College Dictionary (New York: Random House Inc., 1982) 224.
- <sup>4</sup> James Gleick, Chaos: Making a New Science (New York: Penguin Books, 1987) 306.
- <sup>5</sup> Gleick 20.
- <sup>6</sup> Gleick 28.
- <sup>7</sup> Gleick 99.
- <sup>8</sup> Gleick 102.
- <sup>9</sup> R. May and G. F. Oster, "Bifurcations and Dynamic Complexity in Simple Ecological Models," The American Naturalist Vol 110: 573-599.
- <sup>10</sup> Gleick 71.
- <sup>11</sup> Gleick 75.
- <sup>12</sup> Gleick 241.
- <sup>13</sup> Martinus M. Sarigul-Klijn, "Application of Chaos Methods to Helicopter Vibration Reduction Using Higher Harmonics" diss. Naval Postgraduate School, Monterey, California, March 1990.
- <sup>14</sup> Troy Shinbrot et al, "Using Small Perturbations to Control Chaos," Nature 3 June 1993, Vol 363: 411-415.
- <sup>15</sup> Gleick 139.
- <sup>16</sup> Jim Jubak, "Can Chaos Beat the Market," Worth March 1993: 66-70.
- <sup>17</sup> Gary Weiss, "Chaos Hits Wall Street--The Theory That Is," Business Week 2 November 1992: 138-140.
- <sup>18</sup> Diana Richards, "Is Strategic Decision Making Chaotic?" Behavioral Science 3 July 1990, Vol 35: 219-232.
- <sup>19</sup> Alan Beyerchen, "Clausewitz, Nonlinearity, and the Unpredictability of War," International Security Winter 1992/1993 Vol 17, No 3: 59-90.
- <sup>20</sup> J. A. Dewar, J. J. Gillogly and M. L. Juncosa, Non-Monotonicity, Chaos, and Combat Models (Santa Monica, California: RAND, 1991, report R-3995-RC).
- <sup>21</sup> Siegfried Grossmann Gottfried Mayer-Kress, "Chaos in the International Arms Race" Nature February 1989, Vol 337: 701-704.
- <sup>22</sup> Schuster 18.
- <sup>23</sup> In Eqn. 6,  $a=1.4$ ,  $b=0.3$ .
- <sup>24</sup> Grossmann 701-704.
- <sup>25</sup>  $x_{i+1} = 4bx_i(1-x_i)$ . The results are for  $b=1$ ,  $x_0 = 0.7$ , and  $x_0 = 0.70001$ .
- <sup>26</sup> J. M. T. Thompson and H. B. Stewart, Nonlinear Dynamics and Chaos: Geometrical Methods for Engineers and Scientists (New York: John Wiley and Sons, 1986) 1-11.
- <sup>27</sup> See Eqn. 5.
- <sup>28</sup> Heinz Georg Schuster, Deterministic Chaos: An Introduction (New York: VCH Publishers, 1989) 10-13.
- <sup>29</sup> Schuster 15.
- <sup>30</sup> Gleick 143.
- <sup>31</sup> Gleick 144.
- <sup>32</sup> F. Takens, "Detecting Strange Attractors in Turbulence," Lecture Notes in Mathematics Vol 898 (Springer Verlag, 1981): 22-30.

- <sup>33</sup>J. Wilkie, P. Brumer, J. P. Pique, Y. Chen, R. W. Field, and J. L. Kinsey, "Failure of the Fourier Transform of the Simulated-Emission Pumping Spectrum of Acetylene to Discern Chaotic Behavior," Physical Review Letters 28 Sep 1992, Vol 69, No 13: 2018-2019.
- <sup>34</sup>A. Wolf and J. A. Vestano, Intermediate Length Scale Effects in Lyapunov Exponent Estimation (Springer Series in Synergetics 39), ed. G. Mayer-Kress (New York: Springer, 1986) 94-99.
- <sup>35</sup>J. P. Eckmann and D. Ruelle, "Ergodic Theory of Chaos and Strange Attractors," Review of Modern Physics 1985, Vol 57.
- <sup>36</sup>G. Mayer-Kress, ed., Dimensions and Entropies in Chaotic Systems: Quantification of Complex Behavior (New York: Springer-Verlag, 1986) 100.
- <sup>37</sup>Mayer-Kress 102-103.
- <sup>38</sup>Mayer-Kress 102.
- <sup>39</sup>A fiducial trajectory is a reference trajectory.
- <sup>40</sup>Mayer-Kress 103-106.
- <sup>41</sup>Zeng 15-16.
- <sup>42</sup>Schuster 110.
- <sup>43</sup>J. D. Farmer, "Information Dimension and the Probabilistic Structure of Chaos," Z. Naturforsch 1982, Vol 37a: 1304.
- <sup>44</sup>C. E. Shannon and W. Weaver, The Mathematical Theory of Communication (Urbana, Illinois: University of Illinois Press, 1949).
- <sup>45</sup>Bing-Fei Wu, "Identification and Control of Chaotic Processes: the Kolmogorov-Sinai Entropy Approach," diss. University of Southern California, 1992: 1-111.
- <sup>46</sup>A. M. Fraser and H. L. Swinney, "Independent Coordinates for Strange Attractors from Mutual Information," Physics Review 1985, Vol 37a: 1134.
- <sup>47</sup>Xubin Zeng, "Chaos Theory and its Application in the Atmosphere," diss. Colorado State University, 1992: 18.
- <sup>48</sup>Zeng 18.
- <sup>49</sup>Zeng 17.
- <sup>50</sup>Zeng 16-17.
- <sup>51</sup>Mayer-Kress.
- <sup>52</sup>Catherine Marie Scipione, "Statistical Inference in Nonlinear Dynamical Systems," diss. The Ohio State University, 1992.
- <sup>53</sup>Reggie Brown, "Calculating Lyapunov Exponents for Short and/or Noisy Data Sets," Physical Review E June 1993, Vol 47, No 6: 3962-3969.
- <sup>54</sup>M. Damming and F. Mitschke, "Estimation of Lyapunov Exponents From Time Series: The Stochastic Case," Physics Letters A 19 July 1993, Vol 178: 385-394.
- <sup>55</sup>Matthew Lawrence Green, "Dependent Variables in Broad Band Time Series" Dissertation Abstracts International November 1992, Vol 53B, No 5: 2380: 4-125.
- <sup>56</sup>Klaus Fraedrich and Risheng Wang, "Estimating the Correlation Dimension of an Attractor from Noisy and Small Data Sets based on Re-embedding," Physica D 15 June 1993, Vol 65: 373-398.
- <sup>57</sup>Richards 219-232.
- <sup>58</sup>R. Ruelle, "Deterministic Chaos: The Science and the Fiction," Proceedings of the Society of London 1990 Vol 427A: 241-248.
- <sup>59</sup>Zeng 28.
- <sup>60</sup>Sarigul-Klijn, "Application."
- <sup>61</sup>Reggie Brown, "Calculating Lyapunov Exponents for Short and/or Noisy Data Sets," Physical Review E June 1993, Vol 47, No 6: 3962-3969.
- <sup>62</sup>Mayer-Kress.
- <sup>63</sup>John J. Mulhern, "Defense Investment Cycles 1948-1993: The Environment of Postwar Program Management," Defense Analysis April 1993, Vol 9, No 1: 11-29.

- <sup>64</sup>Budget of the United States Government: Fiscal Year 1993, Supplement (Washington: US Government Printing Office, February 1992).
- <sup>65</sup>Stephen L. McFarland and Wesley Phillips Newton, To Command the Sky: The Battle for Air Superiority Over Germany, 1942-1944 (Washington DC: Smithsonian Institution Press, 1991) 99.
- <sup>66</sup>Dewar.
- <sup>67</sup>Major Mike Bland, personal correspondence with the authors, March 1994, extracted from Air Force Wargaming Institute Compendium of Exercises, CADRE/WG, Maxwell Air Force Base, Alabama, February 1994.
- <sup>68</sup>McCrea.
- <sup>69</sup>George W. S. Kuhn, Ground Forces Battle Casualty Rate Patterns: The Empirical Evidence, Bethesda, Maryland: Logistics Management Institute, September 1989, Report FP703TR1.
- <sup>70</sup>See, for example, Wilkie.
- <sup>71</sup>Green 6.
- <sup>72</sup>Schuster.
- <sup>73</sup>P. Grassberger and I. Procaccia, "Measuring the Strangeness of Strange Attractors," Physica D 1983: 197. The map is  $x_{n+1} = 2x_n \pmod{i}$  and  $y_{n+1} = \alpha y_n + \cos 4\pi x_n$ , where  $\alpha = 0.2$ .
- <sup>74</sup>Sarigul-Klijn, personal correspondence with the authors, March 1994.
- <sup>75</sup>P. Grassberger and I. Procaccia, "On the Characterization of Strange Attractors," Physics Review Letters 1983, Vol 50.
- <sup>76</sup>Budget of the United States Government.
- <sup>77</sup>We adhere to the mathematical meaning of "periodic." The economists use a fuzzier definition (i.e. Mulhern).
- <sup>78</sup>Bjorkman.
- <sup>79</sup>Bjorkman, with  $x_{10} = 0.3$ ,  $y_{10} = 0.3$ ,  $k_{11} = k_{22} = 0.3$ ,  $k_{12} = k_{21} = 3$ , and  $x_s = y_s = 0.1$ .
- <sup>80</sup>See Eqn. 11.
- <sup>81</sup>Sarigul-Klijn, personal correspondence.
- <sup>82</sup>Michael M. McCrea, U.S. Navy, Marine Corps, and Air Force Fixed-wing Aircraft Losses and Damage in Southeast Asia (1962-1973 (U) (Arlington, Virginia: Office of Naval Research, August 1976, Center for Naval Analyses report CRC 305, downgraded to unclassified 8 Sep 89, Air University Library call number M-31914-22-U, No 305).
- <sup>83</sup>Least-mean-squares approximation, see paragraph II.C.2.
- <sup>84</sup>Sarigul-Klijn, personal correspondence.
- <sup>85</sup>Sarigul-Klijn, personal correspondence.
- <sup>86</sup>Beyerchen 59-90.
- <sup>87</sup>Gleick 251.
- <sup>88</sup>Edward N. Lorenz, "Large Scale Motions of the Atmosphere: Circulation," Advances in Earth Science, ed. P. M. Hurley (Cambridge, Massachusetts: The MIT Press, 1966) 95-109.
- <sup>89</sup>Diana Richards 219-232.
- <sup>90</sup>Sun Tzu, The Art of War, trans. Samuel B. Griffith (New York: Oxford University Press, 1961) 84.
- <sup>91</sup>Gleick 61-80.
- <sup>92</sup>M. Mitchel Waldrop, Complexity (Simon and Schuster, 1992) 273-274.
- <sup>93</sup>Jubak 70.
- <sup>94</sup>Pat A. Pentland, Center of Gravity Analysis and Chaos Theory, or How Societies Form, Function, and Fail (Maxwell Air Force Base, Alabama: School of Advanced Aerospace Studies, Air Command and Staff College, 1993), 16-26.
- <sup>95</sup>Shinbrot 417.
- <sup>96</sup>Col. John A. Warden III, USAF, The Air Campaign: Planning for Combat (Washington: Pergamon-Brassey's, 1989) 59-62.

- <sup>97</sup>Carl von Clausewitz, On War, ed. Anatol Rapoport (New York: Penguin Books Ltd., 1982) 243.
- <sup>98</sup>Captain B. H. Liddell Hart, The Real War: 1914-1918 (Boston: Little, Brown and Company, 1964) 61-63.
- <sup>99</sup>E. Luttwak, Strategy, the Logic of War and Peace (Cambridge: Harvard University Press, 1987) 27-31.
- <sup>100</sup>Warden 61-63.
- <sup>101</sup>Beyerchen 59-90.
- <sup>102</sup>The Random House Book of Mother Goose (New York: Random House Inc., 1986) 53.
- <sup>103</sup>Waldrop 40-41.
- <sup>104</sup>Waldrop 40.
- <sup>105</sup>The concept of concentrating on processes in warfare arose during a conversation with Lt Col Pentland. We believe that linking that notion to nonpredictability based on initial conditions is original.
- <sup>106</sup>Observe-Orient-Decide-Act.
- <sup>107</sup>John R. Boyd, A Discourse on Winning and Losing (Maxwell Air Force Base, Alabama: Air University Library, August 1987) unpublished manuscript, document #M-U 43947.
- <sup>108</sup>Hiroyuki Agawa, The Reluctant Admiral: Yamamoto and the Imperial Navy (New York: Kodansha International, 1979) 85-86.
- <sup>109</sup>Sun Tzu, 90.
- <sup>110</sup>Gleick 43-44.
- <sup>111</sup>G. Nicolis and I. Prigogine, Exploring Complexity (W. H. Freeman and Co., 1989) 31-35.