

INDUSTRIAL PREPAREDNESS MEASURES STUDY

PROCESS SYSTEM DEVELOPMENT for
PROPORTIONING and CONTROL of COMPOUNDED
DEHYDRATED COMPONENTS of SUBSISTENCE ITEMS

(Project 603 FY 60 QM)
Contract DA 11-027 QM(MSS)80490

Prepared For:

HEADQUARTERS, CHICAGO REGION
MILITARY SUBSISTENCE SUPPLY AGENCY

January 1962



QUARTERMASTER FOOD AND CONTAINER INSTITUTE FOR THE ARMED FORCES
QUARTERMASTER RESEARCH AND ENGINEERING COMMAND, U.S. ARMY
CHICAGO 9, ILLINOIS

Report Documentation Page

Form Approved
OMB No. 0704-0188

Public reporting burden for the collection of information is estimated to average 1 hour per response, including the time for reviewing instructions, searching existing data sources, gathering and maintaining the data needed, and completing and reviewing the collection of information. Send comments regarding this burden estimate or any other aspect of this collection of information, including suggestions for reducing this burden, to Washington Headquarters Services, Directorate for Information Operations and Reports, 1215 Jefferson Davis Highway, Suite 1204, Arlington VA 22202-4302. Respondents should be aware that notwithstanding any other provision of law, no person shall be subject to a penalty for failing to comply with a collection of information if it does not display a currently valid OMB control number.

1. REPORT DATE JAN 1962		2. REPORT TYPE		3. DATES COVERED 00-00-1962 to 00-00-1962	
4. TITLE AND SUBTITLE Process System Development for Proportioning and Control of Compounded Dehydrated Components of Subsistence Items				5a. CONTRACT NUMBER	
				5b. GRANT NUMBER	
				5c. PROGRAM ELEMENT NUMBER	
6. AUTHOR(S)				5d. PROJECT NUMBER	
				5e. TASK NUMBER	
				5f. WORK UNIT NUMBER	
7. PERFORMING ORGANIZATION NAME(S) AND ADDRESS(ES) Headquarters, Chicago Region, Military Subsistence Supply Agency, Chicago, IL				8. PERFORMING ORGANIZATION REPORT NUMBER	
9. SPONSORING/MONITORING AGENCY NAME(S) AND ADDRESS(ES)				10. SPONSOR/MONITOR'S ACRONYM(S)	
				11. SPONSOR/MONITOR'S REPORT NUMBER(S)	
12. DISTRIBUTION/AVAILABILITY STATEMENT Approved for public release; distribution unlimited					
13. SUPPLEMENTARY NOTES					
14. ABSTRACT					
15. SUBJECT TERMS					
16. SECURITY CLASSIFICATION OF:			17. LIMITATION OF ABSTRACT	18. NUMBER OF PAGES	19a. NAME OF RESPONSIBLE PERSON
a. REPORT unclassified	b. ABSTRACT unclassified	c. THIS PAGE unclassified			

1. The first part of the document discusses the importance of maintaining accurate records of all transactions. This is essential for ensuring the integrity of the financial system and for providing a clear audit trail.

2. The second part of the document outlines the various methods used to collect and analyze data. These methods include both qualitative and quantitative approaches, each with its own strengths and limitations.

3. The third part of the document describes the process of identifying and measuring the variables that are most relevant to the study. This involves a careful selection of indicators and a clear definition of the measurement scale.

4. The fourth part of the document discusses the importance of ensuring the reliability and validity of the data. This is achieved through a combination of rigorous data collection procedures and careful statistical analysis.

5. The fifth part of the document describes the process of interpreting the results of the study. This involves a careful examination of the data and a clear explanation of the findings. The final part of the document discusses the implications of the study and the need for further research in this area.

INDUSTRIAL PREPAREDNESS MEASURES STUDY

PROCESS SYSTEM DEVELOPMENT For
PROPORTIONING And CONTROL of COMPOUNDED
DEHYDRATED COMPONENTS of SUBSISTENCE ITEMS

(Project 603 FY 60 QM)

Contract DA 11-027 QM(MSS)80490

Prepared For:

HEADQUARTERS, CHICAGO REGION
MILITARY SUBSISTENCE SUPPLY AGENCY

JANUARY 1962

वर्ष १९५७ में भारत सरकार द्वारा प्रस्तावित योजनाओं का विवरण
जिनके अन्तर्गत ग्रामीण क्षेत्रों में कृषि, उद्योग, वाणिज्य, परिवहन, शिक्षा, स्वास्थ्य, आदि क्षेत्रों में विकास कार्य प्रारम्भ किया जायेगा।

योजनाओं के अन्तर्गत ग्रामीण क्षेत्रों में कृषि, उद्योग, वाणिज्य, परिवहन, शिक्षा, स्वास्थ्य, आदि क्षेत्रों में विकास कार्य प्रारम्भ किया जायेगा।

योजनाओं के अन्तर्गत ग्रामीण क्षेत्रों में कृषि, उद्योग, वाणिज्य, परिवहन, शिक्षा, स्वास्थ्य, आदि क्षेत्रों में विकास कार्य प्रारम्भ किया जायेगा।

योजनाओं के अन्तर्गत ग्रामीण क्षेत्रों में कृषि, उद्योग, वाणिज्य, परिवहन, शिक्षा, स्वास्थ्य, आदि क्षेत्रों में विकास कार्य प्रारम्भ किया जायेगा।

TABLE OF CONTENTS

FRONTISPIECE

SUMMARY

INTRODUCTION ----- 1

OBJECTIVE ----- 2

PROCEDURE ----- 3

RESULTS

Physical Characteristics of Materials ----- 6

Moisture Absorption Study ----- 8

Study of Soluble Pouches for Gravy Mix ----- 9

Study of Pelleting Technique for Gravy Mix -----12

Bacterial Contamination -----13

Materials Handling -----13

Volumetric Fillers -----15

Gravimetric Fillers -----18

Auger Filling -----19

Pouches -----20

Conveyors -----21

Container Controllers -----21

Gravy Mix System -----22

FACILITY RECOMMENDATION

Plant Layout -----28

Machines Specified -----29

Ingredient Handling Summary -----32

Future Work -----37

2023年12月

2023年12月

1. 2023年12月1日，收到A公司支付的货款10000元，存入银行。

2. 2023年12月5日，向B公司支付办公用品费500元，从银行存款中支付。

3. 2023年12月10日，计提本月折旧费2000元，计入管理费用。

4. 2023年12月15日，收到C公司支付的货款5000元，存入银行。

5. 2023年12月20日，向D公司支付货款8000元，从银行存款中支付。

6. 2023年12月25日，计提本月工资15000元，计入管理费用。

TABLE OF CONTENTS (Continued)

APPENDIX I

Plant Layout and Machine Modifications

APPENDIX II

Handling Means for Each Ingredient

APPENDIX III

Flow Quantities

APPENDIX IV

Illustrations

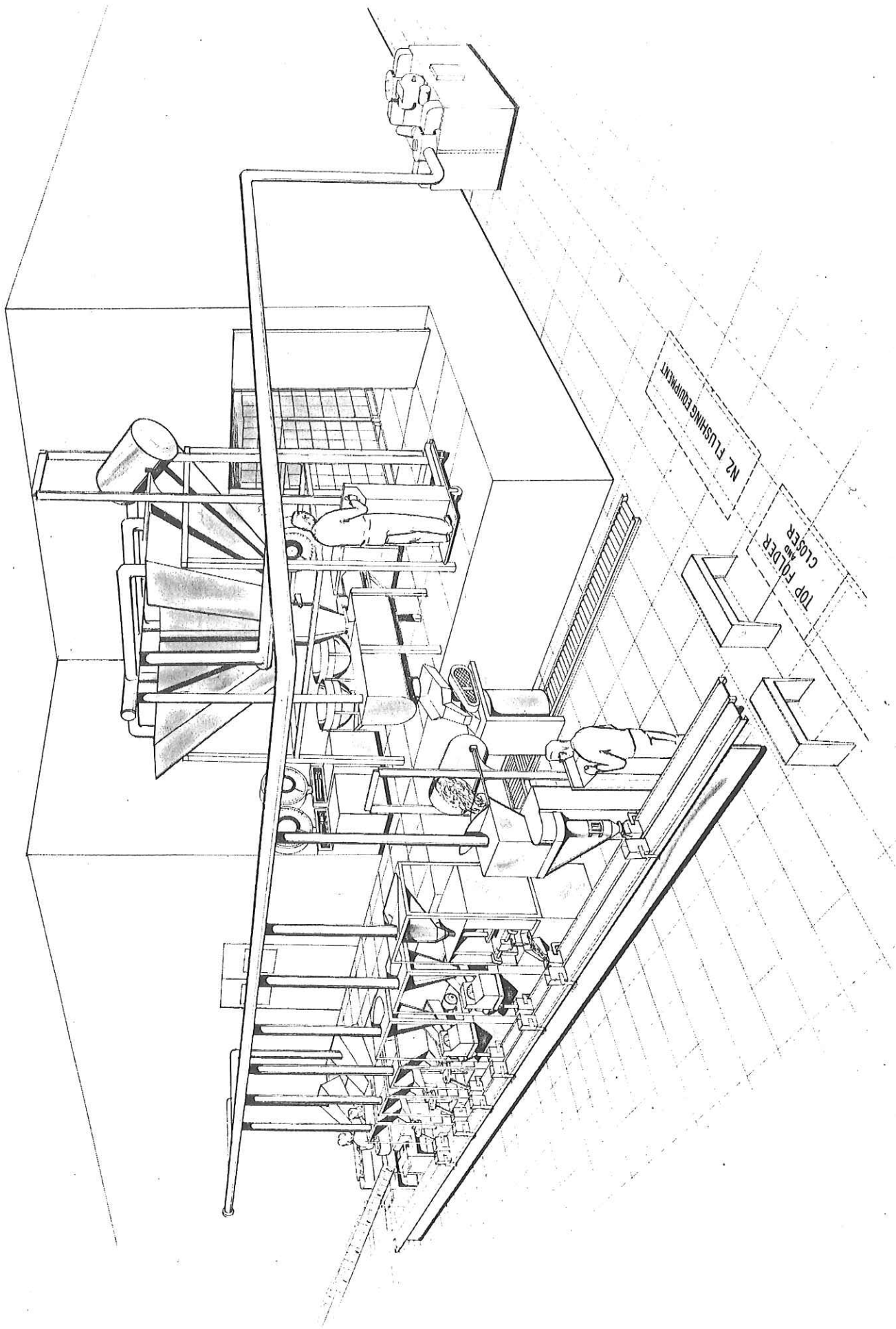

**DEHYDRATED MEALS
PREPARATION PLANT**

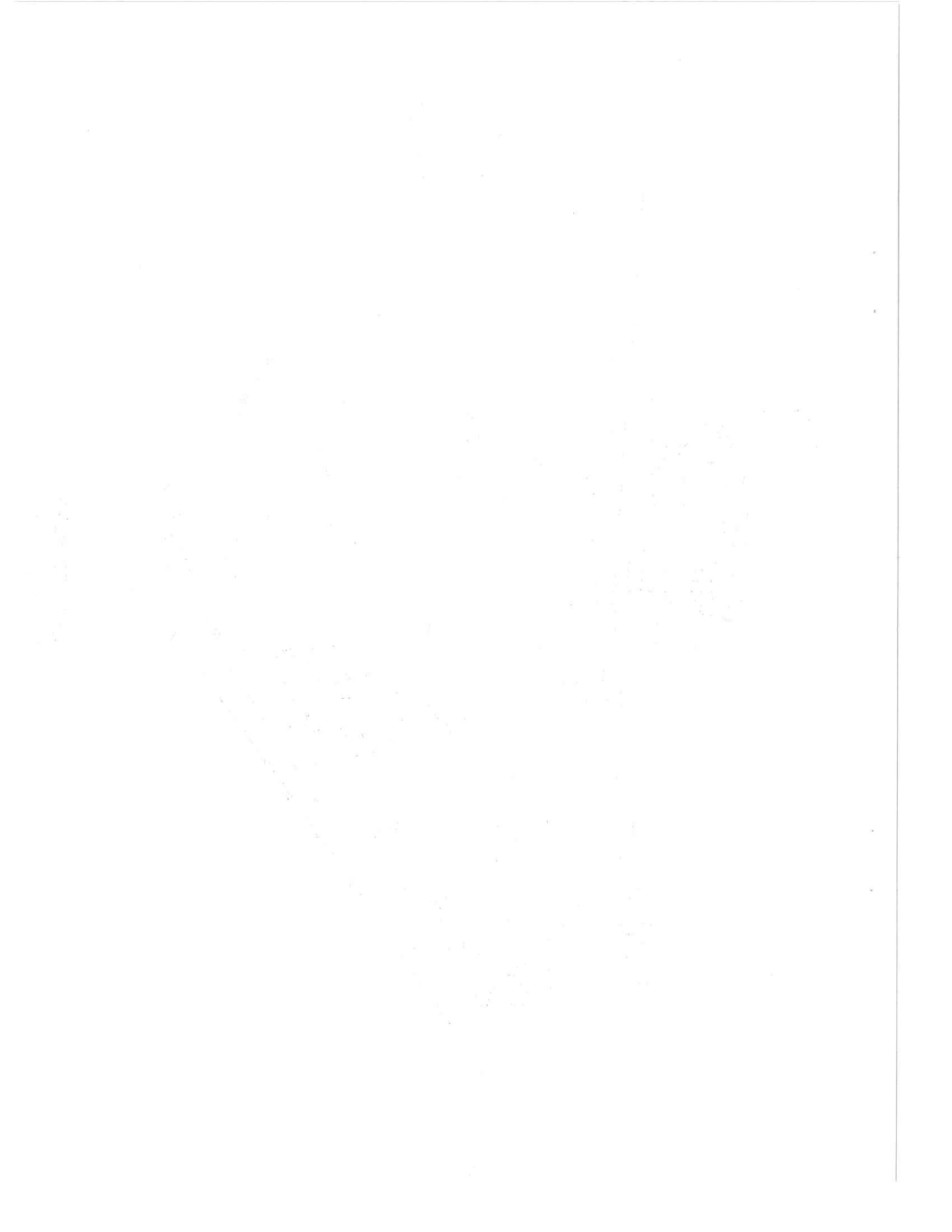

SUMMARY

In July, 1960, Central Engineering accepted a contract from the Military Subsistence Supply Agency to study the feasibility of constructing a plant to proportion and fill dehydrated meals into ration sized containers. This was an Industrial Preparedness Measure study, undertaken to insure that the techniques to construct such a facility are readily available should the necessity arise.

The nature of the foods to be processed was studied to establish the handling means, proportioning techniques and protective measures best suited to each particular ingredient of the meals.

Existing commercial operations, consultation with equipment manufacturers and product producers and results of experiments conducted in our laboratory, were all used to determine the most practical elements from which a complete facility could be built.

These elements were assembled into a proposal for a facility, which will be complete when unknowns pertaining to the meal container and to the methods of preparing and processing it are determined.

The following report contains the results of the study and a complete description of the plant facility proposed to answer the project objective.

The first part of the document discusses the importance of maintaining accurate records of all transactions. It emphasizes that every entry should be supported by a valid receipt or invoice. This not only helps in tracking expenses but also ensures compliance with tax regulations. The second part of the document provides a detailed breakdown of the company's financial performance over the last quarter. It includes a comparison of actual results against budgeted figures, highlighting areas where the company exceeded expectations and where it fell short. The third part of the document outlines the company's strategic goals for the upcoming year. It focuses on increasing market share, improving operational efficiency, and investing in research and development. The final part of the document provides a summary of the key findings and recommendations. It suggests that the company should continue to focus on its core strengths while also exploring new opportunities for growth. Overall, the document provides a comprehensive overview of the company's financial and operational status, as well as its future prospects.

INTRODUCTION

QMC has devoted considerable effort to the development of pre-cooked, dehydrated meals for serving the Armed Forces in the field. The high quality and exceptional flavor retention of the foods developed makes their acceptance by the Armed Forces virtually certain. Perhaps more important is the reduction in weight of these foods, due to the removal of water which is generally available everywhere for replacement. This reduction may amount to 80% of the original weight and will correspondingly reduce the handling problems. Therefore, it will become necessary at some future time, that an agency (Government or Civil) prepare facilities to proportion these foods into appropriate containers in sufficient quantities for continuous field use.

Enlightened planning requires that plans and specifications for such a facility be available in case a national emergency arises which would establish a large and urgent demand for these packaged meals.

To satisfy this requirement, industry was asked to submit bids covering the study of such a facility. FMC Corporation's bid was successful, and the following report is a summation of the work undertaken as a result of Contract DA 11-027QM(MSS)80490.

OBJECTIVE

The essential objective of the entire study was to formulate means to correctly proportion and fill into containers the necessary foods and ingredients for six specific menus furnished by the QMC. The study was to result in a proposal for a plant facility to carry out the stated purpose, adequately documented with proof that each item could be handled and proportioned in the exact manner indicated.

Each item was to be investigated in order to provide a basis for establishing sufficient protective measures during handling, such that the foods may be sealed into the containers under sanitary conditions and at moisture levels specified. To insure the standby or "preparedness" nature of the facility, we required that the proposal should use as little labor as possible to suit it for use during a national emergency.

PROCEDURE

Parameters: A number of principles were formulated to guide the design of a plant facility. These parameters and requirements were kept in mind throughout the design period to assure that the results would be acceptable to the Quartermaster Corps. These parameters were (in part) as follows:

1. The system designed should use as little manual labor as possible. Any unavoidable manual tasks should be light, in order to make use of the labor available during a national emergency.
2. An initial flow rate requirement was set at 200 lbs. an hour, with means for expansion provided.
3. At no point in the proportioning and filling system should the food products be exposed to contact with the atmosphere or other contaminants to a degree which would render them unfit for eventual human consumption.
4. Though six separate menus should be specifically provided for, the possibility of increasing the variety of menus should be considered.
5. Practical tolerances on filler performance, comparable to those current in industry, should be obtained.
6. New machinery development should be considered only if a diligent canvass of that which is commercially available does not uncover equipment suited to performing the task required.

Quantitative Material Examination: All the materials specifically enumerated by the contract were examined and measured to determine those physical characteristics which were judged to be of importance in handling or proportioning. The report contains a resume of this information in the form of a data sheet.

Machinery Survey: When the general nature of each task to be performed was known, a postal survey of commercially available machinery was undertaken to provide a library of pertinent catalog information from which specific machines for the final system could be chosen.

Quantitative Flow Analysis: An analysis of the quantities of materials to be handled was conducted to determine the physical requirements for possible items of machinery.

Commercial Precedents: In order to arrive at a proven, practical system, with the minimum of investigative effort, commercial precedents have been followed wherever applicable. This is particularly true in the case of the gravy mixes where the existing technology is well developed. Mixing means and cycles were investigated at several manufacturers' plants, notably, J. R. Stange Company, McCormick Schilling Company, Golden Grain Macaroni Company, Anchor Hocking Glass Company.

Water Soluble Gravy Mix Pouch: The use of a water soluble pouch in which to contain the gravy mixes was investigated. In theory, the water soluble container appears to be very satisfactory for those ingredients between which moisture migration is not expected. The environment for the pouches is a dry one; therefore, the bag will be quite stable when in its container. The whole container of material may simply be dumped into the reconstituting water without having to remove or tear open the pouch. Handling of the gravy would also be facilitated, since each portion could be prepared ahead of time and sealed into its own pouch container. These pouches may then be dispensed, as required, into the prime container. A summary of the investigation is included.

Pelleting of Gravy Mixes: A similar argument applies to the handling of gravy mixes in pellets, as in soluble pouches. These apparent advantages led to an investigation of pelleting as a desirable handling means for the gravy mixes. This study is also summarized in a following section.

Containers: The field of containers was not explored in this study since it is being treated under a separate project. Number 10 cans were used in this study for convenience and uniformity; however, the parameter of flexibility was so covered that no major problem should be encountered in adapting the process to containers of almost any likely type.

Materials Handling: Various means of handling each of the products were considered, from their receipt in standard moisture-proof drums, to the point of insertion into the container. Augers and vibrators were set up and tested in our laboratory for the appropriate products.

Moisture Protection: The most sensitive products were tested for their affinity for moisture, so that appropriate protective measures could be devised. Long term moisture pickup in a semi-sealed environment was investigated for those items which were to be stored in feeding hoppers for an extended time period.

Machinery Selection: After the questions of feeding and manner of proportioning had been answered, tentative machinery choices were made. These choices were tested on products which were deemed the most difficult of the group in which they appeared. For example, portion testing was conducted on chicken pieces, since they were judged to represent the most difficult product that we intended to proportion by gravimetric measurement.

In general, machines were chosen for their availability and capacity to handle the designated task. Though prices were taken into account, function was considered as the primary criteria for selection.

Accuracy Determination: We were able to complete a sufficient number of tests at our laboratory to answer the question of volumetric filling accuracy. To establish the accuracy of both auger and gravimetric filling, samples of the most difficult products were sent to the manufacturers' testing laboratories and their results are on file.

Machine Drawings: Machine modifications were held to the minimum possible, in order to ensure the availability of the system during an emergency. Those that were necessary were sketched to show the exact nature of the changes required.

Plant Layout: Several plant layouts were studied to determine the most desirable system. We attached particular importance to flexibility of rate, adaptability to other products and menus, convenience and efficiency of placement and product handling. The layout that seemed to offer the most advantages is the only one submitted, since a choice is logical only when no particular advantage is evident.

RESULTS

PHYSICAL CHARACTERISTICS OF MATERIALS

Data Sheet: A compilation of those physical characteristics which were considered to be of importance to a handling and proportioning study is given in Figure 1.

Flowability and Degree of Compaction: The only two items that may need explanation are flowability and compaction. No pertinent measure of flowability seems available; therefore, we rated the relative flowability only. To do this we prepared a number of 45 degree sloped funnels and cut various sizes of holes in the bottom measured in 32nds of an inch. The smallest size hole through which a one inch depth of material would flow freely was listed as the relative flowability.

To measure the degree of compaction we filled a 100 ml flask with the material being examined and observed the resulting volume of material after a given degree of vibration. This fraction is listed as a percentage of the original volume.

These tests permitted us to determine the most critical substances as far as flowability and packing are concerned.

Description: A written description of each of the products was prepared to aid both in contacts with industry to discover pertinent precedents and in specifications to machinery manufacturers.

PHYSICAL DATA

INGREDIENT	APPARENT BULK DENSITY GRAMS/LITER	MOISTURE (AS RECEIVED)	NATURE OF PRODUCT & APPROX. SIZE	RELATIVE FLOW-ABILITY	FRIABILITY	DUST PROBLEM (DEGREE)	COMMERCIAL PACKER	COHESIVE TENDENCY	ADHESIVE TENDENCY	DEGREE OF COMPACTION
Meat Balls	34.8	2.5	1 x 1/2 Oblate Spheroids	---	Medium	None	Courtland Labs. L.A.	None	None	---
Beef, Sliced III	27.0	2.8	Slices 3 x 3 x 1/2	---	High	Small	-----	None	None	---
Beef, Sliced I	---	2.0	Slices 4 x 3 x 1/8	---	Very High	Small	-----	None	None	---
Chicken Pieces	---	1.0	Chunks 1 x 1 x 3/8	---	High	Small	-----	None	None	---
Beef, Ground	26.5	1.7	Granular	38	Medium	None	Wilson & Co., Chicago	None	None	80%
Rice, Instant	---	---	---	---	Low	None	General Foods, Houston	None	None	---
Beans, Red	35.6	3.7	---	38	High	None	-----	None	None	93%
Carrots	25.0	3.8	Flake 1/2 x 5/8	38	Low	None	-----	Low	Low	80%
Peas	16.5	3.0	---	38	High	None	-----	Low	Low	90%
Potatoes	29.5	4.5	Flake 3/8 x 3/8 x 1/8	38	Low	None	-----	None	None	93%
Minced Onions	47.0	2.8	Flake 1/8 x 1/8 x 1/32	29	Medium	Yes, Small	-----	None	None	95%
Pepper, Red	30.0	11.0	Twisted Flake	38	Low	None	-----	None	None	90%
Starch	76.0	7.2	Powder	29	---	Yes	-----	Slight	None	80%
Sugar	89.0	---	Granular	15 easy flow	---	None	-----	None	None	100%
Salt (gravy)	117.0	.0c	Small Granules	15 easy flow	---	None	-----	None	None	89%
Salt (menu)	117.0	0	Small Granules	---	---	None	-----	None	None	---
Oleo Stock	---	---	Semi-solid	---	---	---	-----	Extreme	High	---
Lard	38.1	---	Flakes 1/2x1/4	29	---	---	-----	None at room temp	None at room temp	86%
Onion Powder	65.0	1.5	Powder	34	---	Yes	-----	Some	None	70%
Caramel Color	72.0	3.0	Powder	38	---	None	-----	High	None	70%
MSG	86.0	.0	Small Crystals	15 free flow	---	None	-----	None	None	100%
Pepper, Black	58.0	11.5	Small Flakes	29	---	Yes(danger)	-----	None	None	85%
Tomato Solids	43.5	3.5	Small Flakes	15	Low	None	Thornton Canning Co. Thornton, California	None	None	90%
Minced Onions	---	---	as before	---	Medium	as before	-----	None	None	---
Garlic Powder	48.2	6.3	Powder	38	---	Yes, High	-----	Small	Small	74%
Cloves, Ground	43.5	23.4	Powder	38	---	None	Imperial Trading Co. Chicago, Illinois	None	None	65%
Cinnamon	42.6	10.0	Powder	38	---	Yes, Medium	C. W. Antrim Richmond, Va.	Small	Small	65%
Nutmeg	48.0	9.6	Powder	15	---	Yes, Small	Gel. Spice Brooklyn, N.Y.	None	None	77%
Thyme	31.5	9.0	Powder	34	---	Yes, Extreme	Keams & Smith Chicago, Illinois	None	Some	66%
Chili Powder	66.0	11.0	Granular	34	---	None	-----	Small	None	90%
Poultry Seasoning	15.5	9.4	Fibre Powder	38	---	Yes, Medium	Holleb & Co. Chicago, Illinois	Minor	None	83%
Citric Acid	---	---	Powder	---	---	Small	-----	---	---	---
Beef & GB	65.9	5.0	Tacky Granule	34 cling	---	None	-----	High	High	87%
Chicken & GB	60.5	0.9	Tacky Granule	34	---	None	Thomas Lipton Hoboken, N.J.	High	High	80%
Flour	58.0	11.2	Powder	38	---	Yes, Medium	-----	Minor	None	70%

FIGURE 1

MOISTURE ABSORPTION STUDY

Sensitive Items: All of the food items were tested for their affinity for moisture. Initially, tests were conducted on traces of each material using the maximum exposure possible to the moisture laden atmosphere. These data allowed us to discover the particular products most sensitive to moisture pick-up.

Exposure Comparison: Curves of moisture pick-up versus time were run for totally exposed material and for material in a container. The rate of pick-up, as might be expected, is proportional to the exposed surface and, therefore, is much less for material in a container. Our particular concern was whether the rate of moisture pick-up was so fast that the material could not be transferred from storage to container without being damaged. The products must also remain in the open container for a period of time while on the conveyor belt, and proof of the safety of the products during this time was needed.

Available Time: The plotted curves vary for each of the products but it appears that about $\frac{1}{2}\%$ by weight of moisture will (on the average) be picked up by the product during the first hour of exposure to an atmosphere of 70% relative humidity.

Initial Moisture: It is unavoidable that moisture will be picked up if any exposure to a moist atmosphere occurs, whether this be immediately after the food has been dried or at the time it is packed. The producer is not likely to be able to prevent some exposure at the time he packs in bulk.

A short exposure at the packing plant is also difficult to avoid. Therefore, the product should be dried to a moisture level at least $\frac{1}{2}\%$ below the maximum acceptable, at the time it is sealed at the packing plant into its shipping container. This appears to be the only practical approach to the construction of a producing, and repacking system.

Atmosphere: The actual moisture entry during bulk packing will be an unknown variable. Therefore, the absolute minimum of moisture entry at repacking should be striven for and demands that the relative humidity not exceed 20%.

Dry Air Manifolding: In order to obviate the need for maintaining arid conditions throughout the working area with the subsequent unpleasant effects on personnel a manifold has been provided to conduct dehumidified air to every location where there is a possibility of the products contacting atmosphere.

Several means of lowering the relative humidity of the air may be used. Refrigeration is an effective means of obtaining dryness; however, an absorptive media type system is more convenient and is capable of producing a degree of dryness sufficient to protect the product from moisture attack. A typical drier is called out on layout 3461629.

Each of the filling machine hoppers is provided with a cover. Air, from the manifold that extends the length of the filling line, is piped through flexible hoses to each of the hoppers. The meat packing table hoppers are also purged with dry air which is allowed to pass over the product and out from under the plastic shelf continuously, thus, again minimizing contact between the meat and the possibly moisture-laden atmosphere. The gravy storage hoppers are also equipped for purging with dry air.

The major part of the dry air delivery is ducted to the storage room. Personnel working in this room will be exposed to these dry conditions. However, they will enter to store supplies and to withdraw supplies only. All time-consuming work, such as preparing and proportioning gravy, filling the product hoppers, proportioning meats, and all cleaning activities will be conducted under ambient conditions with only the product itself being washed by the dried air system.

STUDY OF SOLUBLE POUCHES FOR GRAVY MIX

Advantages: At the start of the proportioning study, we felt that it would be worthwhile to package all the gravy mix powders into pouches. Thus, it would be possible to make the gravy in large quantities for a limited time, place the mix in pouches and use the pouches from storage over an extended period. This procedure has been dropped because an appropriate pouch dispensing machine is not available. If all the gravies were to be in pouches, then a soluble pouch which would not have to be removed for separate re-constitution might have been a real convenience in the field. Our notes on the search for a suitable pouch material follow.

Summary: Four types of film were examined which may have present or future application for packaging dehydrated foods inside hermetically sealed containers. None of these films were found to be presently suited to the purposes of the project; that is, none of them satisfied all of the criteria set up for acceptability. Therefore, none of the films examined are recommended for our use.

Criteria for Acceptability: In order that we may safely and conveniently use a soluble packaging film for the purposes of the project the following criteria should be satisfied.

1. The film must be approved for human consumption, in the quantities necessary, by the FDA.
2. It must be a film that may be formed and sealed by presently available pouch making machinery with only the simplest modifications.
3. Strength and durability must be high enough to permit use with commercial handling techniques.
4. In solution, the film must have no detectable taste, odor, or objectionable consistency. No resulting scum or residue should be visible in the solution.

5. The film should go into solution with no apparent delay, 15 to 30 seconds being the maximum reasonable dissolving time. The solvent temperature (32 degrees to 212 degrees F.) should not appreciably affect the degree of solution.

Films Considered:

1. "Monosol" PVA film - 2 mil thick. (.002")
2. Dow Chemical "Metho-Cell" 1½ mil. (.0015")
3. Reynolds PVA film - 1½ mil. (.0015")
4. Kelco-Gel LV 5% solution - 15 mil. (.015")
5. United Carbide "Polyox". *

The films have been rated for their acceptability, or otherwise on the attached summation sheet.

A more detailed description is available in the laboratory notebook should it be desired.

Recommendations: It appears that a water soluble film, meeting all the criteria for gravy mixes, is not available at this time. Should PVA film be accepted for human consumption by the FDA, then it would appear to offer the most practical possibility for the future.

* This film was not tested. Literature indicates solubility "rate" was too slow.

LABORATORY NOTES ON THE EXAMINATION OF WATER
SOLUBLE FILMS FROM A GRAVY PACKAGING STANDPOINT

1. "Mono-Sol" PVA Film - 2 mil thick

Good quality heat seal. Under breaking stress break was at edge of weld.

Cold water solubility good, some debris not dissolved, scum left on surface. Agitation gives solution a "soapy" look.

Hot water solubility better, less debris and scum.

2. Dow Chemical "Metho-Cell" - 1½ mil

Firm, good quality seal.

Cold water solubility fair, very scummy surface to solution, little debris.

Hot water solubility poor. Large amount of debris and scum (not well dissolved).

3. Reynolds PVA Film - 1½ mil

Extremely flexible and tough film. Strong heat seal, hot water solubility excellent, no apparent scum or debris, and leaves small amount of residue.

No apparent difference in gravy solution to water only.

4. Kelco-Gel LV - 5% Solution

Film prepared by spreading on glass plate to a thickness of .030", and air dried. Sealing difficult - 5% solution used as an adhesive. Seal wrinkled and brittle. Film is brittle, easily torn - is hygroscopic. Solubility excellent - no scum or residue. No flavor when in solution.

5. Polyox - United Carbide

No film available for test.

PELLETING OF GRAVY MIXES

Advantages: The same arguments that apply to the periodic production and gradual use of pouches to contain the gravy mixes also apply to the compacting of the gravy into storable, dispensable pellets. Not only would the dispensing problem be simplified, but the volume requirements of the package would be reduced.

Size and Pressure: Pellets 3/4" inch diameter and weighing 5-7 grams, were formed at various gauge pressures. The pellets formed at 200 psi and 1500 psi appeared to have no density difference. If it is assumed that die wall friction is negligible, then pellet pressures from 5,680 psi to 42,600 psi were achieved.

Dispersal: The pellets formed at 5,680 psi and 42,600 psi required the same amount of time and agitation to become dispersed in a water base.

Breaking the pellets up by hand was required in all cases. The pellet is not adequately attacked and dispersed by water alone.

Binder: The use of a soluble binder was indicated. This binder would perform the same function as for pharmaceutical tablets; that is, their absorption of water would cause them to swell and thereby disintegrate the pellet.

Volatile Binder: Baking soda was added to the mix and a pellet was pressed. The resulting tablet disintegrated rapidly and spontaneously into a water solvent. However, the surface of the fluid was covered by a thick, soapy scum, which was quite permanent. The use of baking soda is therefore not considered satisfactory.

Technologists from our Canning Machinery Division suggested the use of Tragacanth, Karaya, or Karagenin to perform this function.

Tragacanth: Gravies for sliced beef and chili with beans were pelleted with tragacanth gum added. Pelleting pressures of 5000 to 6000 psi were used. The gum was added in the amount of 10 to 20%. Most of the pellets formed were strong and firm enough for our purposes, though the beef gravy pellets could not have been any weaker and still have been usable.

Rehydration: None of the pellets rehydrated readily. Pellets with tragacanth or without tragacanth were difficult to rehydrate. The presence of the tragacanth could not be detected by observation of the rehydration operation.

It appears that to be effective, the soluble binder in the pellet must be several times the magnitude of the non-soluble ingredients, which is deemed an impossible ratio for the given circumstances.

Summary: The reader will have already concluded, pellets that cannot be readily reconstituted have no practical value. Since no means for achieving reconstitution of the pellet were found, the use of this process does not appear to be feasible.

BACTERIAL CONTAMINATION

The problem of possible bacterial protection for our proposed filling facility was discussed with a Divisional Bacteriologist who reports that:

1. Bacteria need an environmental moisture of at least 12%. Even so, very few bacteria can flourish at this level and most need a level of 70 to 80%. A number of mold spores live at 30 to 40% and a much smaller number can multiply at the 12% level previously mentioned.
2. The approximate maximum moisture level expected in the dehydrated meals considered in this study is 4%. Although bacteria and molds do not multiply at 4% neither do they disappear. Therefore, the mold and bacterial level expected in the container upon opening will be that in the ingredients going in.
3. We must be sure that no pockets of moisture can occur where the local level can be as high as 100%. Otherwise local growth will be encouraged. W/O*emulsions, such as butter and oleomargarine, are particularly bad in this respect. Lard rarely has moisture pockets.
4. The conclusion is that we need not be concerned with problems of bacterial or mold activity and we need not consider any sterilization procedure subject to the following cautioning remarks:
 - a) The QM Corps must be sure that the ingredients it purchases are free of contamination. Military specifications on purchases must adequately control this.
 - b) We must maintain sanitary procedures in filling to prevent entry of contaminants.
 - c) We must mix fats adequately enough to prevent formation of local high moisture level pockets.

MATERIALS HANDLING

Vibrator: Chicken pieces, meat balls, ground beef, and several of the vegetables were tested for feeding on a vibrator pan and were found to respond satisfactorily. Several of the gravy base ingredients were tested but were found to feed poorly, particularly the fat-containing ingredients, such as the beef and chicken soup and gravy bases. Other means were investigated for handling these products.

It was found that the gate opening (between the edge of the product hopper and the bottom of the vibrator pan) was extremely critical and should be capable of rather careful adjustment. The opening must be found by experiment and varies for each product.

*Water and oil

Auger: The soup mixes, starch, and flour were all tested for adequacy of feeding by the auger method. It was found that all of these products need to be agitated within the hopper in order to prevent bridging above the auger flights. One method of overcoming bridging that proved satisfactory was to use an agitating disc. This disc was mounted on a shaft perpendicular to the auger axis and had gear-like teeth shaped to mesh with the auger. A variety of flukes may be added to the disc to increase the degree of agitation, their shape is not critical. The penetration of the disc teeth into the grooves between auger flights also serves to prevent the material being fed from rotating with the auger as a plug.

MEAT SLICE HANDLING

Handling Difficulty: It was early determined that the most difficult foods to handle, proportion, and fill were the sliced meats. Various means of handling were investigated, both with the supplier and at our laboratory.

Mechanization: The most practical means of mechanizing the proportioning of slices depends upon the availability of slices that are identical in weight and very closely the same in size and shape. A portion could then be dispensed by simply counting the exact number of slices required. We are informed by a supplier that cutting slices to the same weight is impractical, due to the difficulty of drying meat to the same density throughout (the natural variation in fat content complicates the problem). The waste involved in trimming to the same shape would also render the means undesirable, since prices would increase in proportion.

Slice Dispensing: After weighing some of the sliced beef as it was received at our laboratory, we have estimated that 99% of the slices by weight will fall between 17.78 and 7.22 grams. Therefore, for a 28 slice ration, 99% of the rations will fall between 322 and 378 grams, and the expected weight tolerance would be $\pm 8\%$, which is far too much for this expensive product. This approach does not take into account the number of broken slices that may be received.

Acceptable Mechanizing Method: An acceptable way to handle and proportion the slices mechanically would be to separate the whole slices from the fractional slices and fines. A machine would then have to be developed which would make the right selection of these whole slices, broken pieces, or fines, in order to reach the exact weight. In addition, the machine should be able to make the separation without breaking or in any way damaging the slices.

Study Result: After some study of the problem of designing such a machine, it was decided that for acceptable portion control, the task would have to be manually performed and a weighing table was designed to make the operation as efficient as possible. A very limited appraisal of the cost of the development of the necessary equipment versus the cost of the labor involved will suggest that mechanization is not economically feasible for the foreseeable future.

Weighing Tables: The weighing table constructed is shown in Figure 4 and Drawing #3461631. Its features are readily visible from these illustrations. Meat slices are fed into the hopper from the drums used for storage and transportation. These slices are pulled by hand onto the sorting tray where visual examination takes place. The operator brings small pieces and fines to the left of the filling spout to be used as "make-weight" pieces. Large whole slices are held on the right-hand side. The operator groups these pieces together into a quantity a little less than required; experience will quickly teach him the appropriate amount. He drops this bundle through the opening into a container. This container has previously been pulled from the rack, crossing the conveyor from his left and placed directly on the pan of the scale. The scale beam has also been preset to the required weight, and a counterweight appropriate for the container being used, placed on the rear scale pan. When the weight has been brought close to that required, small "make-weight" pieces and fines are pushed into the spout to make the weight exact. The container is then transferred toward the left to the packing area, where the slices may have to be arranged or pushed flat into the container to insure adequate room remains to seal the package. It is then placed on the appropriate conveyor line which transfers it to other filling stations.

It is estimated that about five containers a minute may be filled using this table. Several models were made before this particular one was chosen and changes should not be made before some operating experience is gained.

The large hopper minimizes the frequency of loading. Adequate protection for the product is achieved by piping dehumidified air into the product hopper and allowing it to flow through the meat and onto the sorting tray where it is retained by the plexiglass cover.

The cover is open only on the operator's side where the dried air is allowed to exit to the atmosphere.

The transparent hood protects the product from bacteria-carrying droplets, which may fall onto the product from the worker, and retains the meat in a dry atmosphere as long as possible.

Gloves should be worn by the operator to prevent moisture transfer as well as to maintain sanitary conditions.

The operator should close the hopper gate and finish loading the material on the sorting tray before leaving the station unattended for any reason.

VOLUMETRIC FILLERS

Accuracy: This type of filler is an extremely reliable type of machine and is intended for use with the vegetable products and the rice. A typical frequency distribution curve is attached showing the accuracy of fill that may be expected for rice. (Figure 3)

FREQUENCY DISTRIBUTION CURVE

WHITE PREGOOKED RICE
"WHIZ-PACKER" BENCH MODEL
VOLUMETRIC FILLER

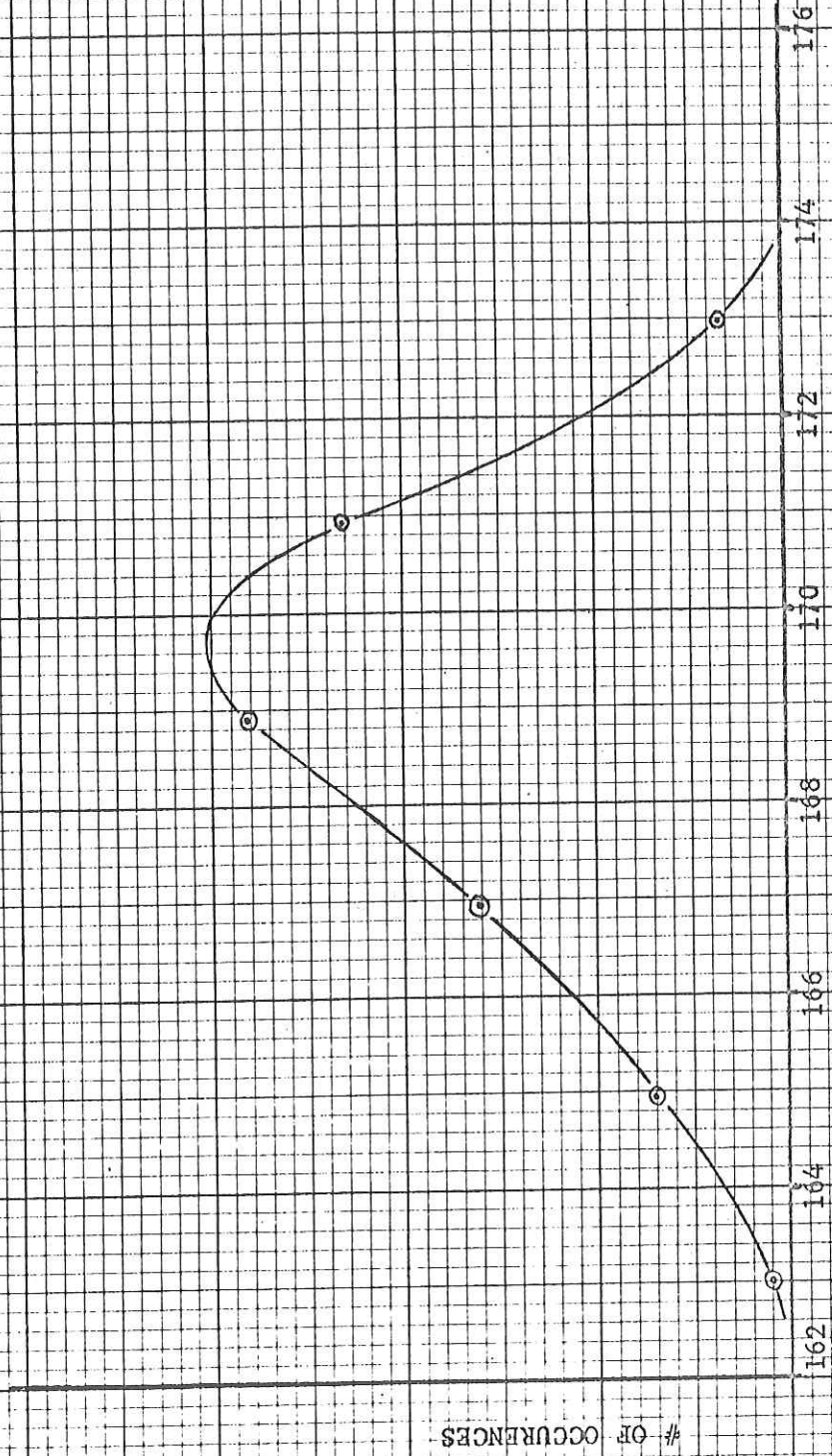

SAMPLE WEIGHT (GRAMS)

5/5/61

FIGURE 2

A large number of weighings for each of the products available were taken. The weighings were used to calculate an accuracy rating factor, named the coefficient of variation. This rating is calculated by equation:

$$\text{Coefficient} = \frac{\sigma}{\bar{x}} \quad (100\%)$$

where σ is the usual standard deviation and \bar{x} is the average weight. This coefficient has the value for each of the products tested as listed below:

<u>Material</u>	σ <u>Standard Deviation</u>	\bar{x} <u>Average Filling Weight</u>	<u>Coefficient of Variation</u>
Rice	1.06 grams	169.4 grams	0.62%
Beans	1.9 grams	168.1 grams	1.1%
Carrots	0.5 grams	27.08 grams	1.8%
Peas	0.75 grams	49.4 grams	1.5%

Diced potatoes will also be proportioned and filled volumetrically. It is expected that their coefficient of variation will be about that of the peas; that is, 1-1.5%. None were available at the time the test work was done.

The required measurements were carefully made and the above data may be used with confidence. This machine must be checked periodically, however, by weighing its output. This is most necessary when changing from one charge to another of the same product since density changes may occur which alter the weight output. Fortunately, the high degree to which the vegetables are dried, minimizes this shortcoming. Figure 4 indicates the equipment that was used to conduct weighing tests on the machine to provide data from which the accuracy was predicted.

Operation: The material may be brought to the machines in drums on the elevated weighing platform and loaded into the product hopper. Each hopper will be equipped with a lid and an inlet hose which will discharge dry air from the plant manifolding system. This discharge of dry air will purge all moisture from the air entrained during loading.

Construction: The filling machine will be modified to fill upon demand by attaching an electric clutch in place of the standard manual clutch.

A micro-switch will be attached to the rotating head to disengage the drive after each filling. This control system is detailed on Drawing #3462022 and allows the machine to assume automatic operation.

A hinging delivery chute will be added to the delivery tube to permit the machine to fill into either of the conveyor lines.

All modifications are called out on Drawing #3461632. Speeds up to 40 containers/minute are available with no apparent loss in accuracy.

The particular machine illustrated is a Frazier & Son Model H. The machine was chosen from other volumetric fillers because of its vibrating feed to the measuring head hopper. Dried products are sometimes fragile and the small head loads (while improving consistency) should reduce breakage during proportioning and filling.

GRAVIMETRIC FILLERS

Use: All the more expensive items are to be filled by weighing fillers since it is the most accurate proportioning method available. The filler chosen moves material from the product hopper to the weighing head on a vibrating tray. Vibration is an effective means of transport for dry materials. The tray has two modes of vibration, high speed and dribble speed, to improve accuracy.

Filling: Material to be filled is loaded directly into the product hopper of the machine. The hopper is equipped with a lid which must be closed after each filling. A hose is also attached to the top of the hopper to conduct dry air from the dry air manifolding system.

Products: The products to be proportioned on a weight basis are meat balls -- chicken pieces -- ground beef.

Any products of a similar nature may also be filled by this means. Should any of the products contain a large amount of fine material, a two-element vibrator pan should be provided as indicated later in this section of the report and on Drawing #3461710.

Cycle: The machine filling cycle is actuated by a signal from the micro-switch attached to the container control arm. The machine may be purchased wired for fully automatic operation. The container indicator switch is placed in the hopper dump circuit so that the cycle is interrupted if no container is in position to be filled. The release solenoid of the container controller is actuated by the dumping mechanism. An operating cycle, therefore, would be about as follows:

1. Container strikes switch on stop.
2. Scale hopper dumps a weighed amount of material into the container.
3. The hopper dump trips a switch, which actuates a solenoid to withdraw the stop and allow the container to proceed to the next station.
4. Machine feeder reloads scale hopper to be ready to fill the next container in line.

Modifications: The machine is used exactly as supplied by the manufacturers. It is purchased with the control panel mounted on the scale side of the machine for convenient insertion into the floor layout. An additional drop tube is provided, as shown on Drawing #3461632, in order that the machine may be used to fill into containers on either of the conveyor lines.

Accuracy: The manufacturer was provided with a sample of chicken pieces with which to run tests on the machine. Information received from him indicates a weighing accuracy of ± 4 grams at an operating speed of 10 weighings/minute for a total fill of 180 grams.

The materials to be dispensed by this machine are among the more expensive of those listed on the menus. The filling machine is also the most accurate in the line. A means exists for improving the accuracy of weight delivered to the containers, and depends upon the existence of an appropriate amount of fine material. If sufficient fines are present, they may be separated during the feeding process. These fines are fed by a separate vibrator with a separate control. The bulk feed is taken from the whole pieces; the dribble feed is taken from the fines. A modification of the weigher which will allow this method of filling is shown on Drawing #3461710. Its use will depend upon the price of the product (i.e. chicken pieces, ground beef, etc.) at the time the filling line is set up.

AUGER FILLING

Use: Non-free-flowing, powdered or granular materials are most effectively proportioned by an auger. It is important that the material be cohesive enough to hold firmly within the auger, otherwise uneven flow will result. The material to be filled should also be of uniform density, since the auger is a volumetric measuring device. Uniform grain size is also desirable to assist in achieving an accurate fill.

Products: The products to be filled will, in general, be gravy mixes. The weights to be filled are 1.5, 3.4, 3.0, 1.75, 1.50, and 5 ounces. Two of these amounts need to be filled into flexible pouches. Therefore, the pouch forming and filling machines will be fitted with an auger proportioning means.

Protective Devices: The materials which we intend to handle by the auger method are cohesive because they contain fats. These fats may be attacked by atmospheric oxygen; therefore, the use of N₂ as a flushing medium is indicated. Where the material is packed loosely in the container, this flushing takes place just before closure. When the material is filled into a polyethylene pouch, which may require subsequent sealing, it must first be flushed in bulk by a vacuum method, and later filled in an atmosphere of N₂. The appropriate machine attachments should be provided to accomplish this.

Accuracy: Auger filling is an accurate means of proportioning and is, in general, used throughout the packaging industry for appropriate products. Sample materials were forwarded to a manufacturer, and the following results were obtained:

<u>ITEM</u>	<u>AVERAGE WEIGHT</u>	<u>ONE STANDARD DEVIATION</u>	<u>COEFFICIENT OF VARIATION</u>
Beef Soup and Gravy Base	3 ozs.	.022	0.73%
Chicken Soup and Gravy Base	1.5 ozs.	.016	1.06%

Operation: As with all other fillers in the line, the machine must operate on demand. Material will be brought from the gravy mixing area in drums and placed in the hoppers of the machines. The hopper of the simple auger filler will then be flushed with dry air.

In the case of pouch fillers, actual filling into pouches will be done in an N₂ atmosphere to prevent the entrainment of O₂. The machine will be operated upon a signal generated by the container control device, and arrangements for any adaptation of wiring should be made with the manufacturer at the time of purchase.

POUCHES

Use: Two of the menus specified by the Quartermaster Corps require the use of a polyethylene pouch to contain the gravy mixes. These are the Sliced Beef with Brown Gravy and Sliced Beef Loaf with Tomato Gravy.

Purpose: At the time of rehydration, the gravy mix may be removed, prepared separately, and later added to the beef in gravy form. This insures that the powdered gravy mix will not interfere with the rehydration of the meat item.

Precautions: After the containers have been filled with material, they are subjected to a vacuum which is broken with N₂. If future menus require a sealed pouch, the pouch would normally be sealed at atmospheric pressure

thus becoming internally pressurized to the degree of the vacuum. Therefore, the quality of the seal and the material strength of the film should be sufficient to withstand the stresses imposed. Two mil film, sealed with a conventional impulse sealer, has been found to be adequate.

For the menus specified in our study only partially sealed pouches are required in which case the above precaution does not apply.

CONVEYORS

Twin conveyors have been used to conduct containers past the line of filling machines. The flexibility of the facility, the increased use of the machinery and the possible increase in total output all indicate the advantage of adding the second line.

An extension of this idea to three or more lines introduces difficulties in finding room to mount the stops which control the passage of containers past the fillers.

Several types of conveyors were considered, including intermittent chain drives and smooth surface continuously moving belts. Since the containers and the contents are all so light in weight, it was decided that it would be practical to allow the container to slide on the belt surface during each filling cycle. This permits the use of the reliable and generally inexpensive continuous belt conveyor.

The belt connections must be carefully made to prevent damage to the cartons. They must be smooth and flat, particularly on their upper surface.

Conveyor speeds will depend upon the rate of filling selected by the facility constructor, i.e. 10 containers/minute, 20 containers/minute, etc. For ten 4-inch long containers/minute, the belt speed should be about 10 ft/minute, in order to allow plenty of space between containers on the belt.

CONTAINER CONTROLLERS

The conveyor belt to be used moves continuously, whereas the containers must be held stationary at each of the filling stations.

The arrival of a container into position to be filled should be signalled to the filler, in order that its function can commence. The container should be held stationary throughout the filling cycle.

When the container has been filled, it should be released and allowed to continue to the next filling station. At the same time, the next succeeding container should be held until the stop can be closed after the filled one has been released. As soon as the filled container is clear, the stop may be released and another cycle allowed to begin.

The control device should be equipped with a safety switch to prevent the filling cycle from starting if containers are backed up on the belt to the point of the filler. This will prevent unnecessary jamming or loss of material.

A device to provide the functions mentioned is shown on Drawing #3461634. It consists of a stop bar to interrupt the passage of a container on the belt, linked to a holding bar adjusted to brake the container following the one being filled. The device is actuated by a solenoid and controlled by micro-switches at the proper locations.

For the volumetric filler, a cycle would be as follows:

1. Filler is ready, with clutch to rotating head disengaged, and controller on line in stop position.
2. Container strikes micro-switch on stop, and engages clutch of filler, allowing it to cycle through a single fill, which falls into the container.
3. After charge has been delivered, turret of filler (in its rotation) strikes a micro-switch, which actuates solenoid of controller, and causes stop to withdraw, simultaneously braking succeeding containers.
4. As stop is withdrawn, its micro-switch opens, halting rotation of turret.
5. Filled container, after release, strikes micro-switch a short distance (1.2 times container length) down the conveyor line, releasing solenoid and allowing stop to return to rest position.

The other fillers are all electrically operated and controlled, and may be wired in a similar manner to permit them to fill upon demand.

Two controllers will be required for each filler because of the dual conveyor lines. In the scheme illustrated, 14 will be required.

GRAVY MIX SYSTEM

GENERAL

Two possible general approaches for handling the proportioning of gravy were considered; they are:

1. Place the exact amount specified by the menu into each container as it progresses along the conveyor line.
2. Premix all the gravy ingredients into a blend, and proportion the required amounts of the blend into the container.

The first possibility was ruled impractical after it was discovered that one of the ingredients, namely, thyme, would have to be delivered in amounts as low as .00438 grams per container. This type of machinery is more suited to laboratory than industrial use.

Various methods of handling the premix type of gravy system that were considered are:

1. Handle all ingredients mechanically and automate the entire process.
2. Divide the ingredients into two groups, based on the quantity desired, and handle the trace ingredients by hand and the bulk ingredients mechanically.
3. Handle all ingredients manually.

Method #3 was discarded, due to the contract request for mechanization and the laborious nature of some of the handling tasks involved.

Method #1 was considered and was finally discarded, due to the complexity and resulting cost of the equipment. The price of a control system alone would have been about \$15,000 for the 24 to 25 items involved. A special type of feeder (vibrascrew) would also have been required because of the potent nature (and therefore, accurate measure requirement) of most of the trace ingredients. At \$1,000 each, this would have raised the parts cost to \$32,000, excluding installation. Therefore, it was decided to use Method #2.

Consideration was also given to the alternatives of batch mixing or continuous feeding and mixing.

Continuous feeding and subsequent mixing in an auger type of device seems to be more suited to the situation in which only a few ingredients are involved. Otherwise, a very low degree of equipment utilization will result. In the present case, a minimum of 12 feeders will be required with a usage of about 50%.

Another factor to be considered is that changes in the rate of delivery of any feeder will change the ingredient ratio of the gravy.

Some of the gravy mixes, particularly those in which fats are included, require a greater degree of mixing than those in which only granular ingredients are involved. Changes in a continuous mixing operation are more difficult to make than in a batch operation.

A fact to consider is that the six menus specifically assigned for this study represent a small fraction of the number which it will one day be necessary to prepare, and the construction of a fixed, inflexible line damages one purpose of this contract.

For these and other reasons, it was decided to use a batch operation for the gravy mixes.

INGREDIENT BREAKDOWN

The trace ingredients for the six menus considered are as follows:

Minced Onions	Cinnamon
Red Peppers	Caramel Color
Citric Acid	M S G
Poultry Seasoning	Black Pepper
Onion Powder	Nutmeg
Garlic Powder	Thyme
Cloves	

The bulk ingredients are as follows:

Starch	Chicken Soup and Gravy Base
Salt	Tomato Solids
Sugar	Chili Powder
Beef Soup and Gravy Base	

The fat ingredients which are liquefied are as follows:

Oleo Stock	Lard
------------	------

TRACE INGREDIENTS

Storage: The ingredients will be stored, unopened, in their original containers in the controlled atmosphere warehouse until required for processing. We anticipate the use of moisture-proof (asphalt barrier) fiberboard drums by the supplier. The light weight of these drums will ease the handling problem at the proposed facility.

Removal: At the start of a typical day's run the required items will be removed from storage and delivered to the gravy preparation area, where they will be opened and the required amounts removed. A vacuum chamber and N₂ flushing bottles should be available for replacing the atmosphere on partly used packages returned to storage.

Proportioning: The appropriate amounts of each ingredient will be weighed on the hand scales. As each item is weighed, it is transferred to the pan of a second scale. After a specified number of items have been weighed, the second scale may be checked to insure that no items have been missed. In some cases, as indicated, the presence of all the trace ingredients necessary to the mix may be checked with a single reading on the checking scale.

Loading the Mixer: An opening in the mixer will be provided through which the ingredients may be added to the rest of the mix. It will be necessary to open and close a lid during the operation.

Sequence: An important restriction should be noted; that is, the trace materials must be added at appropriate times during the mixing cycle. This timing is indicated in the later facility recommendations.

BULK INGREDIENTS

Storage: The hoppers situated above the bulk scale pan are used as a permanent storage facility for the bulk ingredients. These hoppers may be loaded as required by removing the sealing lid and dumping drums of material with the drum elevator. After materials have been added or removed, the atmosphere is changed to a dry one by opening a valve to the dry air manifold. N₂ is then used to purge specific materials of O₂. All hoppers (to eliminate loading errors) are provided with a purging inlet at the auger, but N₂ will be used only on those hoppers containing the following materials:

Beef Soup and Gravy Base
Chicken Soup and Gravy Base

Tomato Solids
Chili Powder

Purging takes place at the exit end of the auger delivery tube. The tube is provided with an external thread, onto which screws a cap, from which a rubber hose is attached to a manifold fed by an N₂ bottle. Valves are attached at the manifold to control the system.

Feeders: Each of the "V" hoppers is bottomed by an auger feeder. Each feeder is driven from a gearhead motor through a clutch. Holding down the appropriate control button engages this clutch to feed the specific ingredient desired. The hoppers and drives are illustrated on drawing #3461630. Iris valves are used to control the free flowing materials, salt and sugar.

Scale: Material is delivered by the augers to a suspended scale pan. The pan is connected to a readout dial in view of an operator standing at the control panel. The scale suspension and readout dial are all standard equipment at various manufacturers.

Controls: A control panel is located immediately below the scale readout dial. This panel contains a button for each of the auger drives; holding down a specific button feeds the desired ingredient. A chart opposite the row of control buttons indicates the contents of each of the hoppers. Each of the menus has a removable weight card, which may be placed in position opposite the list of ingredients to call out to the operator the weight of each required. The operator holds down a button and watches the scale readout dial. When the correct weight is reached, he relieves pressure on the button to stop feeding. The button may be jogged to deliver small amounts of material to the scale. Indicator lights may be used to aid the operator's memory of what has or has not been delivered. The iris valves may be controlled in much the same fashion.

FATS

Handling Means: In order to achieve adequate mixing, it was found that the fats would have to be added in a liquid form. No satisfactory means are available to convert the fats to a powder or granular consistency, which would be necessary to insure an adequate dispersion in the solid state.

Melting: Both the oleo and lard should be heated to 140 degrees F, preferably in a double-jacketed kettle. This type of heater removes the possibility of producing hot spots (often caused by local heating), and the production of off-flavors, due to the local scorching.

Proportioning and Transfer: The fats may be proportioned volumetrically by means of a measuring container. They may be drawn from the melting kettle into a graduated container to a predetermined level, carried to the mixer in the same container, and dumped by hand into the rest of the blend. Other means of achieving this end mechanically were investigated (such as the use of volumetric pumping devices), but were discarded due to the obvious difficulties of cleaning. The possibility of cooling within the delivery tubes also indicated the acceptance of a manual transfer method.

MIXING AND HANDLING

Type: The type of mixer was decided upon after consultation with the manufacturer and after some experiments at our laboratory. While the twin shell type of blender seemed adequate for some of the more granular mixes, and while its mixing action was gentle and nondestructive, it did not perform well on the fatty ingredients that we must often use. The shearing and breaking action of a blade type machine was found to be necessary, and it was therefore decided that a ribbon blender would be specified. This concurred with the manufacturers' recommendation for the type of material we propose to handle. Figure 5 shows the transparent tube that was built to enable us to observe the tumbling action of the twin-shell blender to judge its adequacy.

One factor we were not able to judge properly on a small scale was the possibility that the liquid fats added to the blend may cool and solidify before adequate dispersion is achieved. This possible problem may be solved by installing a steam-jacketed mixer to maintain the temperature of the ingredients at 140 degrees F until mixing is completed. A full scale test at the time of purchase at the manufacturers' plant should be insisted upon.

Procedure: The most adequate procedure for achieving a uniform blend appears to be:

1. Place free-flowing granular materials, such as sugar and salt, into the blender first.
2. Weigh out and add the trace ingredients and commence mixing.
3. After time for adequate dispersion, which may be determined by examining the blend at intervals to observe when it has reached a stable uniform color level, the fatty non-free flowing materials, such as Beef or Chicken Soup and Gravy Base, should be added.
4. After more mixing, any liquid ingredients should be added, and mixing continued.
5. Finally, the dry powders, such as starch, should be added to dry the blend to a manageable consistency.

This procedure is outlined for each specific menu in our recommendations, but the general plan should be followed for other gravy recipes as they are developed.

Milling: After mixing, the blend is passed through a hammer mill to insure that all lumps are broken down before proportioning is attempted. An auger may transfer a lump throughout its length and ruin the accuracy of delivery.

The mill should be fitted with $\frac{1}{2}$ " diameter screen perforations, in order that such items as the minced onions are not broken down into a powder. A screen with smaller perforations may be used if this type of ingredient is not present.

Handling: At this point in the cycle the ingredients have been combined into a specific blend. It may be necessary to change the recipe from one mix to the next, as the plant inventory indicates. Therefore, it is necessary that the cleaning effort be reduced to a minimum to make change-over rapid and convenient. For this reason, it was decided that the gravy mixes would be delivered to storage drums immediately after mixing, for the purposes of either storage or immediate transfer to the hopper of the filling machine. Augers or similar transfer devices were discarded after consultation with commercial packers running similar installations.

N₂ FLUSHING:

The proportioning and mixing operations so far described deprive the gravy mix of its protecting N₂ blanket. When the mix is filled directly into the prime container it will receive the same protection as the rest of the menu at the time of N₂ flushing of the master package and no further processing is required. However, a different course must be followed by mix that is to be returned to storage or placed in a polyethylene pouch. These drums of mix must be placed in a vacuum chamber and emptied of air; N₂ may then be admitted to replace this air and the drum removed and sealed. Mix to be filled into polyethylene pouches will be further protected by the N₂ atmosphere maintained in the machine.

PROPORTIONING AND FILLING:

The gravy mixes are dispensed as required by either the flexible pouch machine or the auger filler already described.

FACILITY RECOMMENDATION

LAYOUT

Sketches: Drawing #3461629 describes the machine and conveyor arrangement in complete detail. The frontispiece illustrates in sketch form, the layout described by the drawing. Areas have been left for the location of machinery which may be required to set up the containers and which will be required to close, vacuumize, N₂ flush, and seal them. Other areas for warehousing of the raw materials and storage of filled containers may be observed. The actual size of these areas may be determined when some logistical studies for the proposed facility have been made.

Packing Tables: Most of the reasons for the choice of the particular arrangement shown have been given. The meat slices were loaded and packed first, because the prime container is placed directly on the scales, and therefore, the minimum of initial weight variation is required. It is also necessary to arrange the slices in the container, in many instances, a task that is best accomplished when it is empty.

Container Feed: The area of container feeding has not been investigated, because it is likely that a carton set-up machine may eventually be the feeding means. Three separate inputs are necessary, and an arrangement to divert a single machine delivery into the three lines will need to be devised.

Loading Platform: An elevated filler loading platform has been used to simplify the loading problems, as far as possible. Supplies may be placed on this platform by lift-trucks operating in the dehumidified warehouse area. The containers may be opened on the platform at the machine, and hand-dumped into the filler hoppers. The light-weight characteristic of dehydrated foods will permit this dumping to be done with very little effort.

Gravy Mix Handling: The actual operations have already been described in general, and a detailed instruction follows. The operation has been placed at the end of the line so that powders filled onto materials already in the container may filter down between these other materials, and allow the total menu to be packed in the minimum possible container. A mobile drum lift has been specified that may be pushed from hopper to hopper, or from filler to filler, as required. A roller or "skate" conveyor has been provided to ease the handling of the drums of processed mix. The drum lift may be used to raise drums directly from the bed of rollers. Should it become necessary to return drums of processed mix to storage, the lift-truck will be available.

Fillers: All the fillers have modified exit spouts, which allow them to feed into either of the conveyor lines. Of the pair of stops at each filling station the stop used to control the filler must be the one located on the same line that the filler is feeding.

Checkweigher: No checkweigher appears in the line, because the possible variation in weight of each of the items (i.e., for chicken stew) adds up to more than the total weight of several of the components. Since a weigher would therefore only have a limited usefulness, it was eliminated. The

types of fillers chosen are all very reliable and will perform adequately if product is present and they are in good repair. Since the small expected staff of the plant will not permit continuous surveillance of each machine some device to monitor the machine's delivery to guard against malfunction will be required. This may take the form of a vane which is deflected by the flow of product to the container and is interlocked with the wiring of the container controller so that a missed delivery will halt container progress and signal an attendant.

Package Volume: The contract instructed us to consider filling only into a #10 can and we experienced no difficulty in placing any of the menus well within this container. However, we have become aware that a rectangular, smaller container is likely to be adopted and foresee occasional problems in containing all of some of the menus in the sample examined. Several means of packing have occurred to us including devices to automatically vibrate each container, but these schemes have not been examined at this time.

MACHINES SPECIFIED

Meat Weighing Table: The device is called out, in detail, on Drawing #3461631, and may be viewed on Figure 4. The estimated price is \$500, including scales, or \$1,000 total.

Volumetric Fillers: Three of these are necessary, and we have chosen a type made by M. R. Frazier and Son of Clifton, New Jersey, called the Model H machine. Drawing #3461632 calls out the modification to be made in the filler chute to allow delivery to either line. Drawing #3462022 indicates modifications required to allow the machines to fill upon demand. It may be noted that it is necessary to provide an electric clutch between the drive motor and the rotating turret. The price for the three machines has been estimated at \$3,600.

Gravimetric Filler: Model 610-NW-FM-11-30 has been recommended by the Exact Weight Scale Company of Columbus, Ohio. Filler spout modifications are called out on Drawing #3461632. No wiring changes are anticipated. A total price of \$4,000 for the two machines is estimated.

Pouch Former and Filler: Drawing #3461633 calls out a typical commercial machine. A number of other machines are available in this area, of about equal merit. The FMC Model 1000 single tube pouch machine is one of the most advanced machines now available and is recommended. The machine must be so wired that it will form fill and release a pouch upon demand, and should also be fitted with a chute designed to feed the pouch to either of the filling lines. Since the pouches specified in this study are not to be sealed, the transverse sealing bar must be of special construction that will permit a solid seal above the cut-off means and an intermittent seal below. A price of \$10,000 is estimated.

Auger Filler: FMC Model EG, volumetric cam filler, has been specified. Spout modifications are called out on Drawing #3461633. Estimated price (wired to fill on demand) is \$3,200.

Drum Lifts: Any commercial lift with a lift of 12 feet will be suitable. The lifts should be mounted on casters to allow them to be used for more than one hopper. Each lift may be purchased for \$350 - two are required.

Heating Kettles: These may be used exactly as supplied by the manufacturer. The temperature of the contents must be limited to 140 degrees F. We have specified Lee (Heavy Duty) Jacketed-type, with flush outlet, priced at \$250 each - two are required.

Scales: Three scales will be required as a minimum. It is useful to have extra scales in a plant where proportioning is the primary activity. Scales will also be necessary to check the outputs of each of the fillers, particularly the volumetric fillers. Therefore, it is desirable to allocate at least \$1500 for this purpose.

Bulk Hoppers: These hoppers will be constructed on the site by the builder. Our sketch #3461630 illustrates these hoppers, and gives the major dimensions from which the details may be developed. For maximum product protection these hoppers should be constructed of stainless steel. Although they are in a dry, oxygen-free environment when in use, the possibility of rusting during plant shut-down must be considered. The augers may be constructed from a similar material. Total price for the eight hopper assembly is estimated to be \$5,400.

Weighing Hopper and Suspension: The Toledo Scale Company has been contacted, and is able to supply a standard scale suspension and dial readout system that is adequate. This system has been called out on the sketch. An estimated price for the scale suspension and dial indicator with connective rods is \$1,500.

Mixer: Any type of ribbon mixer of the correct capacity will be suitable for the task. One is required that has a cover to retain dry air fed from the manifold as it may be dangerous to beat moist air into the mix. The cover must have an opening through which the overhead scale pan may dump. Another input opening with a closable lid must be provided for the entry of the trace ingredients and liquids. A duct for the dry air manifold must be provided. An end dump is most desirable, and we require a motor-driven gate, operated from the control panel. A machine by Paul O. Abbe Unit #4 is specified, and is priced at \$2200 for the model required.

Mill: The hammer-mill is not at all critical, and a number of manufacturers offer equally good machines. We have specified a model by Fitzpatrick and Company, the M44D at \$350.

Dehumidifier: As has been mentioned, several means exist for lowering the humidity of the air. An absorbent medium system seems to offer the advantages of reliability and cheap operating cost, plus competitive original investment cost. A unit manufactured by Lind-Aire of San Francisco, or Cargo Caire Engineering Company of New York City is suggested. Actual figures on the required capacity for the machine are not available, due to unknowns of geographical location, and area to be serviced. The Lind unit is priced at \$8,500 for the 4500 cfm model which will be sufficient for purging the machines and hoppers, but may or may not be adequate for the dry room depending upon its size.

Moisture Barrier: Any dry warehouse that is constructed should use techniques that will include a moisture barrier on all six sides. A usual means is to include silicate of soda in the concrete from which the building is constructed. No dehumidifying equipment will be satisfactory unless a positive vapor barrier is formed.

Conveyors: Approximately 50 feet of conveyor will be required (Drawing #3461629 gives the exact dimension) and will cost about \$3,000 total.

Container Controllers: Fourteen container stops will be required at an estimated total cost of \$3,500.

Total Price: The total price for the machinery installed in the proposed facility is therefore, \$48,950. This excludes the building and any accessory equipment not listed, such as compressors, lift trucks, etc. It also excludes all construction costs even when these costs are directly related to the machinery installation. Instrumentation has also not been included. Some form of continuous recorder with detectors monitoring plant humidity and temperature will undoubtedly be required.

Table I below summarizes the equipment costs reported above.

TABLE I
Summarized Equipment Estimate

Item	Price/Unit	Units	Total
Meat Packing Tables	500	2	1000
Volumetric Fillers	1200	3	3600
Gravimetric Fillers	2000	2	4000
Pouch Former & Filler	-	1	10,000
Auger Filler	-	1	3200
Drum Lifts	350	2	700
Heating Kettles	250	2	500
Scales	500	3	1500
Bulk Hoppers	-	-	5400
Weighing Hopper & Suspension	-	-	1500
Mixer	-	1	2200
Hammer-Mill	-	1	350
Dehumidifier	-	1	8500
Conveyors	60/ ft.	50 ft.	3000
Container Controllers	250	14	3500
			\$48,950

Flow Rates: The quantities shown in Appendix 3 are based upon a menu flow rate of 200 lbs./hour. If both lines are utilized the total output will be 400 lbs./hour (200 of each menu). The container rate for this flow quantity is about 3.4 per minute. Equipment selected will permit increasing container rate to 10 per minute resulting in an output of 590 lbs./hour/line or a total plant output of 1180 lbs./hour.

Labor: An estimate of the active labor force required to feed the machines and process the containers is 12. Support personnel at least equal to this number will be required for servicing, invoicing, etc.

INGREDIENT HANDLING SUMMARY

This section of the report will summarize the actual manner of material handling by menu groupings and should be read in conjunction with the second half of Appendix 3 which gives the amounts of each item to be dispensed into each container. Menu 1 will be described in some detail and the others will follow in a more abbreviated manner.

Before loading the machine hoppers, they should be flushed with dehumidified air. The conveyor lines will, of course, be started and power supplied to all machines.

The bulk hoppers above the gravy mixer should be properly cleaned, dried, flushed with dry air, and loaded with the appropriate ingredients.

It cannot be over-emphasized that all machine hoppers, mixer bowls, scale pans, containers, or any surface that may contact any of the foods, be thoroughly dry. Sanitary conditions are presumed.

Before making a production run make sure that the adjustable filler spouts are all directed to dispense into the proper line of containers on the dual belt.

Menu 1 - Meat Balls with Gravy

Meat Ball Storage: Meat balls should be held in controlled humidity storage in the containers in which they are received (preferably 50 gallon drums). The drums may be wheeled onto the elevated machine loading dock with two-wheeled hand carts and opened next to the filler hopper.

Filler: The filler to be used is the 610NW-FM-10-0 exact weight model or equivalent. The hopper may be loaded and the lid closed. Flushing is allowed to continue.

Weight: Several sample weighings should be taken to establish that the required quantity is being delivered. A group of containers of standardized weight would be a convenience in the operation.

Gravy Ingredient Storage: The bulk ingredients will be held in the hoppers above the mixing bowl and replenished from the warehouse as required. Trace ingredients may remain in the containers in which they are received.

Preparation Procedure: These steps should be followed in the mix preparation. Care should be taken due to the high fraction of liquid fats to be absorbed by the dry ingredients.

1. Open the salt delivery auger and extract the required amount from the hopper as indicated by the scale. Use the low delivery speed to add the last fraction to the scale pan. Dump the salt into the mixer.
2. Follow the same procedure to dispense the required amount of sugar to the mixer.

3. On the hand scales, weigh out caramel color, onion powder, MSG, and black pepper. Add all these ingredients to the mixer.
4. Mix until the color is uniform. Be sure that arid air is being delivered to the mixer, and that the cover is closed before mixing begins. Always use the low speed first to avoid loss of the trace ingredients through the formation of dust.
5. Use the heated kettles to liquefy the lard and oleo stock. A volume measuring flash is used to dispense the required amounts of the liquids from the kettles. Add the liquids to the mixer and mix again.
6. Again use the bulk feeding augers to measure out the required amount of starch, and add it to the mixer. Continue mixing only until a uniform mix has been achieved.
7. Pass the mix through the hammer-mill. Since no fragile ingredient is present in this mix use normal screening. Collect the mix in drums as shown on the plant sketch.

Dispensing: The gravy mix is lifted and dumped into the hopper of the FMC model EG2 auger filler. A standard commercial drum lift may be used for this. Several samples should be taken from the auger filler and weighed to insure delivery of the correct amounts. Adjustments to the filler should be made as indicated by reading the scale.

Containers: The containers will be loaded directly onto the filling line conveyor at a rate sufficient to insure the filler a reservoir of available containers on the belt.

N₂ Flushing and Sealing: Each container after filling must be properly flushed with N₂ by subjecting it to a vacuum that is broken by the inert gas. Sealing must follow immediately to prevent diffusion of this inert gas blanket into the atmosphere.

Restorage of Ingredients: After the necessary amounts of the required ingredients have been removed from the storage container, this container must be subjected to a vacuum and flushed with N₂ in the same manner as the menu containers. After flushing, the storage container should be resealed immediately, and the container returned to the storage area. This practice should be followed for all containers as there is little hope of preventing the entry of moisture bearing air into the container while the product is being removed.

Bulk Storage: The storage bins for fat containing ingredients should be recapped at the auger end after use and N₂ circulated throughout in the manner indicated in Drawing #3461630. Other augers should simply be recapped.

Cleaning Up: Dry cleaning practices should be used wherever possible inside the filling area. "Hosing down" must be avoided wherever possible. The plant personnel must be aware of the extreme hygroscopicity of the foods and judge their activities accordingly.

Menu 2 - Sliced Beef Loaf with Spiced Tomato Gravy

Containers: In this case the containers will not be loaded directly onto the conveyor lines but will be loaded onto the slides supplying containers to the hand packing stations.

Sliced Beef Loaf: The drums of product may be carried to the meat packing table on hand carts. Each of the hoppers may be loaded directly from the drum, which may then be vacuumized, N₂ flushed, and returned to storage.

Packing Table: Delivery of dried air to the hoppers of each table is particularly important, since no sealing of the hoppers is feasible. The operator may be required to wear gloves since the food passes directly to the consumer with no subsequent sterilization. It is also probable that the operators hands will suffer from the dry air if they are not protected. The scales on the packing table must first be compensated for the average tare weight of the package. Then the required weight may be set on the side and the operator will be ready to commence filling.

Gravy: The gravy mixing procedure will follow that detailed for the previous menu very closely. The steps, in brief, will be about as follows:

1. From the bulk bins, feed to the scale (separately) tomato powder, sugar, and salt. Note, from Appendix 3, that the total quantity of salt called out includes that listed in the given menu for both the gravy and the main ingredient list. Be sure to replace the auger caps at the end of each delivery cycle and turn on the N₂ purging valve for the particular hopper used.
2. Remove from storage, open, and weigh-out on the hand scales, the minced onions, black pepper, garlic powder, cloves, cinnamon, nutmeg, and thyme in accordance with the proportions of Appendix 3. Add these to the granular materials already in the blender and mix. Again using the precaution of starting on a low speed to avoid dusting.
3. Auger delivery from the bulk storage bins is used to dispense the beef soup and gravy base. Mix again.
4. Finally add the starch, again from the bulk bins, and mix to even dispersion.
5. Pass the mix through the hammermill fitted with screens having 1/2" diameter holes since this mixture contains fragile particles.

Dispensing of Gravy Mix: The gravy mix for this menu must be contained in a polyethylene bag before being placed in the final container. The drums of mix may be raised on the portable lift and dumped into the hopper of the pouch maker (e.g. a model 1000 FMC Pouch Maker). The pouch maker will have an auger feeder to fill the pouches and its delivery should be adjusted and checked by sampling to insure correct proportioning. Several pouches should then be made and filled to check the operator's choice of a pouch size. When the pouch former and filler is ready to function it should be connected to the container controller (as detailed in the machine description section) to form, fill, and drop the pouch upon demand. Make sure the N₂ flushing system in the filler is in operation in order to assure that only the inert atmosphere exists in the product. Since this menu calls for the use of an unsealed pouch for the gravy mix, the special cross-seal bar altered as described in machinery section should be installed.

Clean-up: Flushing, resealing, and restorage of ingredients will take place as previously detailed.

Menu 3 - Sliced Beef and Brown Gravy

The only real difference between the procedure for this Menu and Menu #2 concerns the gravy preparation which follows:

1. First, feed the salt by means of the auger from the overhead bulk hopper onto the scale. After delivery of the required amount, as indicated by the scale, dump into the mixer.
2. Add the trace ingredients in the correct amounts to the mixer. These are, caramel color, onion powder, MSG, black pepper, and citric acid. Use the two scale system previously described to check the multiple weighings involved. Run the mixer slowly then more rapidly, until color is uniform.
3. Liquefy oleo stock in one of the kettles, measure out volumetrically the required amount, and add it to mixer. Mix again.
4. Finally, the starch should be fed from the bulk hopper onto the scale pan to the correct amount, then dumped gradually into the mixer to dry the blend.

Dispensing: The mix will be delivered to the pouch machine to be prepared for insertion into its final containers as in Menu #2.

Menu 4 - Chicken and Rice

Containers: The containers will be loaded directly onto the conveyor line being used.

Loading: The chicken pieces in sealed containers may be hand-trucked from the arid air storage across the elevated loading dock to the gravimetric filler (model 610NW-FM-10-0) and loaded into the machine hopper. Secure the

hopper cover and commence delivery of dried air. Rice should be removed from storage and loaded into the hopper of the volumetric filler (Frazier Model H). Again open the air valve to allow dried air to be conducted to the hopper.

Weighing: Set both the fillers to deliver the desired weights of product by taking samples and making adjustments to the measuring mechanism.

Gravy: The chicken flavored soup and gravy base which is the only gravy ingredient in this menu should be fed from the overhead hopper through the hammer-mill to insure that it is well broken down before being placed in the auger filler. The hammer-mill screen perforations for this operation should not exceed 1/8".

Gravy Dispensing: Handling of the gravy through the dispensing operation follows the procedure detailed for Menu #1. The auger filler manufacturer will recommend a particular type of auger for use with fatty materials (such as this one) and the operator should always make sure that the correct auger is installed before attempting to adjust the quantity being dispensed.

Menu 5 - Chili with Beans

Ingredient Handling: Red beans, in their storage containers, may be hand-trucked to the hopper of the volumetric filler. Adjustment sleeves will be available to allow the filler to delivery any required volume within the capacity of the machine. Since the amount of beans required for this menu exceeds the capacity of the specified machine, two fillers must be utilized to attain the required quantity.

Ground beef will be handled by the gravimetric filler. If, upon examination, the ground beef is found to contain too many large lumps for good portion control, it will be necessary to pass the batch through the hammer-mill. A reasonably uniform particle size is required for acceptable weighing.

Gravy Mixing: This mix is particularly prone to caking due to the high moisture content of the chili powder combined with the hygroscopic nature of the tomato crystals. Therefore, if it is convenient to prepare the mix ahead of time, it should always be passed through the hammer-mill before loading it into the filling machine hopper, otherwise improper proportioning will occur.

The actual mixing sequence is about as follows:

1. Feed the salt and the tomato crystals from the overhead hopper to the scale and then into the mixer.
2. Add the single trace element - garlic powder - and commence mixing.
3. Draw the chili powder from the bulk hopper, and dump into the mixer. Mix until the color is uniform.

4. Repeat with the beef soup and gravy base, and mix until dispersion is complete.

Dispensing: The auger filler is used to dispense gravy mix portions into the containers.

Menu 6 - Chicken Stew

Ingredient Handling: Chicken pieces may be withdrawn from storage and loaded into the hopper of the gravimetric filler, the usual sampling procedure being followed to insure good portion control. Peas, potatoes and carrots, are to be dispensed by means of the volumetric fillers. Powdered products are not well handled by the volumetric fillers, therefore, the user should be sure that the potatoes are in flake, not powdered, form.

Gravy Mix:

1. Measure the required quantity of salt from the overhead hoppers and dump into the mixer.
2. Add the trace ingredients - poultry seasoning and MSG - from the hand scales and mix adequately.
3. Finally withdraw the chicken soup and gravy base from the overhead hopper. Measure on the scale pan and dump into the mixer. This will have to be done in two batches due to the limited capacity of the scale.
4. Complete the mixing operation, pass through the hammer-mill and into the transporting drum.

Dispensing: The auger filler will be used to dispense the required amount into the containers.

FUTURE WORK

Moisture Content: It will be of advantage to specify exactly the fraction of moisture that may be permitted in each particular menu. This will then indicate the degree of latitude that may be allowed the producer that will still result in an acceptable pack.

Ration Containers: Space, power, and other service requirements for the facility will depend upon the container handling means. These means may involve machinery to set up and seal boxes, unscramble and sterilize cans, or perform other yet undesignated tasks, and will need to be completely described before actual plant design can begin.

Complete Layout: The geographical location of the facility will have considerable influence on the warehousing requirements. A logistical study of the sources of supply and the amounts, destinations, and frequency of dispersement of the plants output should yield the information necessary.

Pilot Plant: Our study has resulted in what we consider a feasible means to prepare dehydrated meals into usable ration sizes. The product protection and method of handling we have suggested may prove to be conservative, or in spite of our efforts, may prove to be lacking in some detail. Only the examination of a pilot plant's output will give this information and suggest refinements. We believe the answers to the above questions added to the results of this report should allow a pilot plant to be fully designed and constructed adequate in both function and operation.

APPENDIX I
PLANT LAYOUT
AND
MACHINE MODIFICATIONS

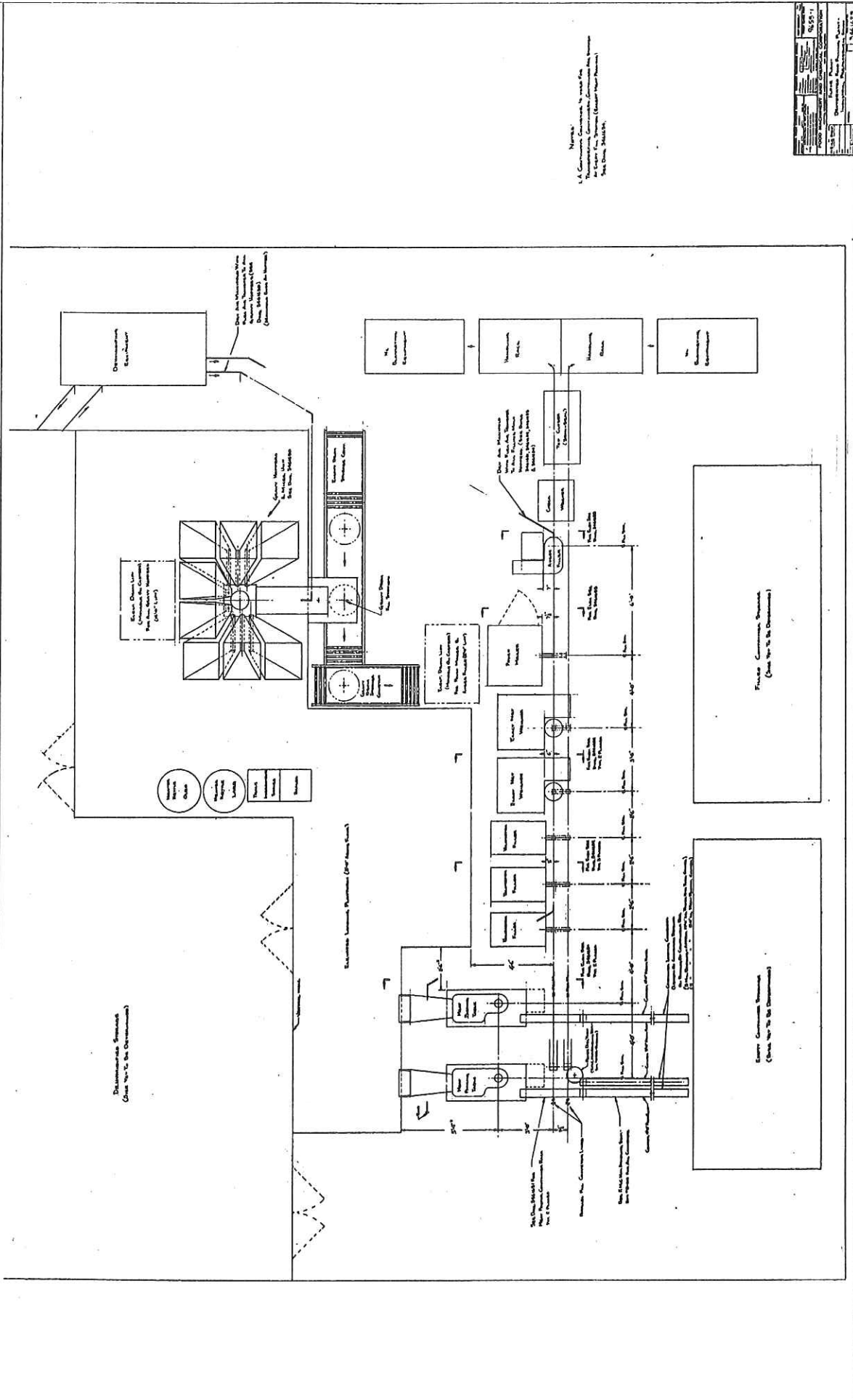

Name: _____
 U.S. Government Government Printing Office
 Washington, D.C. 20540
 (Check for Correct Rotation, Air Control, and Motor Operation)

Project No.	100-100000
Contract No.	100-100000
Order No.	100-100000
Revision No.	100-100000
Date	100-100000
Scale	100-100000
Author	100-100000
Checker	100-100000
Appr.	100-100000
Drawn	100-100000
Checked	100-100000
Project Engineer	100-100000
Project Manager	100-100000
Project Director	100-100000

FLOOR PLAN DEHYDRATED FOODS FILLING PLANT

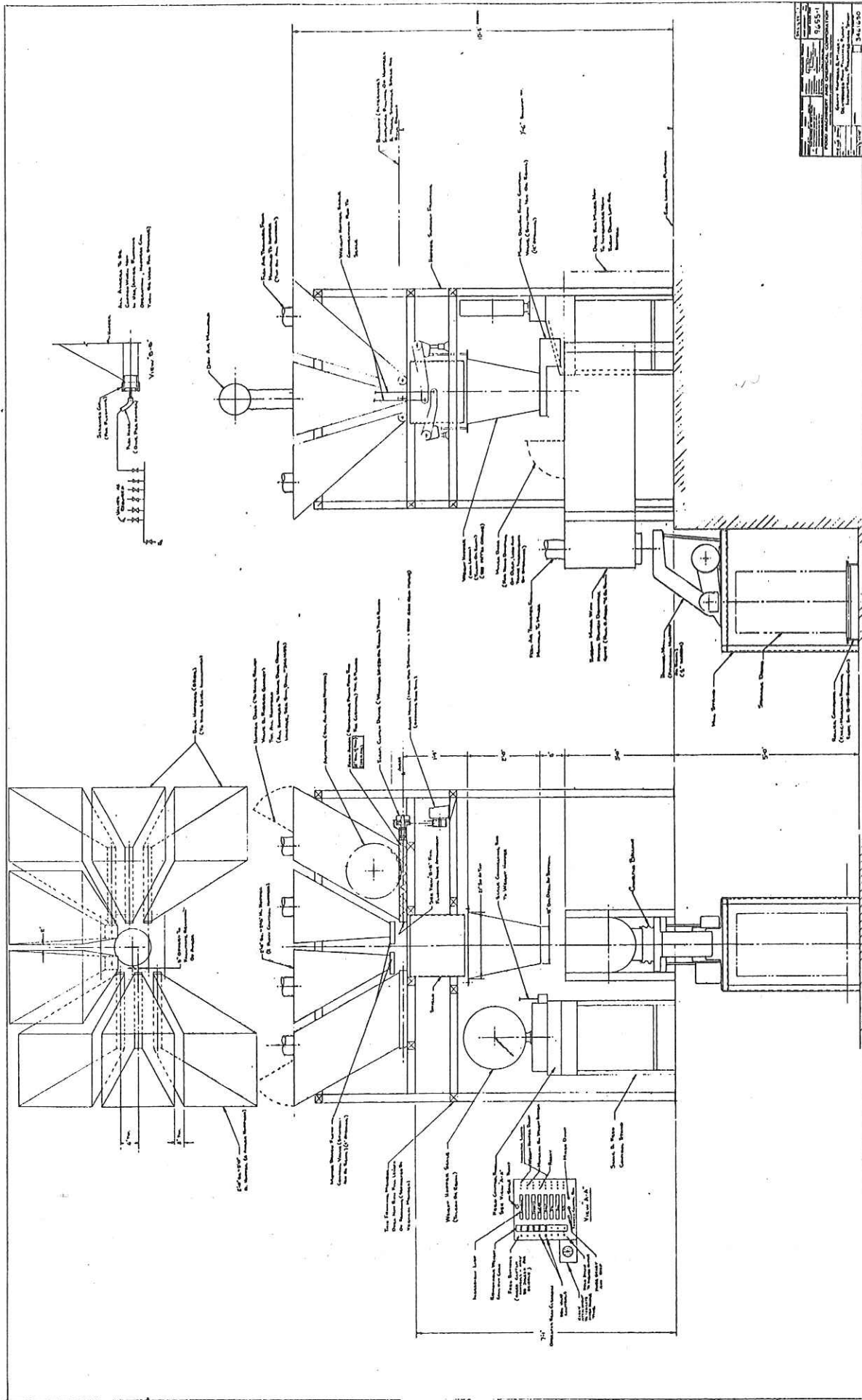

PROJECT NO.	34-11-100
DATE	10/15/50
BY	J. H. ...
CHECKED BY	...
APPROVED BY	...
DESIGNED BY	...
ENGINEER	...
SCALE	AS SHOWN
TITLE	GRAVY PREPARATION EQUIPMENT

GRAVY PREPARATION EQUIPMENT

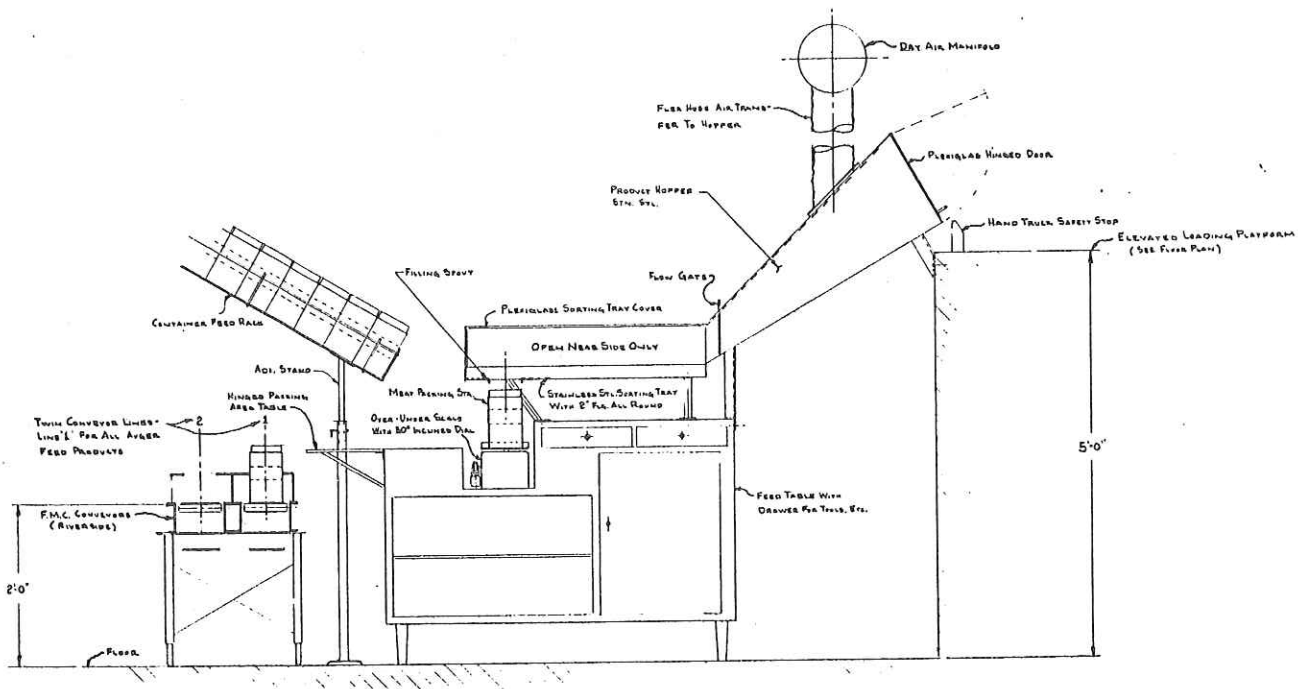
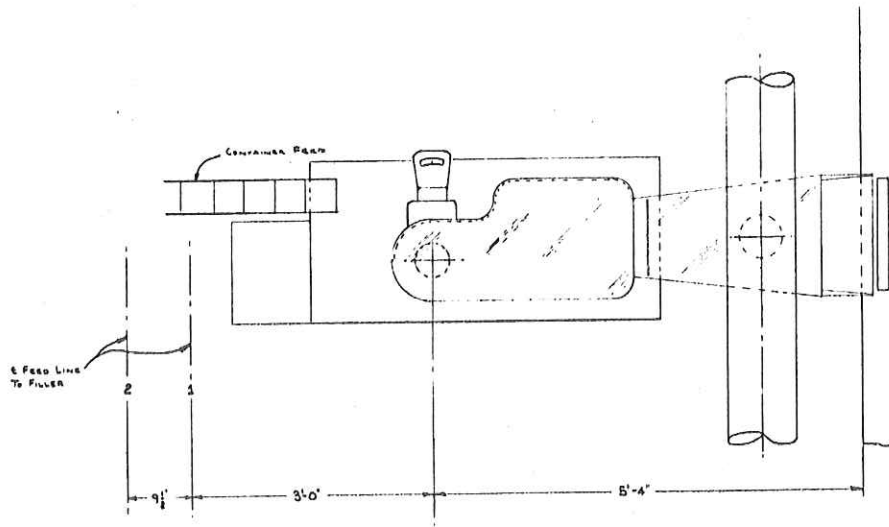

MEAT PROPORTIONING & PACKING TABLE

HISTORY SHEET DATE: 12/1/54 BY: J. H. B. S.	DESIGNER J. H. B. S.	36119
PROJECT MEAT PROPORTIONING TABLE	DRAWING NO. 9655-1	9655-1
FOOD MACHINERY AND CHEMICAL CORPORATION <small>DESIGN AND MANUFACTURING DIVISION</small>		
MEAT PROPORTIONING TABLE - DEHYDRATED FEED BLENDING PLANT - INDUSTRIAL PREPARATION STUDY		
3461631		3461631

13

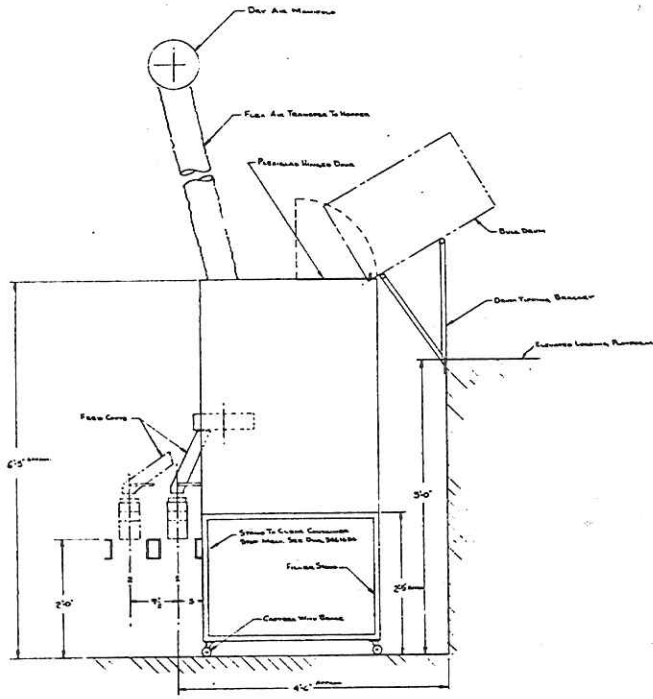

VOLUMETRIC FILLER (Frazier & Son, Mod. H'Whiz Packer Or Equal)
(Revisions To Std. Mach. Noted)

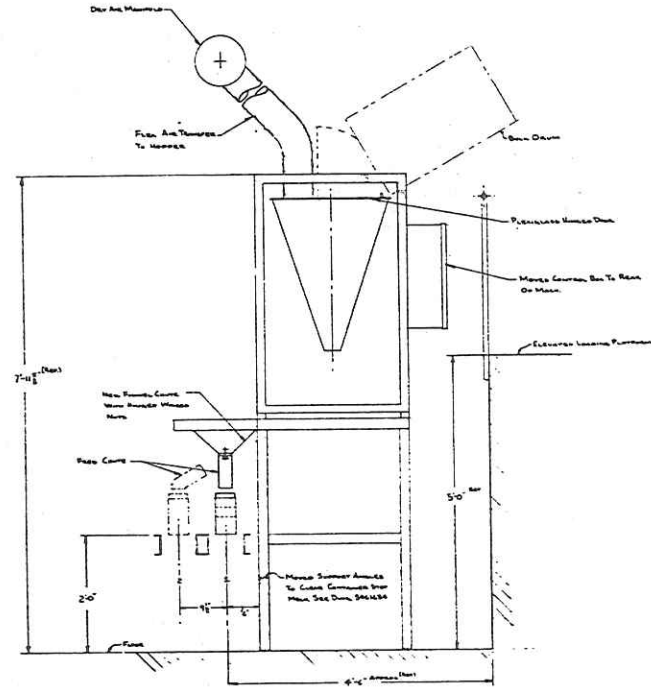

EXACT NET WEIGHER (Exact Weight Scale C^o # 610 NW-FM-10-0 Or Equal)
(Revisions To Std. Mach. Noted) (Also See Dwg. # 3461710)

DATE	DESIGNED BY	CHECKED BY	APPROVED BY
FOOD MACHINERY AND CHEMICAL CORPORATION			
2202 S.W. Voluntary Park & East Main, Portland, Oregon			
Incorporated in Oregon, U.S.A.			
No. 346155			

PRODUCT FILLERS

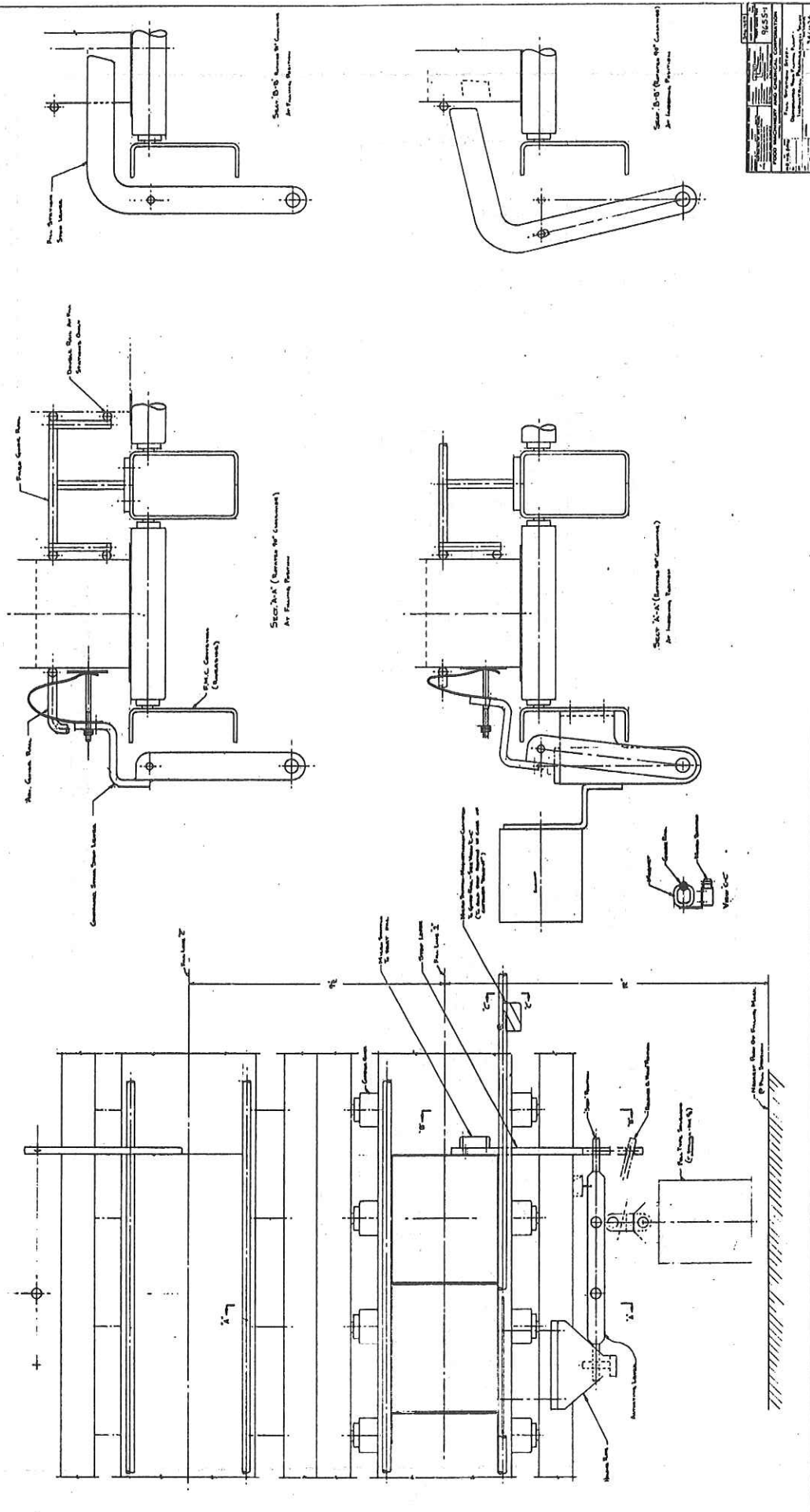

FILLING STATION STOP

PARTS LIST				
ITEM NO.	PART NUMBER	NO. REQD PER ASSEMBLY	DWS BY	DESCRIPTION

917

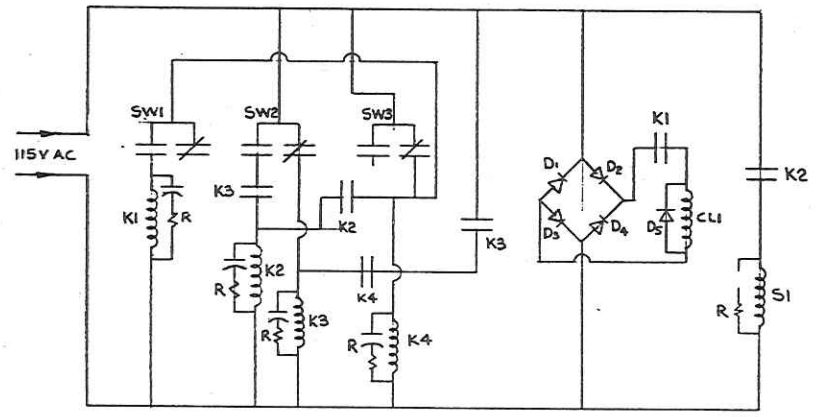
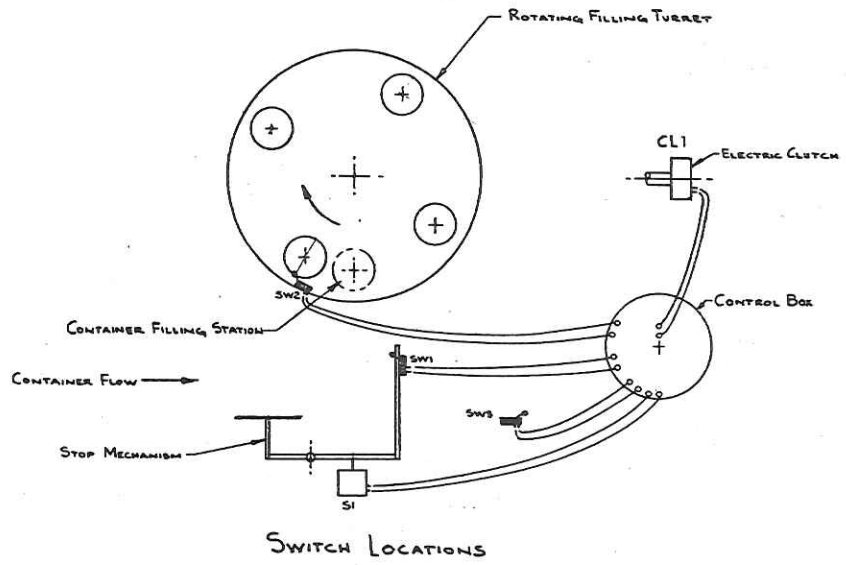

VOLUMETRIC FILLER CONTROL

TOLERANCES UNLESS OTHERWISE SPECIFIED: FRACTIONS ± ANGLES ± DECIMALS ± FEET ±		GEOMETRIC TOLERANCING SYMBOLS - Parallelism - Perpendicularity - Profile - Circularity - Roundness - Position - Concentricity - Symmetry		NEXT ASSEMBLY 9655
CHECKED BY: J.E. W. DRAWN BY: J.E. W. DATE: 6-24-61		INTERPRETATION: THIS DRAWING IS THE PROPERTY OF FOOD MACHINERY AND CHEMICAL CORPORATION CENTRAL ENGINEERING LABORATORIES SAN JOSE, CALIFORNIA		FIRST MADE FOR 9655
BY: EN. B. G. R. C. I. DATE: 6-24-61		WIRING DIAGRAM - FILL STA. - VOLUMETRIC FILLER DEHYDRATED FOOD FILLING PLANT - INDUSTRIAL PREPAREDNESS STUDY		DWS. C. PART NO. C 3462022
REV. NO. DATE BY APP.	REVISED DATE BY APP.	SCALE: NONE	MATERIAL	

PRINTED ON SHEET NO. 1000-12 CLEARPRINT PAPER-407

APPENDIX II
HANDLING MEANS
FOR
EACH INGREDIENT

HANDLING MEANS FOR EACH INGREDIENT

Ingredient	Portion			Portion Measurement and Dispenser	Feed System	Measuring Means	Basis
	Weight Ounces	Volume Qts.	Rate #/Min.				
Meat Balls	12.0	1.04	4	Exact Weight Company Automatic Scale #610 NW-FM-10-0	Vibrator Chute	Gravimetric	By test
Sliced Beef	12.0		4	Manual (Hand Operation) Scales by Exact Weight Over and under type 0-1 lb. Range	Manual	Hand Scales	In use by Campbell Soup Company and many other small packers.
Meat Loaf	12.0	1.33	4	Manual (Hand Operation) Scales as before	Manual	Hand Scales	Precedent as before
Chicken Pieces (1)	6.38	.686	3	Automatic Scale by	Vibrator Chute	Gravimetric	Tested by machine manufacturer
(2)	7.25	.780	4	Exact Weight Company #610 NW-FM-10-0			
Ground Beef	5.3	.602	3	Automatic Scale as previously specified	Vibrator Chute	Gravimetric	Vibratory feeding proved adequate by test
Instant Rice	6.0	.404	4	Frazier & Son-Model H	Hopper only	Volumetric	Laboratory test and commercial precedent
Peas	1.75	0.317	3	Frazier & Son-Model H	Vibrator Chute	Volumetric	Laboratory test
Potatoes	3.5	0.356	3	Frazier & Son-Model H	Vibrator	Volumetric	Laboratory test

HANDLING MEANS FOR EACH INGREDIENT

Ingredient	Portion			Portion Measurement and Dispenser	Feed System	Measuring Means	Basis
	Weight Ounces	Volume Qts.	Rate #/Min.				
Carrots	1.0	0.121	3	Frazier & Son-Model H	Vibrator Chute	Volumetric	Tested
Starch		↑ Varies for each batch-see quantity sheets ↓		↑ Measured on totalizing type batching scale ↓	Auger	↑ Gravimetric batching scale ↓	By test
Beef Soup & Gravy Base					Auger		In use by Schilling, Golden Grain, Stange, etc., and by test in our lab.
Tomato Solids					Auger		Tested
Chicken Soup					Auger		Similar to B.S. & G.B.
Chili Powder					Auger		Tested
Salt					Hopper Gate		Commercial practice for free flowing materials.
Sugar					Hopper Gate		Commercial practice for free flowing materials
All trace ingredients	See Quantity Sheets			Hand scales--ranges as required	Manual	Manual	
Gravy mixes	1.5 3.0 1.75 1.50 3.4 5.0	.054 .109 .064 .054 .124 .182	4 4 4 4 3 3	Flexible Pouch Machine Compak Model G or <i>exp. ar</i> Auger Filler FMC EG2 as required by menu	↑ Agitated Hopper ↓	↑ Auger ↓	Commercial packers (Schilling, Golden Grain, etc.) and by manufacturers recommendation.

67

INGREDIENT HANDLING DEVICE

(Continued)

Item	Machine	Specification	Manufacturer and Type	Commercial Users
Gravy Mixes	Blender	Ribbon Type ³ 200 lb--10 ft capacity	Paul O. Abbe Unit #4	Stange, Schilling
Fats (Oleo and Lard)	Liquifying Kettles	50 gal. capacity	Lee (Heavy duty) Jacketed Kettle with flush type outlet	Manufacturers Recom- mendation
Gravy Mixes	Hammermill	$\frac{1}{2}$ " dia. holes in screen + $\frac{1}{8}$ " screen	Fitzpatric Co., Model M44D	Stange
Gravy Mixes	Scales	Overhead suspended hopper type	Toledo Scale Co.	_____

The following information is being furnished to you for your information and use only. It is not to be distributed outside your organization. This information is being furnished to you for your information and use only. It is not to be distributed outside your organization. This information is being furnished to you for your information and use only. It is not to be distributed outside your organization.

SECRET

APPENDIX III
FLOW QUANTITIES

SECRET

QUANTITIES

The following quantities are for six men rations only. Simple multiplying factors may be used to change to any other size of ration.

It is probable that a 25 man ration may simply be 4-6 man rations overwrapped by a larger container. If the exact proportions are necessary the quantities may be converted to 6½ man sizes without sacrificing the advantages of having a uniform basic container.

The two filling lines may only be used together when the menus to be prepared require different combinations of filling machines.

To satisfy this requirement the six menus have been arranged into the following order:

First day:	Chili and Beans Beef Loaf and Tomato Gravy
Second day:	Sliced Beef and Brown Gravy Chicken Stew
Third day:	Meat Balls and Gravy Chicken and Rice

MEAT BALLS WITH GRAVY

	<u>6-man</u>	<u>25-man</u>
Meat Balls, Cooked, Dehydrated	12.0 oz.	50.0 oz.
Brown gravy*	1.5	6.25

*Gravy mix:

Percent by wt.

Starch, Instant	38.1
Caramel color	1.9
Oleo stock	15.24
Lard Flakes	3.80
Sugar	19.05
Salt	18.10
Onion powder	3.05
M S G	.59
Black pepper, Ground	.17

All ingredients to be nitrogen packaged together in one container.

MENU #2

SLICED BEEF LOAF WITH SPICED TOMATO GRAVY

	<u>6-man</u>	<u>25-man</u>
Beef, Cooked, Sliced, Dehy., Type III	12.00 oz.	50.00 oz.
Salt	0.25	1.00
Gravy Mix*	3.00	12.50

Percent by wt.

Tomato powder (salt free basis)	42.3
Starch, Instant	20.0
Beef Soup and Gravy Base	15.0
Sugar	10.1
Minced Onions	7.0
Black Pepper, Ground	.45
Garlic powder	.10
Cloves	.10
Cinnamon	.10
Nutmeg	.10
Thyme	.05
Salt	4.70

Gravy to be packaged in polyethylene bag. The bag to be placed in container with other components. Nitrogen packaged.

SLICED BEEF AND BROWN GRAVY

Beef, Cooked, Sliced, Dehy	<u>6-man</u>	<u>25-man</u>
Gravy mix*	12.0 oz.	50.0 oz.
	1.75	7.25

*Gravy mix

Percent by wt.

Starch, Instant	39.36
Caramel color	1.67
Onion Powder	4.90
Salt	31.97
M S G	3.90
Black Pepper, Ground	.50
Oleo Stock	17.20
Citric acid	.50

Gravy to be packaged in polyethylene bag. The bag to be placed in container with other components. Nitrogen packaged.

MENU #4

CHICKEN AND RICE

Chicken Pieces, Precooked, Dehy.	<u>6-man</u>	<u>25-man</u>
Minute Rice	7.25 oz.	31.25 oz.
Chicken Flavored Soup and Gravy Base	6.00	25.00
	1.50	6.25

All ingredients to be nitrogen packaged together.

CHILI WITH BEANS

	<u>6-man</u>	<u>25-man</u>
Beef, Ground, Precooked, Dehy.	5.3 oz.	22.0 oz.
Beans, Red, Cooked, Dehy.	12.5	52.0
Seasoning mix*	3.4	14.0

*Seasoning Mix

	<u>Percent by wt.</u>
Tomato powder (salt free basis)	41.16
Beef Soup and Gravy Base	25.12
Chili Powder	18.82
Salt	14.71
Garlic Powder	.20

All ingredients to be nitrogen packaged together.

MENU #6

CHICKEN STEW

	<u>6-man</u>	<u>25-man</u>
Chicken Pieces, Precooked, Dehy.	6.38 oz.	26.5 oz.
Potatoes, white, cooked, dehy.	3.50	14.6
Peas, green, cooked, dehy.	1.75	7.3
Carrots, diced, cooked, dehy.	1.00	4.2
Onions, minced, dehy.	.125	.52
Pepper, Red, dehy.	.125	.52
Gravy mix*	5.0	20.8

*Gravy mix

	<u>Percent by wt.</u>
Chicken Soup and Gravy Base	79.26
Salt	19.81
Poultry Seasoning	.66
M S G	.27

All ingredients to be nitrogen packaged together.

1st. DAY (CHILI AND BEANS)

Menu #5 Preparation

200 Lbs./hour

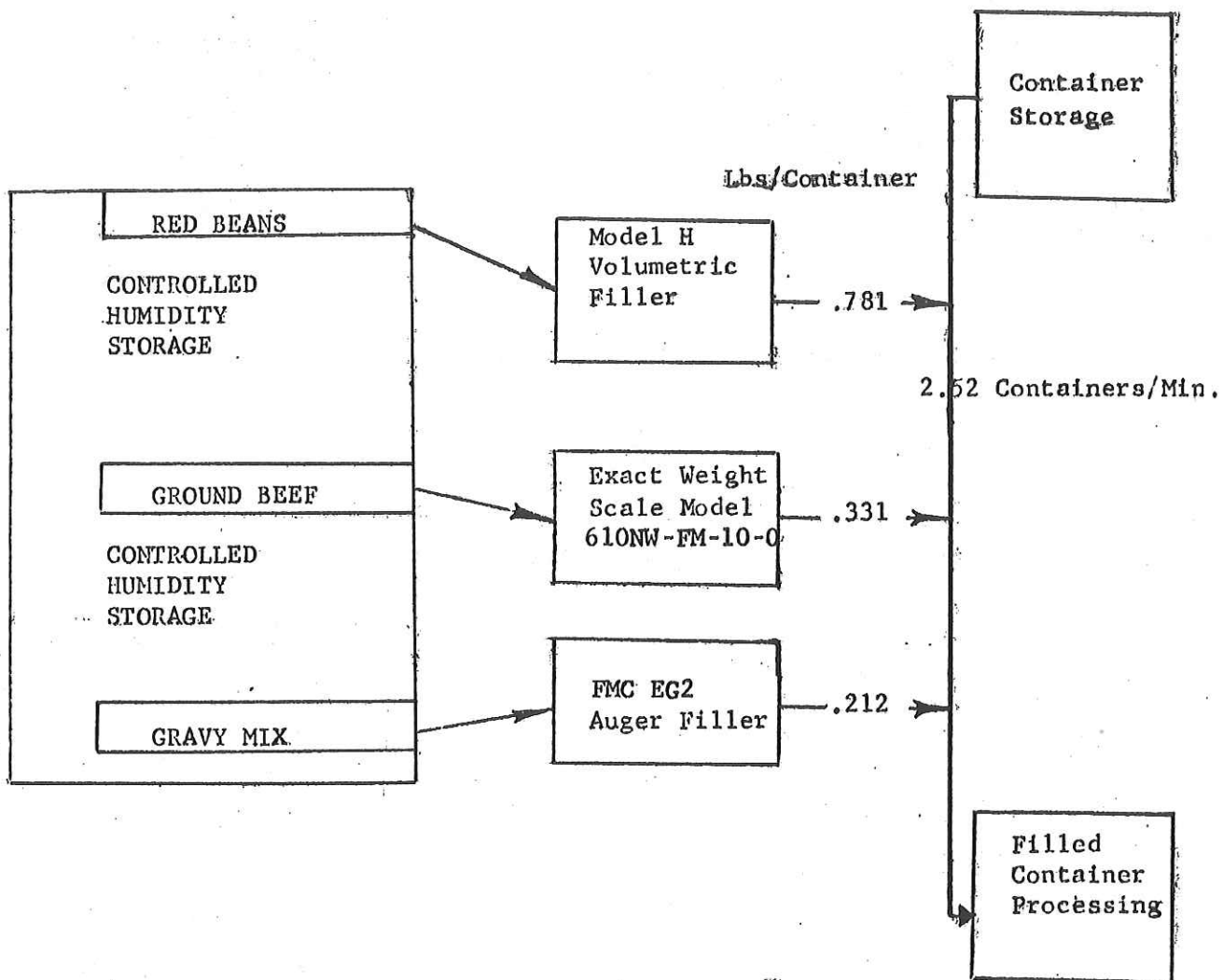

1st. DAY (BEEF LOAF & TOMATO GRAVY)

Menu #2 Preparation

200 Lbs./Hour

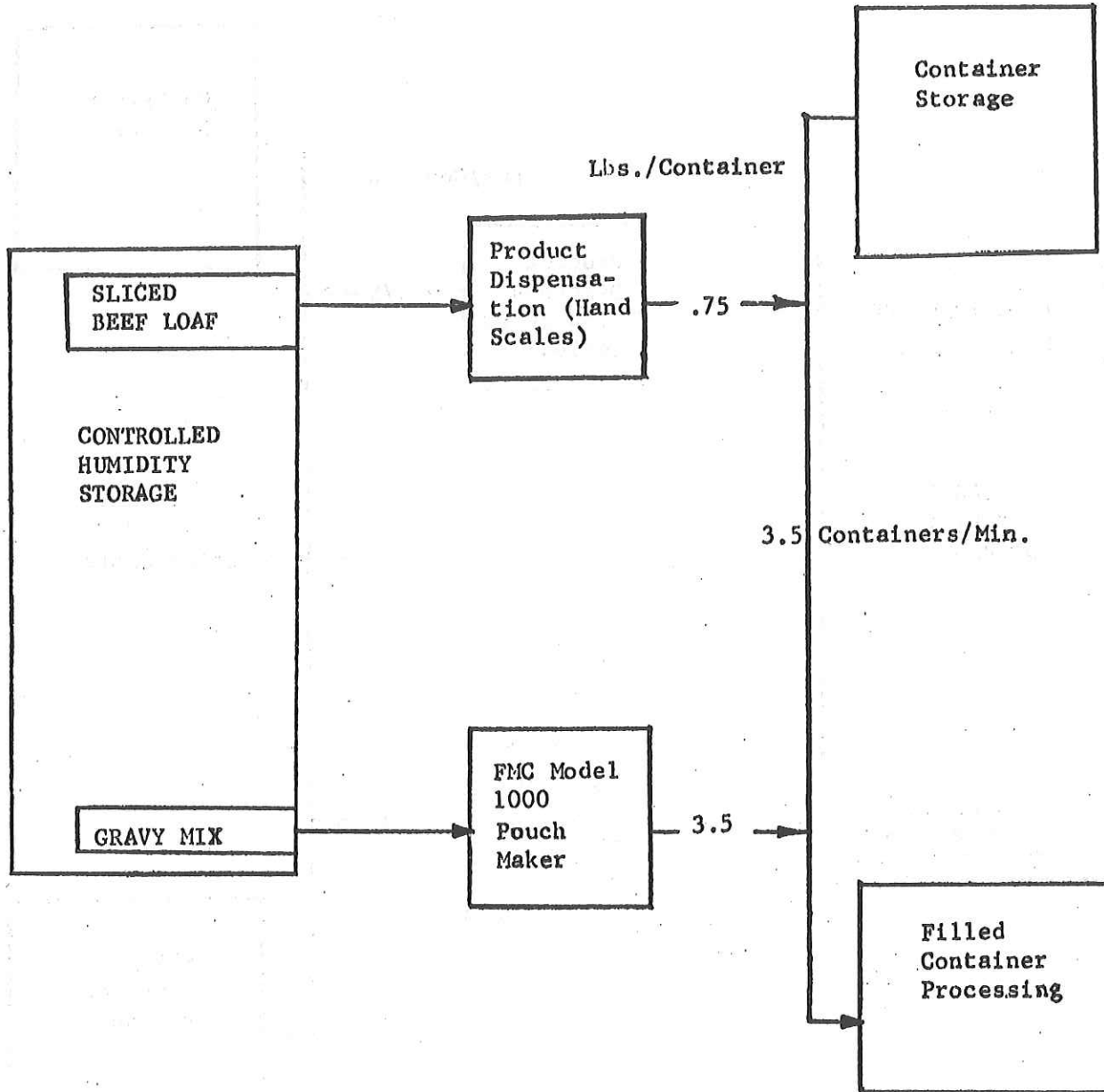

2nd. DAY (SLICED BEEF AND BROWN GRAVY)

Menu #3 Preparation

200 Lbs./Hour

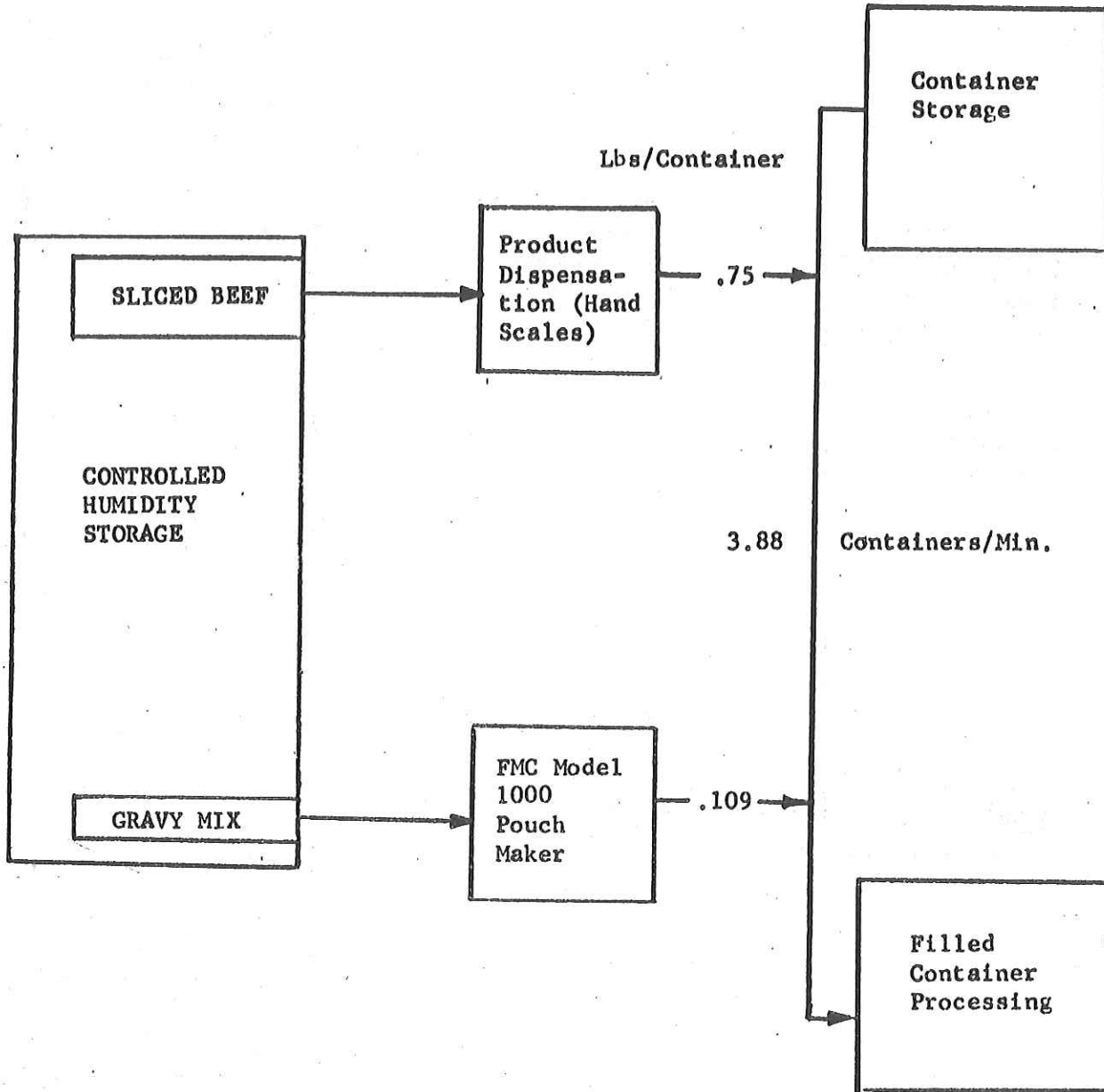

2nd. DAY (CHICKEN STEW)

Menu #6 Preparation

200 Lbs./Hour

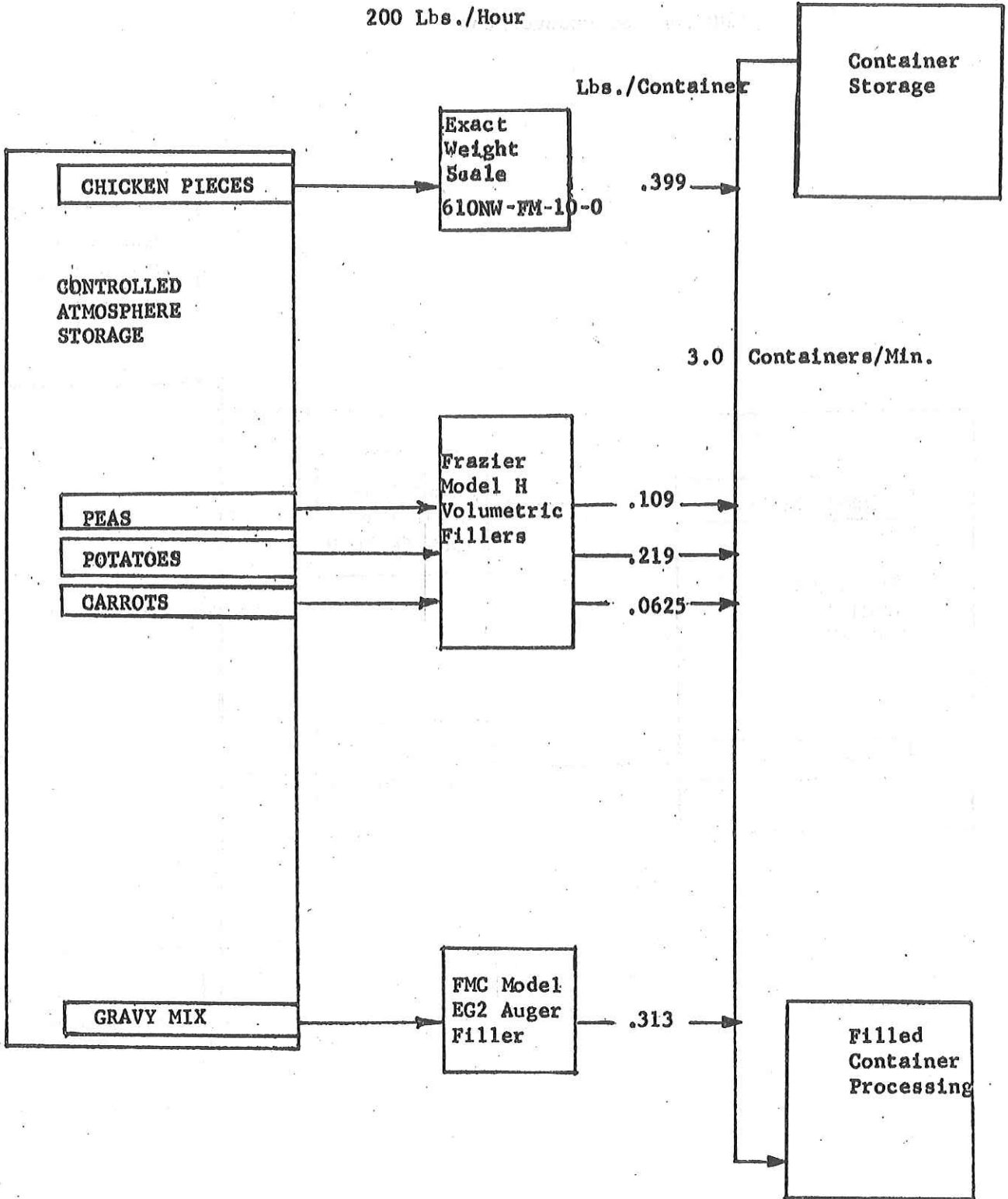

3rd. DAY (MEAT BALLS AND GRAVY)

Menu #1 Preparation

200 Lbs. of Product/Hour

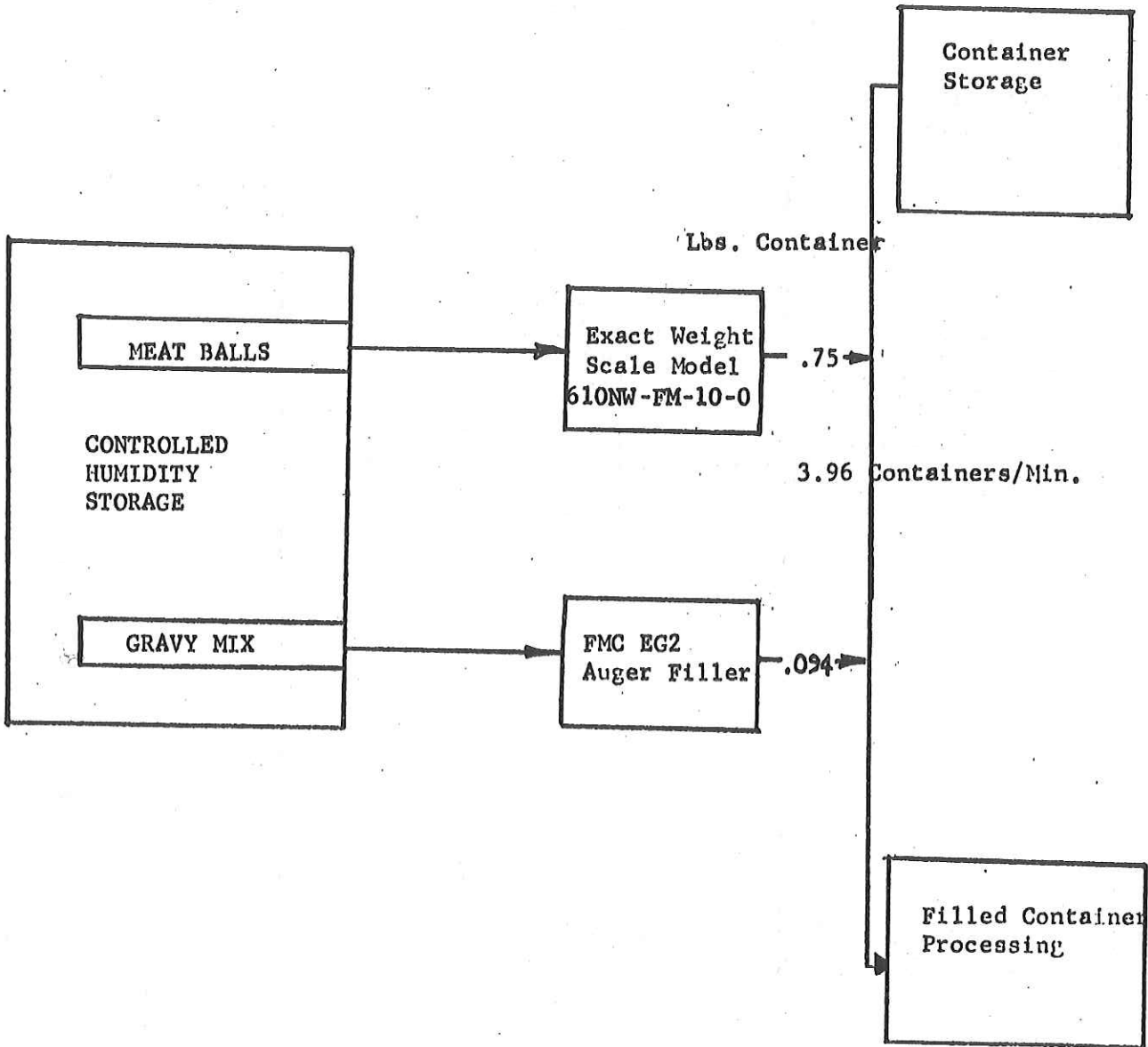

3rd. DAY (CHICKEN AND RICE)

Menu #4 Preparation

200 Lbs./Hour

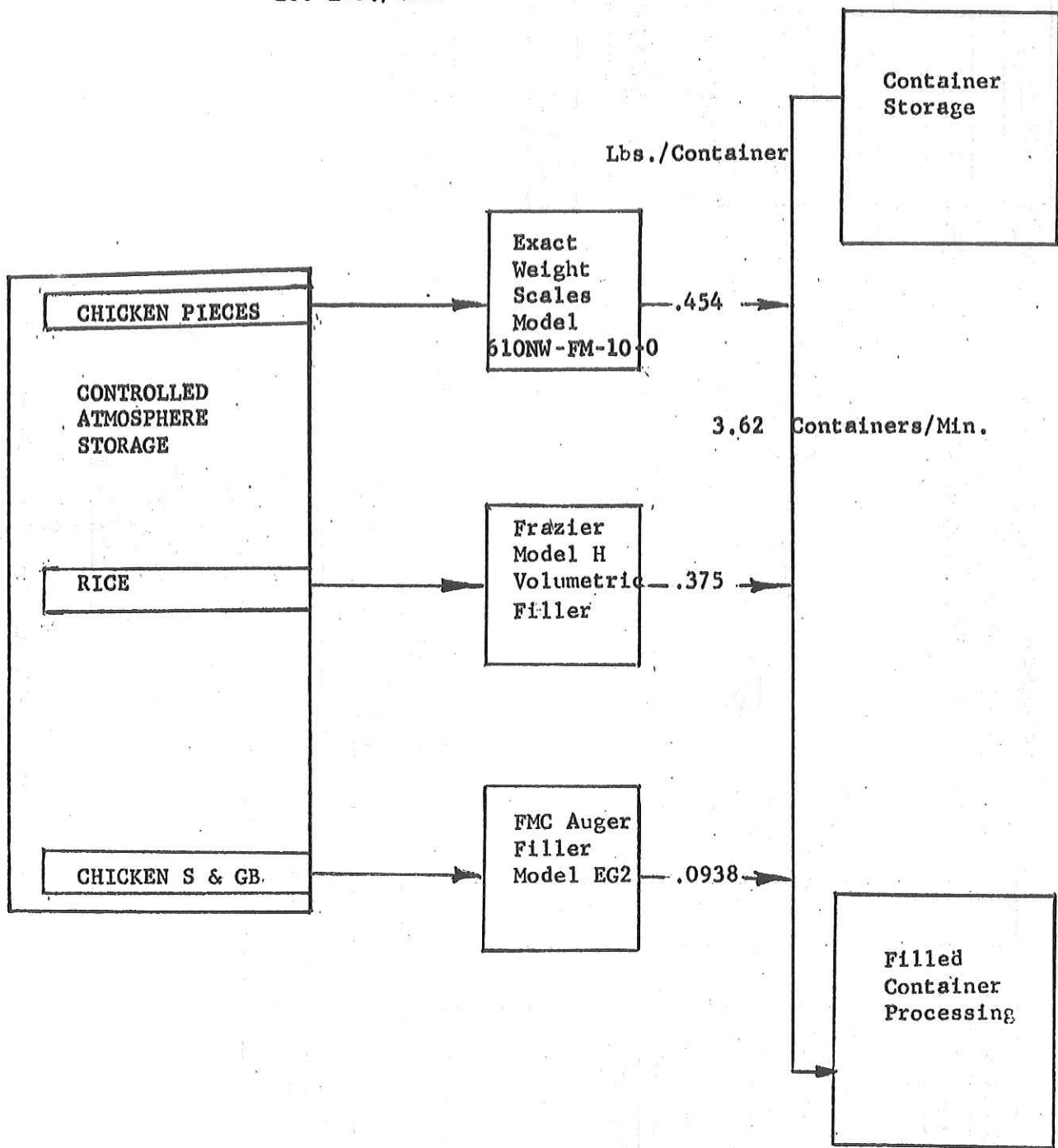

MENU # 1

PREPARED TWICE DURING
1 DAYS RUN OF MENU
(8 #25) AT 200 LBS/HOUR

62

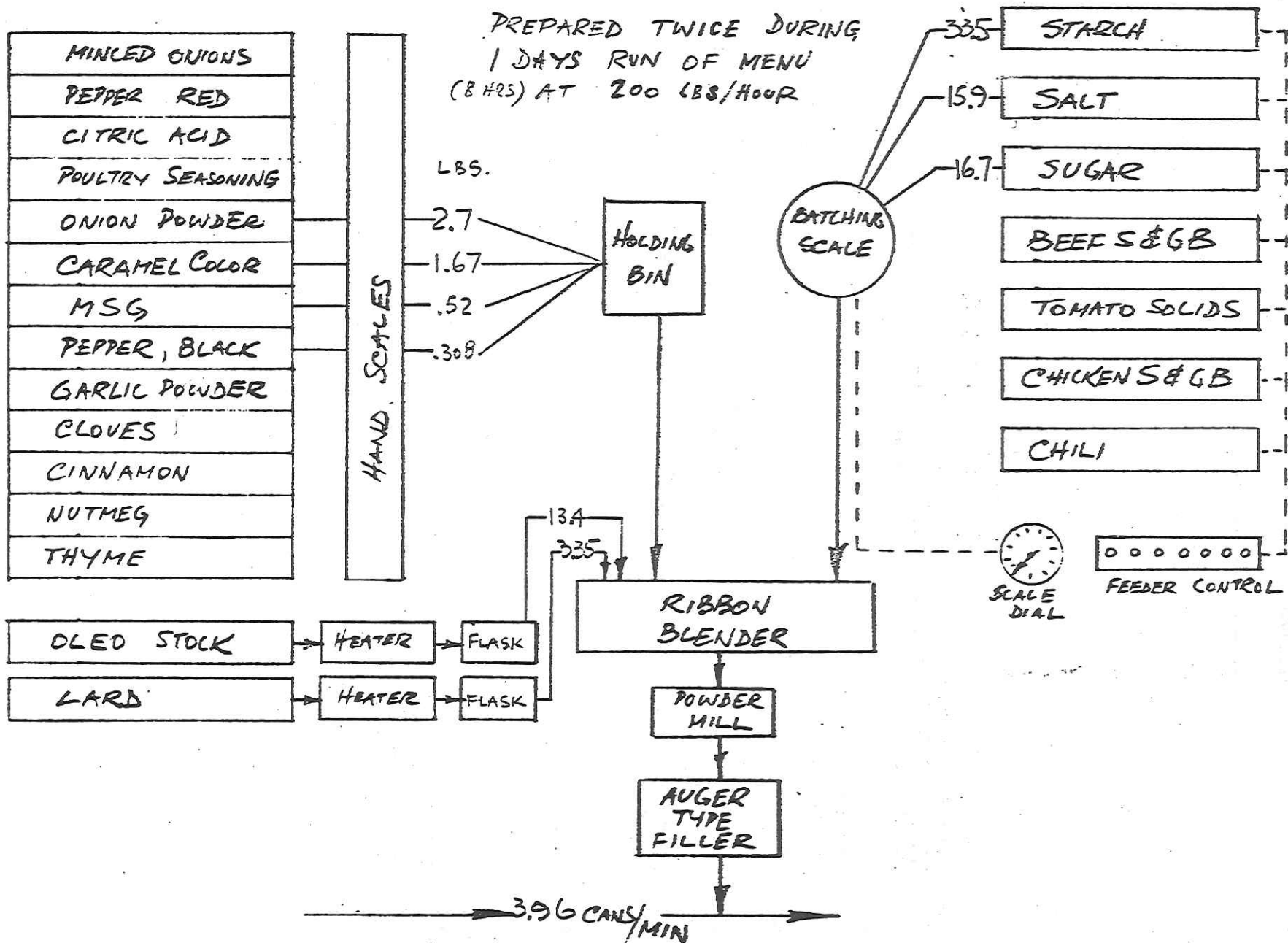

GRAVY MIX REPARATION MENU #2

63

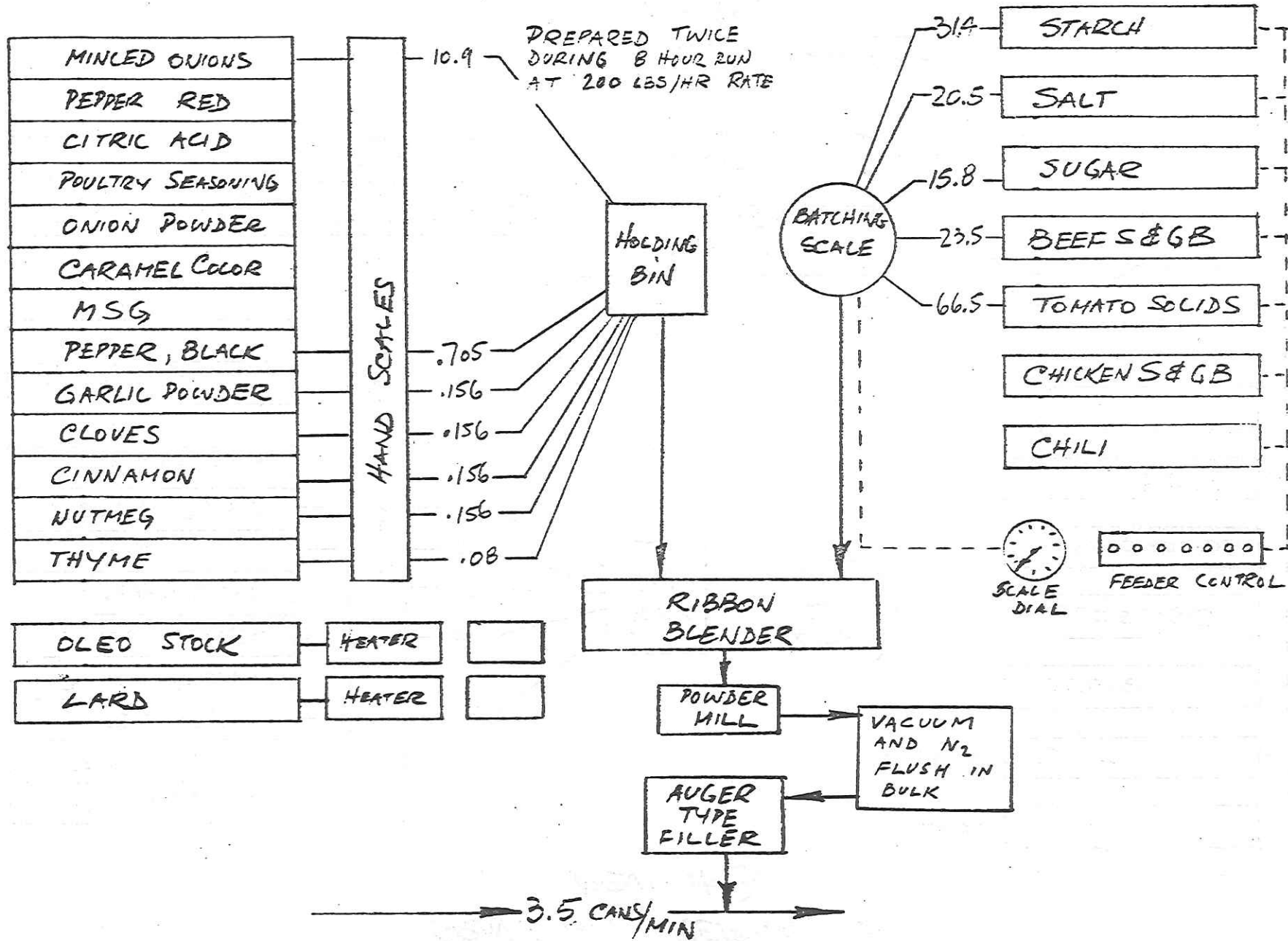

GRAVY MIX REPARATION MENU # 3

179

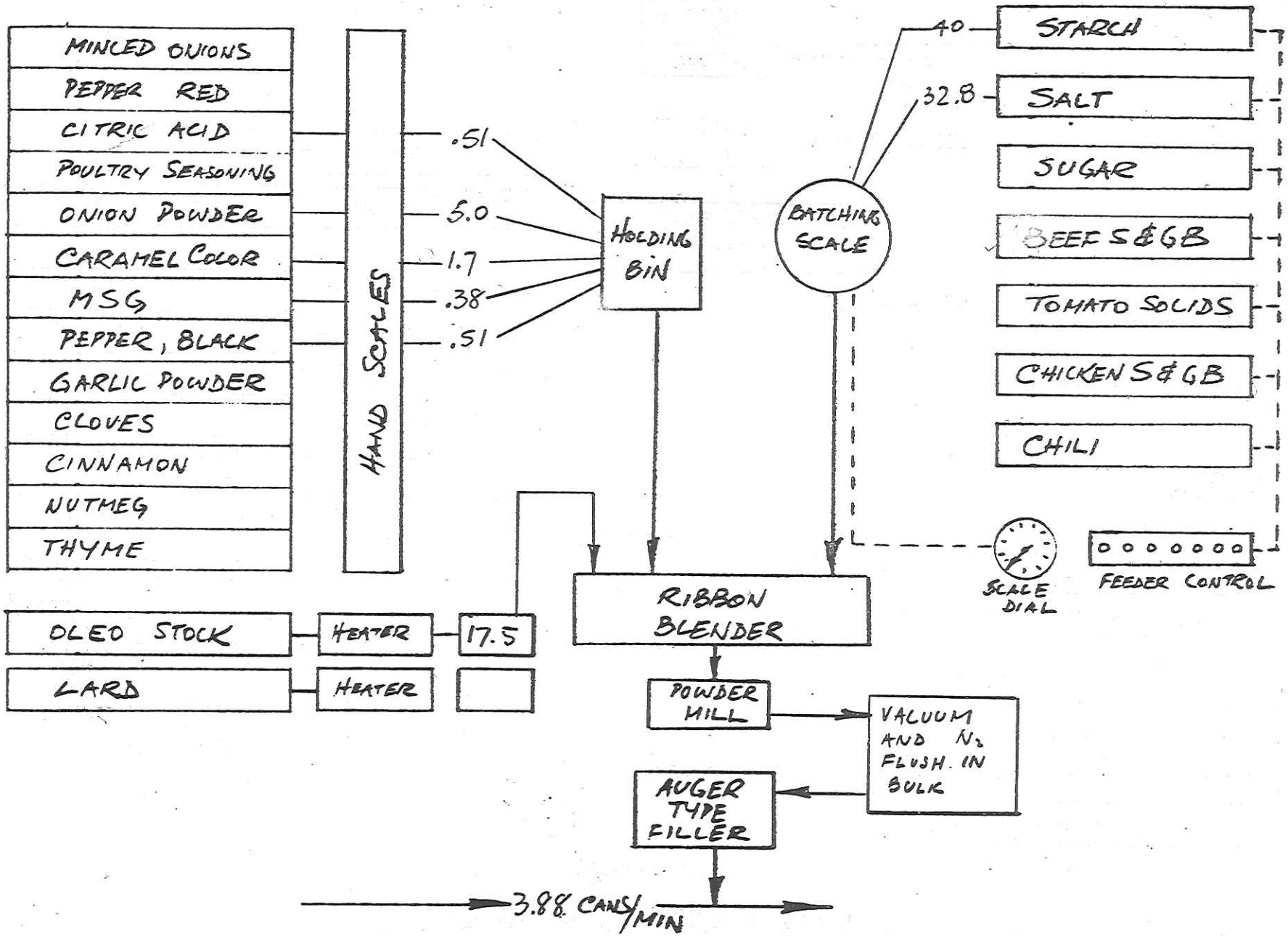

GRAVY MIX PREPARATION MENU # 4

- MINCED ONIONS
- PEPPER RED
- CITRIC ACID
- POULTRY SEASONING
- ONION POWDER
- CARAMEL COLOR
- MSG
- PEPPER, BLACK
- GARLIC POWDER
- CLOVES
- CINNAMON
- NUTMEG
- THYME

HAND SCALES

- OLED STOCK HEATER □
- LARD HEATER □

- STARCH
 - SALT
 - SUGAR
 - BEEF S&GB
 - TOMATO SOLIDS
 - CHICKEN S&GB
 - CHILI
- SCALE DIAL FEEDER CONTROL

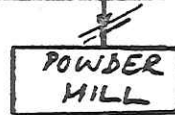
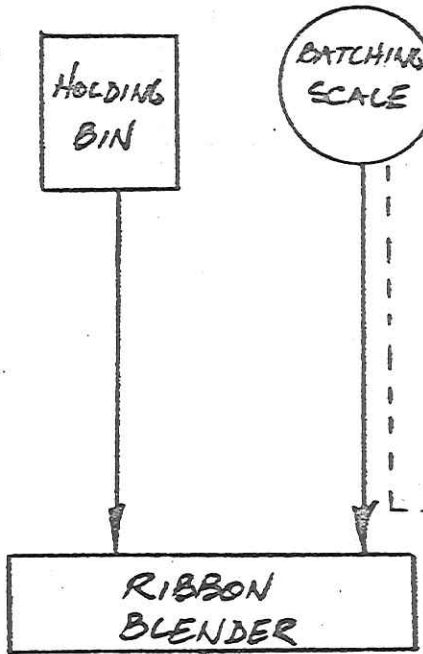

→ 3.62 CANS/MIN →

NOTE: FED DIRECTLY TO PRODUCT HOPPER OF FILLER.

GRAVY MIX PREPARATION MENU # 5

99

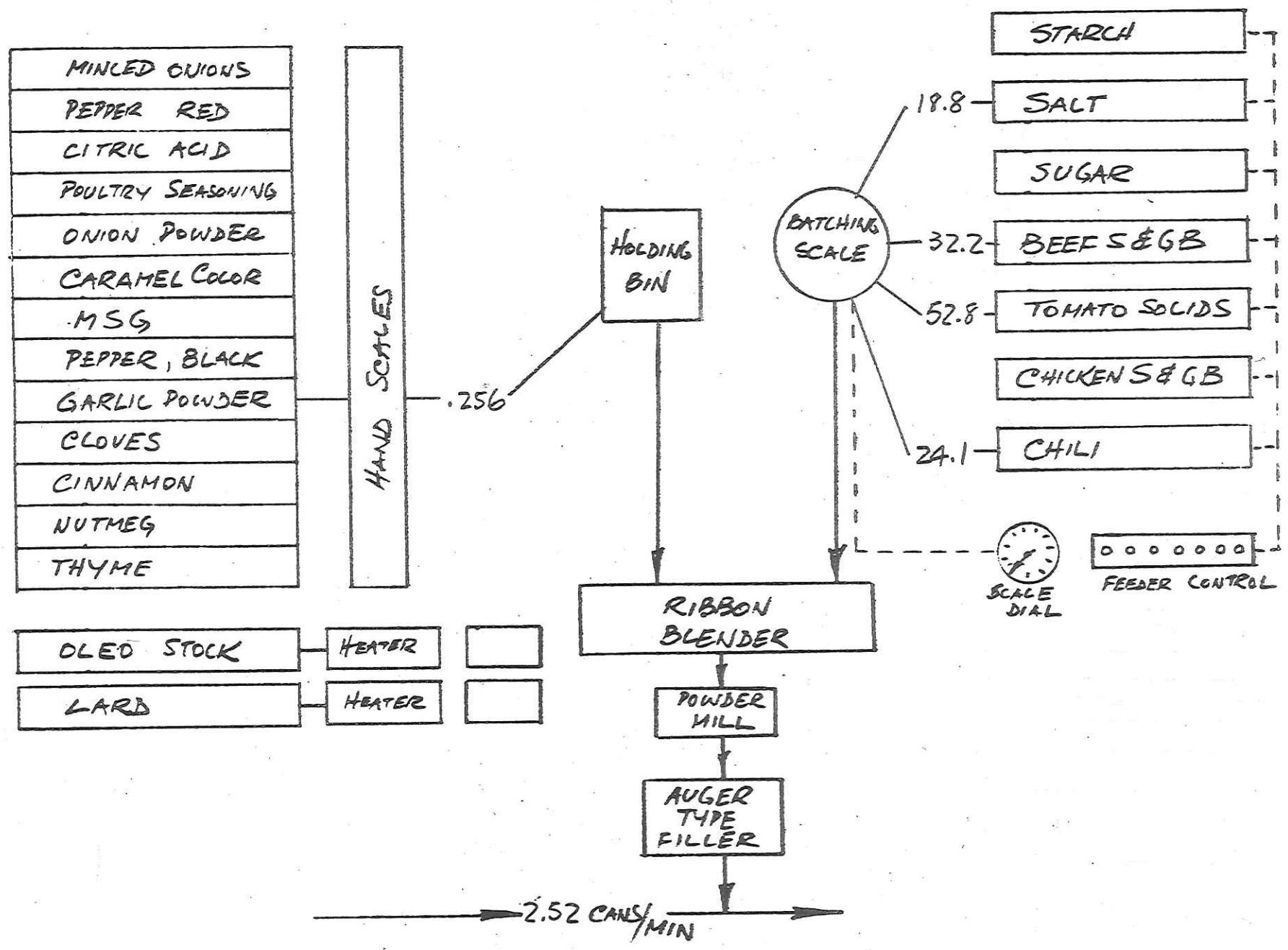

GRAVY MIX PREPARATION MENU #6

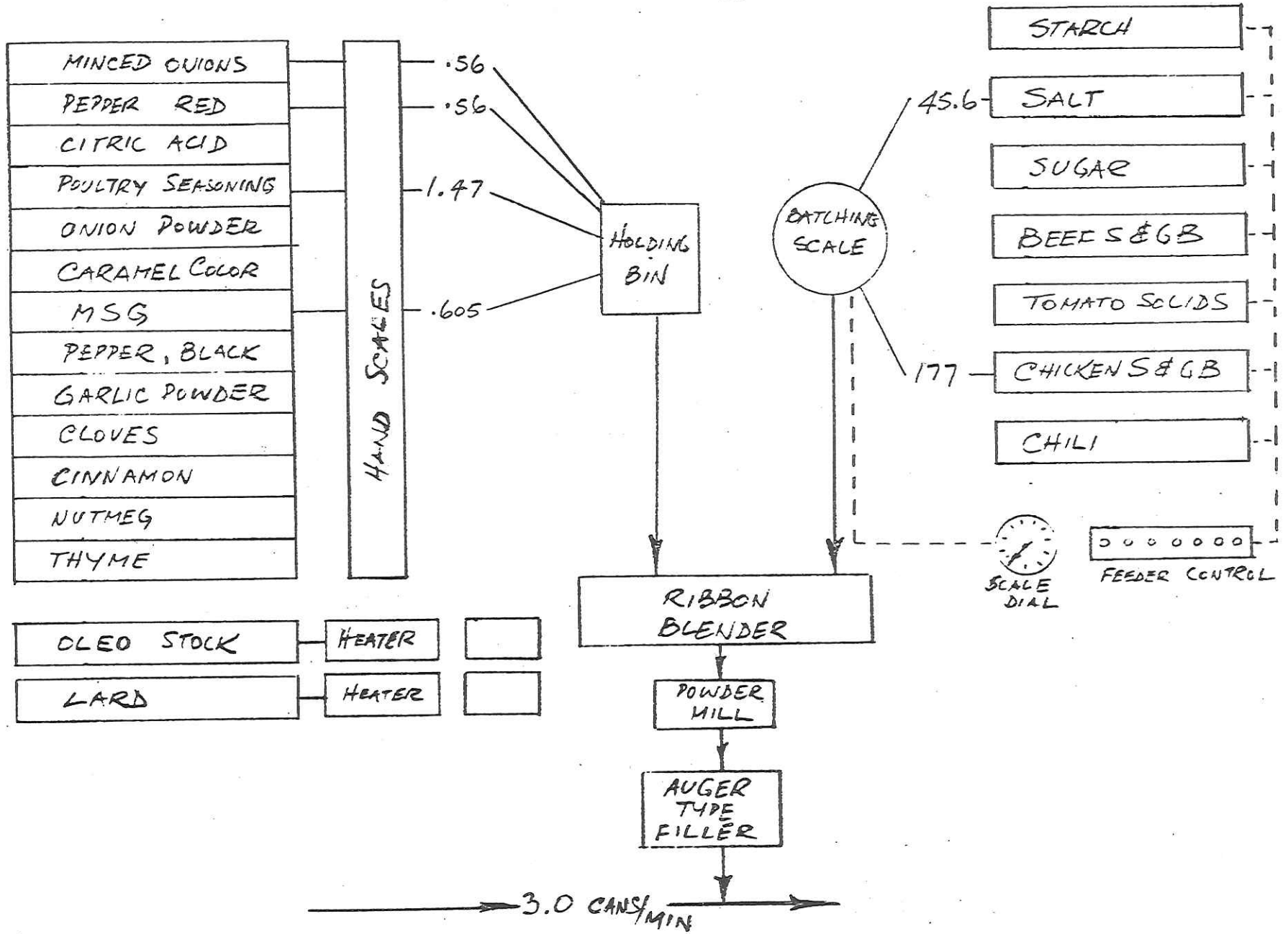

67

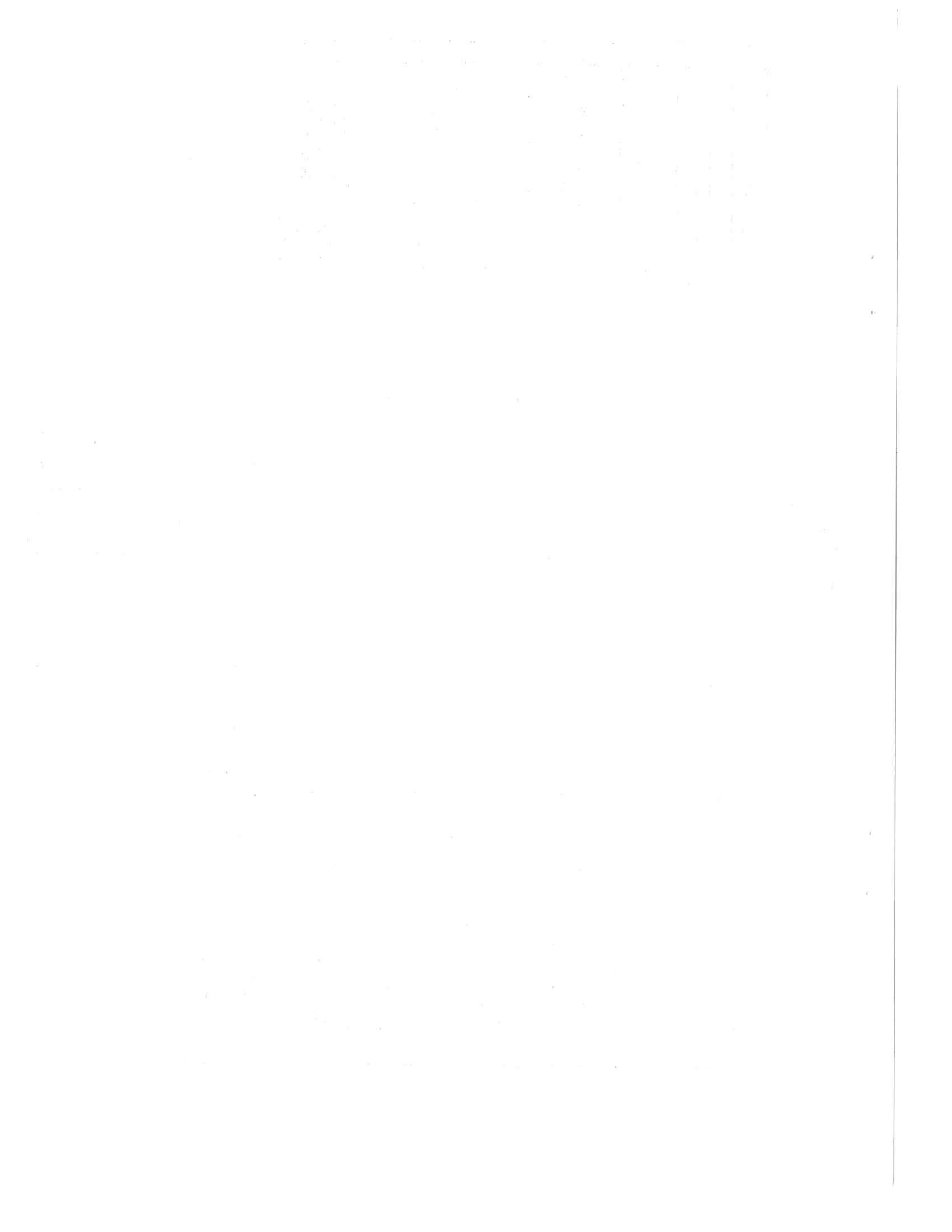

APPENDIX IV
ILLUSTRATIONS



Equipment used to determine characteristics of a volumetric filler.

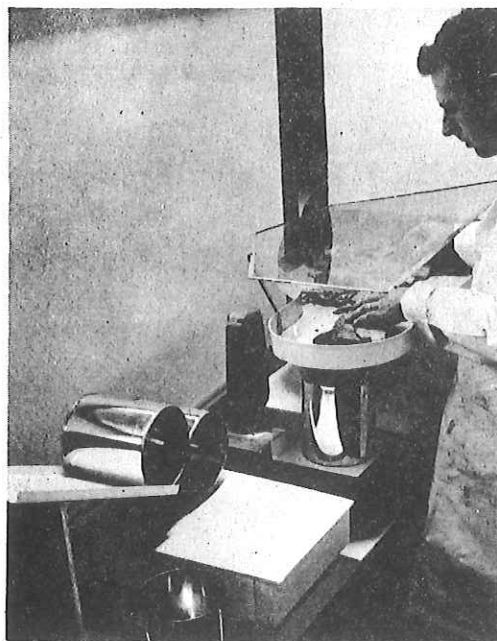

Technician conducting "rate of weighing" tests on meat slices.



Technician measuring chicken portions.

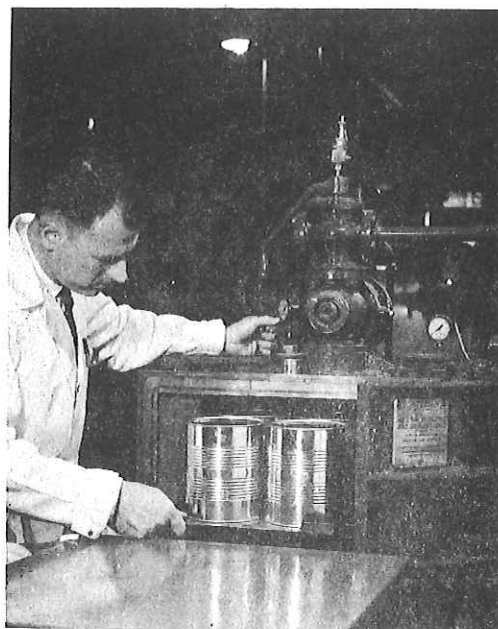

Technician using vacuumizing and N_2 flushing equipment on sample meals.

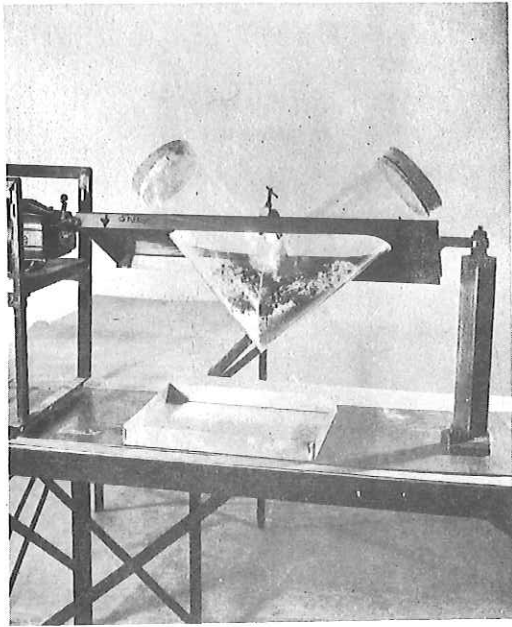

Equipment used to test twin-shell blending technique on gravy mixes.

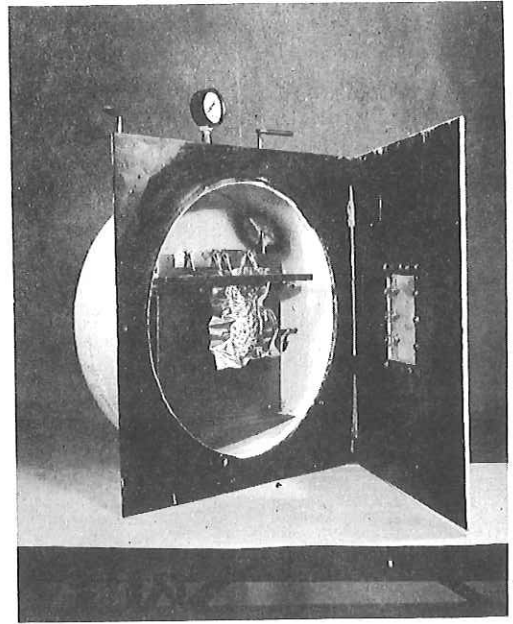

Equipment used to seal rice in a vacuumized pouch.

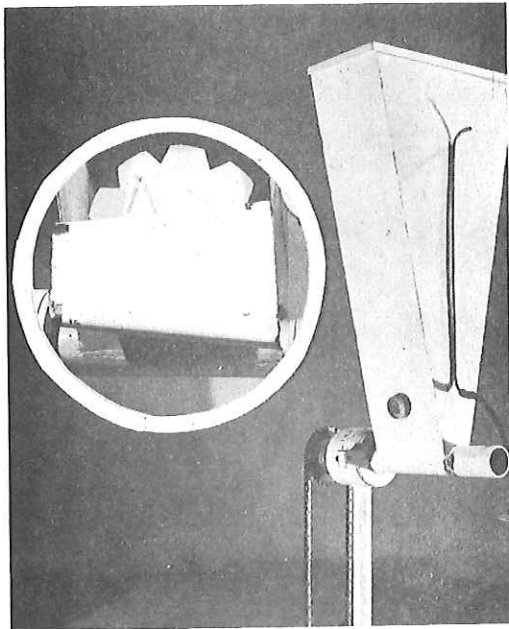

Hopper and auger used to test bulk storage and delivery.

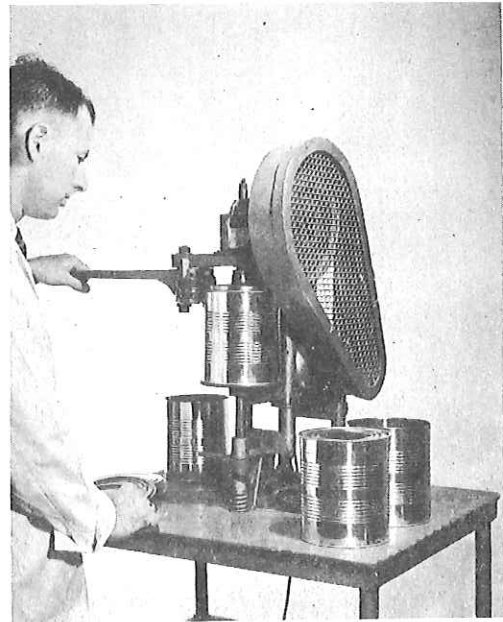

Sample menu containers being sealed.

