

THIS REPORT HAS BEEN DELIMITED
AND CLEARED FOR PUBLIC RELEASE
UNDER DOD DIRECTIVE 5200.20 AND
NO RESTRICTIONS ARE IMPOSED UPON
ITS USE AND DISCLOSURE.

DISTRIBUTION STATEMENT A

APPROVED FOR PUBLIC RELEASE;
DISTRIBUTION UNLIMITED.

Reproduced by



CENTRAL AIR DOCUMENTS OFFICE

WRIGHT-PATTERSON AIR FORCE BASE - DAYTON, OHIO

REEL-C

3053 B

A.T.I

63485

The
U.S. GOVERNMENT

IS ABSOLVED

FROM ANY LITIGATION WHICH MAY ENSUE FROM ANY
INFRINGEMENT ON DOMESTIC OR FOREIGN PATENT RIGHTS
WHICH MAY BE INVOLVED.

UNCLASSIFIED

63485

Materials and Techniques for Sound Control in Airplanes

(None)

**Berunak, L. L.; Wallace, R. L. Jr.; Brown, R. L. (Submitters)
Harvard Univ., Electro-Acoustic Lab., Cambridge, Mass.
OSRD, NDRC, Washington, D. C.**

(None)

OSRD-31

March '41 Unclass. U.S. English 255 photos, diagrs, graphs

A progress report on a study of materials and techniques for sound control in airplanes. Acoustic properties of aircraft structures are analytically studied so that their performance can be determined from a few simple measurements such as weight, stiffness, resistance to air flow, and depth of air cavities between the outer skin and the materials. Other items dealt with are window and panel transmission, and the vibration insulation of pilots' seats. The structure best suited for the acoustical treatment of airplanes appears to be one or more layers of porous materials spaced as far as practicable from the fuselage skin. Measurements showed that the thickness of windows near the propeller tips should be increased and that untreated fuselage panels attenuate sound very little. The vibration insulation of chairs must be done with great care so that the sound-wave amplitudes at some frequencies do not increase.

Copies of this report obtainable from CADO.

Comfortization (23)

Noise and Vibration Control (3)

Soundproofing (87570)

Sound level - Measurement (87553.5)

Materials, Acoustic insulating (60530)

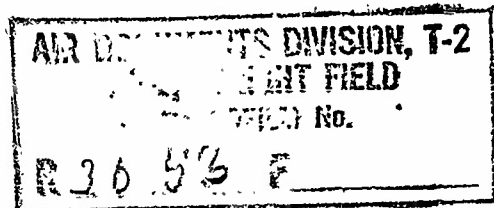

NATIONAL RESEARCH COUNCIL COMMITTEE ON SOUND CONTROL

Prof. P. M. Morse, Chairman
Prof. F. V. Hunt, Vice Chairman

Excerpts From
Progress Report of Project I
March 31, 1941

MATERIALS AND TECHNIQUES FOR SOUND CONTROL IN AIRPLANES

CONFIDENTIAL

UNCLASSIFIED

Submitted By

L. L. Beranek
R. L. Wallace, Jr.
R. L. Brown
H. W. Rudmose
R. H. Nichols, Jr.
W. J. Cunningham
W. S. Cramer
Anne Richmond, Sec.

Craft Laboratory, Harvard University
Cambridge, Massachusetts

NOTICE

Change of Page Numbering

In abridging this report, originally issued March 31, 1941, it has been necessary to change the page numbering. References given in the June 30, 1941, report referring back to the March 31 report should be translated as follows:

Page Numbers in Preliminary Report March 31, 1941	Equivalent Page Numbers, Abridged Edition
37 to 43	1 to 9
134 to 142	167 to 171
160 to 167	201 to 213
127 to 133	103 to 107 in June 30 report
108	129
18 to 25	216 to 239

TABLE OF CONTENTS

	Page
Abstract	I
Introduction	1
Calculation of Sound Levels -- Sound Surveys in Large Aircraft	1
B-18A	13
B-17C	29
XPBY-5A	51
PBM-1	71
DC-3B	91
CW-20	99
Acoustical Properties of Materials	107
a. Introduction	107
b. Equivalent Electrical Circuits and Design Objectives	113
Panel Transmission	167
a. Introduction	167
b. Apparatus	167
c. Experimental Results	171
d. Theoretical Treatment of the Sound Inside an Acoustically Treated Cabin	195
Window Transmission	201
a. Introduction	201
b. Experimental Apparatus	202
c. Theory	213
d. Measurements on Single Windows	214
e. Double Windows	239
f. Possible Improvements in Window Design	243
g. The Accuracy of the Measurements	244
Vibration Insulation of Chairs	251
a. Introduction	251
b. Conclusions on Chair Insulation	252

ABSTRACT

This is a progress report. The following subjects are discussed.

1. Calculation of Sound Levels.
2. Acoustical Properties of Materials.
3. Panel Transmission
4. Window Transmission
5. Vibration Insulation of Pilots' Seats.

The present report presents the results obtained up to April 1st in the hope that these will be useful to the Services in the interim preceding issuance of our final report.

On the basis of the work so far we can make the following general statements and recommendations:

In only one plane measured, the PBM-1, was the sound level less than 110 decibels (see pages 71 to 75). Sound level measurements should be made with a sound level meter possessing a flat response and calibrated to closer tolerances than those provided for in the A. S. A. Standards. It is suggested that a central calibrating station be designated which will bring the instruments of all companies and testing laboratories into agreement.

Large reductions in sound level and structural vibration might be achieved by using 3 to 2 gearing and properly indexing the propeller with respect to the motor shaft such that the second order motor vibration cancels out a portion of the propeller fundamental. All openings from the pilot's compartment to the outside, or to the bomb bay, through which cables pass, should be sealed with felt washers or with rubber bellows.

Ventilation should be by ventilator ducts, lined with sound absorbing material.

Of the possibilities investigated thus far the structure best suited for the acoustical treatment of airplanes appears to be one or more layers of porous material spaced as far as practicable from the fuselage skin. At 110 cycles for one particular material about twice as much absorption can be obtained with 2/3 as much weight of material merely by changing the material spacing (see pages 125 and 126). The material should be mounted in as large panels as practicable and the edges should be sealed to prevent easy leakage of air. The material should be two or three inches thick for best absorption at the higher frequencies. (See page 125). Further sound reduction in the pilots' compartment over that now observed can be obtained by spacing the sound absorbing material four to six inches out from the aluminum skin, or

by increasing the weight of the material (or both). Acoustical materials near the propeller tips should be somewhat heavier than in other locations.

Measurements show that untreated fuselage panels attenuate sound very little. Each small panel lying between longerons and bulkhead stiffeners has its own resonance frequency. A thin sheet of mica cemented to each panel will damp these vibrations, but does little good if the longerons and the panel vibrate as a whole. (See page 186.) Preliminary results show that below 500 cycles lightweight acoustical materials contribute almost nothing to the attenuation of transmitted sound, but do absorb sound if spaced far enough from the outer skin. (See page 195.)

Measurements have been performed on windows of various thicknesses and sizes made from a number of common materials. These results show that it seems worthwhile to increase the thickness of those windows which are near the propeller tips, even at the expense of added weight (page 243). Double windows are inferior acoustically at the lower frequencies to single windows of the same weight (page 239). A small weight dissipatively coupled to the center of a window pane will decrease the transmission through it by a significant amount. (See pages 243 and 244.)

Vibration insulation of chairs must be done with care since the amplitudes at some frequencies may be increased when elastic mounts are added unless the mounts are properly positioned and oriented.

INTRODUCTION

An important objective of this project has been to devise ways of considering acoustic properties of aircraft structures analytically in order that their performance may be determined from a few simple measurements, such as weight, stiffness, resistance to air flow, depth of air cavities between the outer skin and the materials, etc. Graphs from which one can calculate the attenuation of windows of various sizes, and the attenuation of sections of fuselage have been partially compiled. Similarly, graphs for calculation of the sound absorption of materials are included. Still to be developed are simple charts for calculating the proper elastic mounts for pilots' seats and charts from which the sound levels in an airplane can be calculated for a given design.

CALCULATION OF SOUND LEVELS -- SOUND SURVEYS IN LARGE AIRCRAFT

Sound surveys have been made in five different planes; an American Airlines Douglas DC-3B, U. S. Army Douglas B-18A and Boeing B-17C, and U. S. Navy Consolidated XPBY-5A and a Martin PBM-1.

The purpose of these surveys was to obtain data regarding the character of the sound spectrum of an airplane, and to determine the principal sources of the noise in all parts of the plane. These data would then serve as a guide for our experiments on sound control, and as a check on the accuracy of calculation of sound levels from the design of a plane.

The equipment used (Fig. 1, page 3) included a combination sound level meter and a continuously variable sound analyzer, together with its associated dynamic microphone, the analyzer having two band pass filters, one 5 cycles wide and the other 200 cycles wide; a high speed level recorder operating with a 50 db. volume range; and, in the later tests, a band pass filter set. The overall acoustical calibration of the microphone and sound level meter, using the flat network, is shown on page 5. All measurements were made using the flat network, and the sound levels in decibels are based on the A. S. A. reference level of 10^{-16} watts per square centimeter. The analyzer frequency scale is divided into two parts; 10 to 1000 cps and 1000 to 10,000 cps. A synchronous motor is used in sweeping the frequency range, and a marker automatically records every 100 cps division point on the wax paper of the high speed level recorder. The 5 cycle band width was used from 10 to 1000 cps, and the 200 cycle band width was used from 1000 to 10,000 cps. The filter set has a single control gang switch which permits a rapid shift from one octave to the next. Sample data using both the analyzer and filter set are shown

on page 7. The overall sound level is recorded at the beginning of each test. In computing the octave levels from the filter set data, necessary correction for the insertion loss of each section is made. These insertion losses are shown in Table III, below. All data graphed in this report have been corrected.

TABLE III
Insertion Loss of Filter Set

<u>Octave Range</u>	<u>Insertion Loss</u>
Overall	add 5 db.
Below 50 c.p.s.	add 10
50 to 100	add 10
75 to 150	add 9
100 to 200	add 9
150 to 300	add 9
200 to 400	add 9
300 to 600	add 8
400 to 800	add 8
600 to 1200	add 8
800 to 1600	add 8
1200 to 2400	add 8
1600 to 3200	add 8
2400 to 4800	add 8
above 4800	add 8

The tests were made with the analyzing and recording equipment mounted in one part of the plane. In all cases the apparatus was shock mounted to reduce the disturbing effects of vibration. There is no indication on the records of any such disturbance. The microphone was connected using various sections of cable, depending upon the size of the plane, and wherever bulkhead doors were closed, short, flat "jumpers" permitted connection under the bottom of such doors. Vibration measurements were made using a damped dynamic vibration pickup associated with the apparatus already described.

All spectra have been plotted in terms of sound energy per octave. In the surveys made with the filter set, these data were obtained directly simply by adding the insertion loss of the filter as a correction. Where only harmonic analyses were obtained, correction factors depending upon the band width of the analyzer, the type of spectrum and the octave involved, were applied. The overall level obtained at each station is plotted on the left hand side of the page and is indicated by a dash with the associated station number. Along the bottom of the page, the frequencies of the various harmonics of propeller, engine and exhaust are indicated by dots.

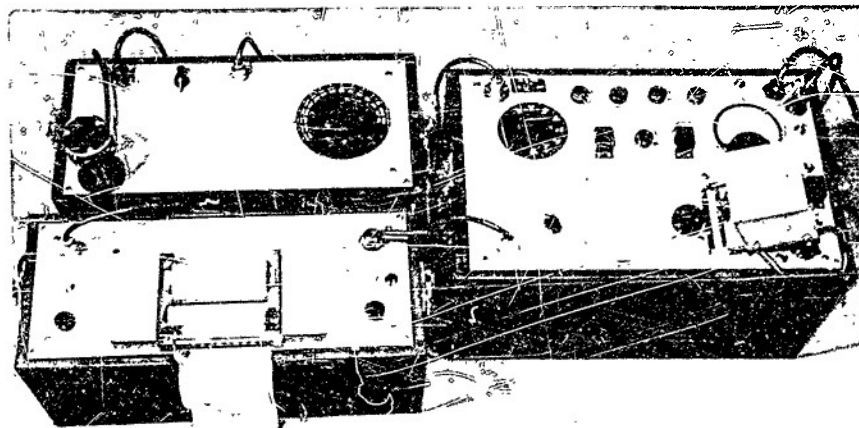
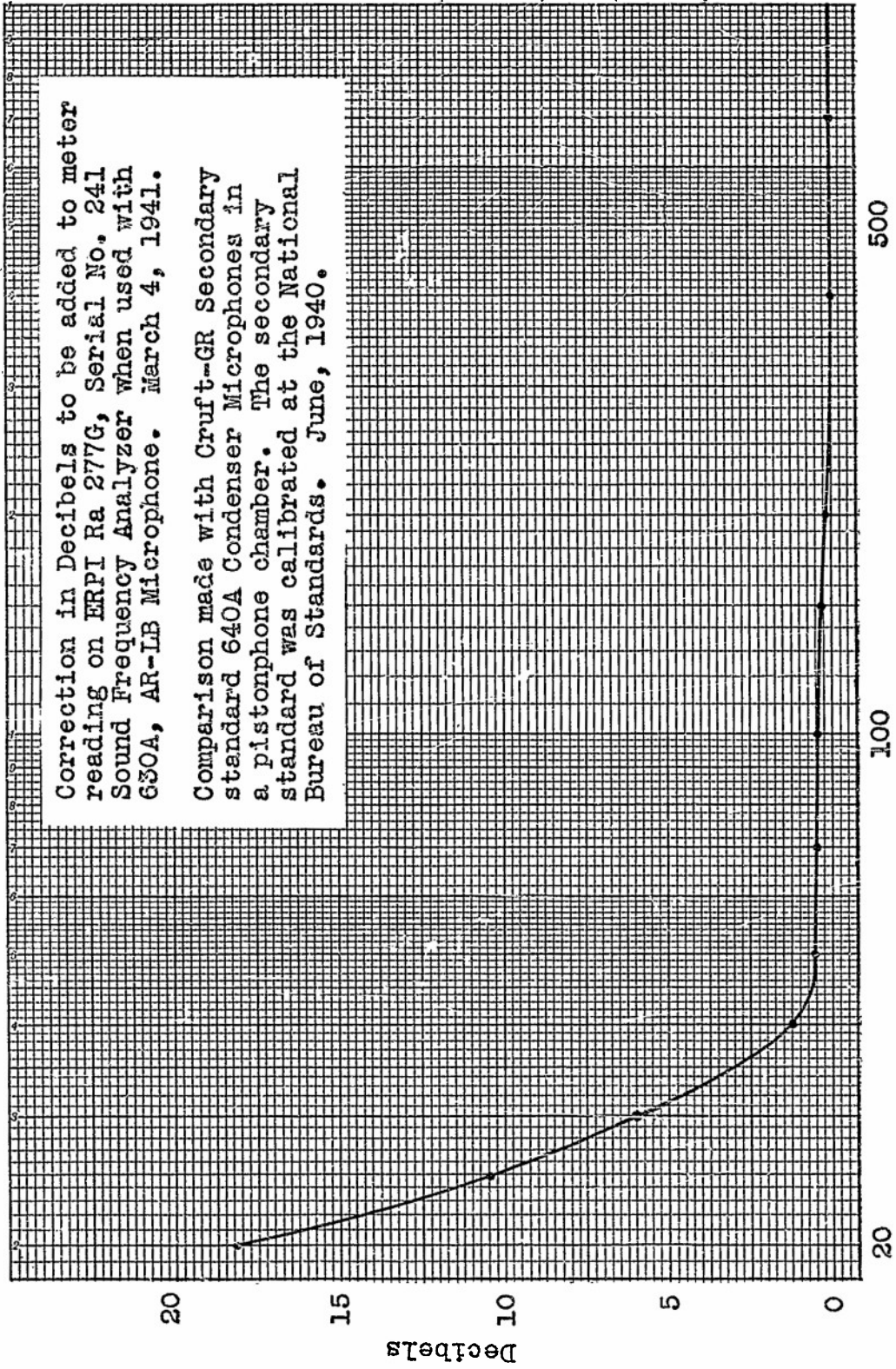

Fig.1. Filter set, sound frequency analyzer, and automatic recorder.



Correction in Decibels to be added to meter reading on ERPI Ra 277G, Serial No. 241 Sound Frequency Analyzer when used with 630A, AR-LB Microphone. March 4, 1941.

Comparison made with Cruft-GR Secondary standard 640A Condenser Microphones in a pistonphone chamber. The secondary standard was calibrated at the National Bureau of Standards. June, 1940.

FREQUENCY CPS

Correction in Decibels to be added to meter reading on ERPI Ra 277G, Serial No. 241 Sound Frequency Analyzer when used with 630A, AR-LB Microphone. March 4, 1941.

Comparison made with Cruft-GR Secondary standard 640A Condenser Microphones in a pistonphone chamber. The secondary standard was calibrated at the National Bureau of Standards. June, 1940.

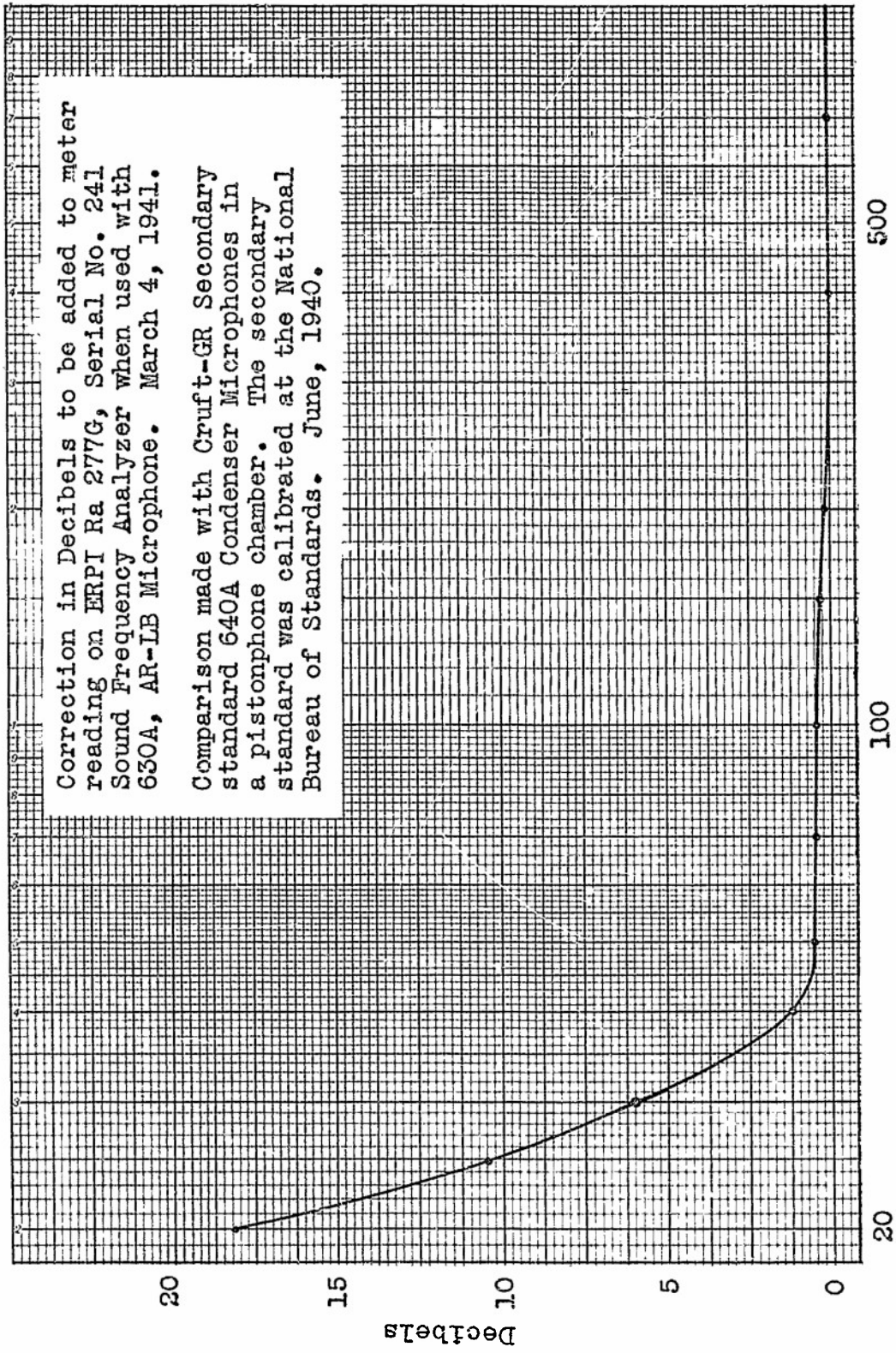

FREQUENCY CPS

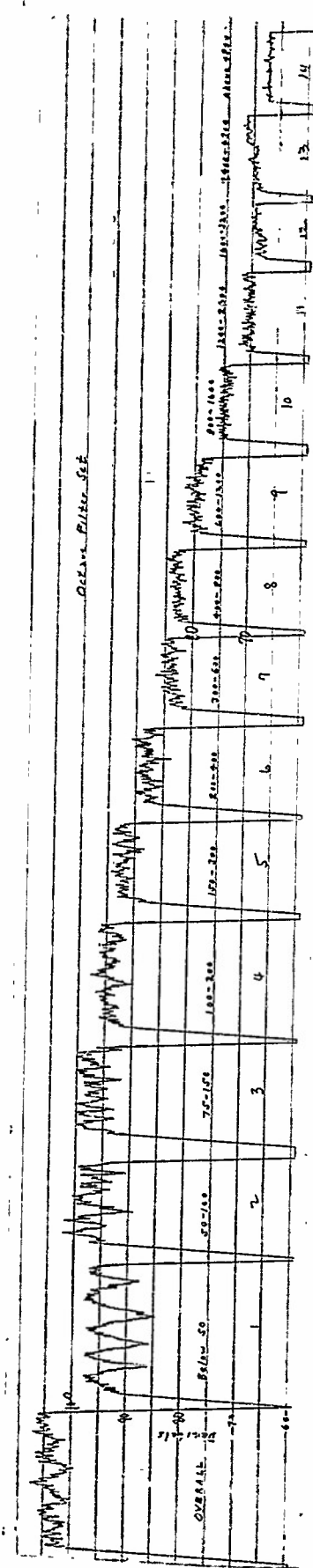
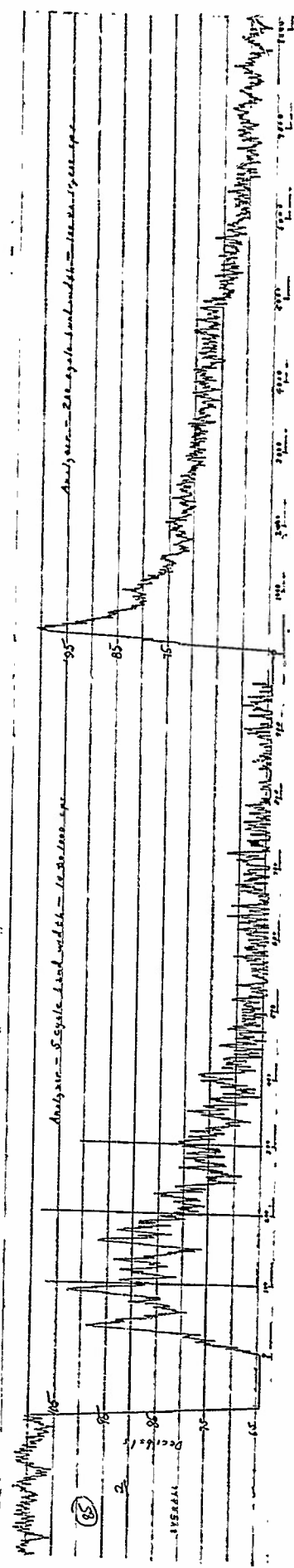

PBM-1 CO-PILOT'S HEAD R.P.M. 1700 INDICATED AIR SPEED 130 NMPH. H.P. 750
 AIRPLANE 56P4 FLAT WEIGHTING NETWORK M.P. 2.4" OUTSIDE T = -8°C PROPELLER TIP SEP. 17.6"
 MARCH 18, 1941 A.S.A. STANDARDS REF. LEVEL. ALTITUDE 5000 FT. GEAR RATIO 9/16 PROPELLER DIA. 14.5'

The general character of the spectra of the airplanes tested discloses that most of the energy lies in the frequencies below 1000 cycles per second, reaching a maximum at approximately 100 cycles per second. This is especially true of spectra taken at stations near the plane of the propellers, while those taken at stations in the rear of the plane remote from the propellers show that the higher frequency components become significant, there being no acoustical treatment to absorb them.

A remark should be made about the rate of decrease of sound level at the high frequencies. Data taken in a B-18A and a XPBY-5A indicate that the rate of decrease is slightly greater in the B-18. In fact, the PBY has the smallest rate of decrease of all four, and this was the only plane not treated with acoustical material. The conclusion must be that the higher frequencies are being attenuated or absorbed in the treated cabins. A comparison of the PBY and the PBM shows this difference to be from 5 to 8 db. for frequencies above approximately 200 cycles. While 5 to 8 db. reduction may not seem an enormous amount, the increase in comfort and greater ease of conversation in the treated plane is strikingly apparent to the observer.

To illustrate the increase in high frequencies in the rear of the plane, compare stations 1 (pilot), page 75, and 17 (rear), page 87 for the PBM-1. At station 1, the level begins to drop after approximately 150 cycles, whereas at station 17, the spectrum is essentially uniform to 700 cycles. At 100 cycles the level is about 6 db. higher at station 1 than at station 17, while at 1000 cycles it is 10 db. lower. Such a differential makes the character of the sound at the two stations entirely different.

The various factors that contribute to the spectrum are propeller noise, engine noise, exhaust noise, and aerodynamic noise. In the forward part of the plane, the propeller and engine noise are most disturbing, because their frequency components are low and quite intense. In the rear of the plane the aerodynamic and exhaust noises are more evident, as they are not completely masked by the lower frequency noise of the engine and propeller.

With so many sources of noise, it is inevitable that under certain conditions beats will occur. Possibly the most obvious beats that occur in multiple motor planes are those due to the motors being out of synchronism. If it were possible to accurately control this synchronism, significant reduction in vibration and acoustic levels could be realized, if the propellers were properly phased. Beats can also occur between, say, the second harmonic component of the engine and the fundamental component of the propeller. Using a three blade propeller and a 11 to 16 gear ratio, the fundamental of the

propeller is just two cycles higher than the second harmonic of the engine. This beat will always be present under all conditions of flight, and in addition to producing a fluctuating sound level, causes unnecessary vibration of the fuselage. A more favorable gear ratio should be chosen, say 3 to 2.

In Report No. 2474 of the Douglas Aircraft Company, the effect of the 3 to 2 gearing on sound and vibration in a DC-3 airplane is discussed. Excerpts from this report follow:

Purpose of Report.

To measure the effect of 3 to 2 gearing on the sound and vibration in a DC-3 airplane as compared with the standard 11 to 16 ratio and the dynamic suspension mount.

Results and Discussion.

It will be noted that the average vibration velocity is 9 db. less than that for the 11 to 16 gear ratio and 7 db. less than when equipped with the dynamic suspension. A comparison of the sound level tests shows a 4.4 db. improvement over the 11 to 16 gear ratio and a 3.8 db. improvement over the dynamic suspension installation. This improvement may be considered even better than shown by these figures when it is stated that no beat exists in the sound or vibration. On an airplane equipped with the standard 11 to 16 gearing, the beats cause a plus and minus 5 db. change in level.

The beat is the result of a difference in the frequencies of the sound and vibration caused by the passage of the propeller blades past the fuselage and the vibration and resulting sound of the second order of engine unbalance. With the 11 to 16 ratio this difference is approximately 2 cycles per second. With 3 to 2 gearing both of these sources have the same frequency so no beat can occur. However, due to the fact that there are still two separate sources emitting sound and vibration of the same frequency, there may be an addition or cancellation depending upon the phase angle between the two sources. It is believed that the large reduction in sound and vibration levels is due to this effect. Through some chance the propellers on the plane tested were indexed with respect to the crankshaft in such a manner that the phase angles of the sound and vibration from these two sources were 180° apart and cancellation resulted.

Conclusion.

These tests show a large decrease in the sound and vibration in the cabin. The reactions of all the observers on board during the test checked the measured results. The improvement was so outstanding that it is believed that a detailed study of the installation should be made. This study should include tests showing the effect of indexing of the propeller and the effect of the engine mount characteristics on the sound and vibration in a plane equipped with the 3 to 2 gearing.

This seems to be a definite method of reducing the sound level and the structural vibration level without adding weight.

We have had no chance to experiment with a procedure that could be followed in indexing a propeller, but it seems reasonable that it could be done at the airplane factory. A sound level meter could be placed, say, at the pilot's position, and the propeller adjusted on the motor shaft to such a position as to produce minimum sound level. The removal of the 2 cycle beat that occurs when a 11 to 16 gear ratio is used would be of considerable advantage from the psychological point of view and the elimination of detrimental vibration in the fuselage as well as the reduction of the sound level.

Our measurements and those of the Douglas and Boeing Aircraft Companies indicate that the propeller noise can be reduced by increasing the minimum separation of the propeller tips from the fuselage. This, of course, is a design problem for the aircraft engineers. However, it presents such acoustical and vibrational advantages over the close separation in present use that the recommendation of increased separation must be made and should be given definite consideration.

Several analyses were taken to compare transmission of sound through windows with transmission through the skin. All such comparisons indicate that the windows have much less attenuation, especially where they are thin and large. The highest sound level (131 db.) obtained in these surveys was in the XPBY-5A, the microphone being held two inches away from a thin plexiglas window and directly in the plane of the propeller. The pilot, unfortunately, sits with his head only about 10 inches in front of this particular window.

A great amount of information is contained in these records; however, we have not had sufficient time to study the records in detail and present such results in this report. It is reasonable to conclude that the levels measured are too high for men to be subjected to for long periods of time and retain good efficiency. In addition, the present acoustical

treatments do little good at the lower frequencies.

At present, measurements are being made under our direction at the propeller test stand at Wright Field which will give data relating the noise made by a propeller to its pitch, r.p.m, and horsepower. It is planned that we devise some means by which a sound level survey of the exterior of a fuselage can be conducted. Such data, together with the propeller test stand data, would serve as a starting point in predicting sound levels in a plane prior to its construction. A detailed study of our present data will be made to determine what are the principal components of the noise in each compartment, what is the source or sources of such components, and what is the variation of these components in any compartment as a function of time. For several spectra, loudness numbers will be computed and tabulated. If it is possible, we would like to obtain data on variation of sound level with altitude and temperature in pressurized cabins.

The following flight data apply to the next six pages of graphs. The exhaust frequencies shown on these pages are the second and fourth harmonics. The fundamental and third harmonics were omitted and should be included.

Type Plane: B - 18A.

Motors: 2 - 9 cylinder Wright Cyclone.

Gear Ratio: 11:16, three blades.

Propeller Diameter: 11.5 feet.

Tip Separation: 8 3/8 inches.

Normal Cruising:

R. P. M. = 1850 M. P. = 27.5 inches H. P. = 636

Alt. = 7000 - 8000 ft. T = -20°C.

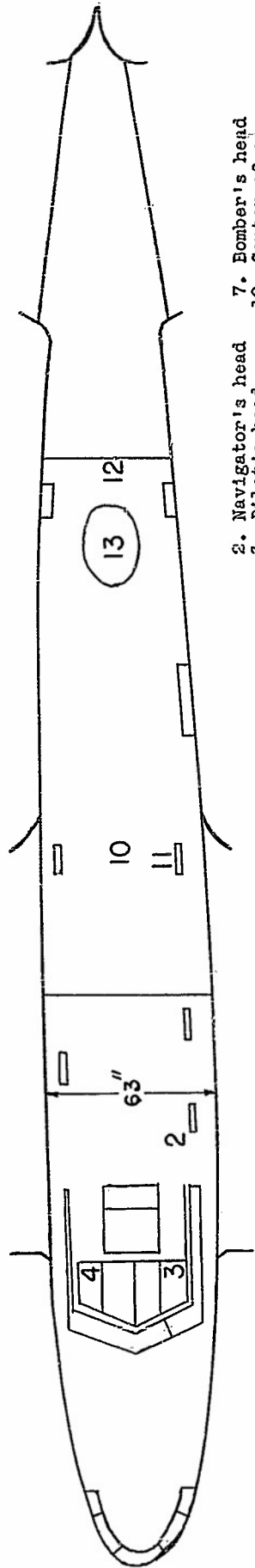

- 2. Navigator's head
- 3. Pilot's head
- 4. Co-pilot's head
- 5. Near floor
- 6. Turret
- 7. Bomber's head
- 10. Center of comp.
- 11. Window
- 12. Standing head high
- 13. Turret

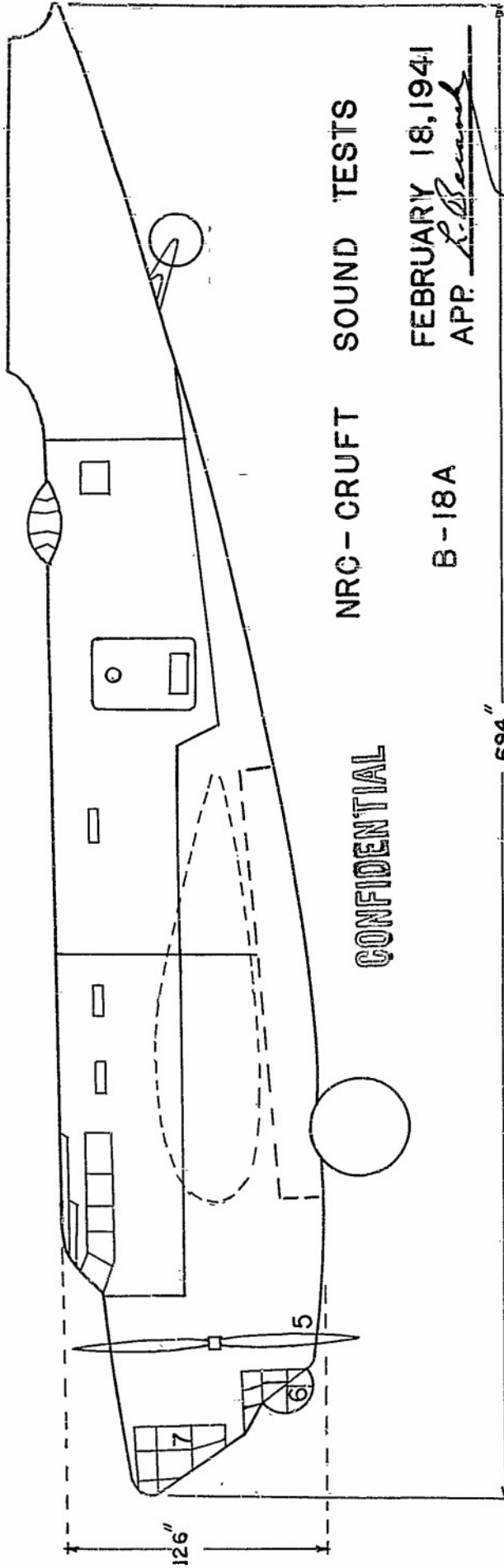

NRC - CRUFT SOUND TESTS

FEBRUARY 18, 1941

B-18A

APP. *L. Beard*

CONFIDENTIAL

694"

126"

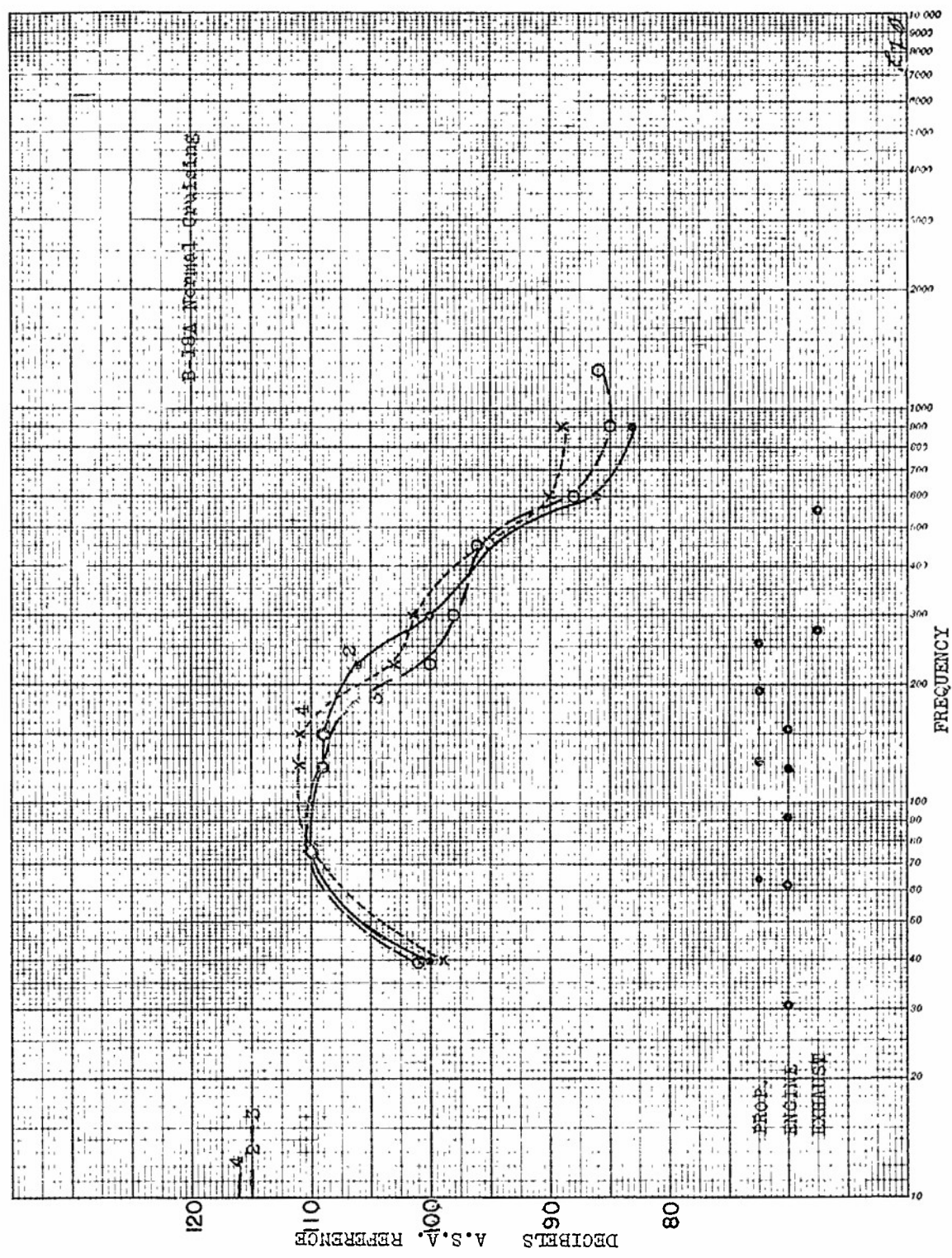

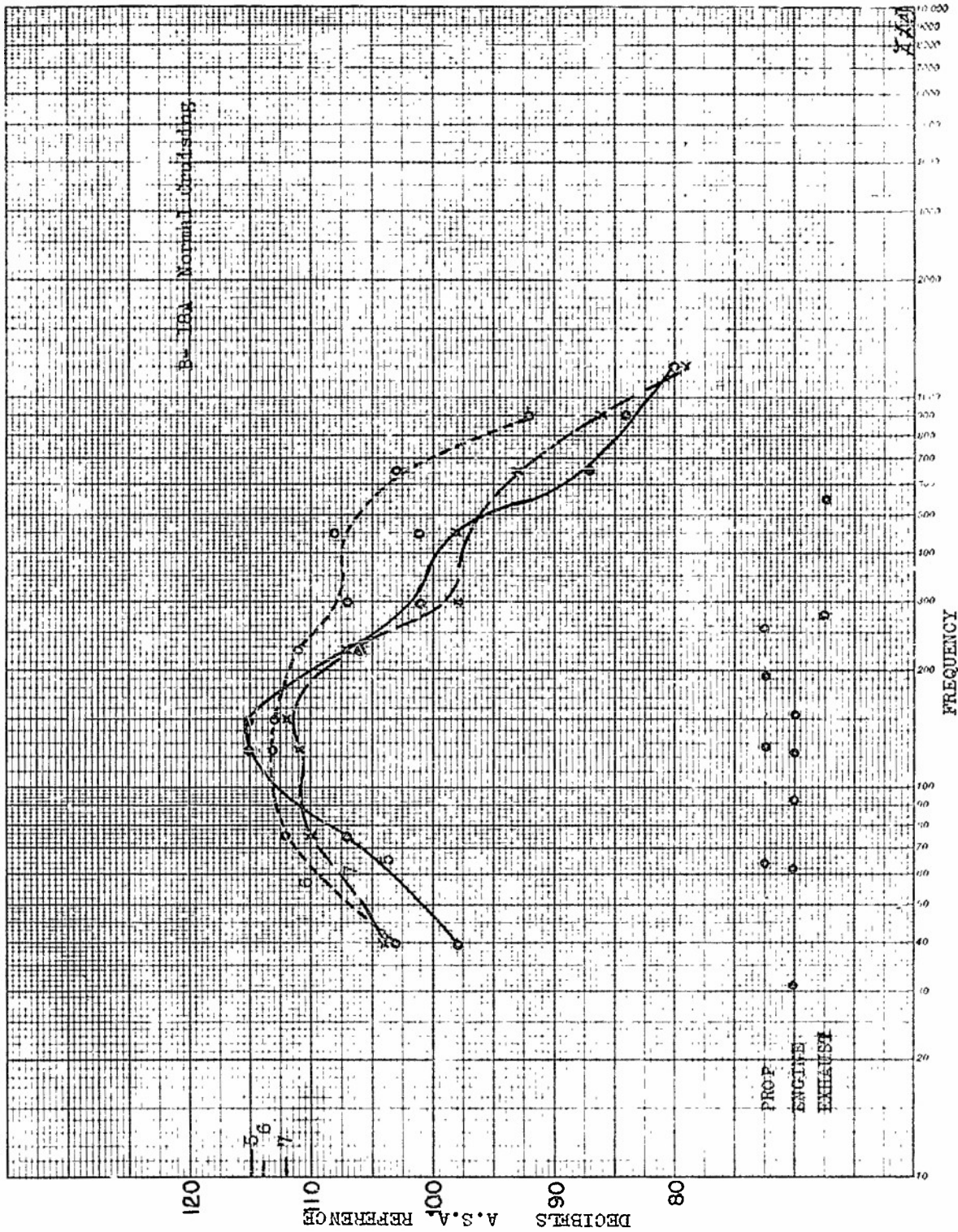

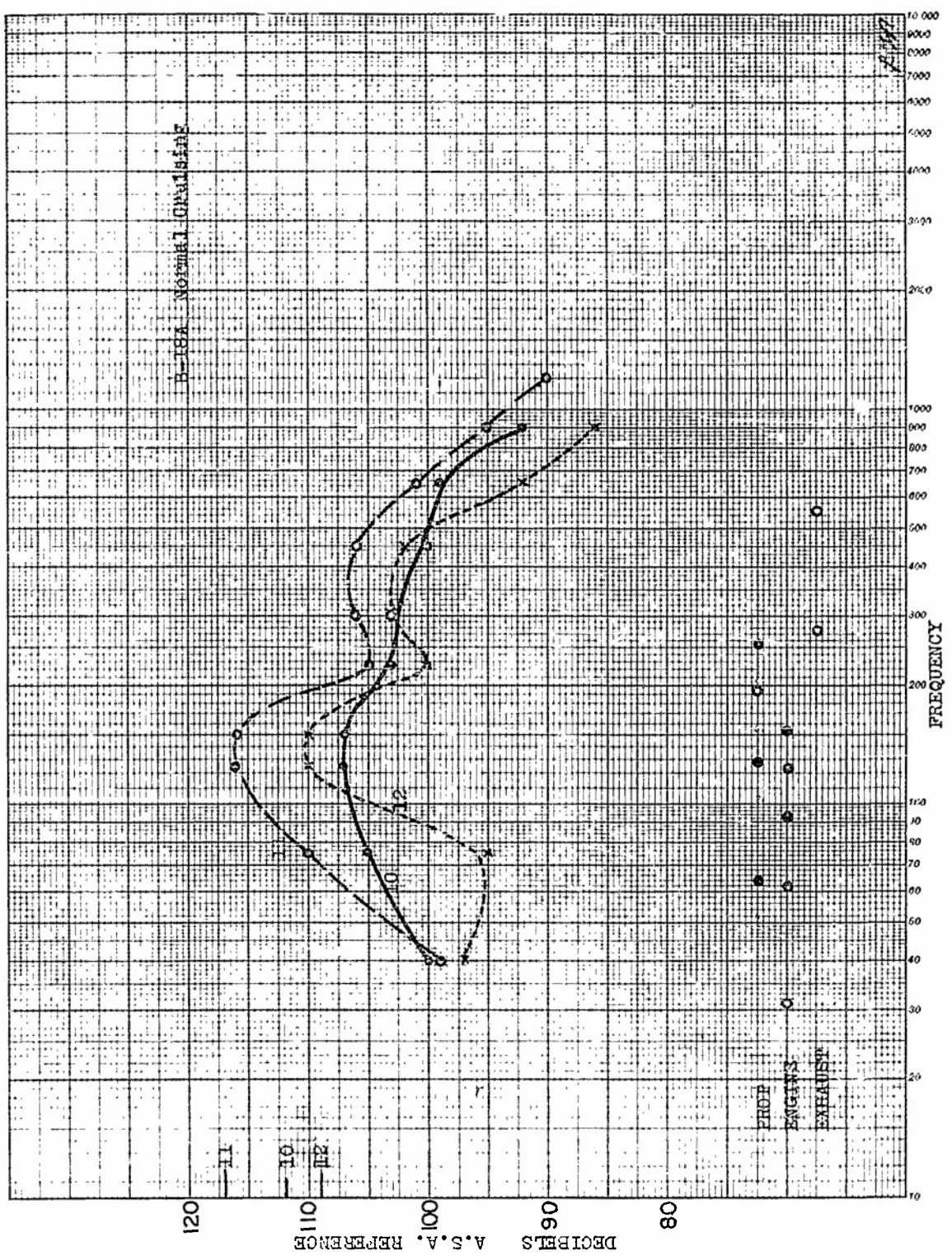

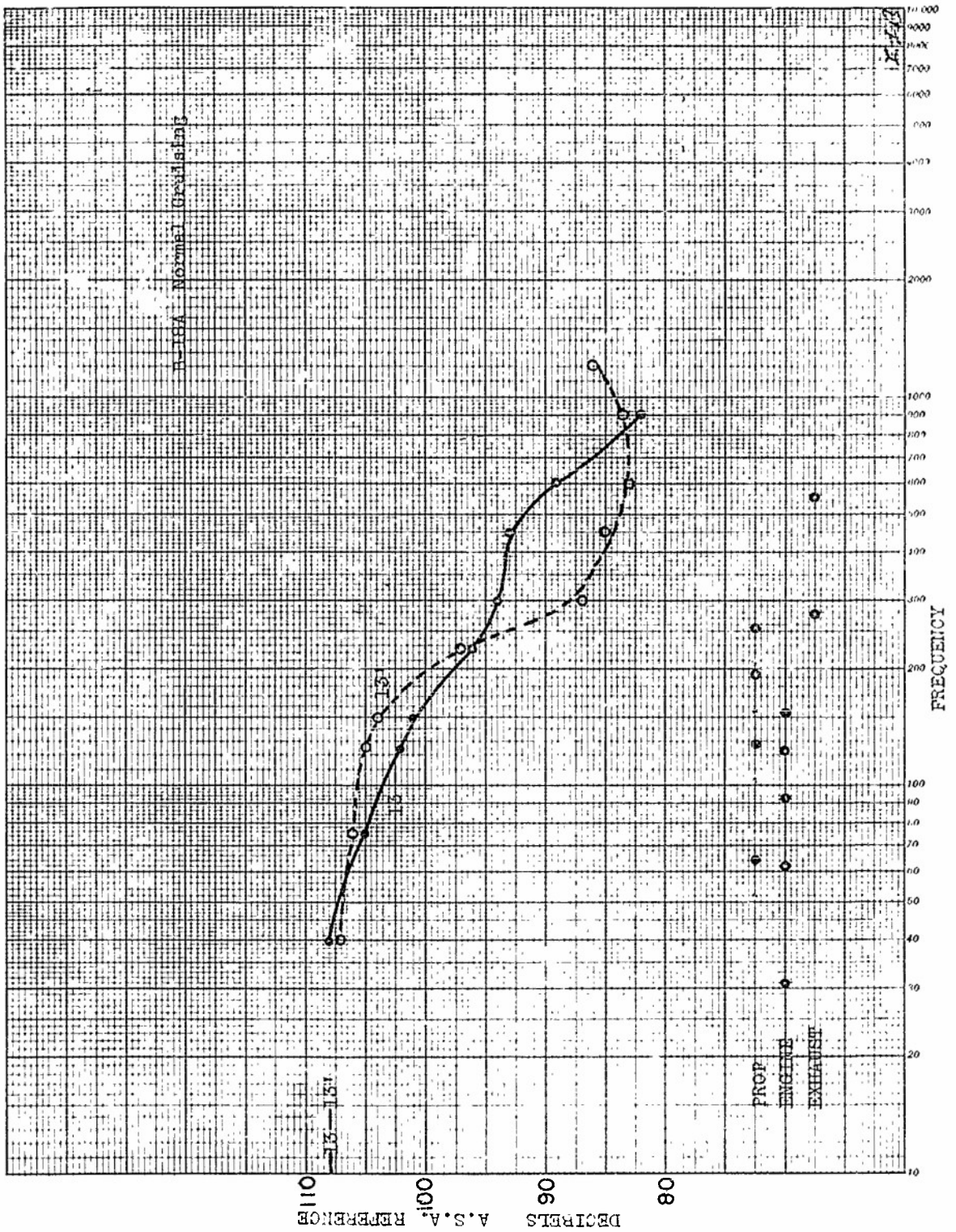

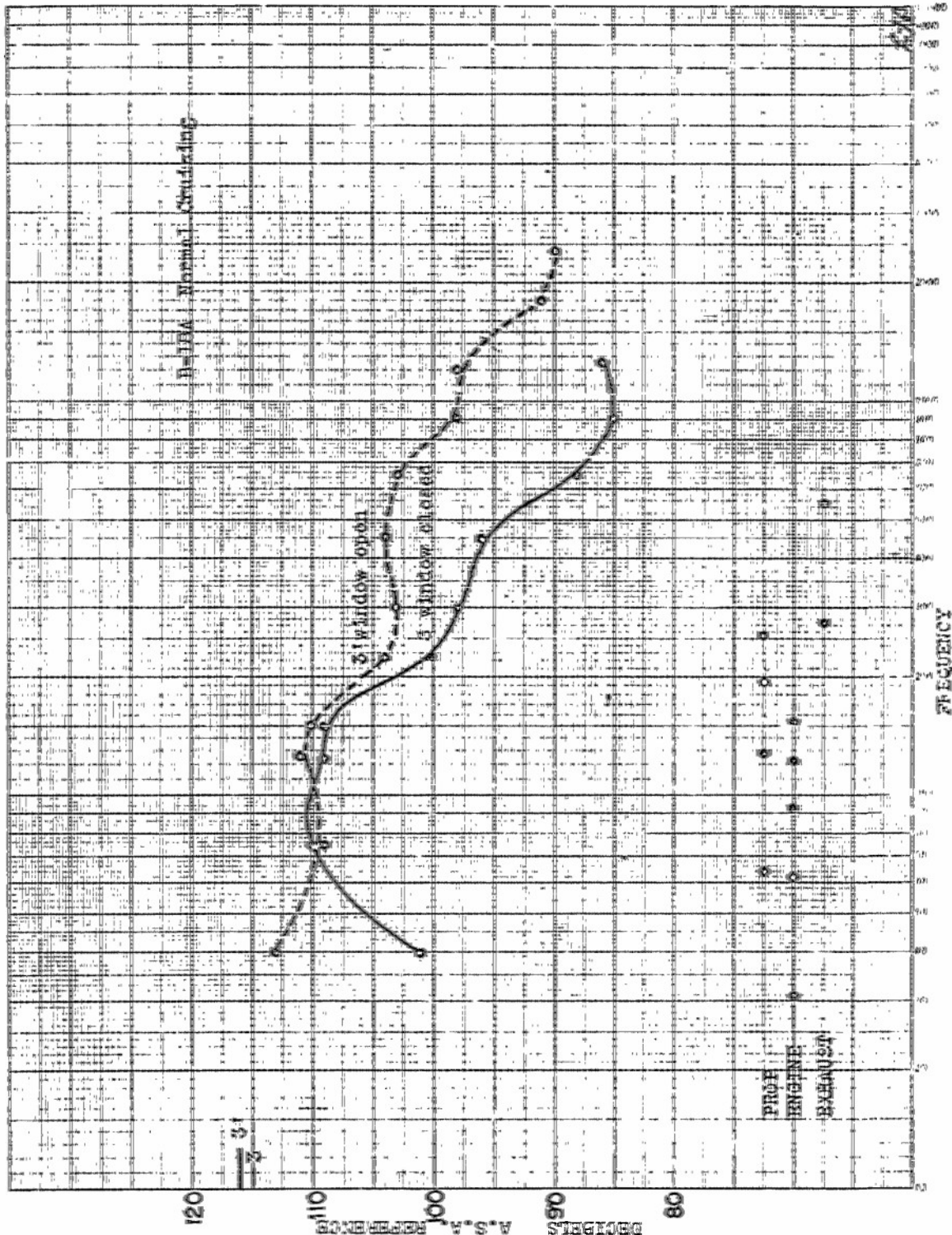

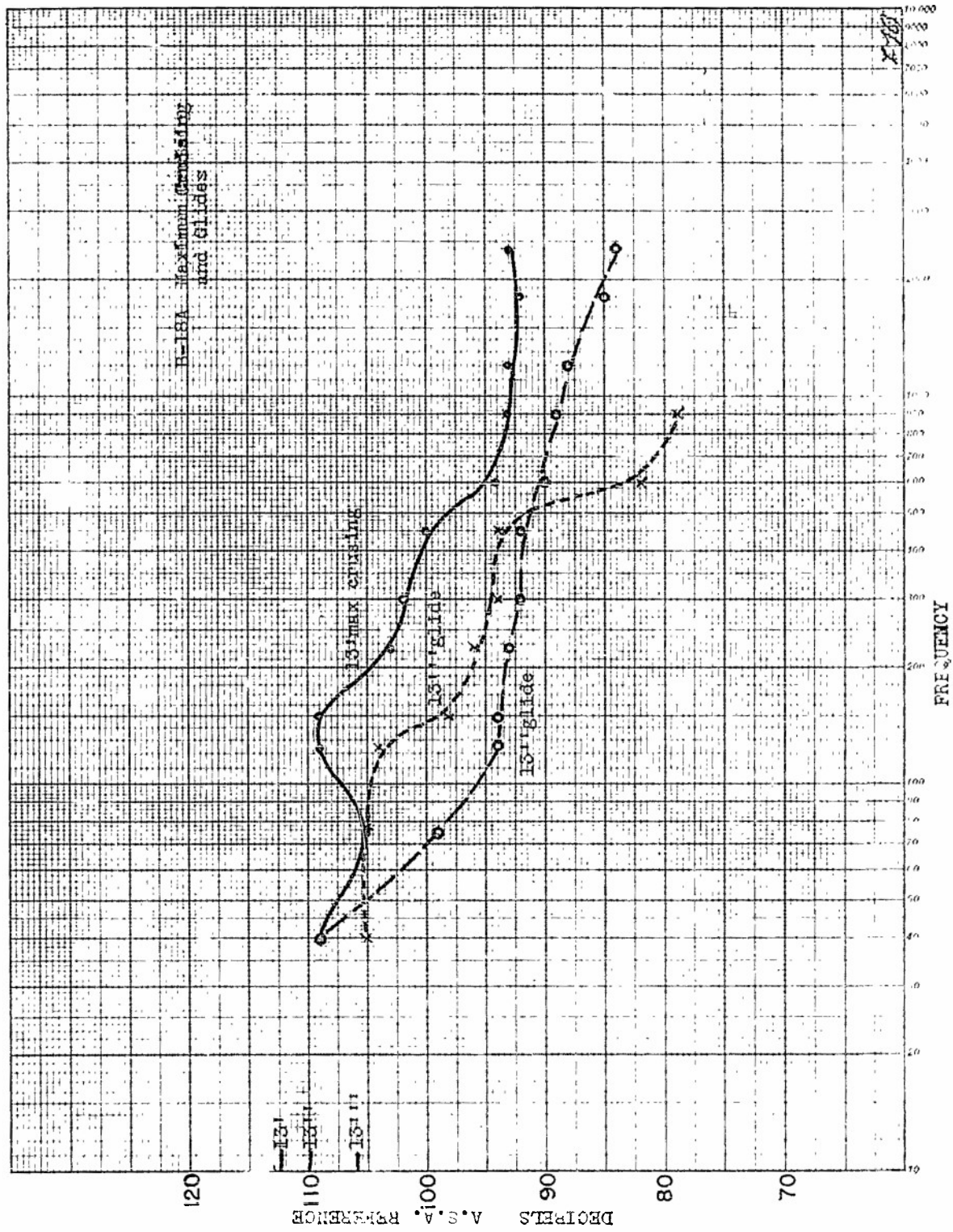

The following flight data apply to the next eight pages of graphs. The exhaust frequencies shown on these pages are the second and fourth harmonics. The fundamental and third harmonics were omitted and should be included.

Type Plane: B - 17C.

Motors: 4 - 9 cylinder Wright Cyclone.

Gear Ratio: 9:16, three blades.

Propeller Diameter: 11.5 ft.

Tip Separation: 10 inches.

Normal Cruising:

R. P. M. = 2000; M. P. = 52.8 in.; H. P. = 785.

C. A. S. = 239 mph.; T = -9°C.; Alt. = 9000 ft.

Maximum Cruising:

R. P. M. = 2300; M. P. = 36 in.; H. P. = 985.

C. A. S. = 251 mph.; T = -9°C.; Alt. = 9500 ft.

Economical Cruising:

R. P. M. = 1600; M. P. = 25 in.; H. P. = 495.

C. A. S. = 187 mph.; T = -10°C.; Alt. = 9500 ft.

C. A. S. = Corrected Air Speed.

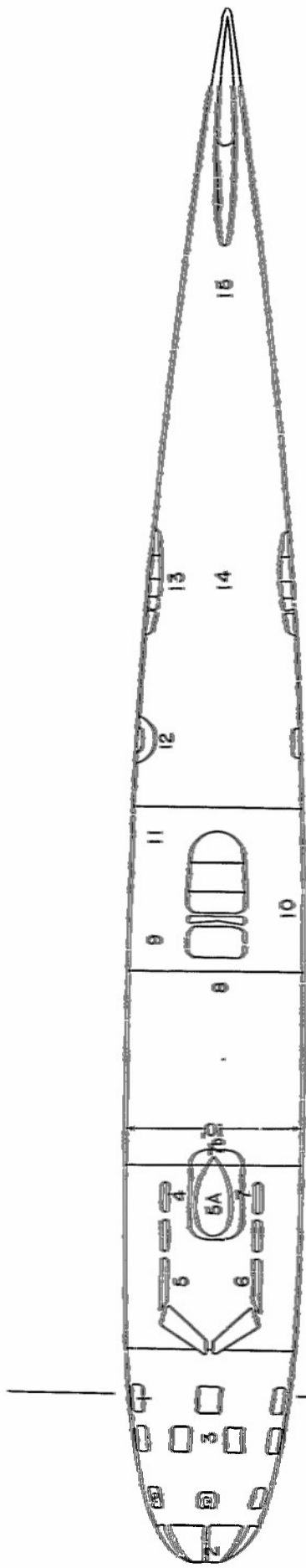

NRC - CRUFT
SOUND TESTS
B-17C

- 31 AIDE WISEWY
- 32 ASK-18 HEAD
- 33 ASK-18 HEAD
- 34 ASK-18 HEAD
- 35 ASK-18 HEAD
- 36 ASK-18 HEAD
- 37 ASK-18 HEAD
- 38 ASK-18 HEAD
- 39 ASK-18 HEAD
- 40 ASK-18 HEAD
- 41 ASK-18 HEAD
- 42 ASK-18 HEAD
- 43 ASK-18 HEAD
- 44 ASK-18 HEAD
- 45 ASK-18 HEAD
- 46 ASK-18 HEAD
- 47 ASK-18 HEAD
- 48 ASK-18 HEAD
- 49 ASK-18 HEAD
- 50 ASK-18 HEAD
- 51 ASK-18 HEAD
- 52 ASK-18 HEAD
- 53 ASK-18 HEAD
- 54 ASK-18 HEAD
- 55 ASK-18 HEAD
- 56 ASK-18 HEAD
- 57 ASK-18 HEAD
- 58 ASK-18 HEAD
- 59 ASK-18 HEAD
- 60 ASK-18 HEAD
- 61 ASK-18 HEAD
- 62 ASK-18 HEAD
- 63 ASK-18 HEAD
- 64 ASK-18 HEAD
- 65 ASK-18 HEAD
- 66 ASK-18 HEAD
- 67 ASK-18 HEAD
- 68 ASK-18 HEAD
- 69 ASK-18 HEAD
- 70 ASK-18 HEAD
- 71 ASK-18 HEAD
- 72 ASK-18 HEAD
- 73 ASK-18 HEAD
- 74 ASK-18 HEAD
- 75 ASK-18 HEAD
- 76 ASK-18 HEAD
- 77 ASK-18 HEAD
- 78 ASK-18 HEAD
- 79 ASK-18 HEAD
- 80 ASK-18 HEAD
- 81 ASK-18 HEAD
- 82 ASK-18 HEAD
- 83 ASK-18 HEAD
- 84 ASK-18 HEAD
- 85 ASK-18 HEAD
- 86 ASK-18 HEAD
- 87 ASK-18 HEAD
- 88 ASK-18 HEAD
- 89 ASK-18 HEAD
- 90 ASK-18 HEAD
- 91 ASK-18 HEAD
- 92 ASK-18 HEAD
- 93 ASK-18 HEAD
- 94 ASK-18 HEAD
- 95 ASK-18 HEAD
- 96 ASK-18 HEAD
- 97 ASK-18 HEAD
- 98 ASK-18 HEAD
- 99 ASK-18 HEAD
- 100 ASK-18 HEAD

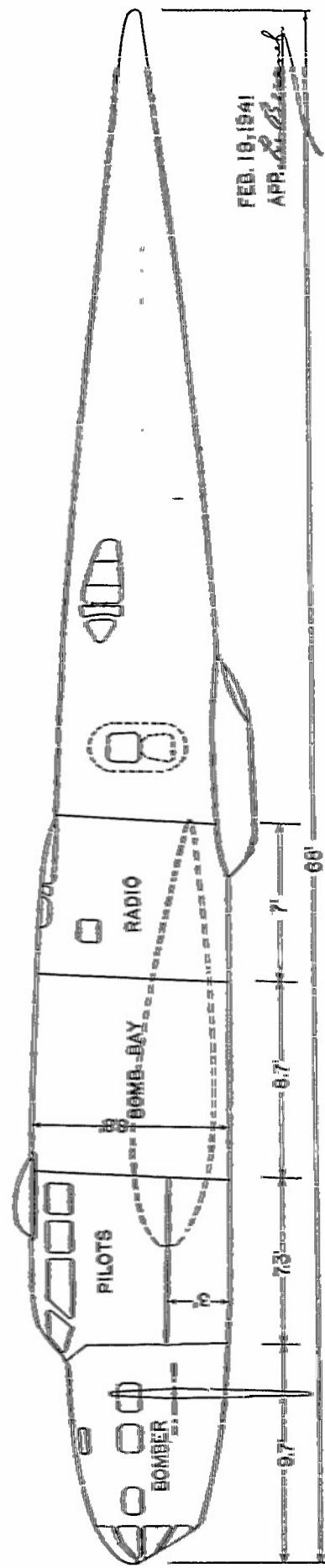

FEB. 10, 1941
APR. 1941

CONFIDENTIAL

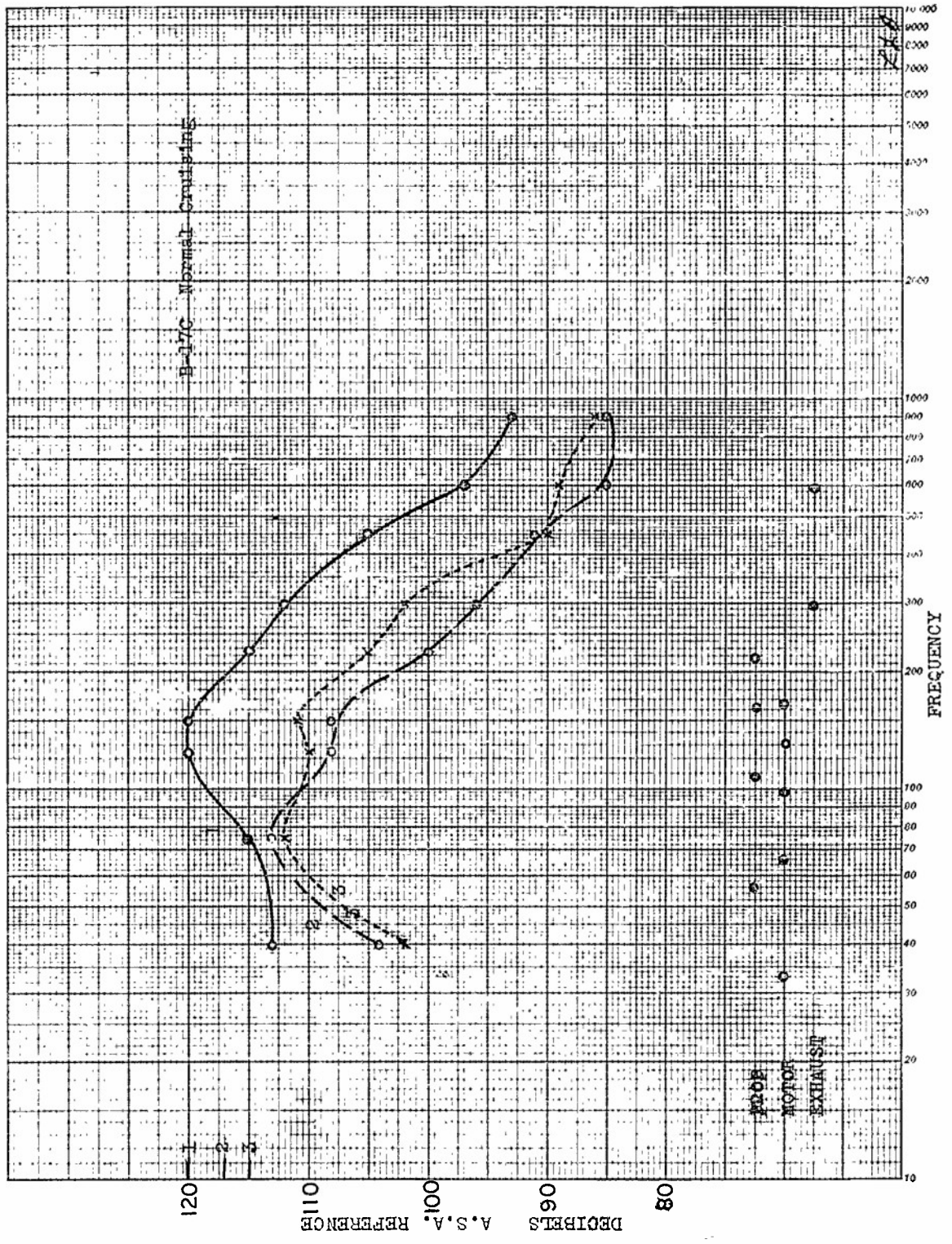

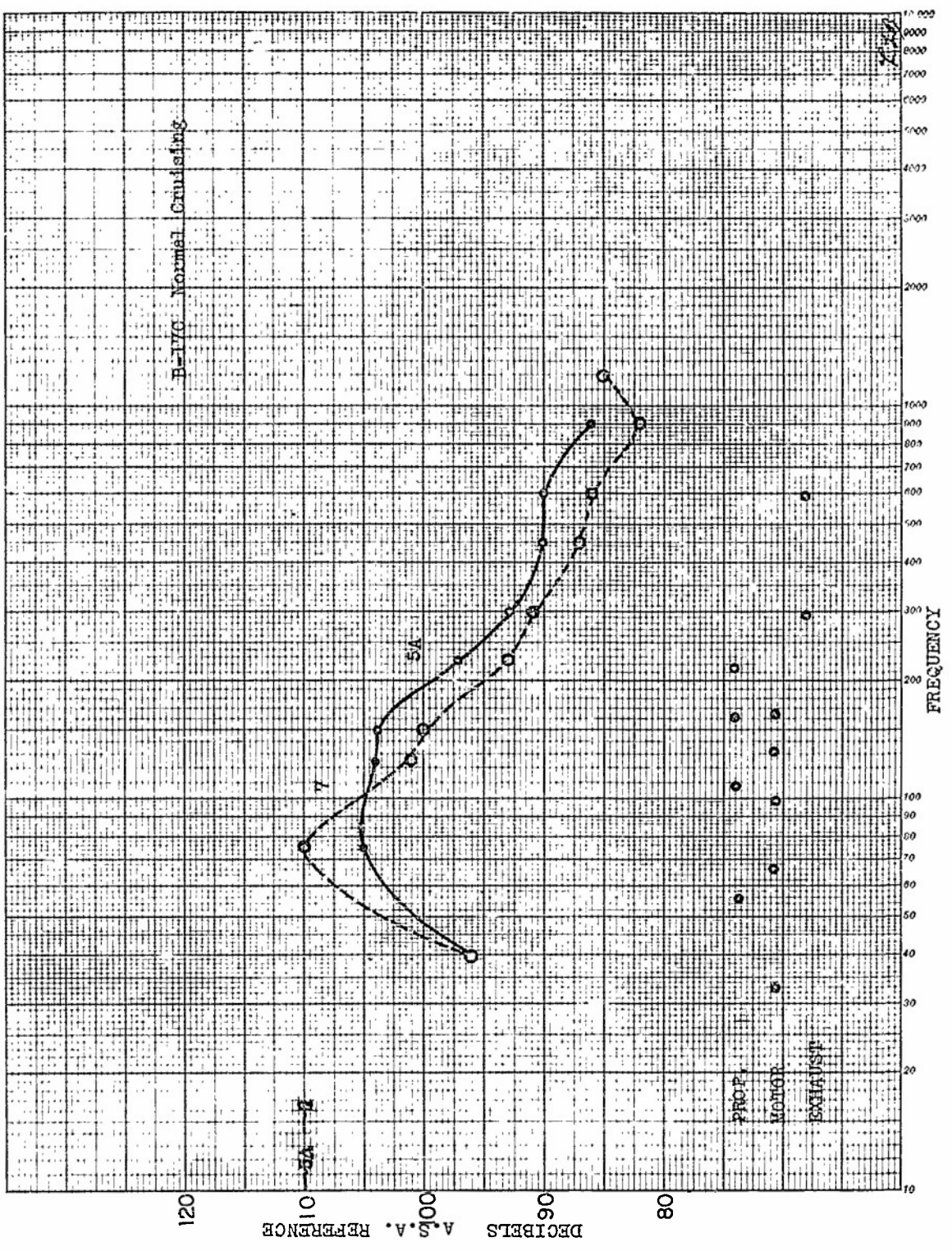

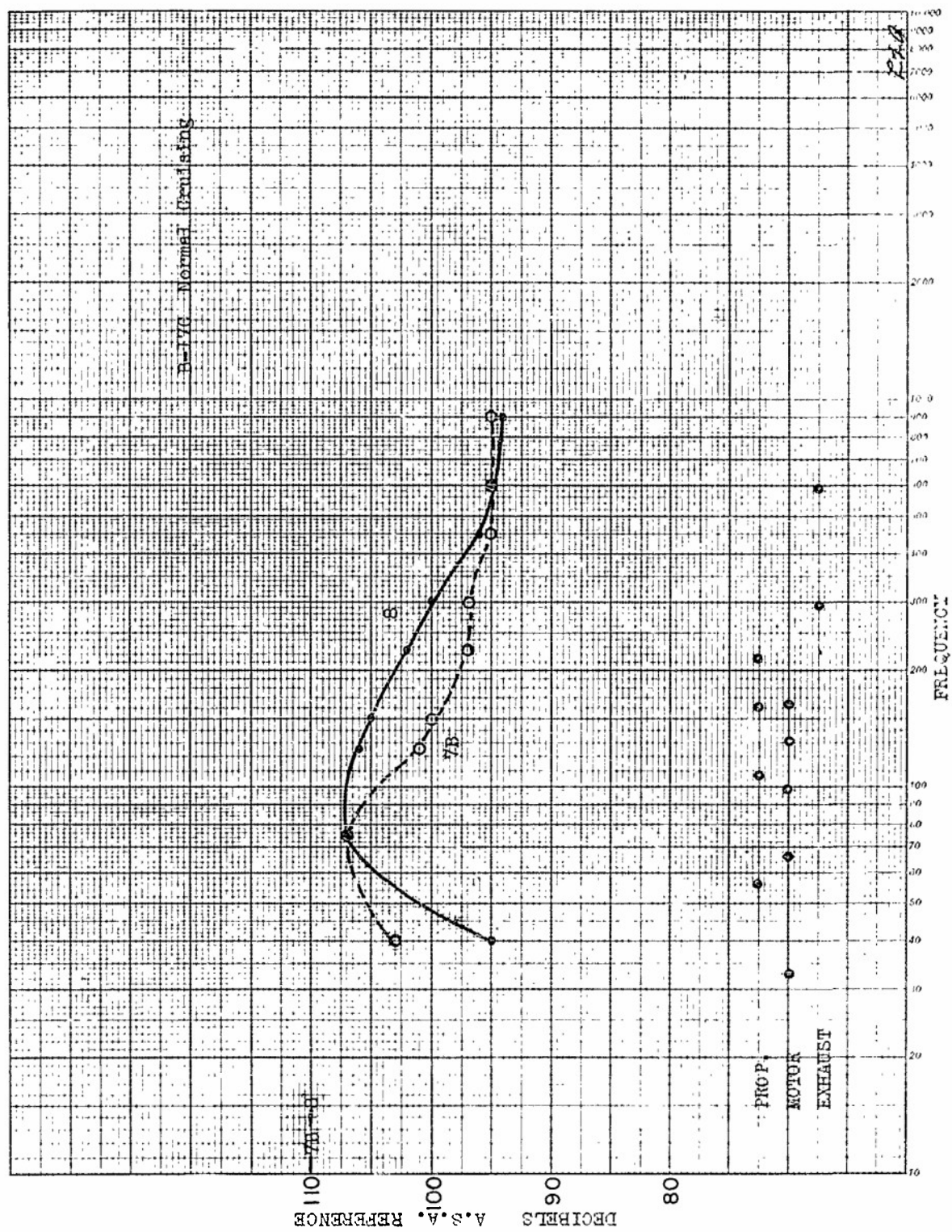

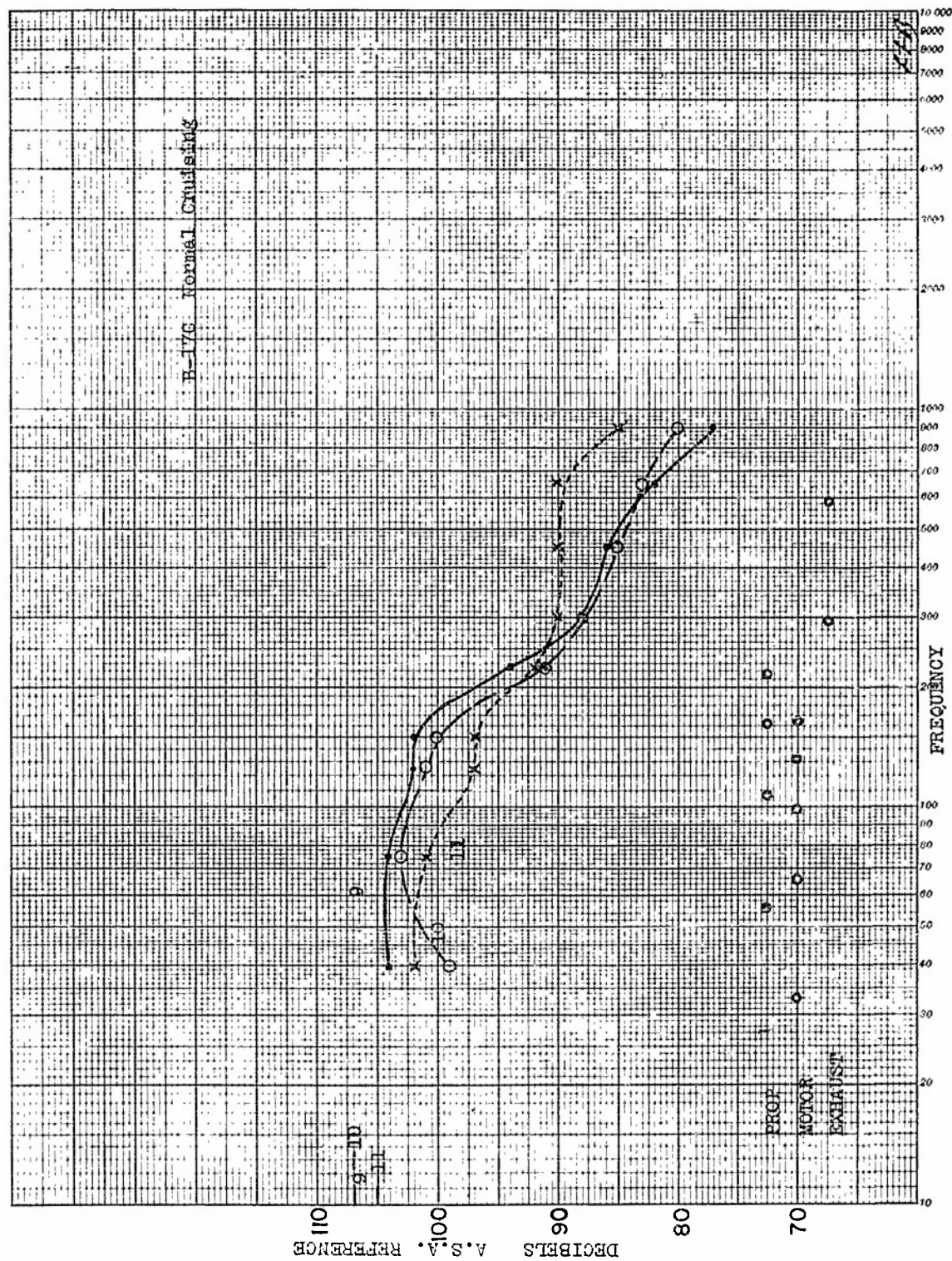

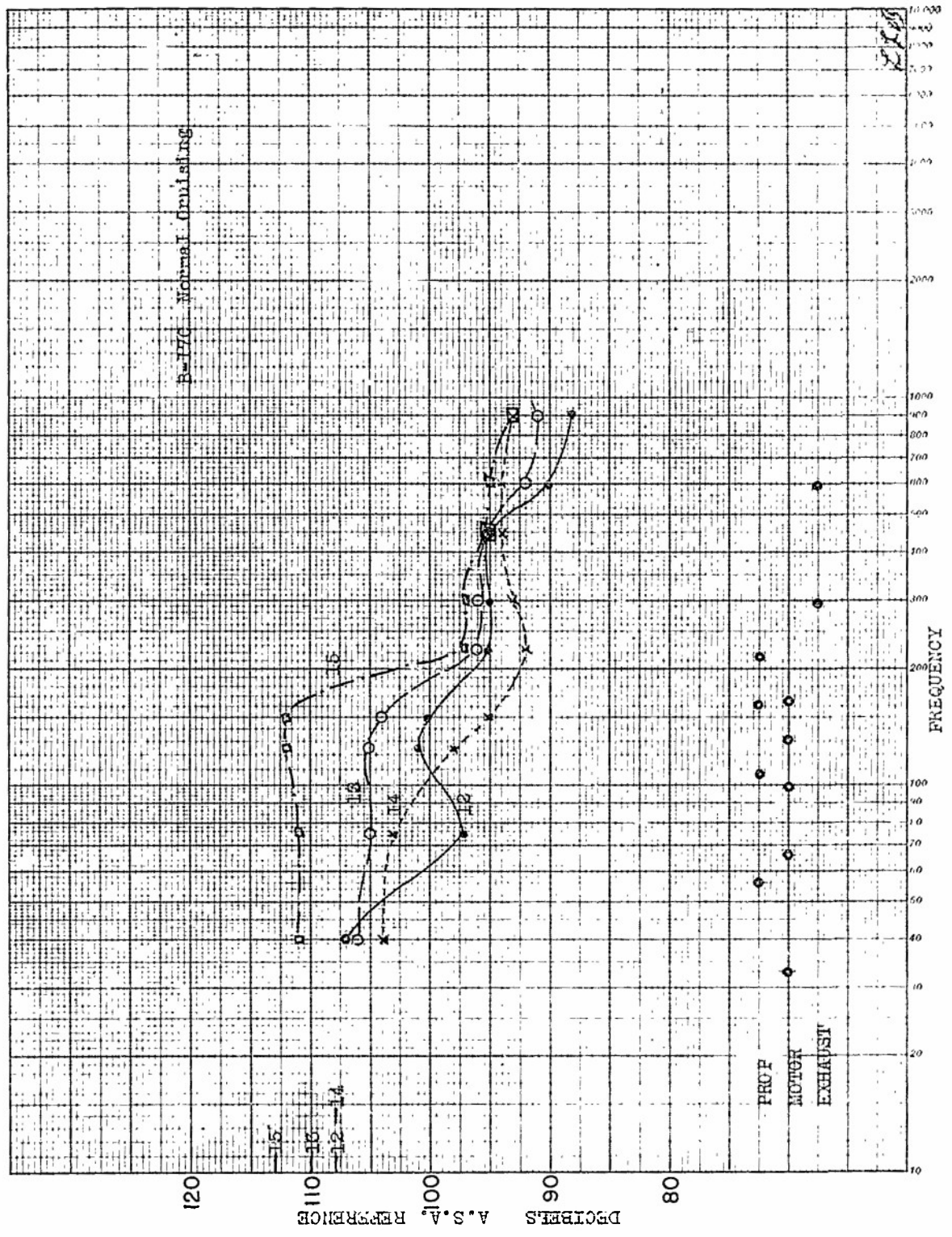

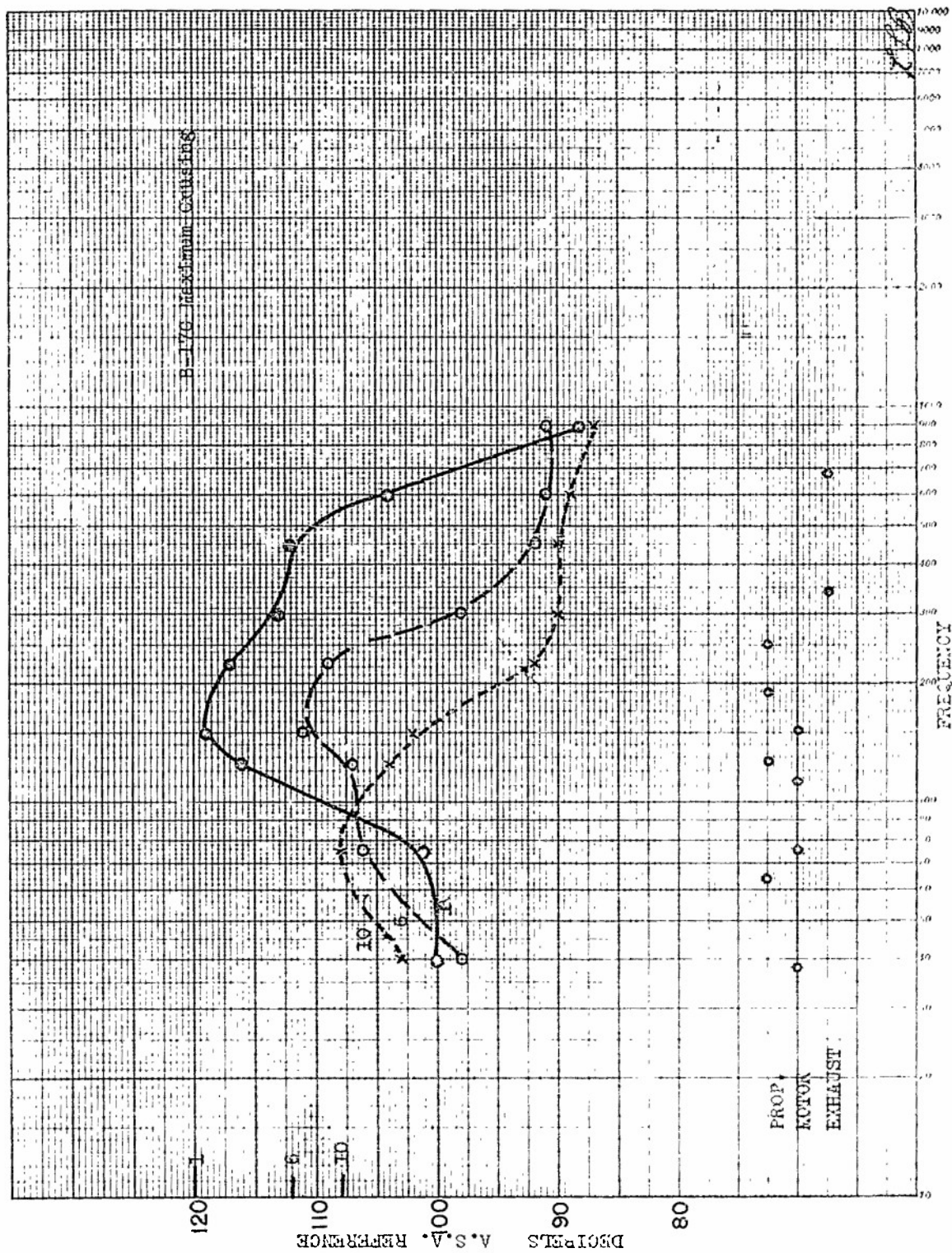

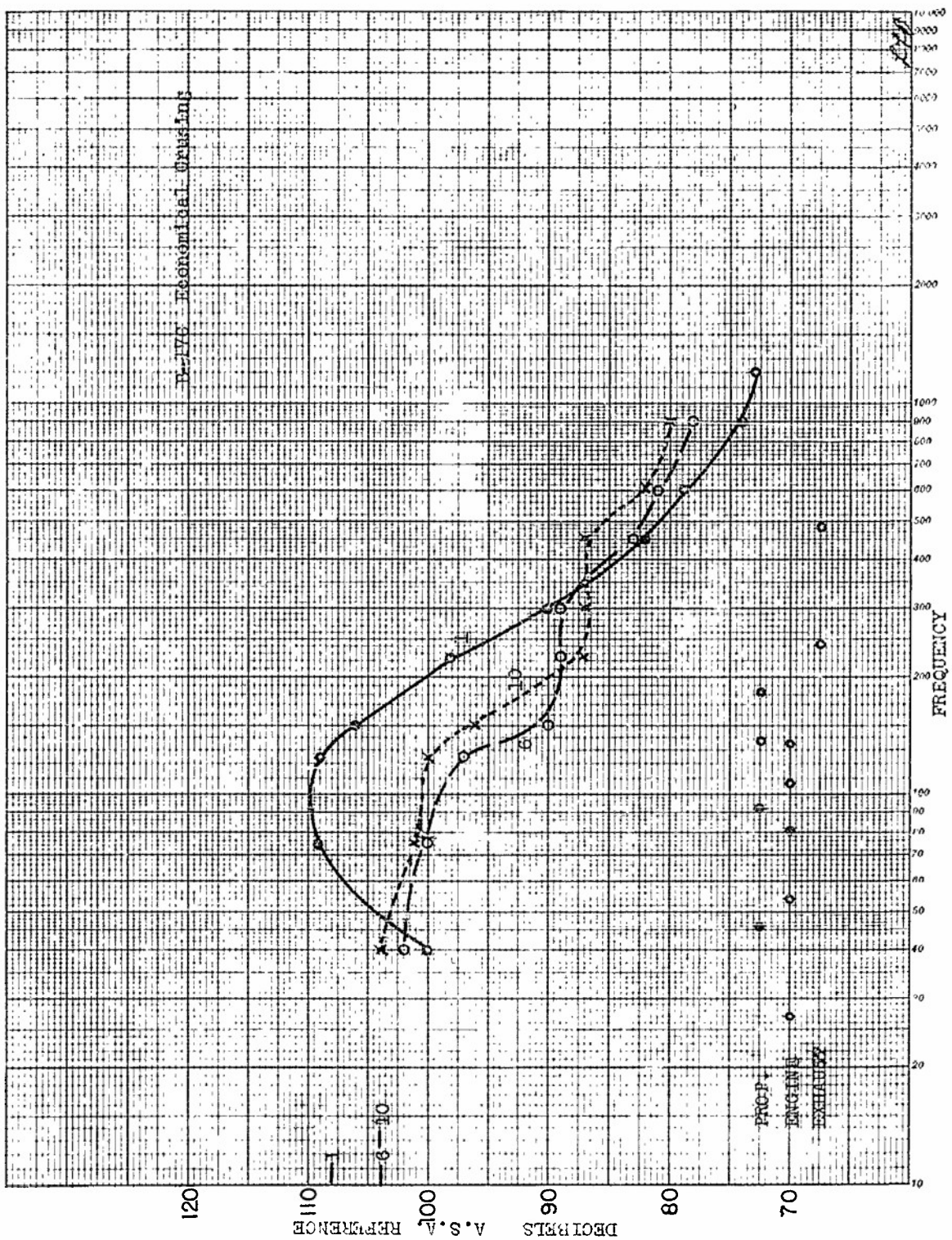

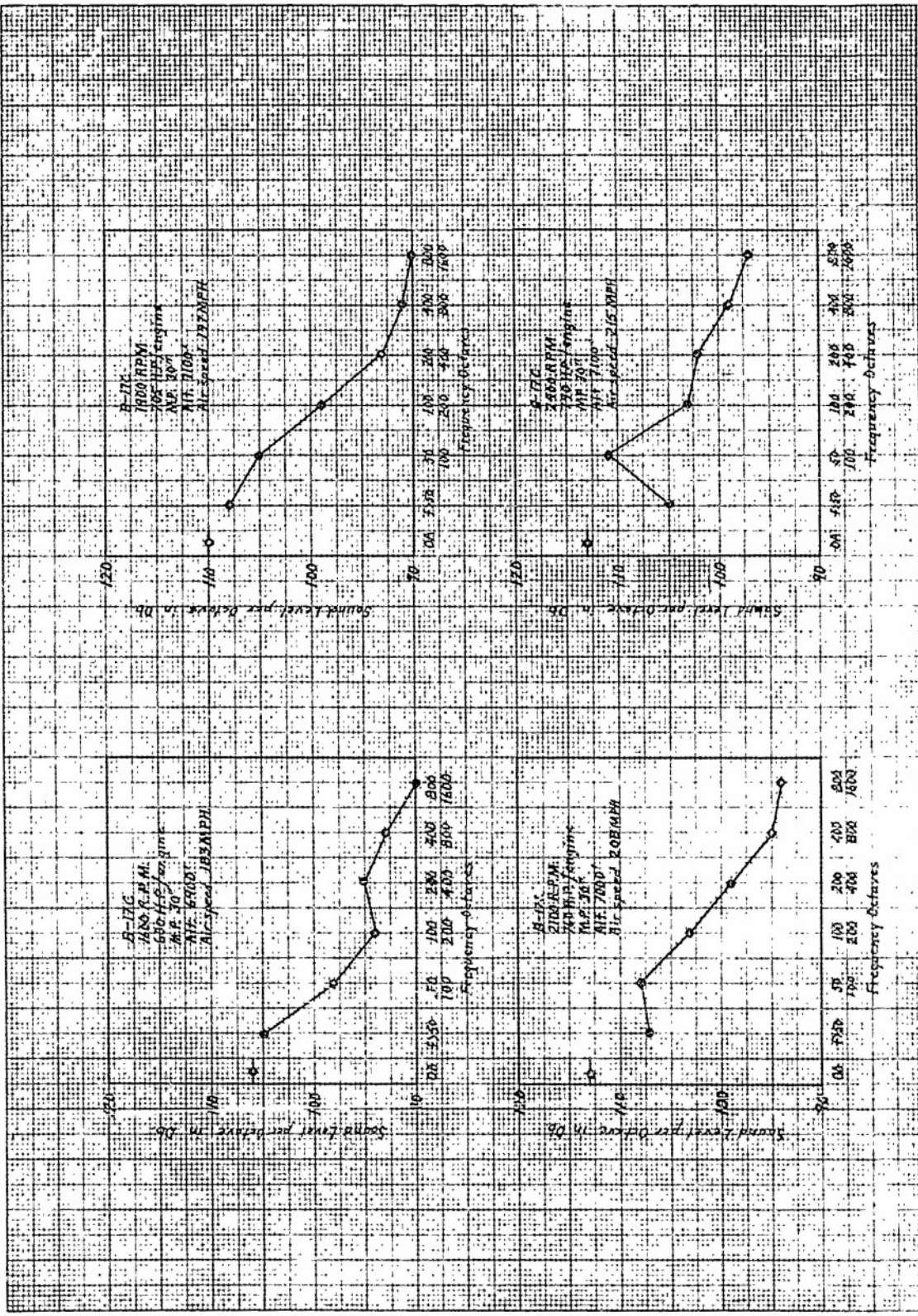

The following flight data apply to the next eight pages of graphs. The exhaust frequencies shown on these pages are the second and fourth harmonics. The fundamental and third harmonics were omitted and should be included.

Type Plane: XPBY - 5A.

Motors: 2 - 9 cylinder.

Gear Ratio: 3:2, three blades.

Propeller Diameter: 12 feet.

Tip Separation: 10 inches.

Normal Cruising:

R. P. M. = 2150; M. P. = 25.5 in.; H. P. = 800.

I. A. S. = 110 nmph; T = 1°C.; Alt. = 2900 ft.

Maximum Cruising:

R. P. M. = 2500; M. P. = 35 in.; H. P. = 950.

I. A. S. = 130 nmph; T = -1°C.; Alt. = 4000 ft.

I. A. S. = Indicated Air Speed.

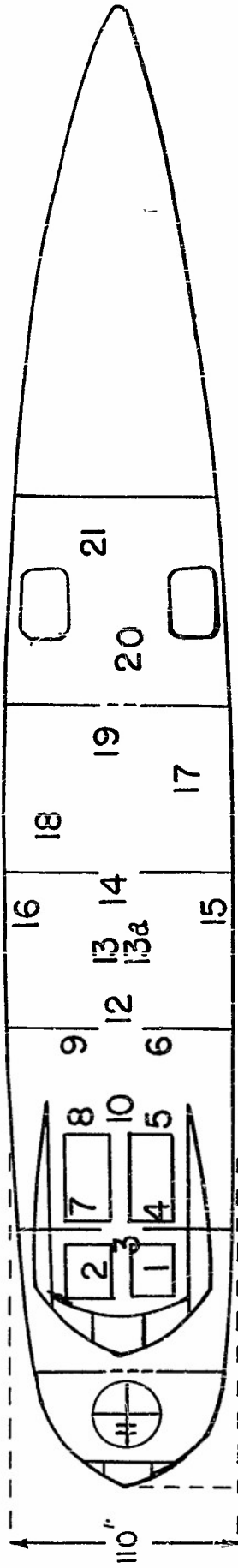

1. Pilot-head high
2. Co-pilot-head high
3. Standing head high
4. 3 inches from window
5. Standing head high
6. Standing head high
7. 3 inches from window
8. Standing head high
9. Standing head high
10. Standing head high
11. Standing head high
12. Standing head high
13. Standing head high
14. Standing head high
15. Low, by wheel
16. Low, by wheel
17. Edge of upper bunk
18. High and 3" in front of ventilator
19. Sitting head high
20. Sitting head high
21. Sitting head high

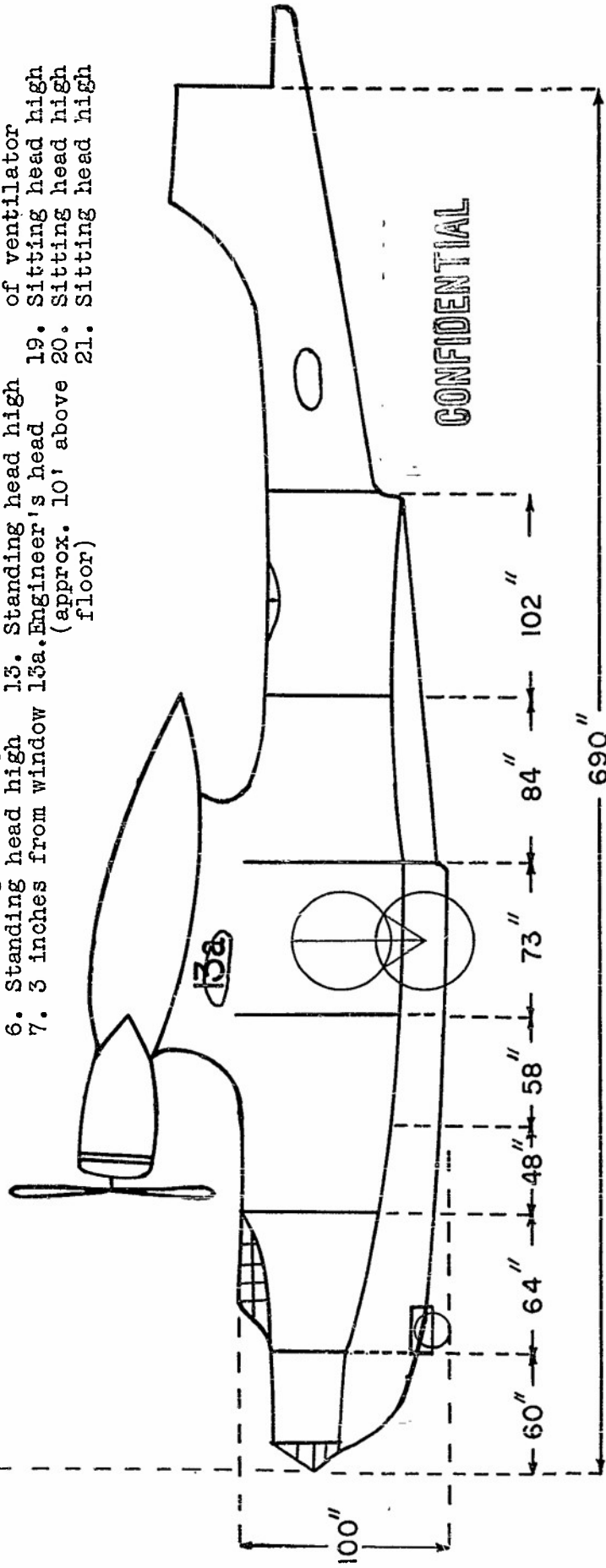

NRC - CRUFT SOUND TESTS MARCH 17, 1941

XPBY-5A

APP. *L. Beach*

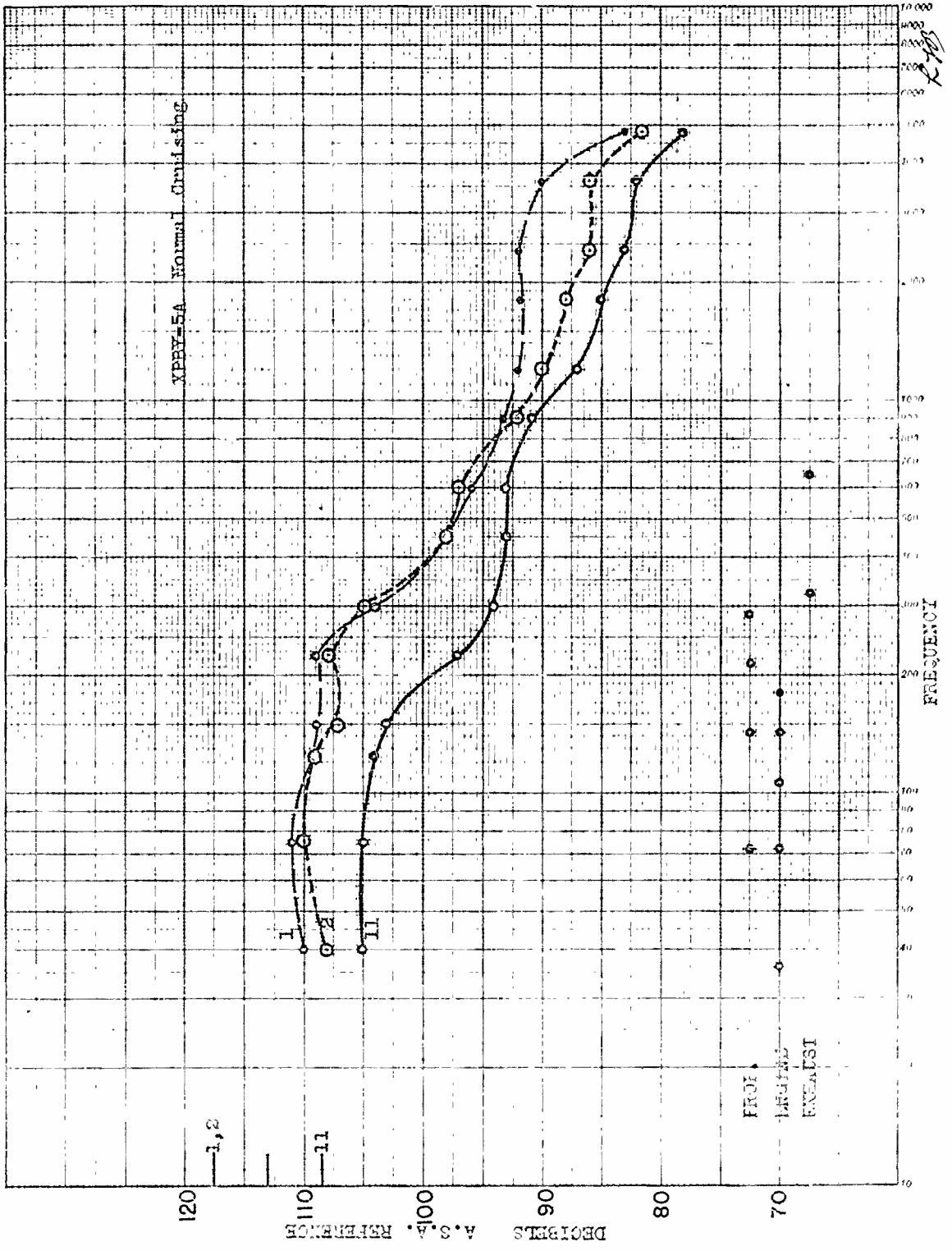

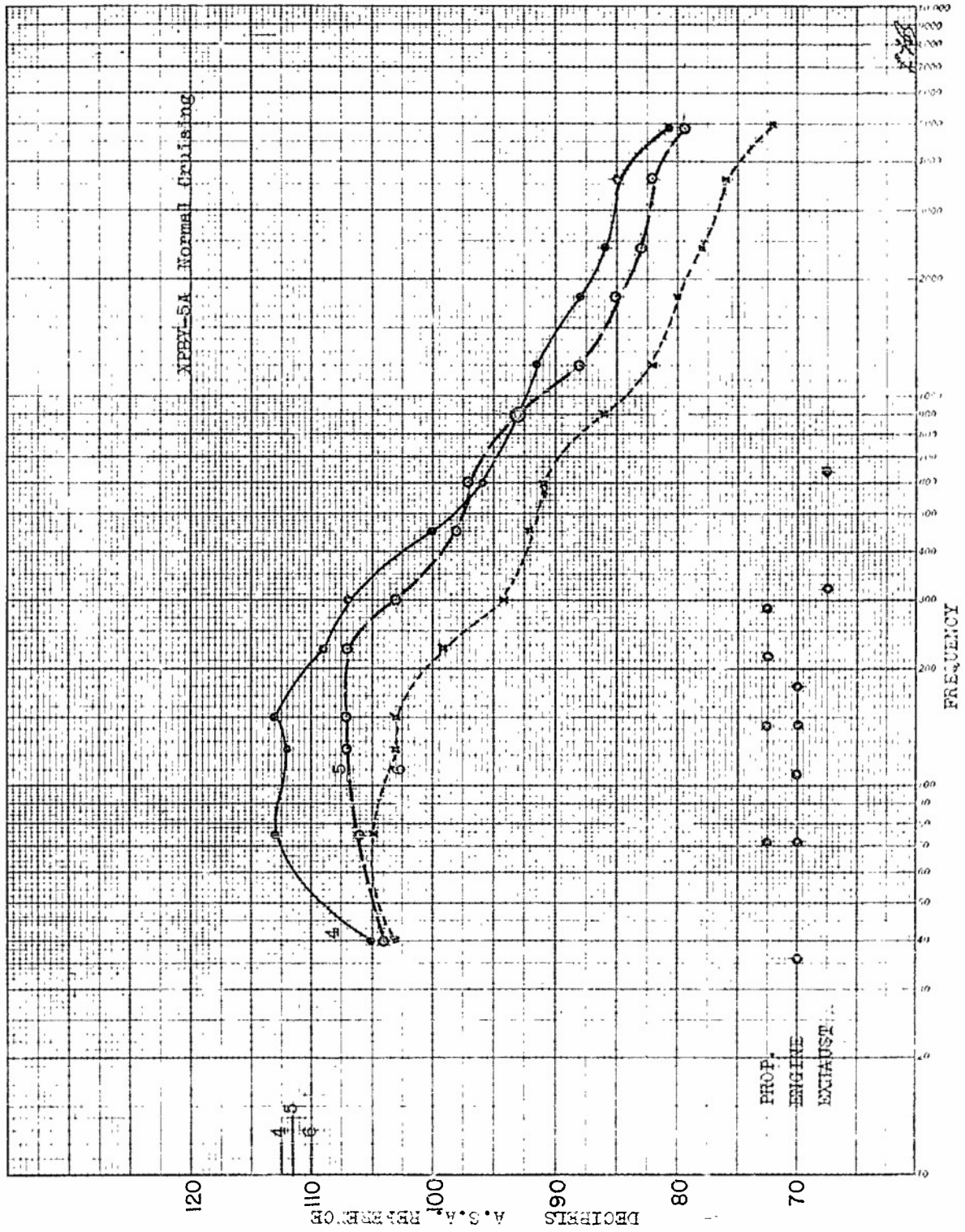

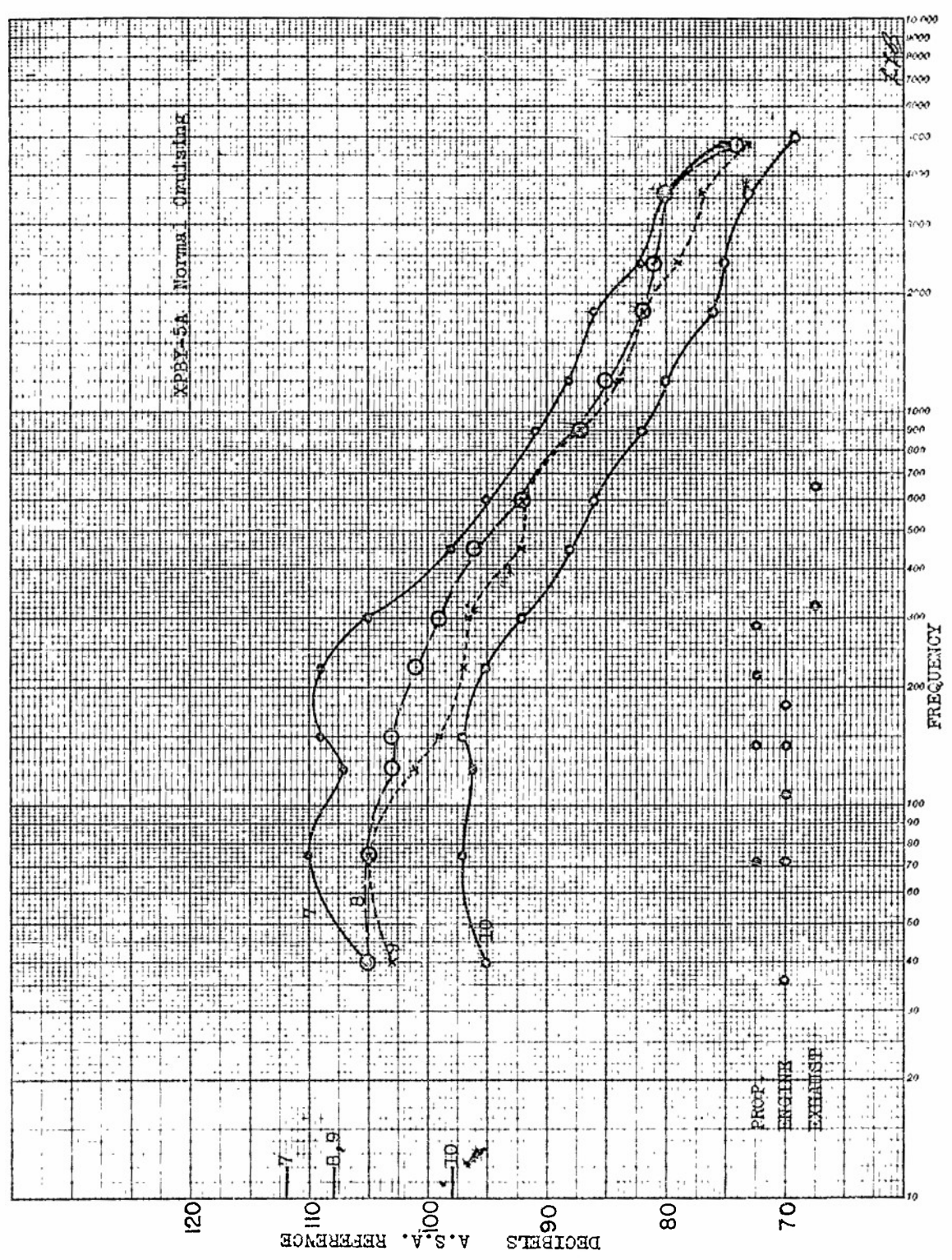

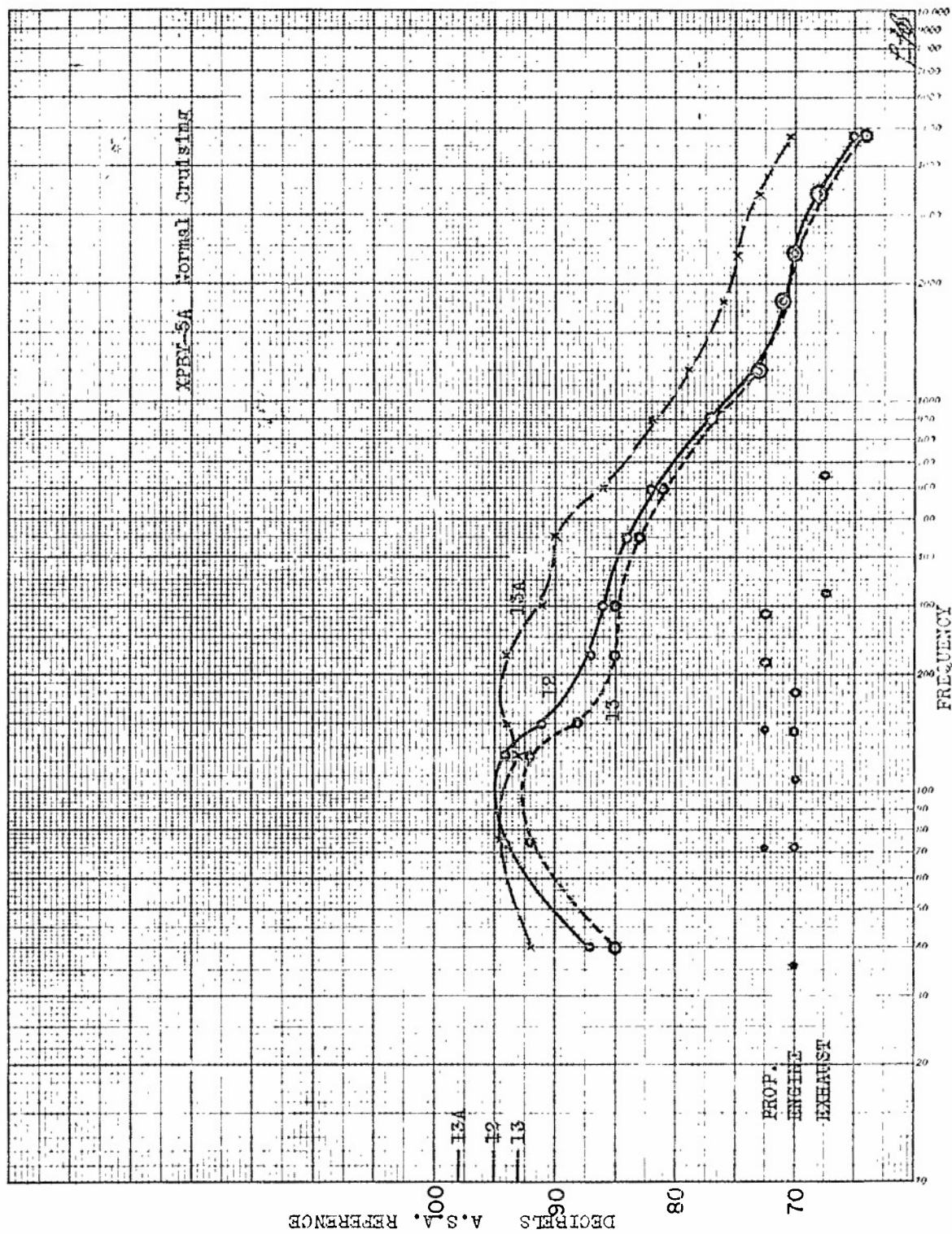

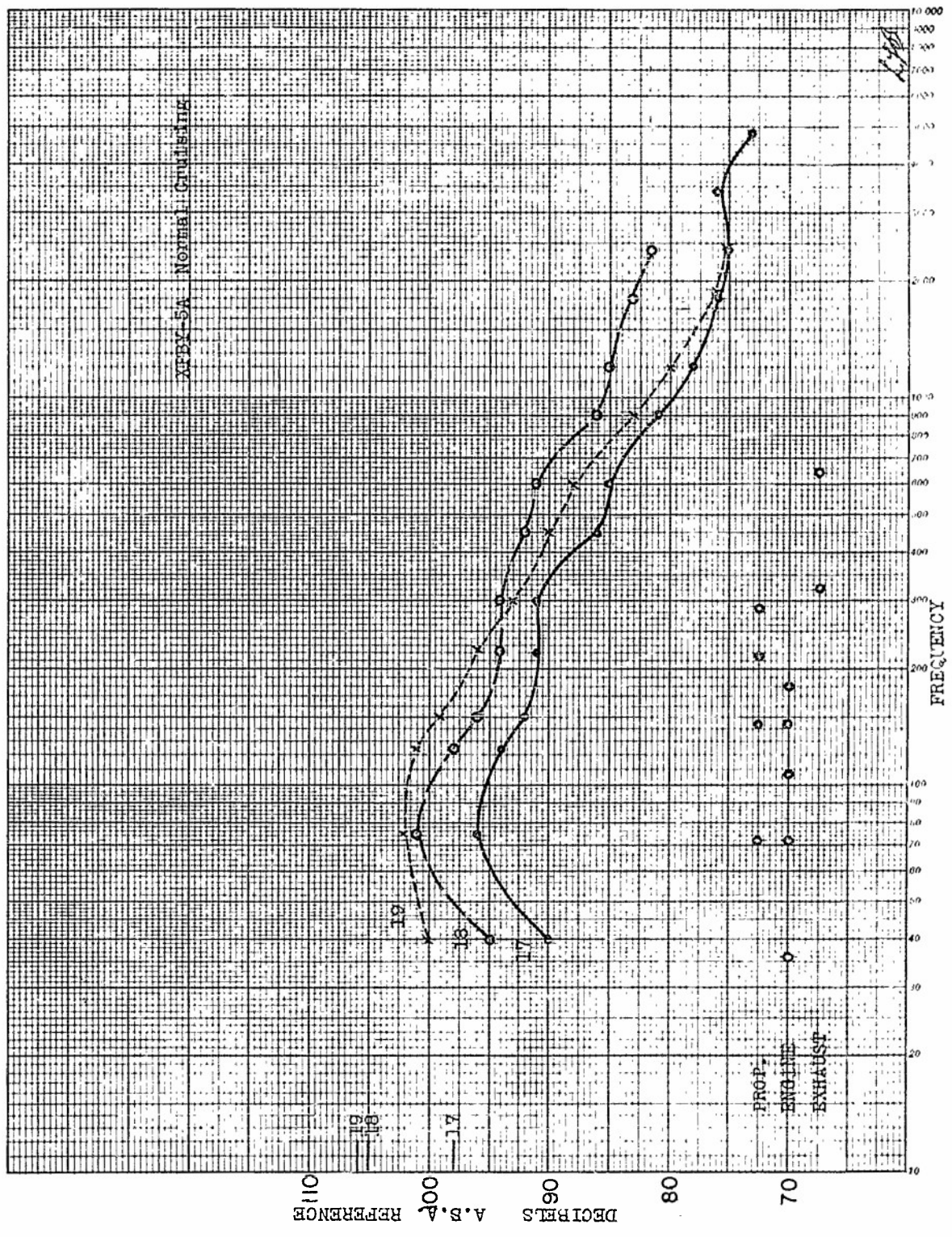

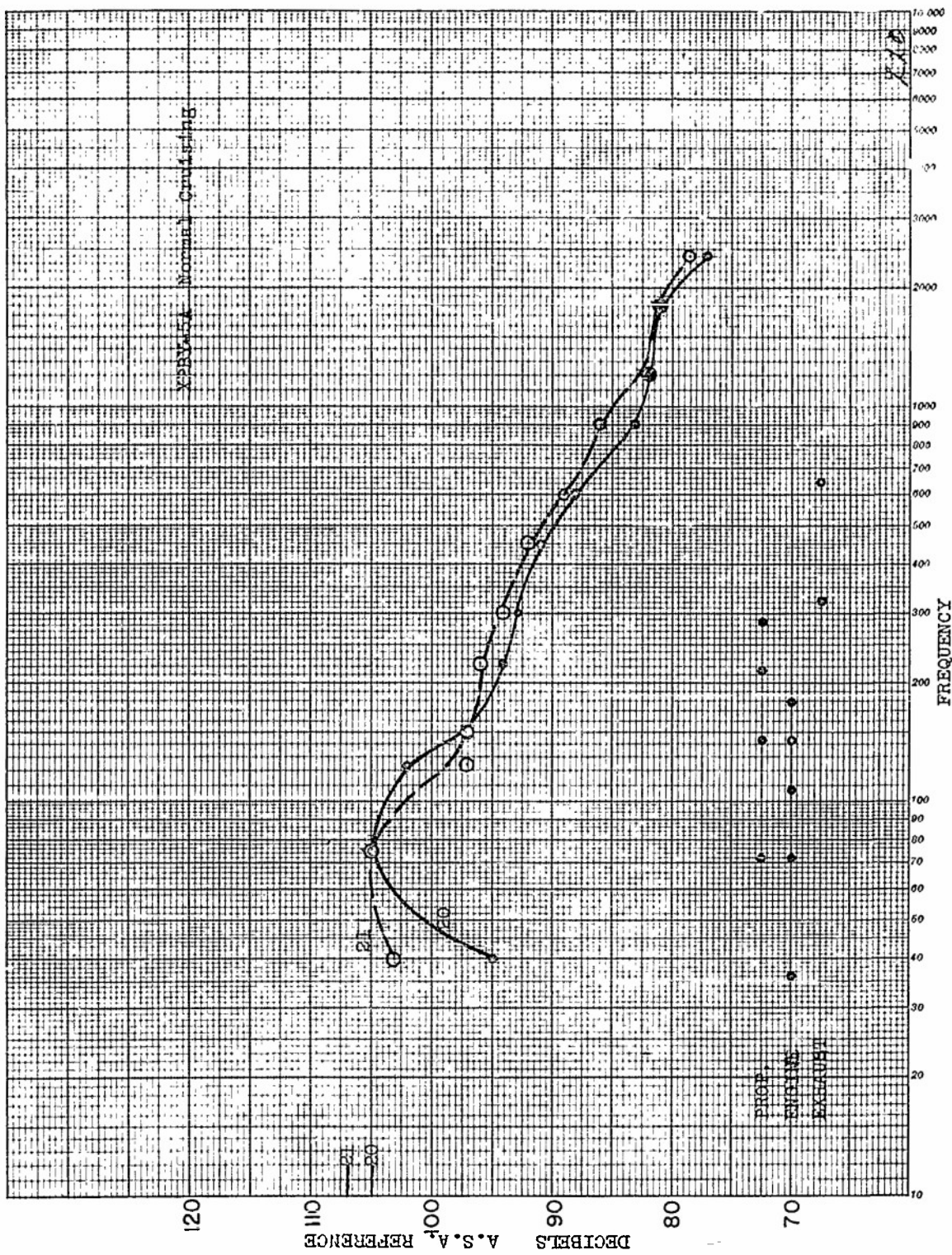

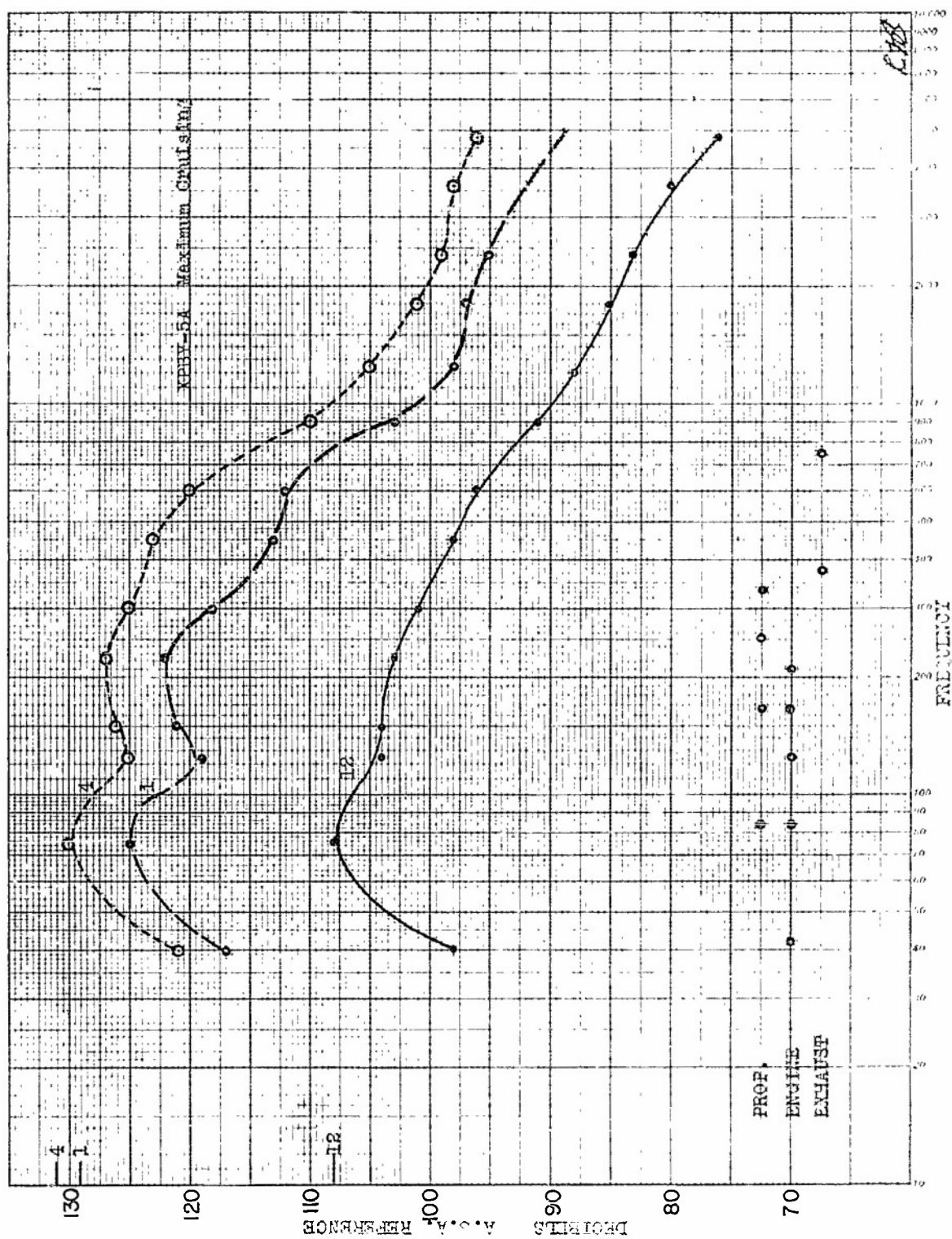

The following flight data apply to the next eight pages of graphs. The exhaust frequencies shown on these pages are the second and fourth harmonics. The fundamental and third harmonics were omitted and should be included.

Type Plane: PBM - 1.

Motors: 2 - 14 cylinder (alternate firing).

Gear Ratio: 9:16, three blades.

Propeller Diameter: 14.5 feet.

Tip Separation: 17.5 inches.

Normal Cruising:

R. P. M. = 1700; M. P. = 24 in.; H. P. = 750.

I. A. S. = 130 nmph.; T = -4°C.; Alt. = 5000 ft.

Maximum Cruising:

R. P. M. = 1900; M. P. = 27 in.; H. P. = 900.

I. A. S. = 150 nmph.; T = -5°C.; Alt. = 5000 ft.

I. A. S. = Indicated Air Speed.

- 1. Pilot's head
- 2. Co-pilot's head
- 3. Sitting head high
- 4. Navigator's head
- 5. Window (upper deck)
- 6. Engineer's head
- 7. Window
- 8. Window
- 11. Standing head (aisle)
- 12. Upper bunk
- 13. Upper bunk
- 14. Standing head high
- 15. Upper bunk
- 16. Standing head high
- 17. Sitting head high

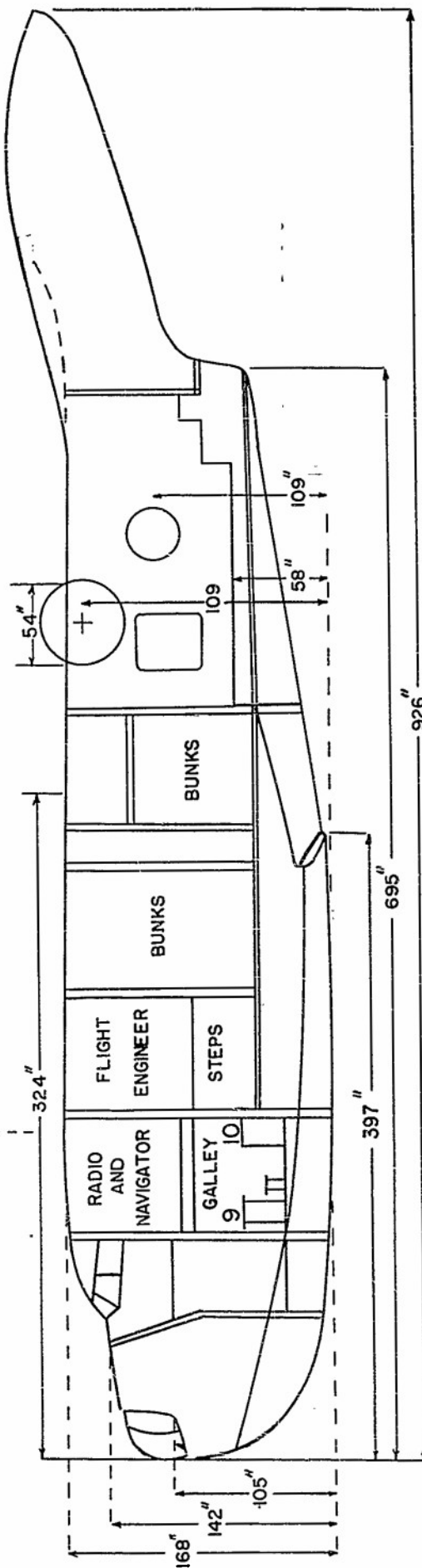
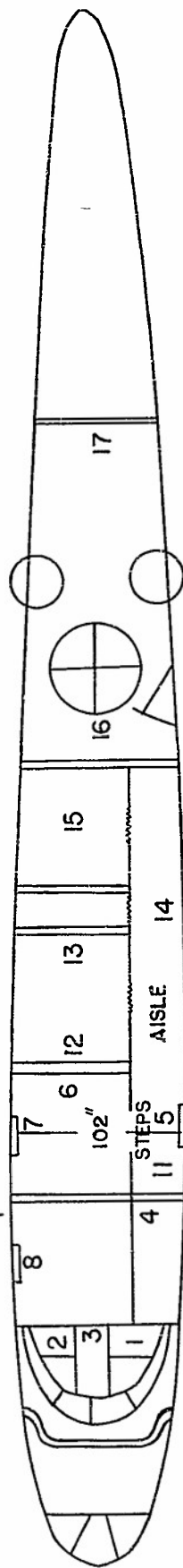

NRC - CRUFT SOUND TESTS CONFIDENTIAL
 PBM-1 MARCH 18, 1941
 APP. *L. Bunch*

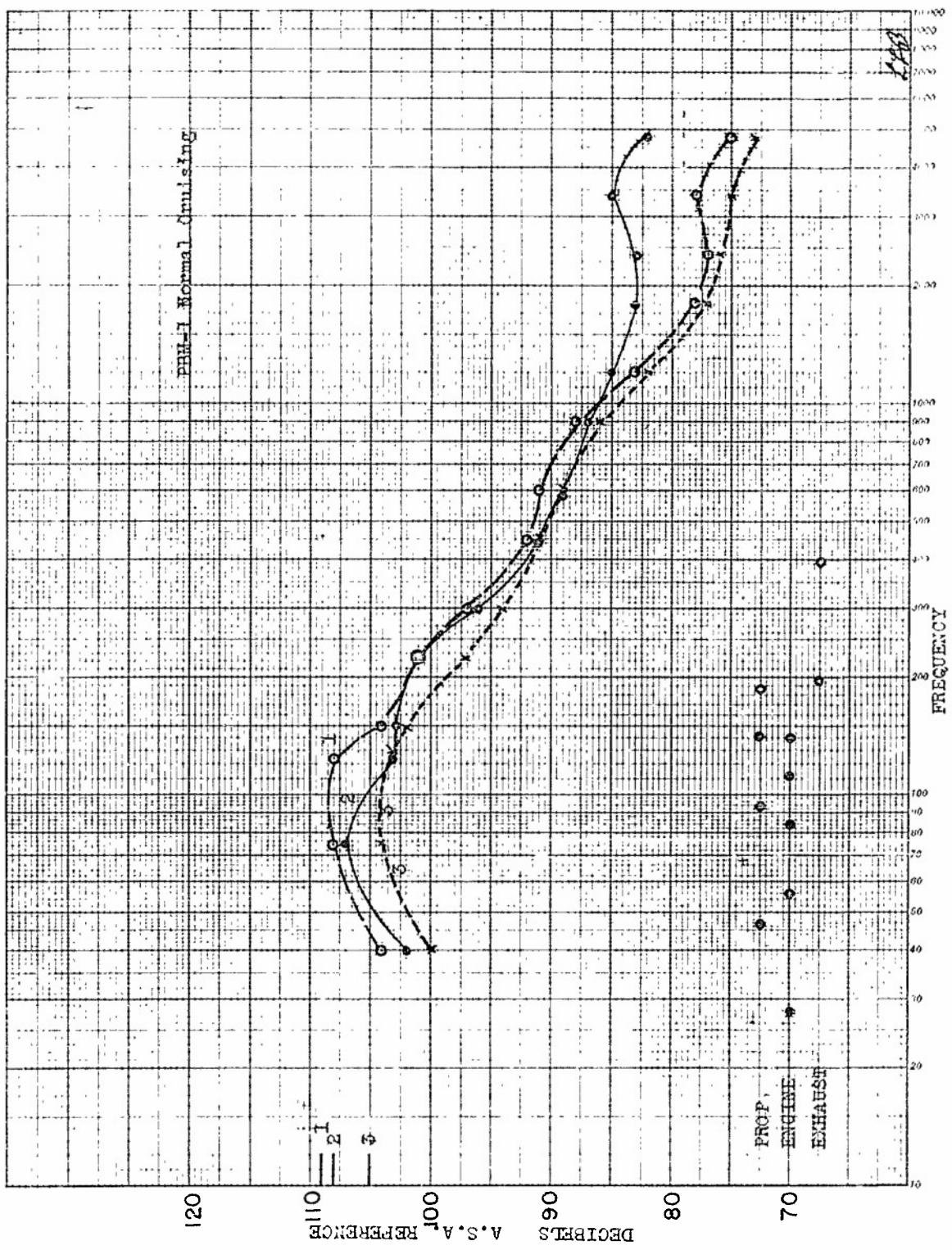

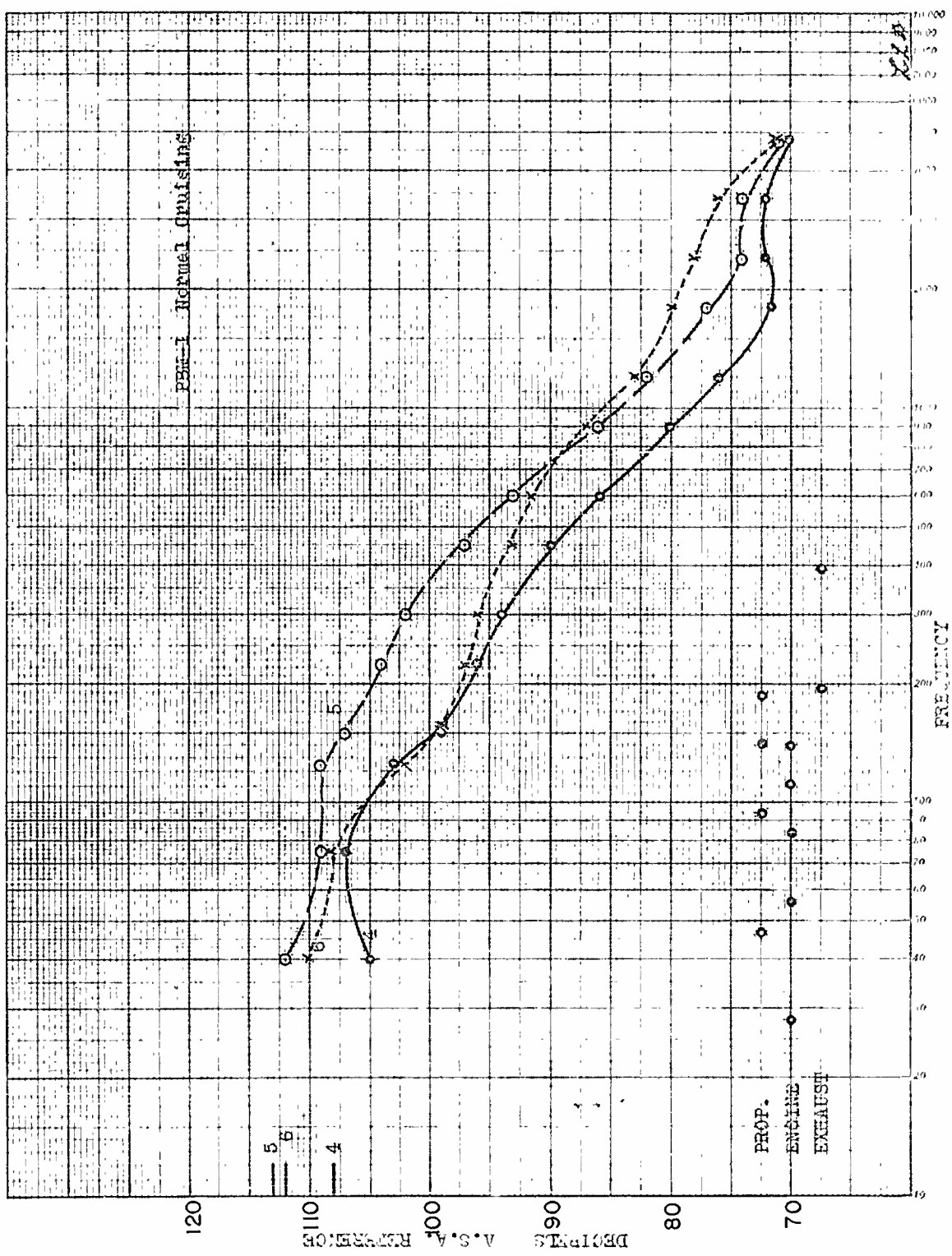

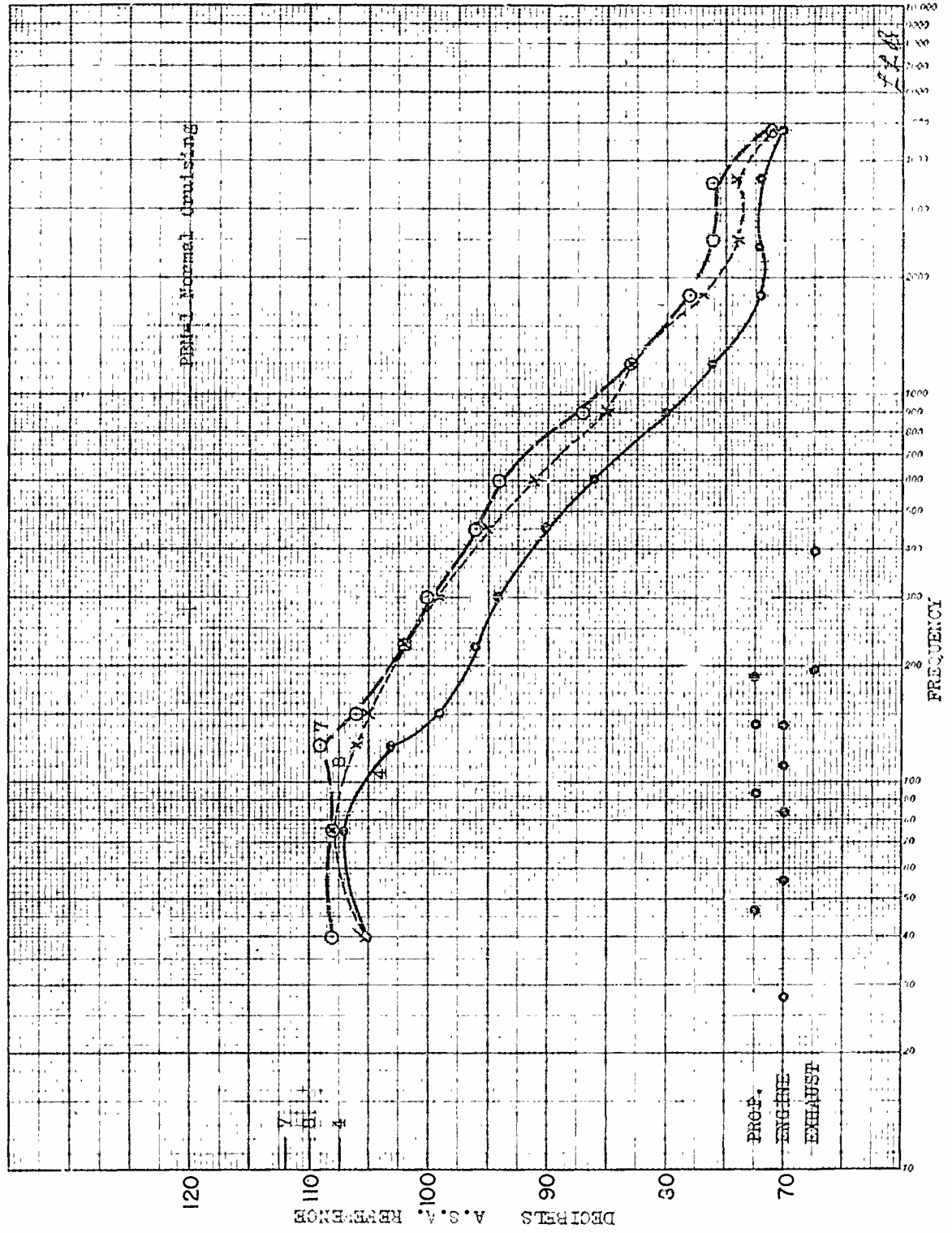

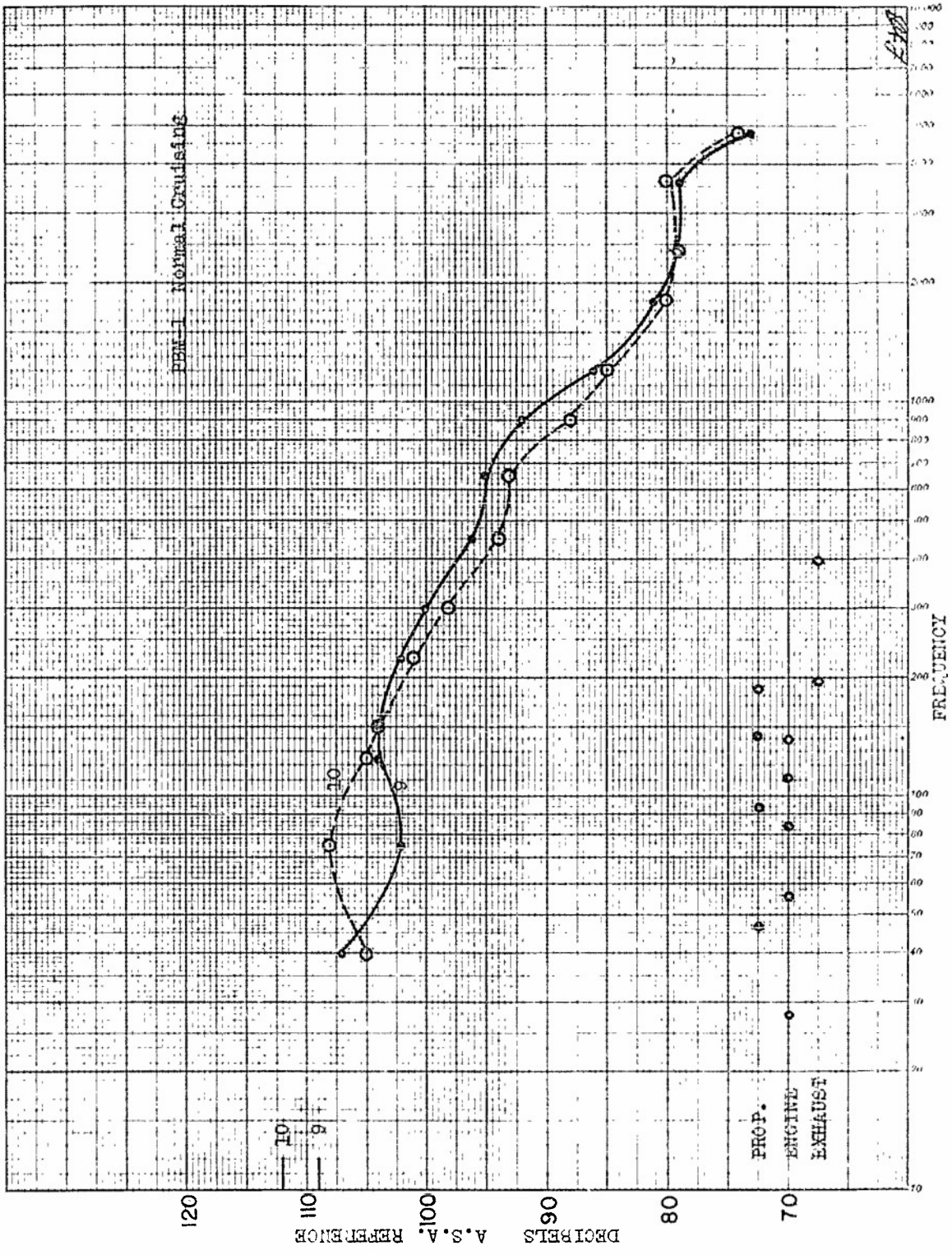

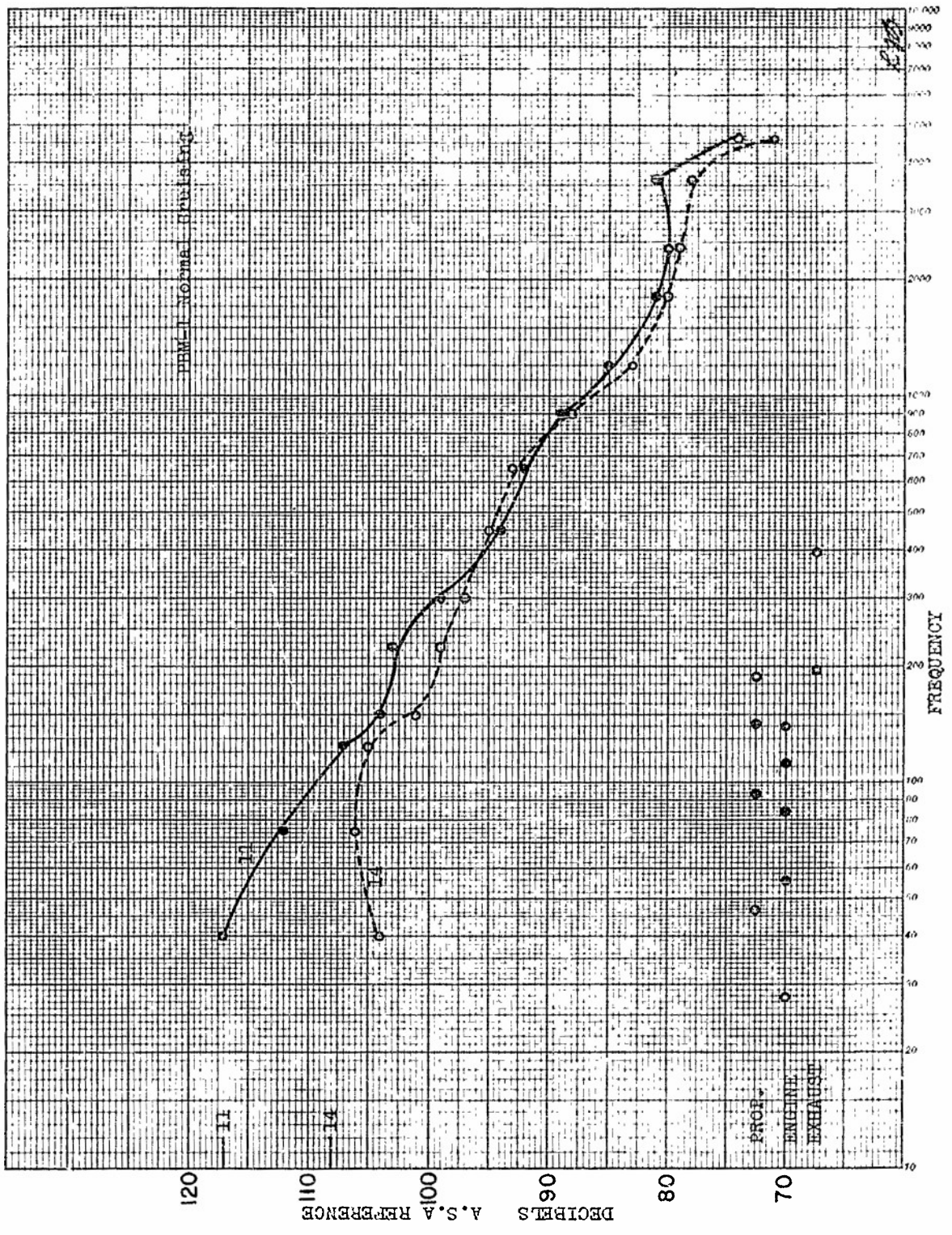

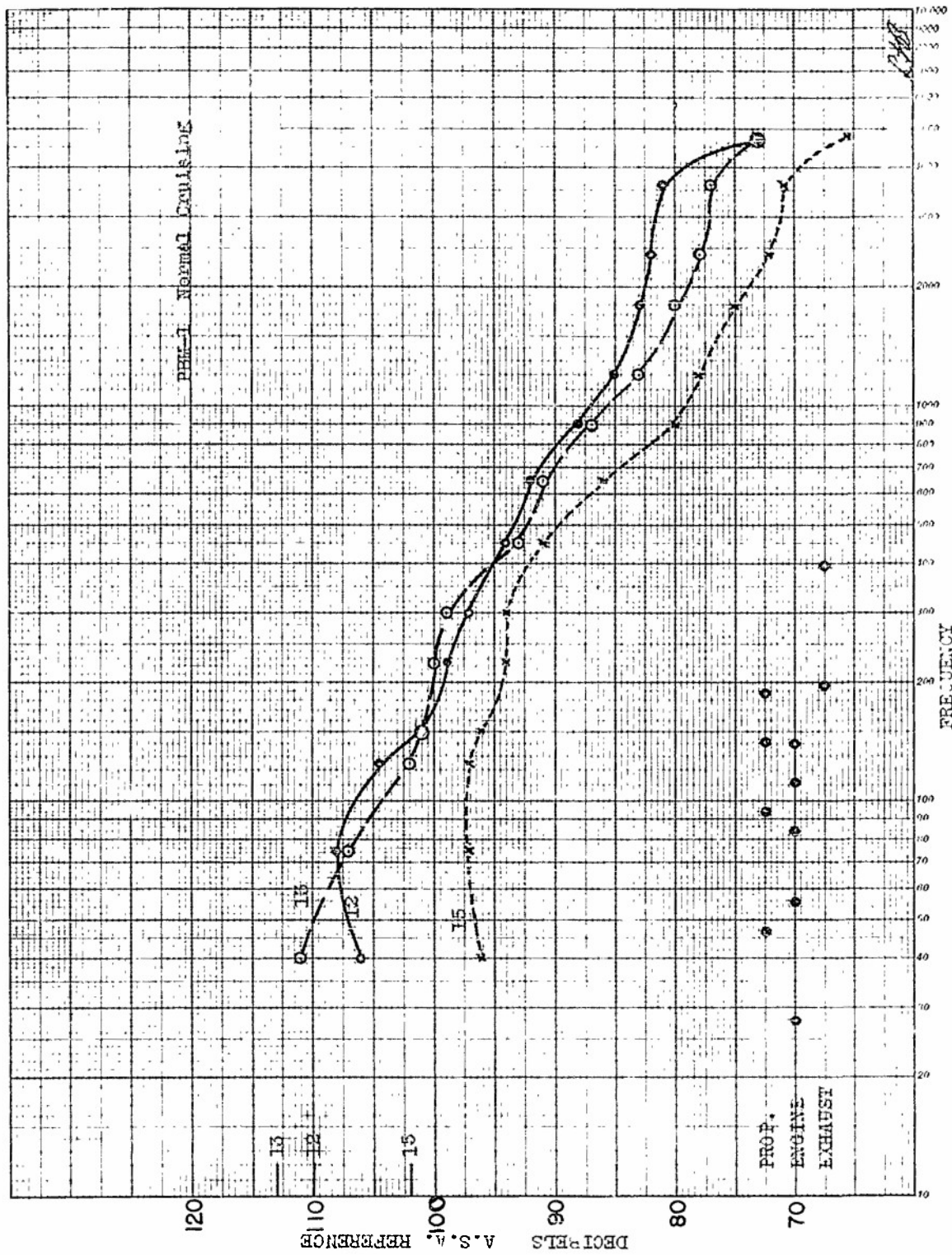

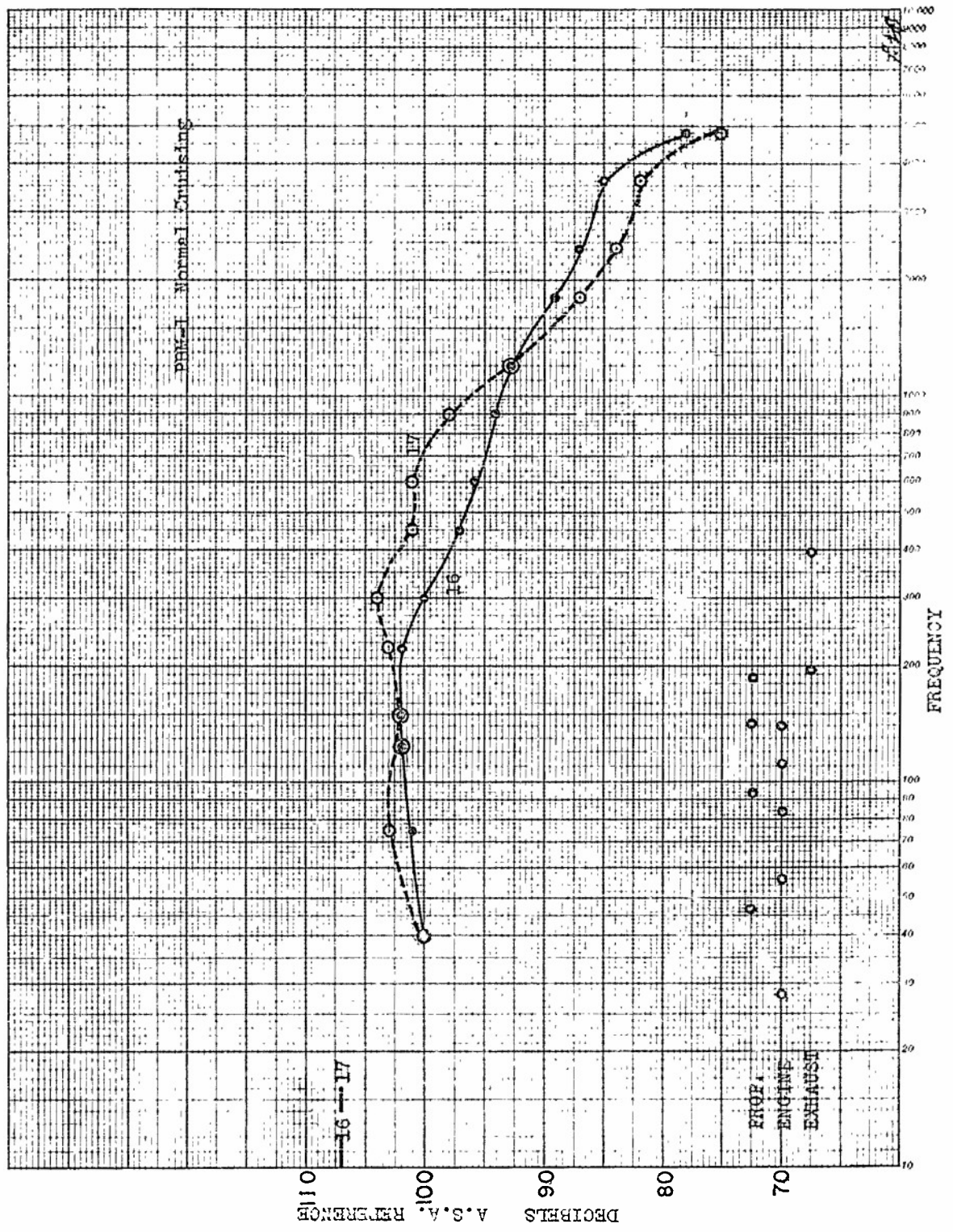

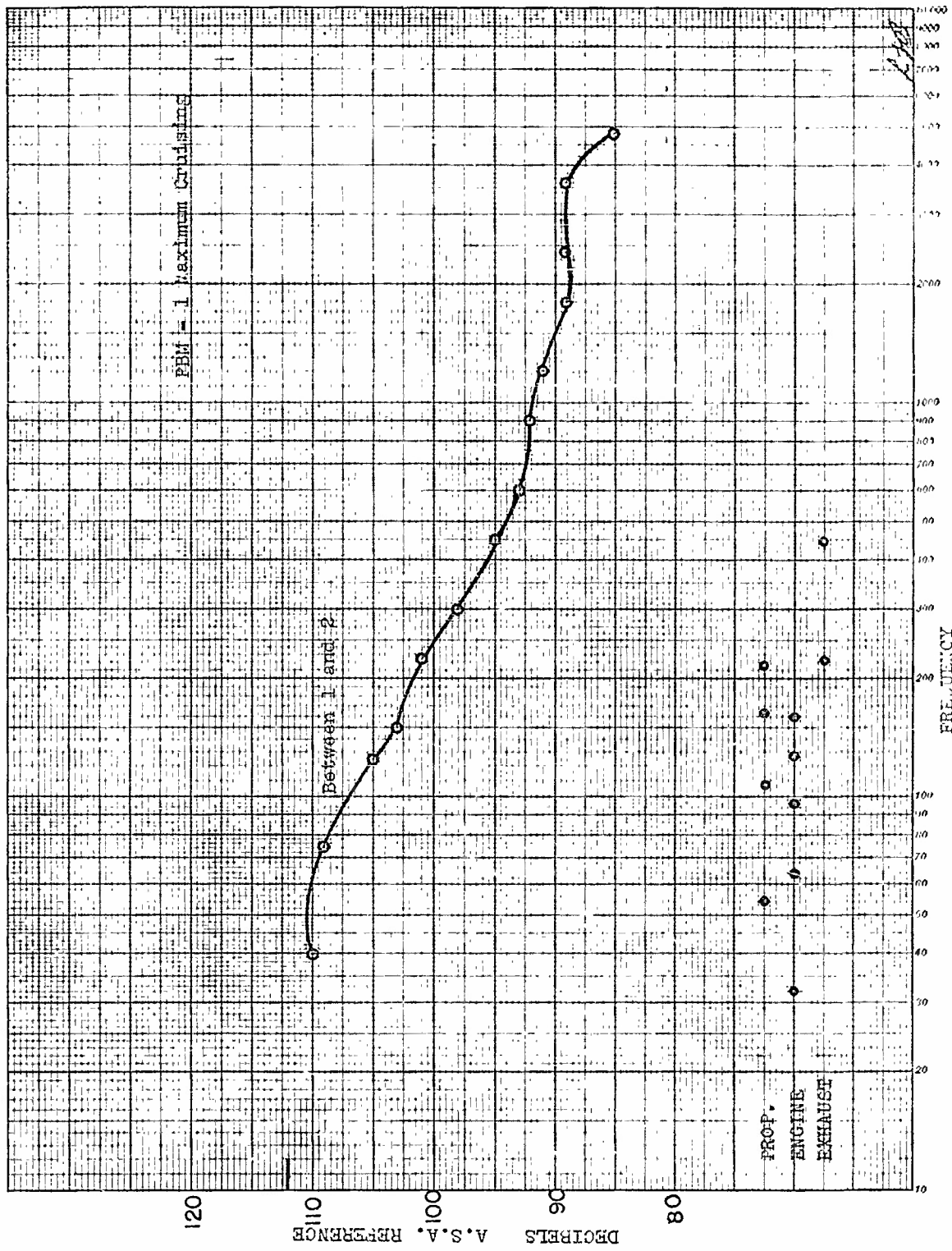

The following flight data apply to the next two pages of graphs.

Type Plane: DC-3B

Engines: Wright G-102

Gear Ratio: 3:2, three blades.

Propeller Diameter: 11.5 ft.

Tip Separation: 7 inches

R. P. M. 1850

True Indicated: Air Speed: 160 mph.

M. P.: 27 in.

H. P. 600 per engine

T° : 32°F

Alt: 8000 ft.

DOUGLAS DC-3B

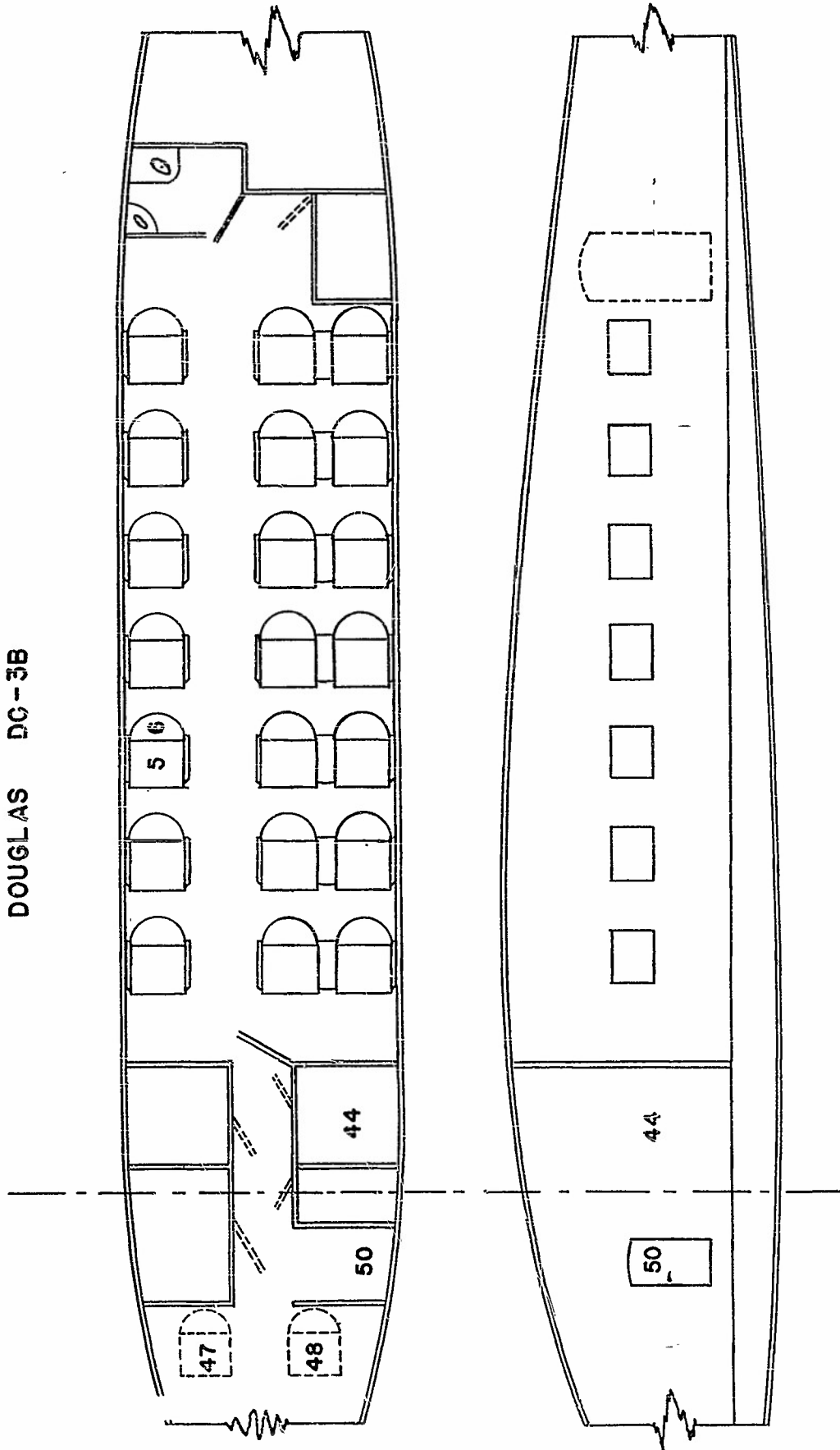

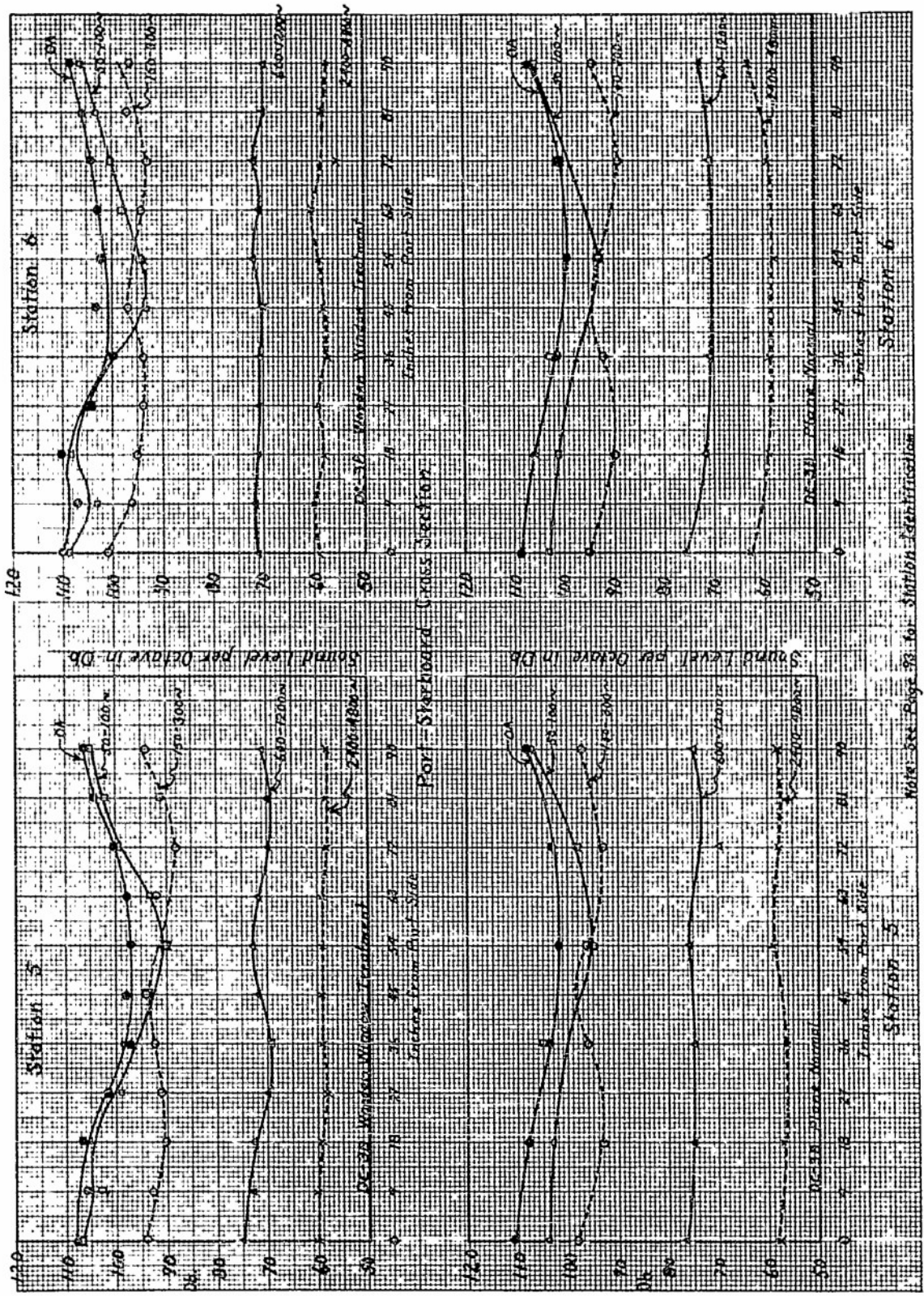

Note: See Page 89 to Station Identification

Douglas DC-3B

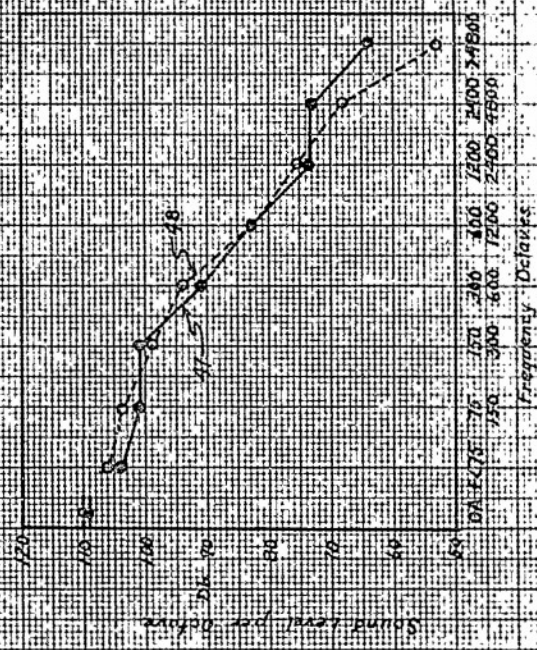
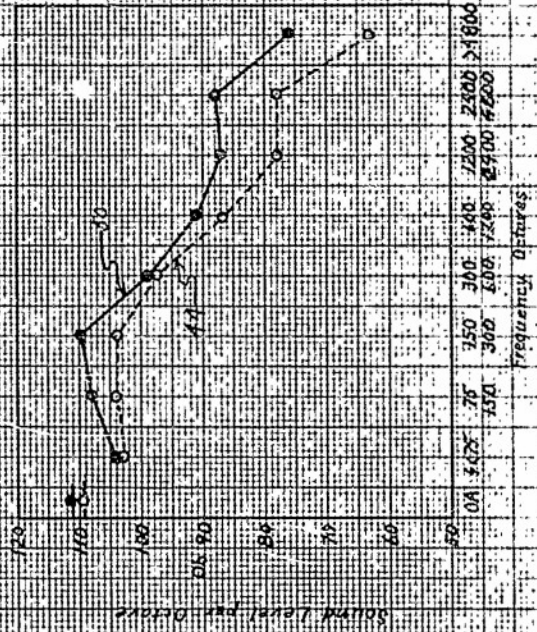

Note: See page 93 for Station Identification

Frequency Octaves

Frequency Octaves

The following flight data apply to the next two pages of graphs.

Type Plane: CW - 20

Gear Ratio: 9:16, three blades.

Propeller Diameter: 14.5 ft.

Tip Separation: 24 inches.

R. P. M. : 1900

True Indicated Air Speed: 180 mph

M. P.: 28 inches

H. P.: 900 per engine

T^o : 40°F

Alt.: 7000 ft.

Plane of Propellers

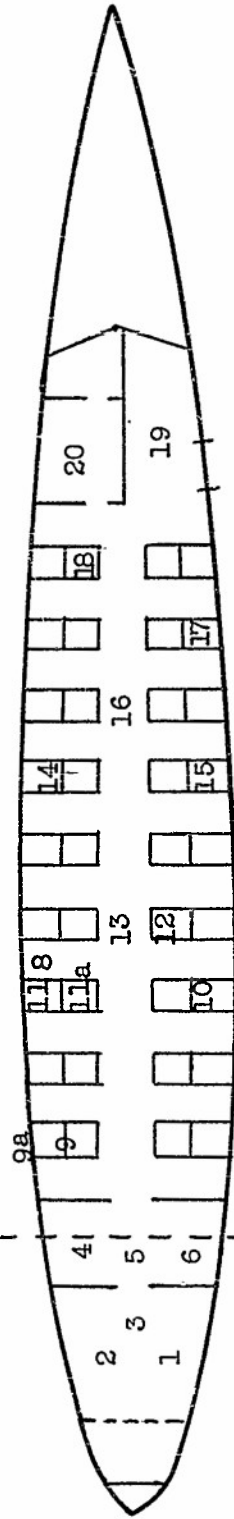

All positions except 7, 13, 16, 19 and 20
Head Height, Sitting.

Positions 13, 16, 19 and 20 Head Height,
Standing.

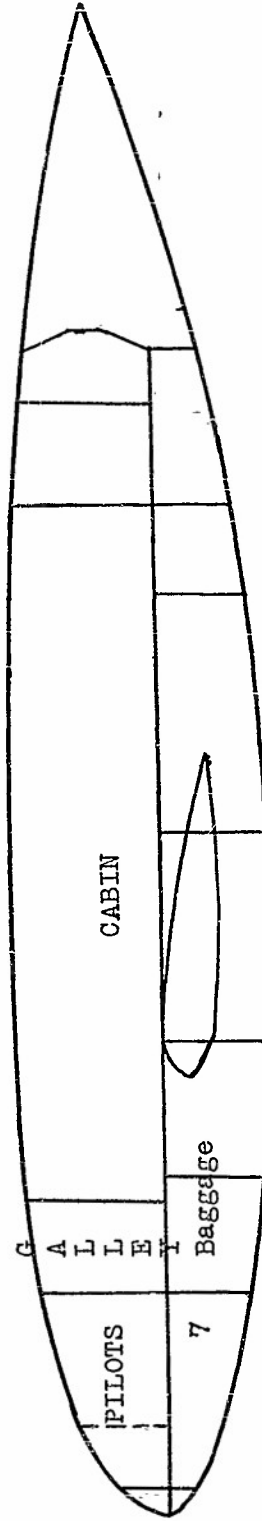

NRC - CRUFT SOUND TESTS MAY 18, 1941

CW - 20A

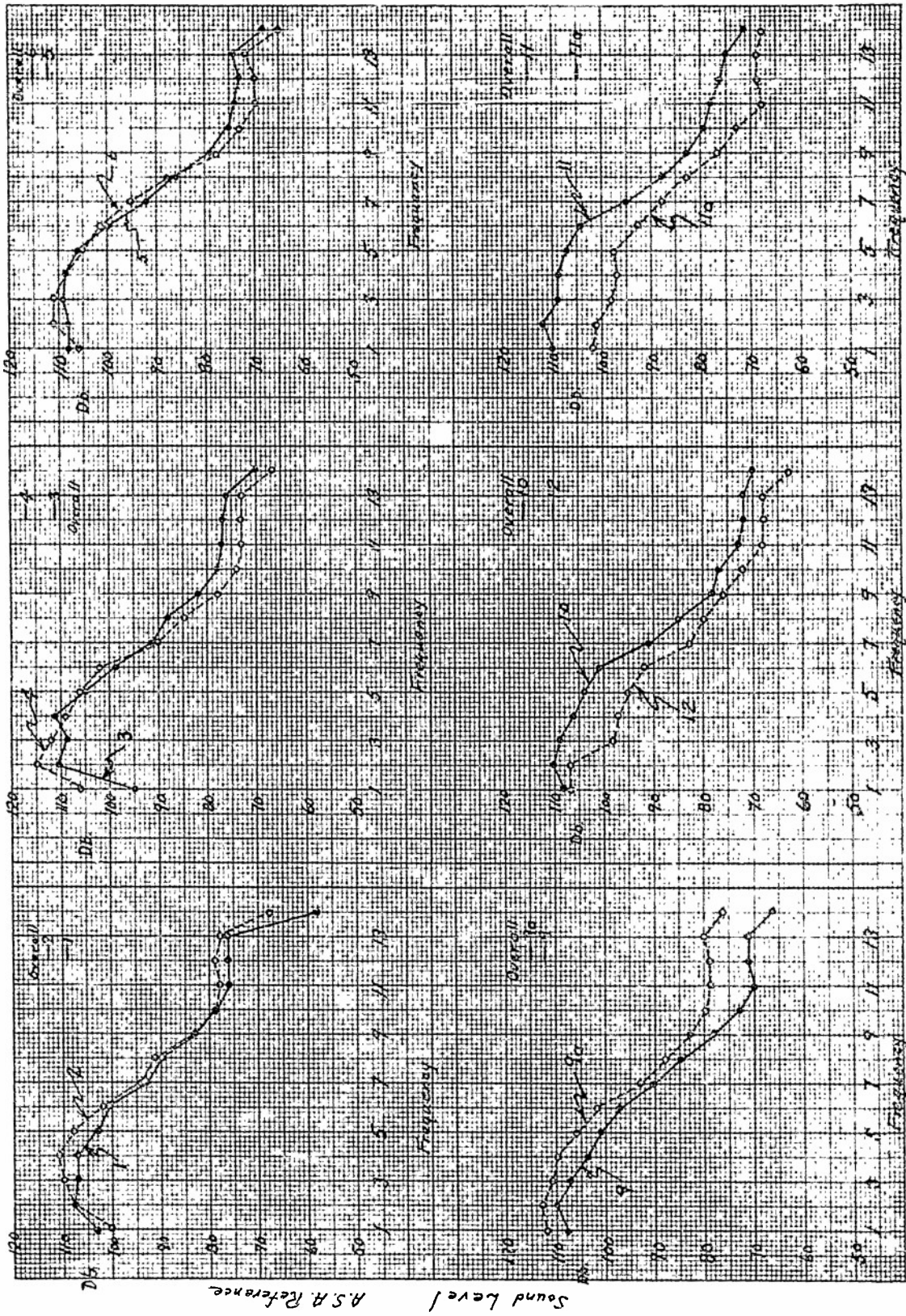

Sound level
A.S.A. Reference

RPM 1920 Ind Air Speed 170 M P H
M P 28" Outside T 40°F
Altitude 7000 ft Propeller Dia 14.5 ft
Propeller Tip Sep 24 in

C.W.-20A.
May 18, 1941

13 = 2400 ~ 4800 ~
14 = above 4800 ~

9 = 600 ~ 1200 ~
10 = 800 ~ 1600 ~
11 = 1200 ~ 2400 ~
12 = 1600 ~ 3200 ~

1 = below 50 ~
2 = 50 ~ 100 ~
3 = 150 ~ 300 ~
4 = 100 ~ 200 ~
5 = 150 ~ 300 ~
6 = 200 ~ 400 ~
7 = 300 ~ 600 ~
8 = 400 ~ 800 ~

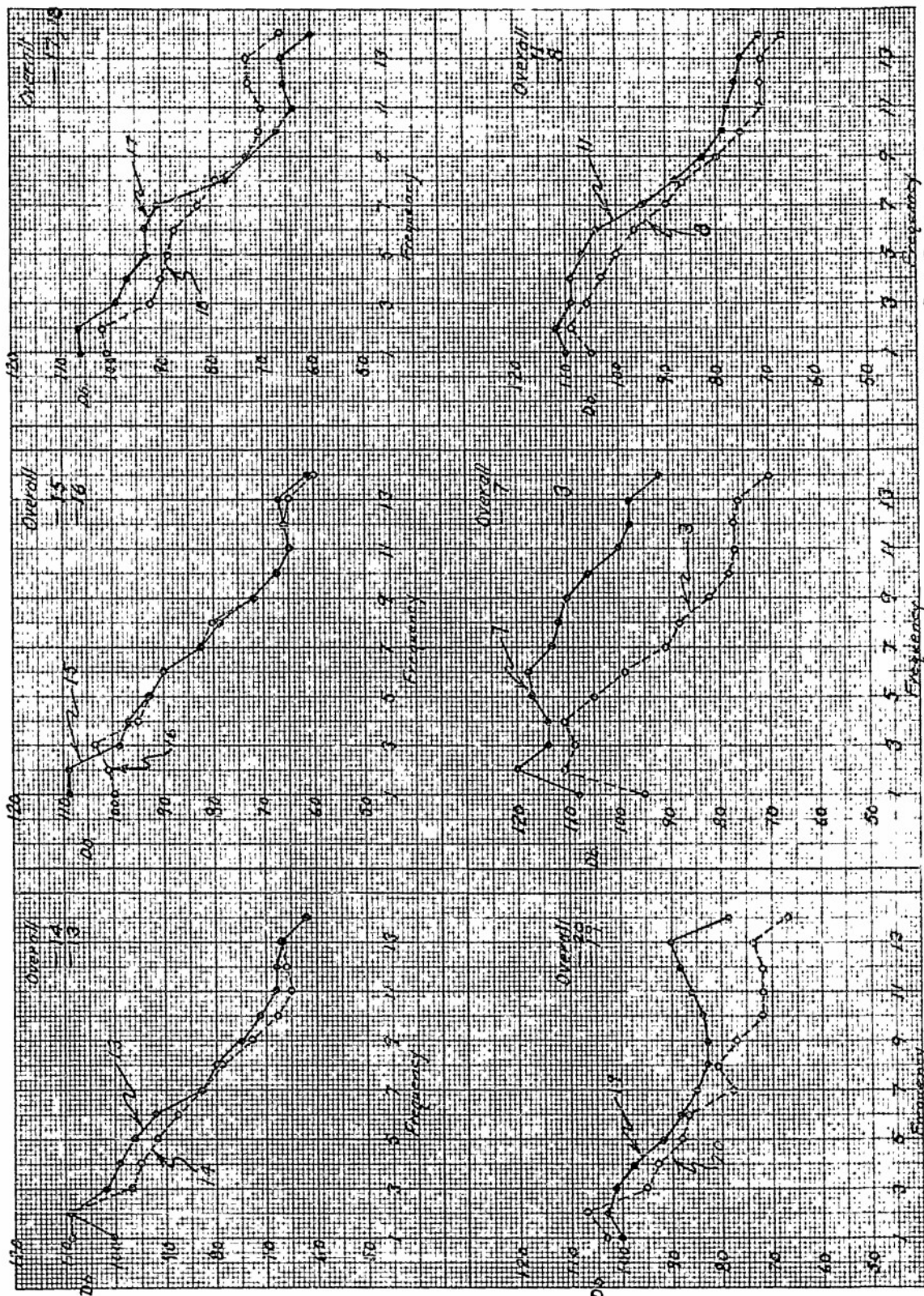

A.S.H. Reference

Sound Level

R.P.M. 1920 Ind Air Speed 170 MPH
 M.P. 28 Outside T 40°F
 Altitude 7000 ft Propeller Dia. 14.5 ft
 Propeller Tip Sep. 2.4 in

CW-20A
 May 18, 1941

13 = 2900 → 4800 ~
 14 = above 4800 ~

9 = 600 → 1200 ~
 10 = 800 → 1600 ~
 11 = 1200 → 2400 ~
 12 = 1600 → 3200 ~

5 = 150 → 300 ~
 6 = 200 → 400 ~
 7 = 300 → 600 ~
 8 = 400 → 800 ~

1 = below 50 ~
 2 = 50 → 100 ~
 3 = 75 → 150 ~
 4 = 100 → 200 ~

ACOUSTICAL PROPERTIES OF MATERIALS

a. Introduction.

The most familiar measure of the sound absorbing properties of an acoustical material is its "absorption coefficient", defined as the ratio of energy absorbed to that incident upon the sample when the incident energy is at random angle. More recent studies have indicated that such a simple concept is meaningful only in certain idealized cases, and that it is entirely unjustified and often seriously misleading to consider a measured absorption coefficient as characteristic of the general acoustical behavior of a material. An absorption coefficient has no meaning whatever unless the experimental conditions of mounting of the material, its spacing out from a rigid wall surface, etc. are stated. Furthermore, such a measured coefficient is applicable for the material only for very similar mounting conditions. The ability to absorb sound must be thought of as characteristic of the entire structure, material, method of mounting, spacing, backing wall, etc., rather than of the material alone. Changing the spacing out from the backing wall from zero to an optimum value may alone change the measured coefficient by a factor of 5 to 20 or more. These recent studies indicate that a more general property in determining the acoustical behavior of a material is its acoustic impedance, that is, the complex ratio between the pressure and the normal component of particle velocity at the surface. Because of its greater generality and usefulness, the concept of acoustic impedance has been adopted for the present study of sound absorbing materials. The "absorption coefficient" is still a useful concept, particularly for approximate calculations, but we must realize its limitations, and the fact that there are for any given material many such coefficients.

The acoustic impedance is a two parameter function (real plus imaginary parts or magnitude plus phase, etc.) which tells not only how it did behave, but also how the material can be expected to behave under other than the measured conditions. Furthermore, with a bit of theoretical background, it enables us to predict how the material or its mounting, or both, should be modified in order to change the resultant acoustical properties. In particular, a brief study of acoustic impedance enables us to specify the definite limitations due to weight, thickness, flow resistance, spacing, etc., for any not too complicated absorbing material or structure.

In order not to lose sight of the relation between the familiar concept of absorption coefficient and acoustic impedance, it will be worthwhile to consider the four most useful coefficients in terms of impedance. Rather than working with the impedance itself, it will be more convenient to divide the impedance by the characteristic impedance of air, $\rho c = 42$ c.g.s. units. In usual notation

$$Z/\rho c = \frac{R}{\rho c} + j \frac{X}{\rho c}$$

where

$Z/\rho c$ = acoustical impedance in ρc units

$\frac{R}{\rho c}$ = acoustical resistance

$\frac{X}{\rho c}$ = acoustical reactance

ρ = density of air

c = velocity of sound in air

Now we have the following coefficients:

- 1) Free wave, any angle of incidence;
- 2) Standing wave-normal incidence;
- 3) Standing waves - truly diffuse sound;
- 4) Experimentally measured.

1) When a plane sound wave strikes a surface of impedance Z with an angle of incidence, the fraction of the sound absorbed is given as a function of φ by the equation

$$\alpha(\varphi) = 1 - \left| \frac{Z/\rho c \cos \varphi - 1}{Z/\rho c \cos \varphi + 1} \right|^2$$

Contours of $\alpha = \text{constant}$ as a function of $R/\rho c$ and $X/\rho c$ for normal incidence, i.e. for $\varphi = 0$ or $\cos \varphi = 1$ are plotted on page 109. They hold for any other angle of incidence if Z is multiplied by $\cos \varphi$. This coefficient for normally incident free waves will be called α_{nf} .

2) Theory has shown that in nearly all cases the initial rate of decay of sound in a room, when expressed as a reverberation time, is determined by the decay rate of sound normally incident on the absorbing surfaces. The corresponding coefficient for the Sabine reverberation formula is called the normal coefficient, α_n , and is given approximately by the equation

$$\alpha_n = \frac{8 R/\rho c}{(R/\rho c)^2 + (X/\rho c)^2}$$

Contours of constant α_n are plotted on page 111, as functions of $R/\rho c$ and $X/\rho c$. It will be noted that α_n has values greater

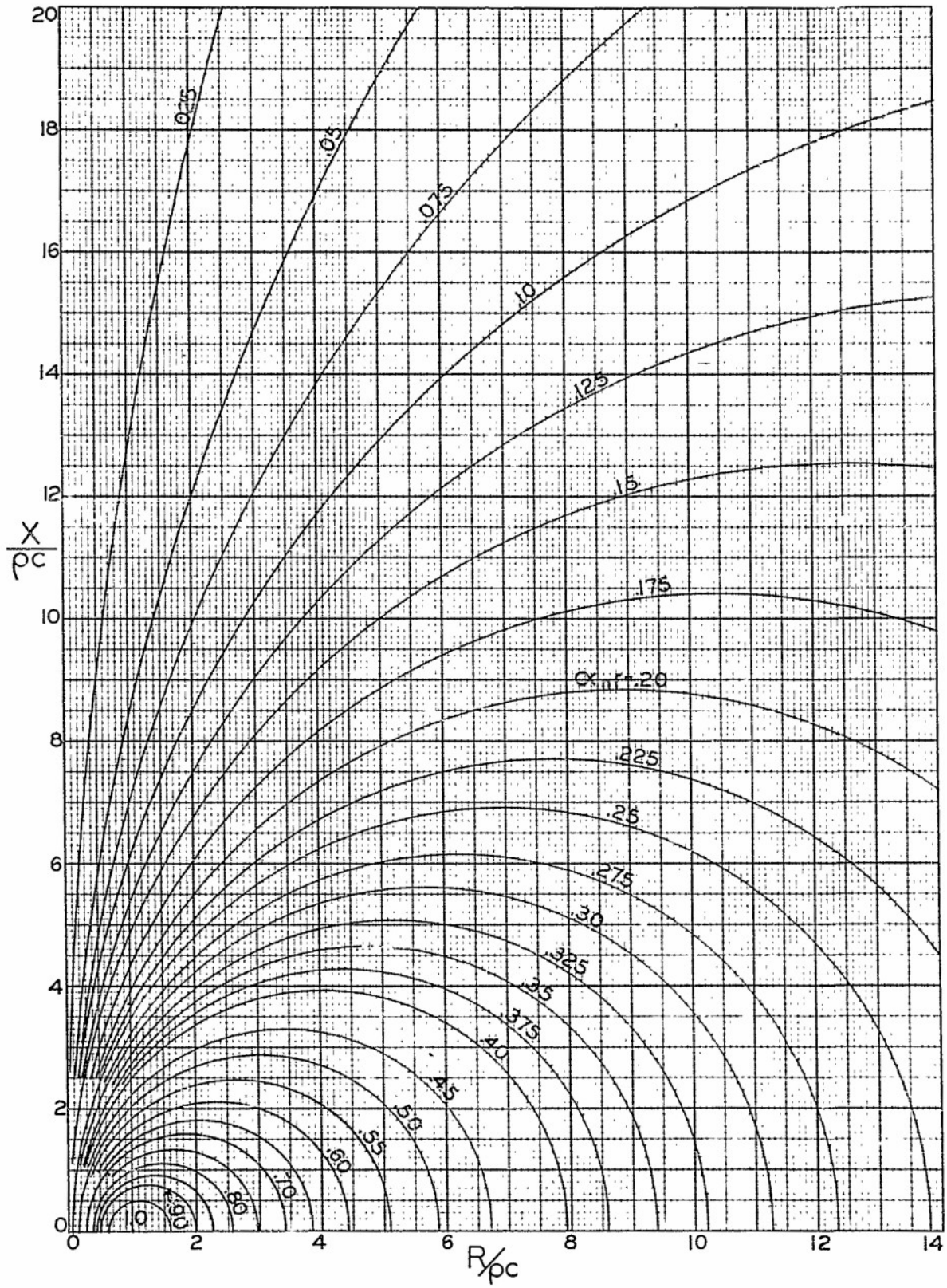

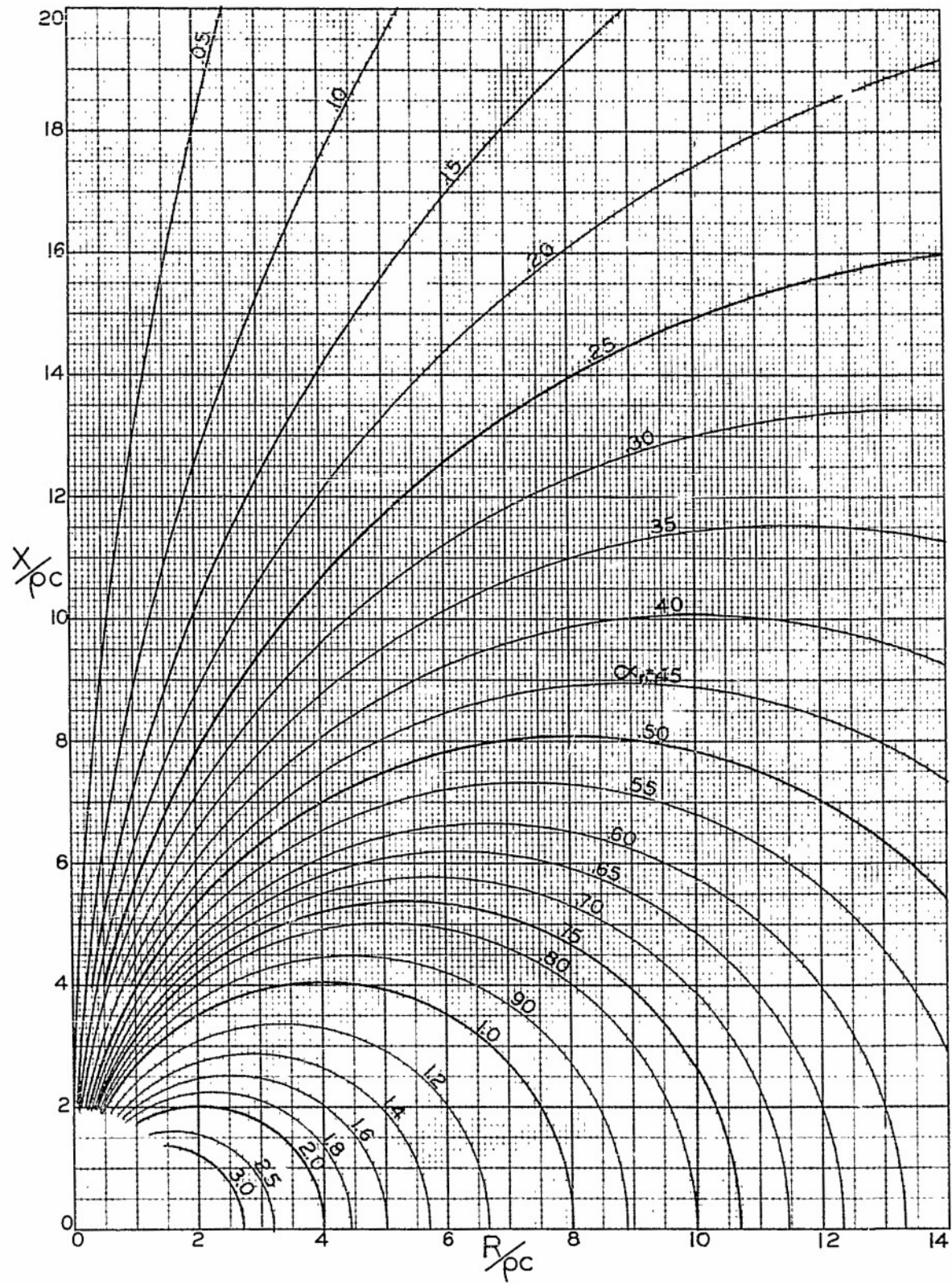

than unity, and therefore cannot be a true absorption coefficient.

3) The Sabine, or statistical absorption coefficient, is the coefficient which would be measured by the Sabine method in an ideal reverberation chamber with truly diffuse sound. It is given by a rather complicated equation. Contours of constant $\bar{\alpha}$ plotted as functions of $(R/\rho c)$ and $(X/\rho c)$ are almost circular, and are plotted as circles on page 115. To within $\pm .01$, these coefficients are the same as are given by $\alpha(\varphi)$, if an average value of $\cos \varphi$ is taken as from .55 to .70, depending upon the magnitude of Z .

4) The values of absorption coefficient measured under standardized laboratory conditions and reported by the Acoustical Materials Association will be referred to as $\alpha_{A.M.A.}$. They are chamber coefficients, characteristic of the particular rooms, sources, etc. used in their measurement. The A. M. A. coefficients as published usually approximate the corresponding α_n for frequencies below 500 c.p.s., and usually approximate the corresponding $\bar{\alpha}$ at frequencies above 2000 c.p.s. In the middle range they usually fall in between the corresponding α_n and $\bar{\alpha}$. This shift from α_n to $\bar{\alpha}$ is to be expected from theoretical analyses. It is, therefore, a simple matter to go from the acoustic impedance of a material to a reasonable estimate of what its experimental absorption coefficients may be expected to be. The discrepancies between such predicted values and measured values are, ordinarily, no greater than discrepancies between values obtained experimentally by various laboratories.

b. Equivalent Electrical Circuits and Design Objectives.

Acoustic impedance is a convenient concept because of the analogies between it and electrical impedance. As soon as we identify the acoustic analogies to electrical resistances, condensers and inductances, we can apply familiar circuit theory; and, in many cases when the acoustic structures have distributed constants, or when they are not small compared with a wavelength of sound, we can apply familiar electrical transmission line theory. With the aid of these concepts and using the mathematical techniques already worked out for handling impedance functions, we can more easily bridge the gap between the physical characteristics of a material which determine its behavior and the final sound absorbing properties of the material plus its mounting.

It is well known that to get the most electrical energy from a transmission line into a terminating network, the network impedance must be properly matched to the line impedance. The analogous line or characteristic impedance of air is equal to its density times its velocity, that is, ρc , and is 42 c.g.s. units. For a wall to absorb as much incident sound as possible, pages 109 and 115 show that its acoustic impedance Z should be

properly matched to air, that is, $Z/\rho c = 1$ for normal incidence and $Z/\rho c = 1.5$ for random incidence. The following discussion will hold strictly only for sound at normal or near-normal incidence, but nevertheless probably applies to the majority of the objectionable sound in airplane cabins. To include variation of impedance with angle of incidence would complicate the analysis more than the increase in accuracy would warrant at present.

The design objective for a good absorbing wall, then, is that the ratio $Z/\rho c$ be near to unity. If we can represent the elements of the wall structure as parts of an equivalent electrical network, we can from this network calculate the optimum choice of material, spacing, etc., compatible with any necessary restrictions of weight, cost, etc. The equivalent network will, furthermore, enable us to calculate the transmission of sound through the wall, as well as absorption of sound by it.

Analogous to electrical resistance is acoustical flow resistance, defined as the ratio of pressure drop across a porous material to the velocity of flow through it. This resistance can be measured by an apparatus described later. In a sound absorbing structure a spacing cavity or volume of air of d cm. acts, for low frequencies, as an equivalent electrical condenser of capacity $d/\rho c^2$. For higher frequencies the reactance $X/\rho c$, of such a cavity is given by

$$X/\rho c = -\cot \frac{2\pi d}{\lambda} \quad \text{Eq. (3)}$$

A mass of air or other material of surface density m_1 grams per cm^2 which is "pumped" (i.e., moved) back and forth by a sound wave acts as an inductance of reactance

$$X/\rho c = \frac{+i\omega m_1}{\rho c} \quad \text{Eq. (4)}$$

Page 117 the acoustic reactance of a cavity of depth 3", 6", or 30" as a function of frequency, and page 119 the reactance of various m_1 's as a function of frequency.

Cross sections through three possible type of fuselage structure, together with their equivalent electrical circuits, are indicated on page 121 (a), (b) and (c). Following filter theory convention, each section of the structures is represented as a two-terminal pair. Thus a simple wall structure has only one or two sections, a multiple layer structure has several more or less similar sections all to be connected in series. When the sections are connected in series the impedance, $Z/\rho c$, which the room "looks into" to the right determines the normal incidence absorption coefficient.

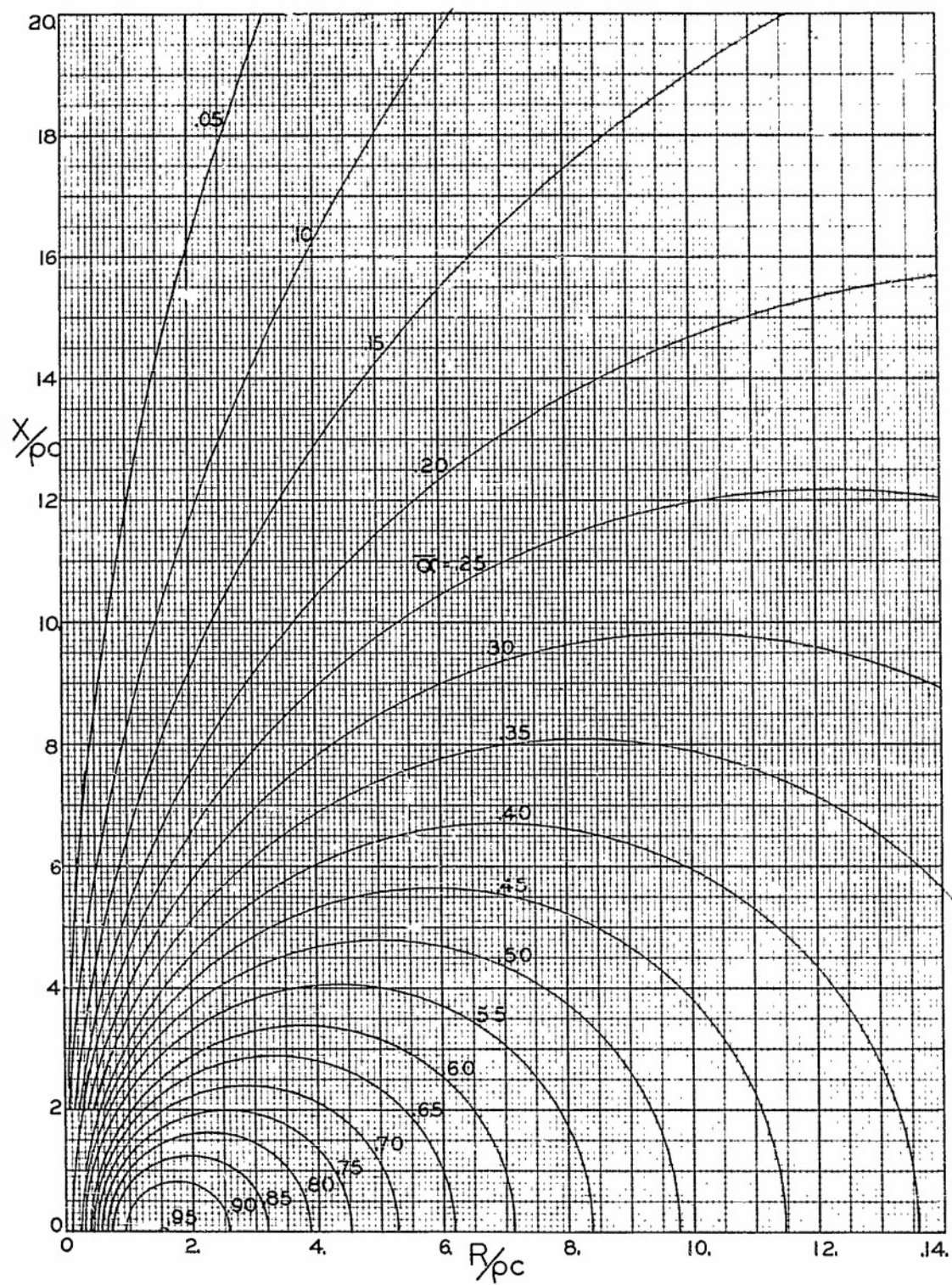

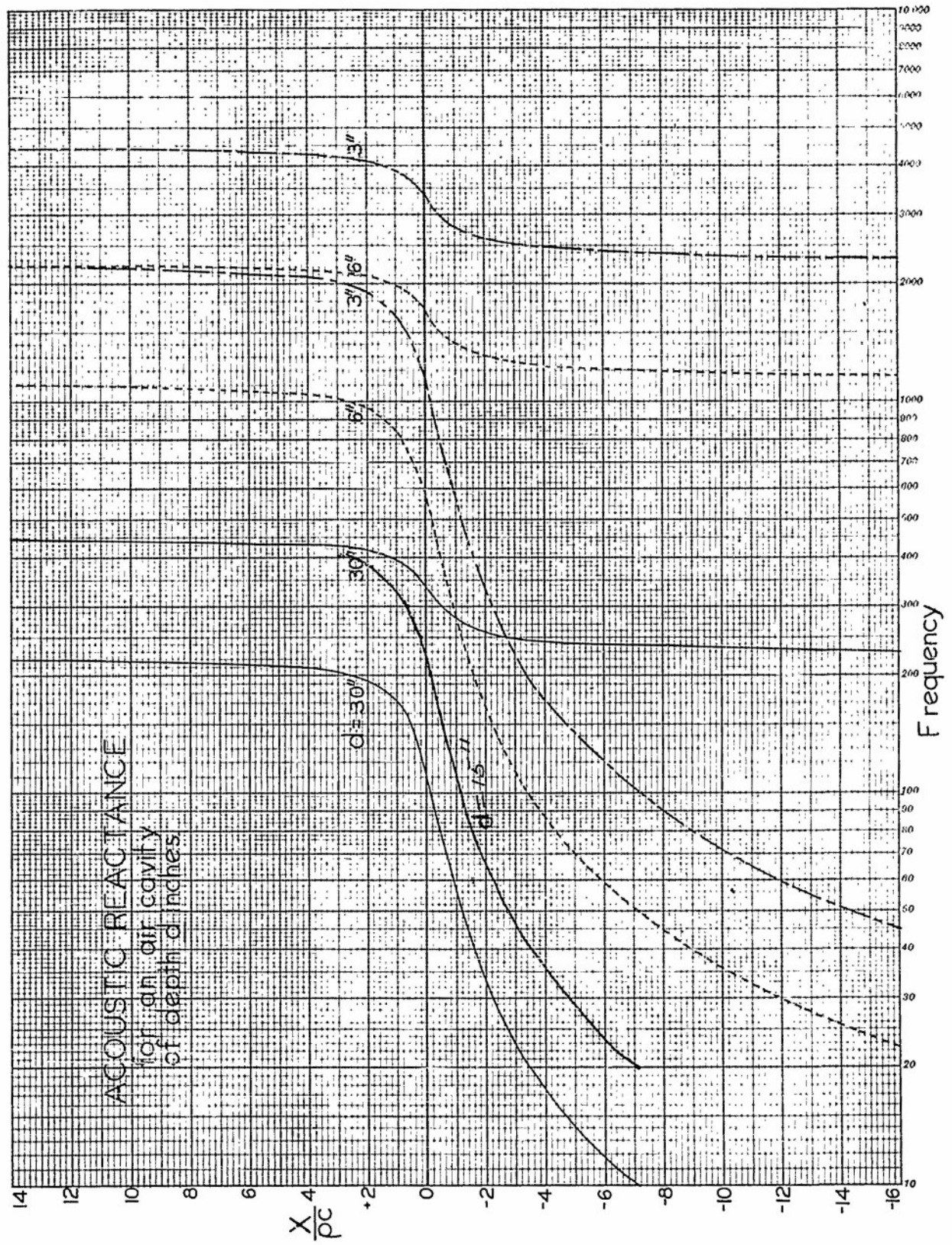

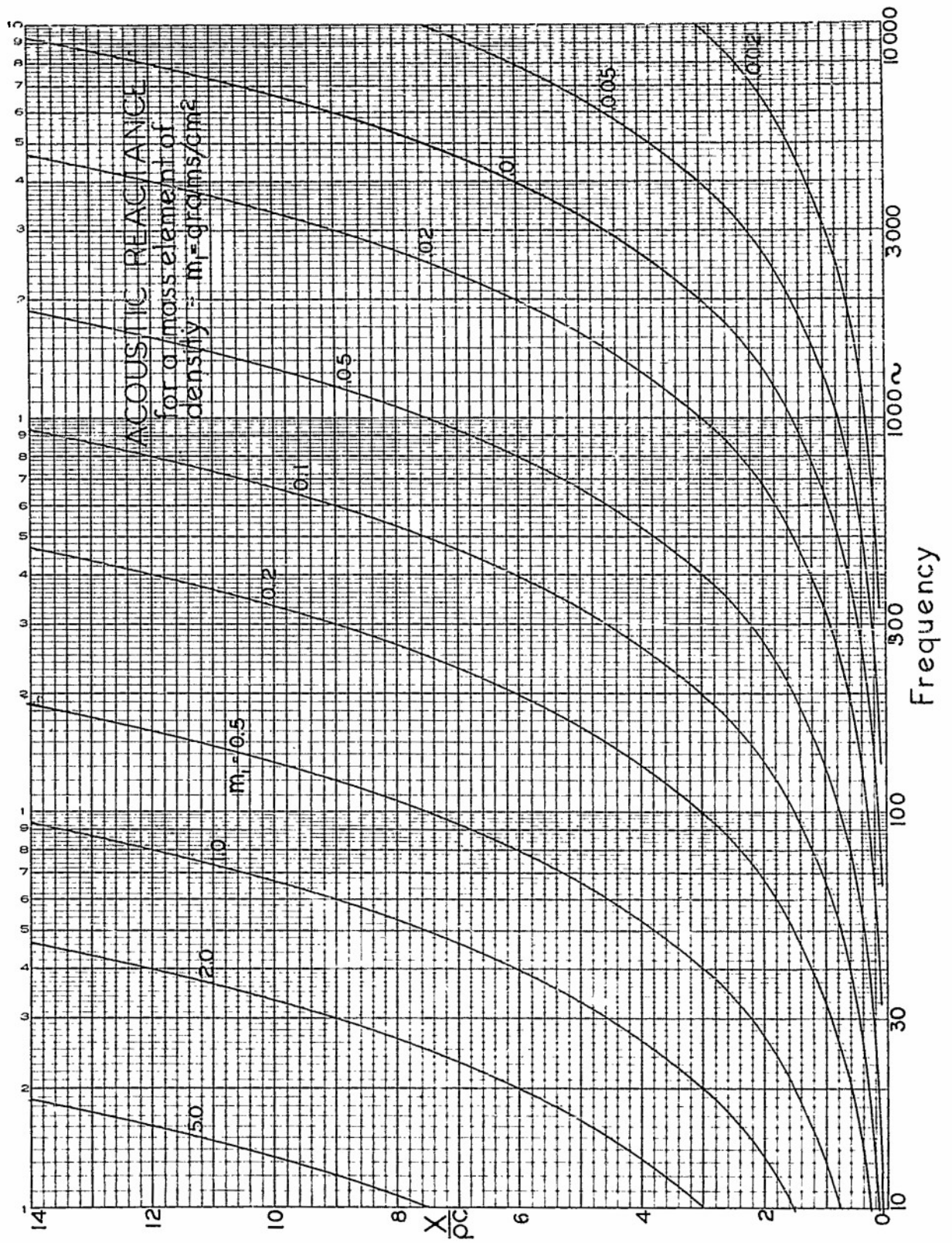

(a)

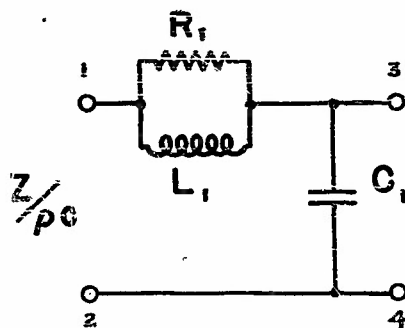

(b)

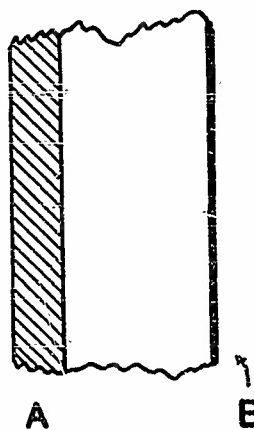
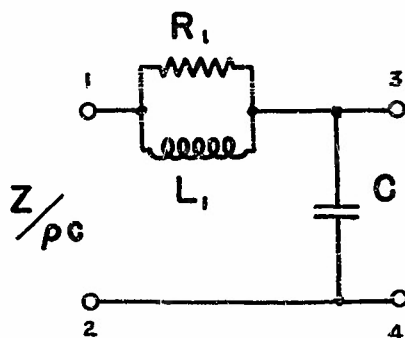

(c)

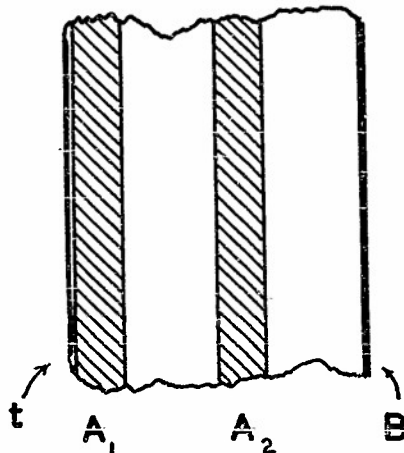
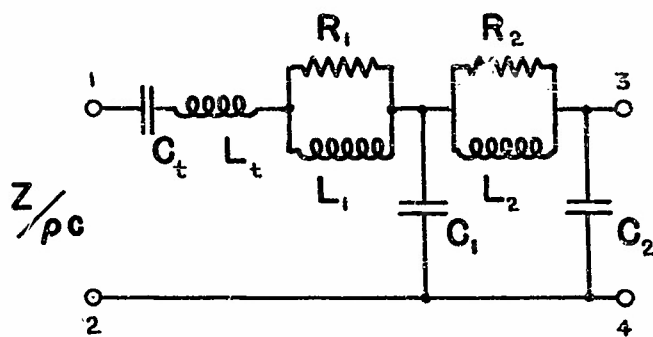

EQUIVALENT CIRCUITS

The circuits on page 121 are much simplified. Actually the dural skin B has a number of resonant frequencies, and should be represented as a number of parallel series resonant circuits connected across terminals 3 - 4. This part of the circuit probably represents a fairly high impedance and does not markedly affect the absorption characteristics of the structure. It will be considered in detail in the section on transmission.

The acoustic impedance of a porous layer of thickness l cm. against a rigid backing, is given as $Z/\rho c$ in (a) on page 121. It is approximately the impedance of a resistance and condenser in series. This network has been derived theoretically and corroborated experimentally on small samples. This resistance is approximately one third of the flow resistance, $r l / \rho c$, (r = specific flow resistance) and the capacity is given by $P l / \rho c^2$ where P is the porosity of the material. The porosity is the ratio of the volume of the voids in the material to the total volume of the material, and is very close to unity for most light and porous materials as used in airplane acoustic treatments.

The equivalent network of a single layer of porous material spaced out a distance d from its backing is given in (b). Here the resistance R_1 is approximately the measured D. C. flow resistance, the condenser C_1 represents the spacing cavity, and the inductance L_1 the surface density of the material. The reason for this shunt inductance across the resistance is clear if one keeps in mind the analogy between electrical current and acoustical particle velocity. Air can be forced into the cavity condenser either by being forced through the material (resistance branch) or by moving the material itself (inductance branch). At low enough frequencies sound pressure on the inside face of the treated cabin moves the absorbing material rather than pumping air through it, and as a result the energy dissipation and sound absorption are both small.

These two equivalent networks are typical; more complicated absorbing structures can easily be built up. In general, the most complicated structure is represented by ladder-type sections connected in series. There is a shunt capacity for each air space, and a series inductance for each massive layer, with a series condenser if the massive layer has stiffness. An impervious layer has no flow resistance element across it, but if it has internal damping there must be a resistance in series with it. Thus, the simplest representation of the dural skin and braces is a simple series circuit of resistance, inductance and capacity. As an example (c) on page 121 represents two layers of spaced porous material with a third non-porous layer facing off the structure. For exact representation over a wider frequency range additional elements must be included, but the approximate networks given here are adequate for the present problem.

The acoustic behavior of most common airplane materials can be reasonably accurately predicted from the simple measurements of flow resistance and surface density. From a design viewpoint the initial limiting factors are usually the maximum allowed cavity depth, maximum allowed weight of sound absorbing material and simplicity of removing the absorbing treatment. Consideration of the equivalent circuit (a) on page 121 and absorption coefficient curves on page 109 show that a single layer of material directly against the fuselage skin can have very little absorbing power at low frequencies, because the reactive component of the impedance is much too large. The only effect, and it may be significant, of such a layer, is to cut down on transmission through the panel by helping to damp out panel resonances.

For the next most simple structure, a spaced material, the maximum absorption is limited by the cavity reactance at low frequencies. It is clear from the contours on page 109 that for a given reactance ($Z/\rho c > 1$), the optimum absorption is obtained when the resistance and reactance are approximately equal. To choose a material for maximum absorption at given frequency, we must calculate the optimum flow resistance ($rL = R$) for the given reactances of C and L (allowed mass/area) to give the optimum absorption.

The equivalent network for a spaced layer of absorbing material will be recognized as a section of low-pass filter. Sound of low enough frequency will pass through the "absorbing" section without absorption, and then will either pass out through the fuselage shell, or will be reflected unimpeded right back into the room. Since the shell is usually a high impedance, reflection usually occurs and the wall structure is thus seen to be a very poor absorber at low frequencies. One design then is to push this effective filter cut-off down low enough to include the predominant frequencies in the objectionable sound. Furthermore, since the shell is a fairly good reflector, the absorption must be obtained by energy dissipation in the absorbing layer. Two or more sections are, ideally, desirable, but usually involve both too much weight and too much space. If a wide band of frequencies is to be absorbed, several sections are necessary. The first layer should be spaced out from the skin (or an ideal rigid backing plate) far enough to be "tuned" to the highest frequencies to be absorbed. The next layer should be spaced out far enough in front of the first to be tuned to the next band of frequencies, and so on. While an exact analysis becomes difficult, very efficient wide range sound absorbing structures are obtainable where sufficient space is available and weight is not a limiting factor.

A study of sound absorbing structures may be made from two points of view. It may lead to an understanding of the limitations and defects of present designs, or, secondly, it

may lead to new and more efficient acoustical treatments. We shall consider both aspects, limiting ourselves at first to the absorption of sound already inside the cabin, and later treating transmission of external sound into the cabin. Finally, suggestions will be given as to the proper weighting to be given to these two factors in estimating the overall behavior of the complete structure.

Of the possibilities investigated thus far, the structure best suited for the acoustical treatment of airplanes appears to be one or more layers of porous material spaced out as far as practicable from the fuselage skin such as shown in (b) and (c) on page 121. Each layer may be complex, however. A layer of glass or kapok wool, covered with a porous trim material, for example, would constitute a single layer with flow resistance equal to the sum of the flow resistances of the two components and surface density equal to the sum of the densities of the wool and cloth.

In the design of a simple spaced absorber, there are four acoustical variables to be considered; spacing cavity, flow resistance and surface density of the material, and the frequency characteristics of the objectionable sound, as well as moisture and fire resistant properties, cost, durability, etc.

Measurements indicate that the most objectionable frequency components in airplane noise are usually around 90 - 130 cycles. To be specific, let us assume that the optimum absorption is to be obtained for a frequency of 110 cycles. The overall design of the plane, let us say, limits the cavity spacing to 3 inches. Eq. (3) and page 117 show the impedance of the cavity at this frequency is (in $X/\rho c$ units) about $-6.5j$. Consideration of page 109 shows that for a reactance of 6.5, the maximum possible absorption coefficient, α_{nf} is about .26, and (as is true for all large reactances) to obtain this maximum value, the resistive component must be about equal to the reactive component, actually about 7. Right here we see the first limitation on obtaining a high absorption coefficient at low frequencies, that is, in the cavity depth allowed. If a 6" cavity were allowed, an α_{nf} of .48 would be obtainable at this frequency, with a corresponding resistive component of about 3.4

Returning to the 3" cavity, for optimum absorption, at 110 c.p.s. we want an impedance of $(7-6.5j)$. The real part must come from a flow resistance of about 7, which has shunted across it a reactance from Eq. (4) of $\frac{+j\omega m_1}{\rho c}$. From the tables giving flow resistances, Felter's 1/2" White Felt would be suitable, except that its shunt inductance at this frequency ($m_1 = .1 \text{ g/cm}^2$) is only $(+1.7j)$. The resulting impedance of the structure is about $(0.4 - 4j)$ so that by no means is optimum absorption achieved. To make this particular felt effective, it must be "loaded", perhaps with expanded metal or

heavy screening, to increase its surface density to be at least equal in magnitude at our chosen frequency to the flow resistance. That is, the density should be at least 0.5 grams/cm^2 in order to achieve optimum absorption. Examining the circuit shows that a given frequency some shunt reactance across the flow resistance is helpful, because it balances out part of the negative spacing reactance. This is true, however, only at the lower absorption cut-off frequency. Rather than load such a thin material, it would be better to use a thicker material with lower flow resistance per unit thickness, such as two or three inches of glass wool. The reason for this is that at higher frequencies the spreading out of the dissipation gives less sharp resonances and a more uniform absorption characteristic.

Weight is the second practical limitation in the design of low frequency absorbing structures. The necessary surface density of $.5 \text{ g/cm}^2$ for optimum results at 110 cycles is about 1 lb/ft^2 , which is pretty heavy for airplane treatment. With a 6" cavity, the corresponding density would be about 11 oz/ft^2 at 110 cycles. In other words, for 110 cycles we can obtain about twice as much absorption with two-thirds as much weight of material merely by changing the material spacing from 3" to 6". The necessary weight for the best absorption at 55 cycles for a 3" spacing would be a lb/ft^2 , and the maximum absorption would be only half as great, i.e., $\alpha_{nf} = .13$.

The above example serves to point out the limitations of present weight and space restrictions on obtaining optimum sound absorption at low frequencies. The table of densities and flow resistances show that very few of the materials as now used are suitable for optimum sound absorption. Most of the felted materials have too low a ratio of surface density to flow resistance to be useful at low frequencies; while most of the glass, mineral and kapok wools do not have sufficient flow resistance unless used in multiple layers. We refrain from listing "absorption coefficients" for the materials, because, as has been pointed out earlier, the absorption is not a characteristic of the material alone but of the complete structure.

Another serious limitation lies in the method of mounting the spaced material, particularly where it is desired to utilize flow resistance with $R/\rho c$ greater than one and to have the material easily removable for inspections and emergencies. For if the material is mounted in small panels with snap or other fasteners which do not effectively seal the edges, air will be "pumped" through the cracks rather than through the material, thus finding a short-circuit path across the resistive element of the equivalent circuit. It is suggested that the materials be mounted in as large panels as practicable with further investigation on methods of effectively closing up the joints. Possibly a "zipper" fastener on the trim cloth covering would provide a sufficiently good seal,

while snap fasteners attach the materials to the fuselage struts.

As a check on the theory a large number of materials were tested spaced out at various distances from a rigid wall. The values of the acoustic impedances of these structures are tabulated in the graphs on the following pages. Photographs are shown in Figs. 2 and 3, page 129, of part of the apparatus used to make these measurements.

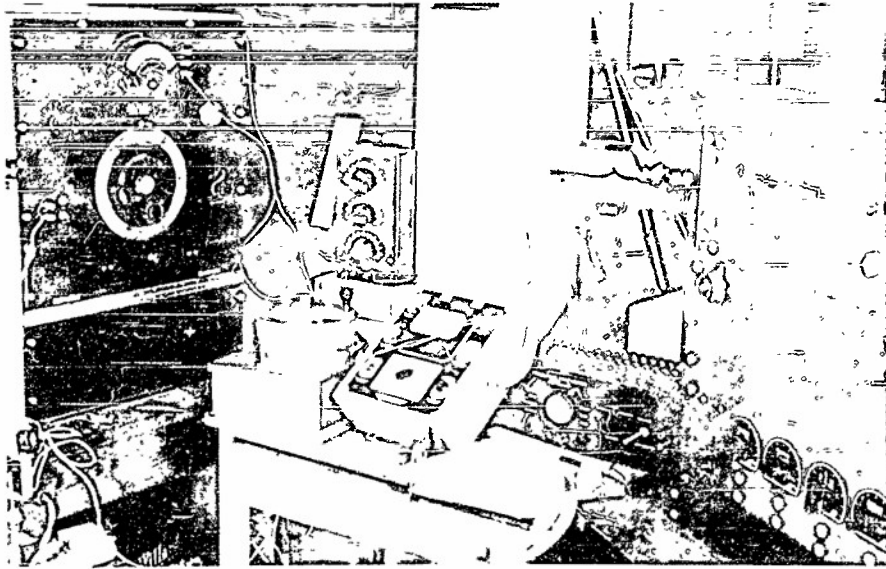

Fig. 2. Electrical components used in acoustic impedance apparatus.

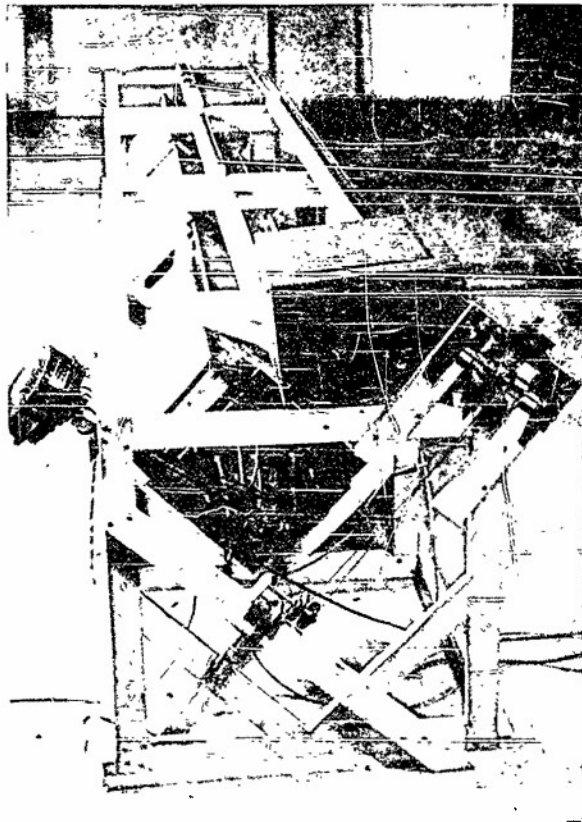
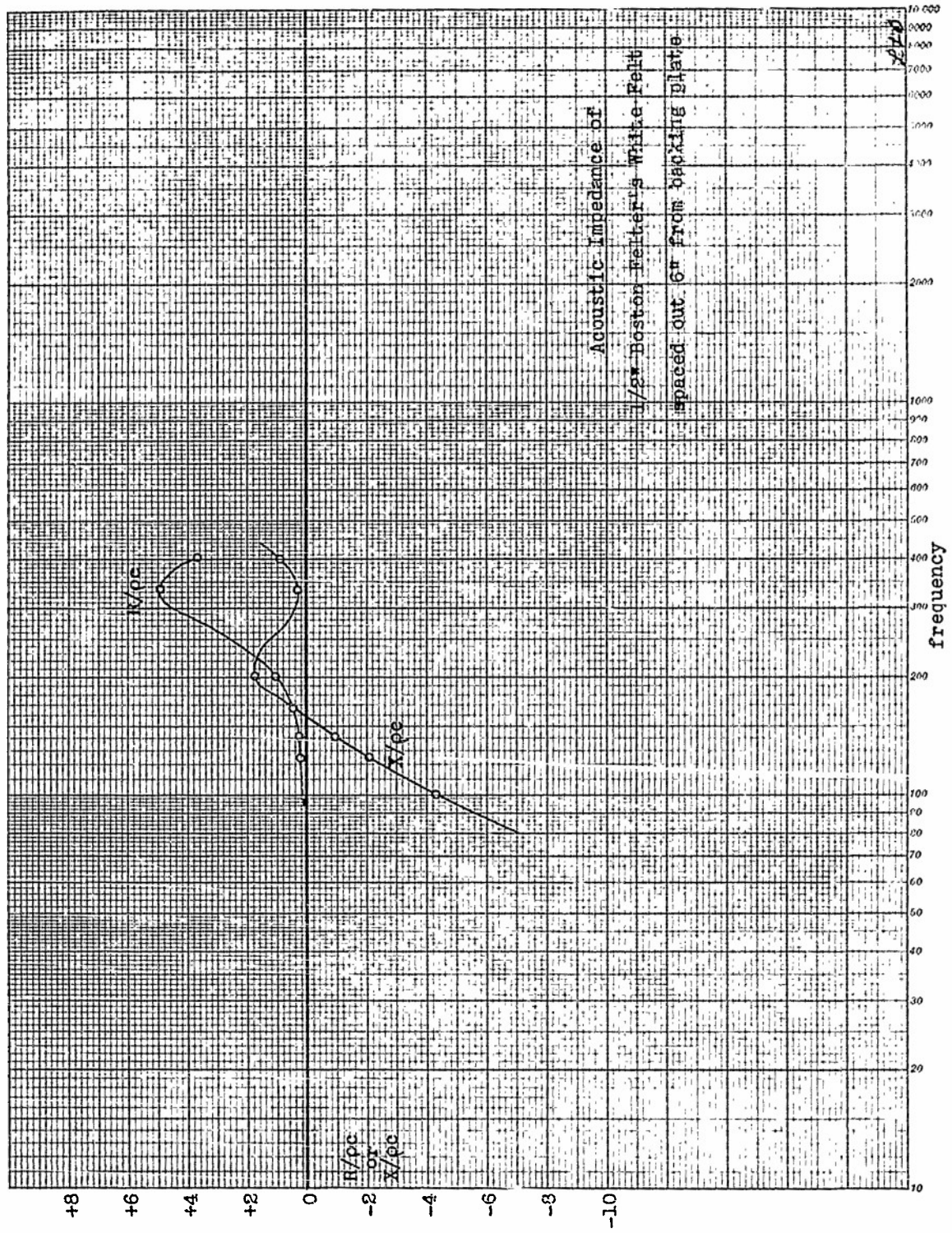
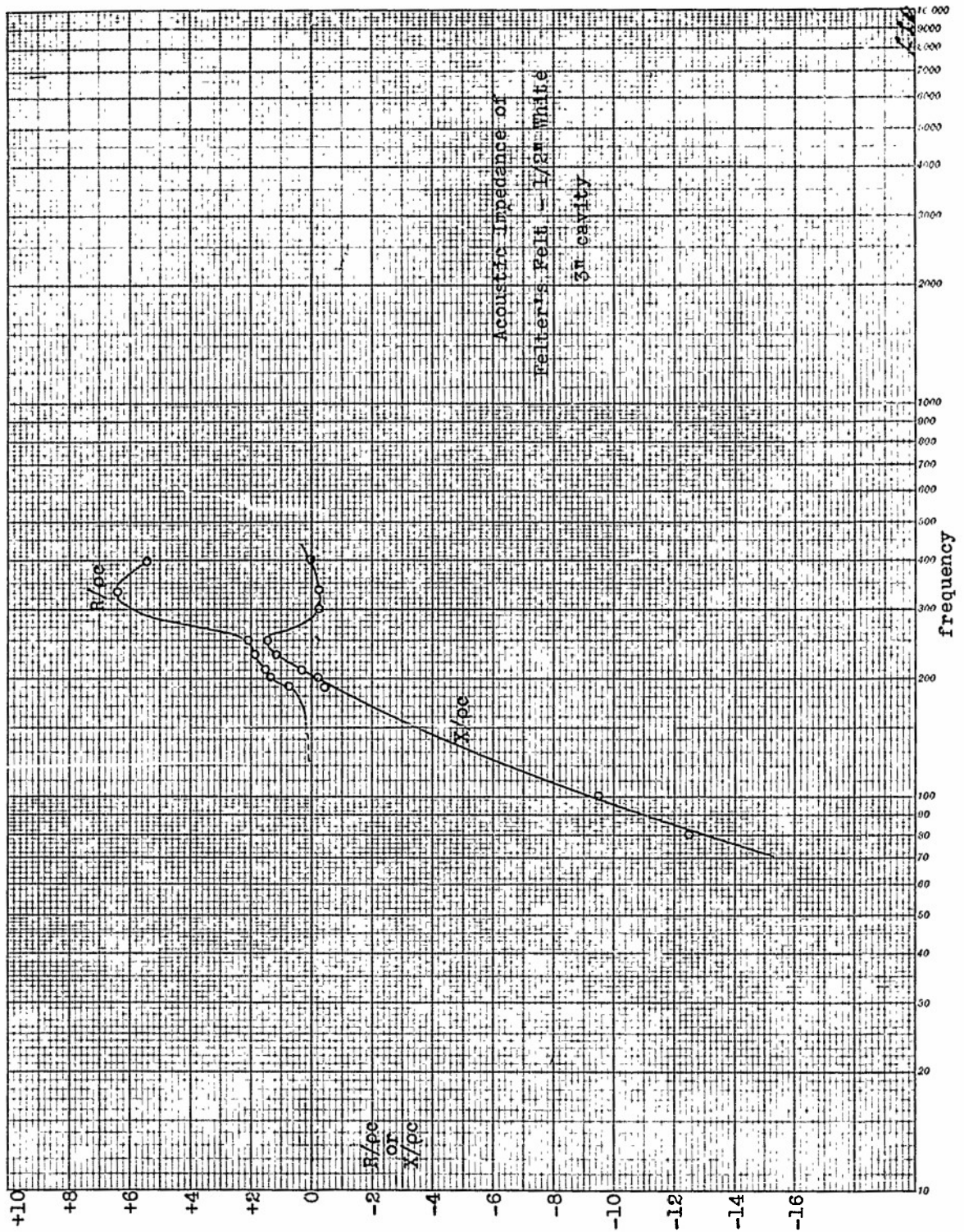
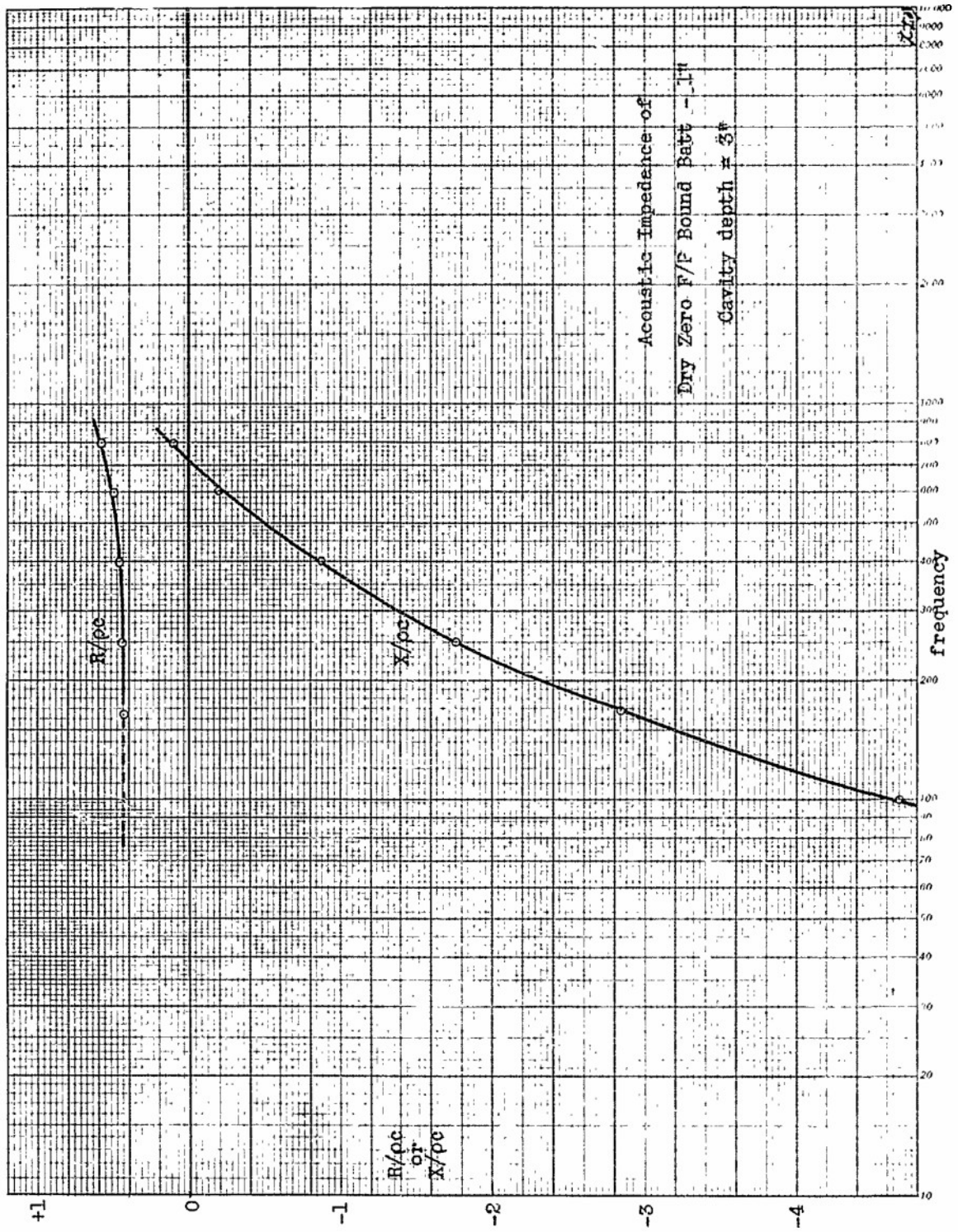
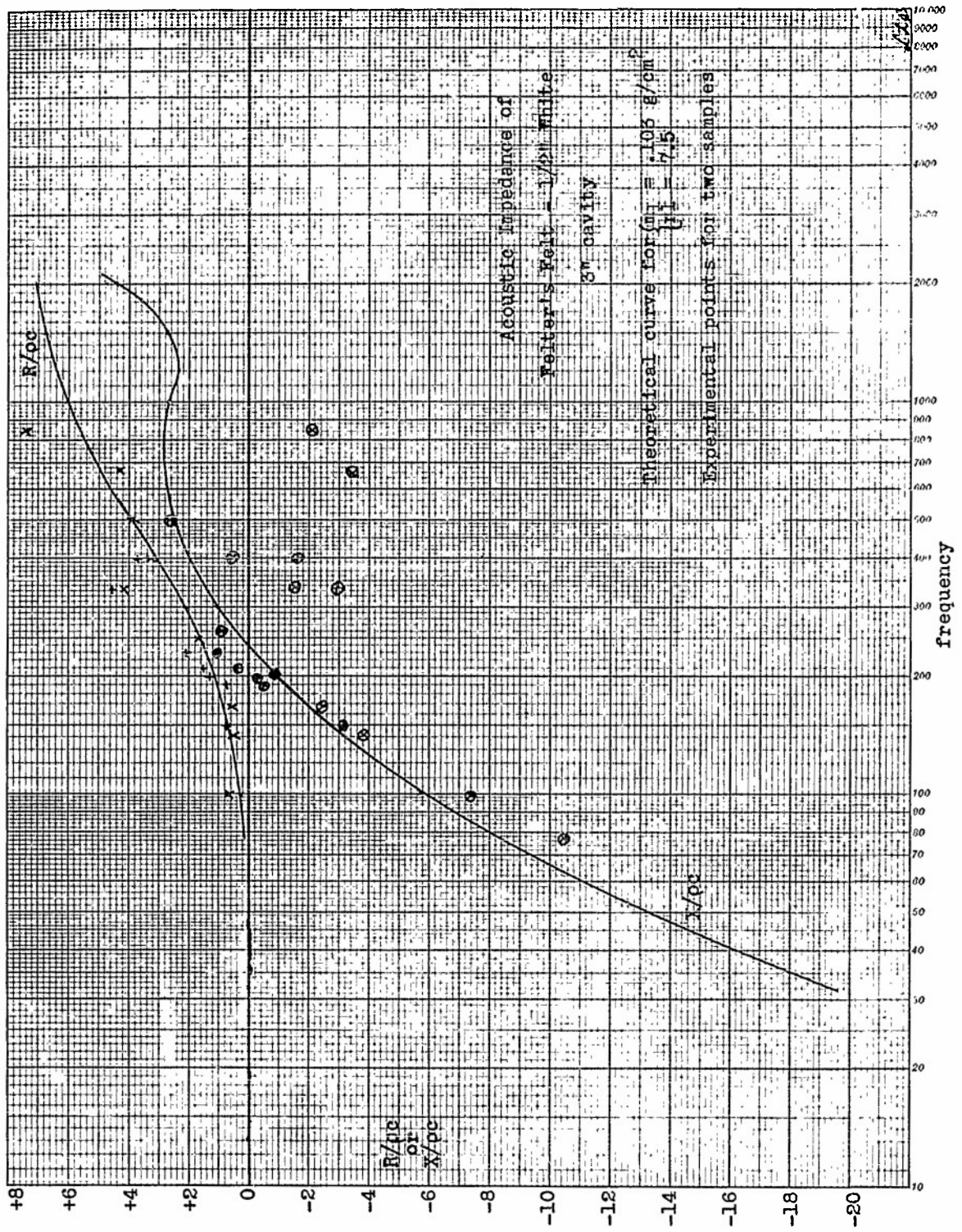

Fig. 3. Apparatus for measuring the acoustic impedance of 8" square samples.









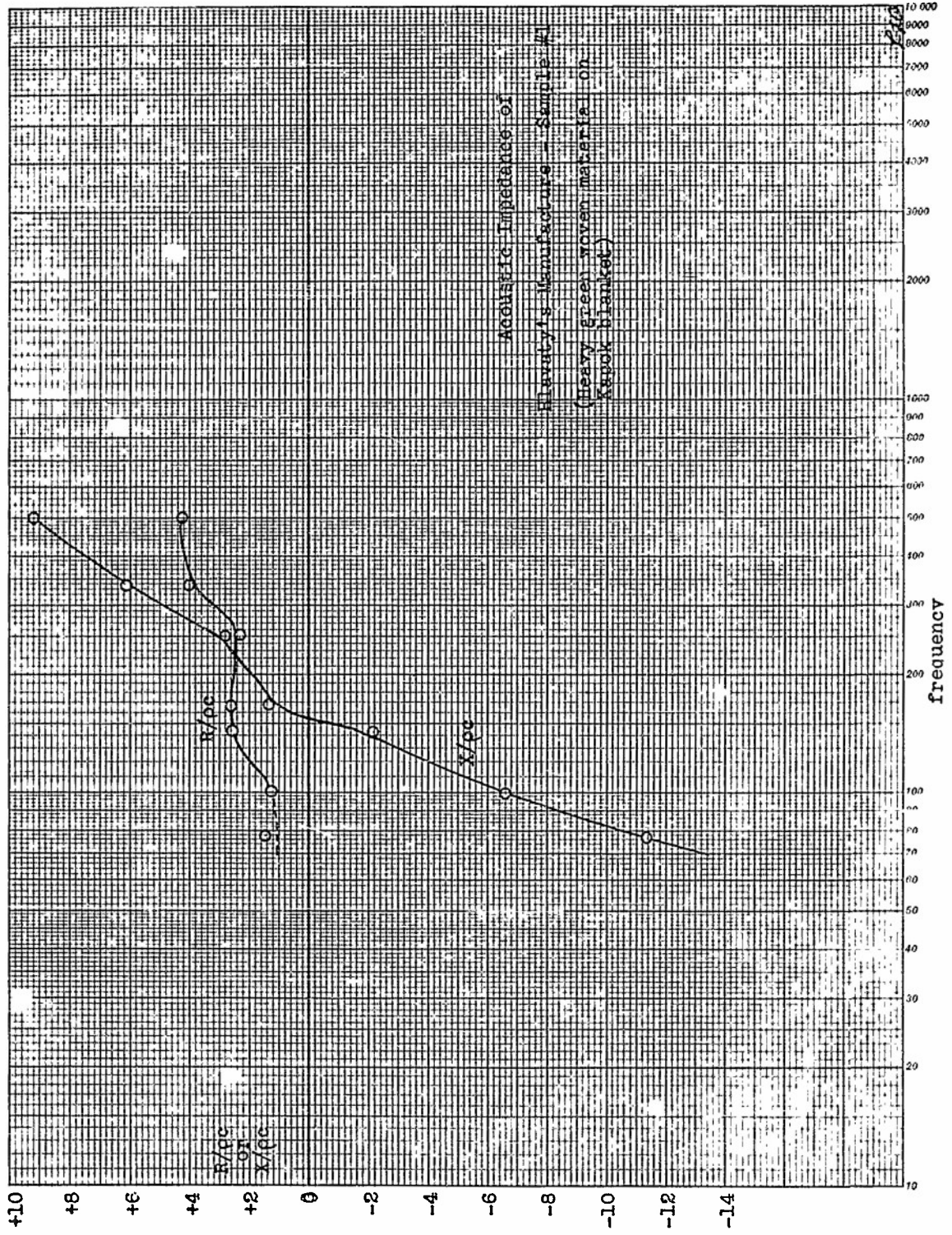

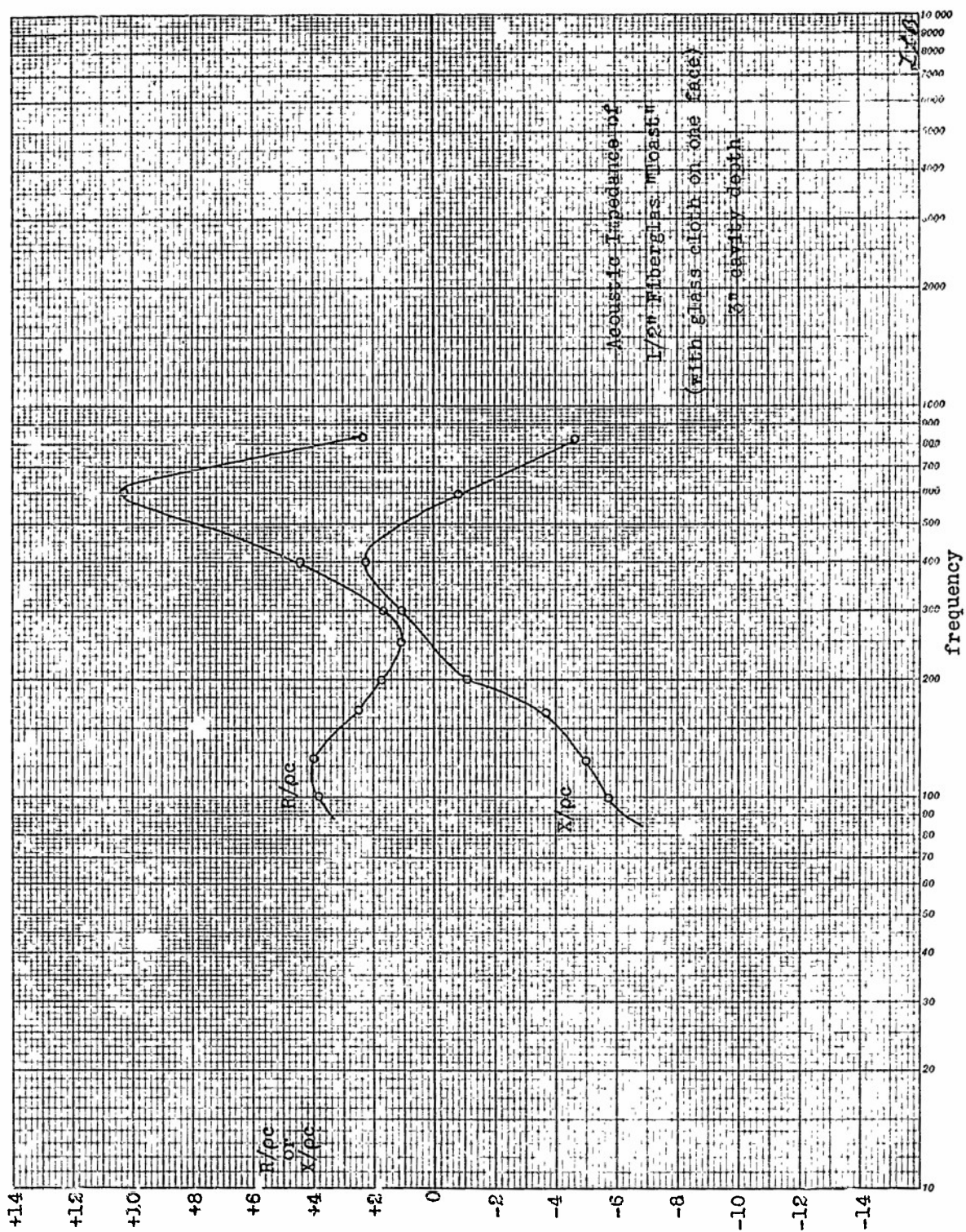

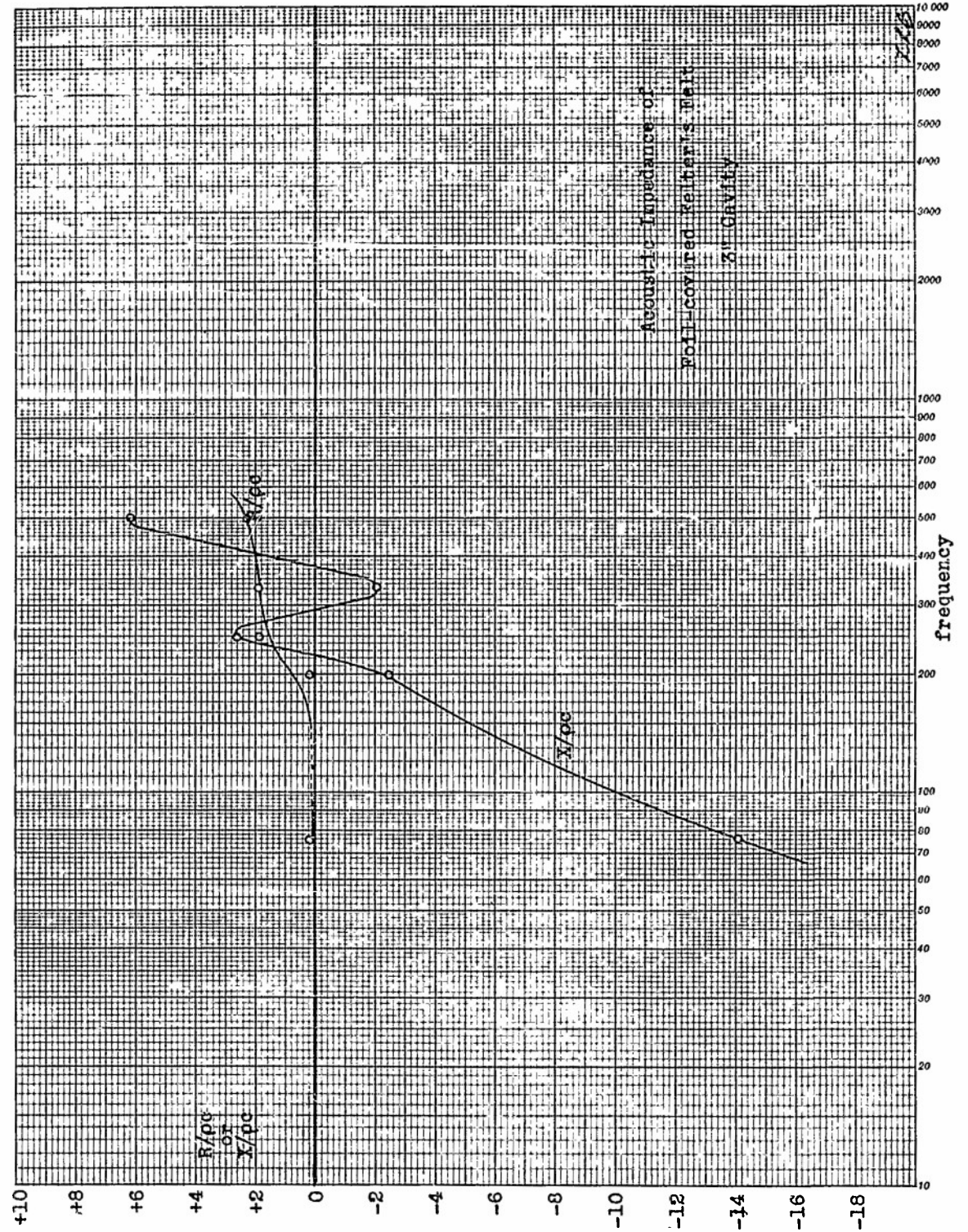

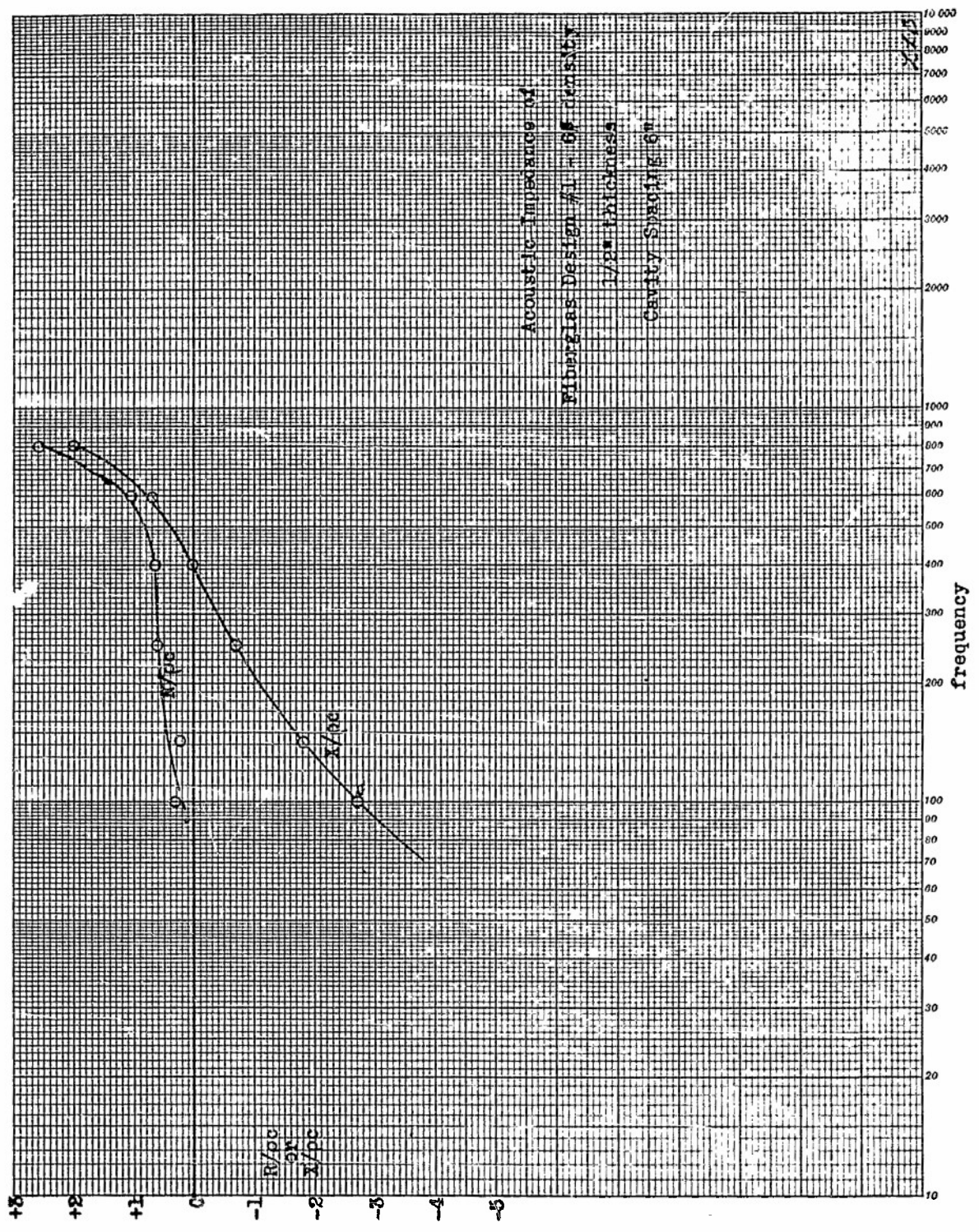

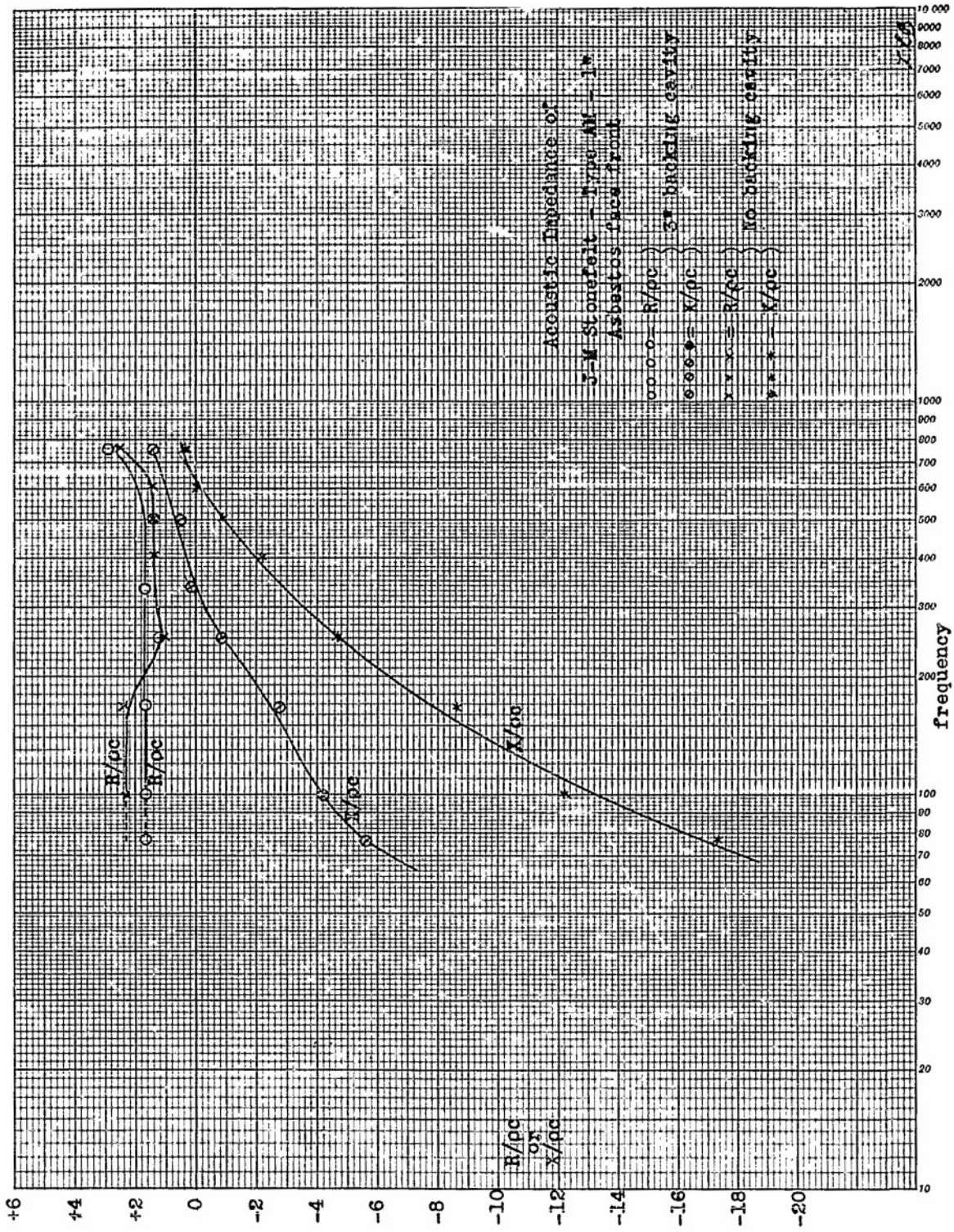

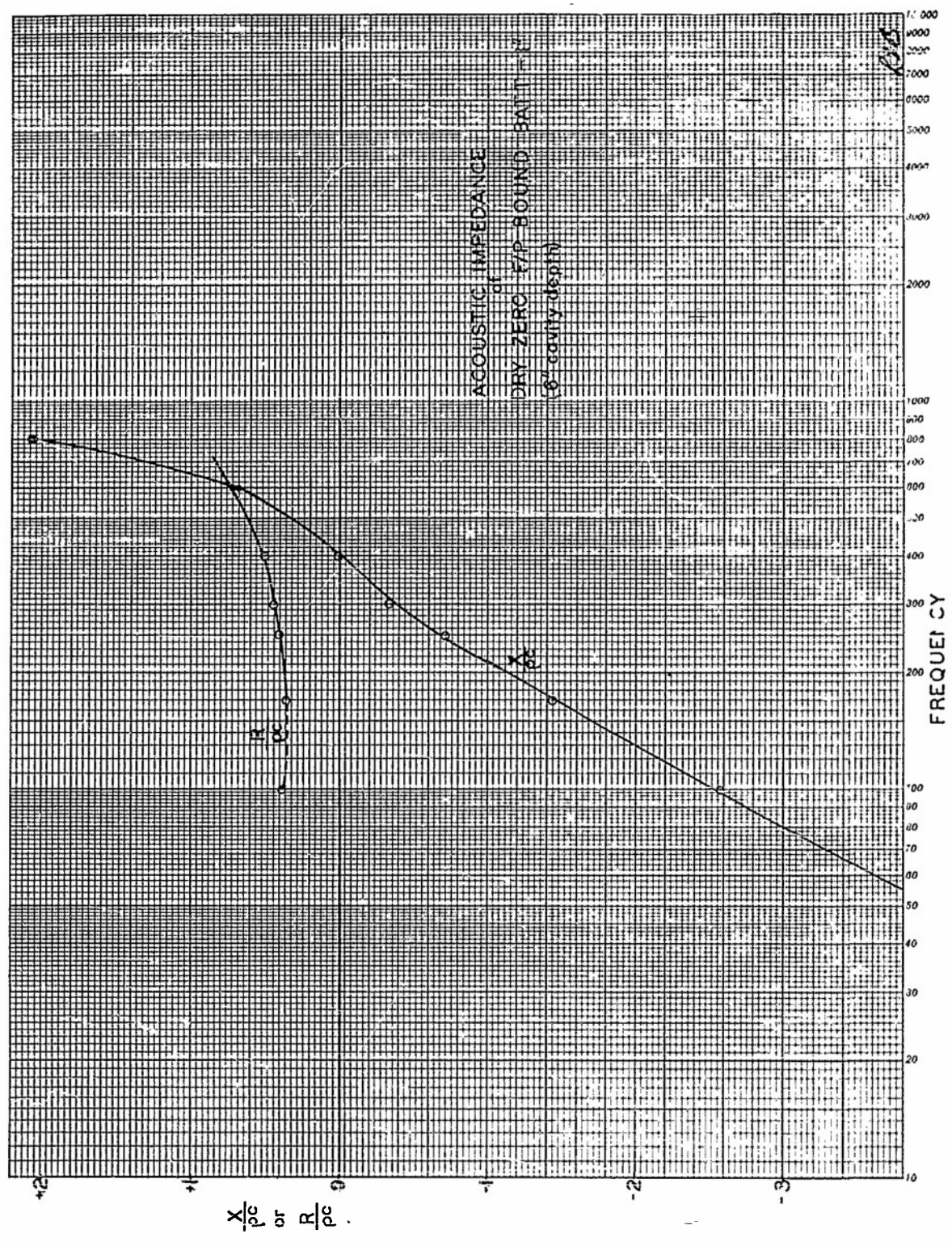

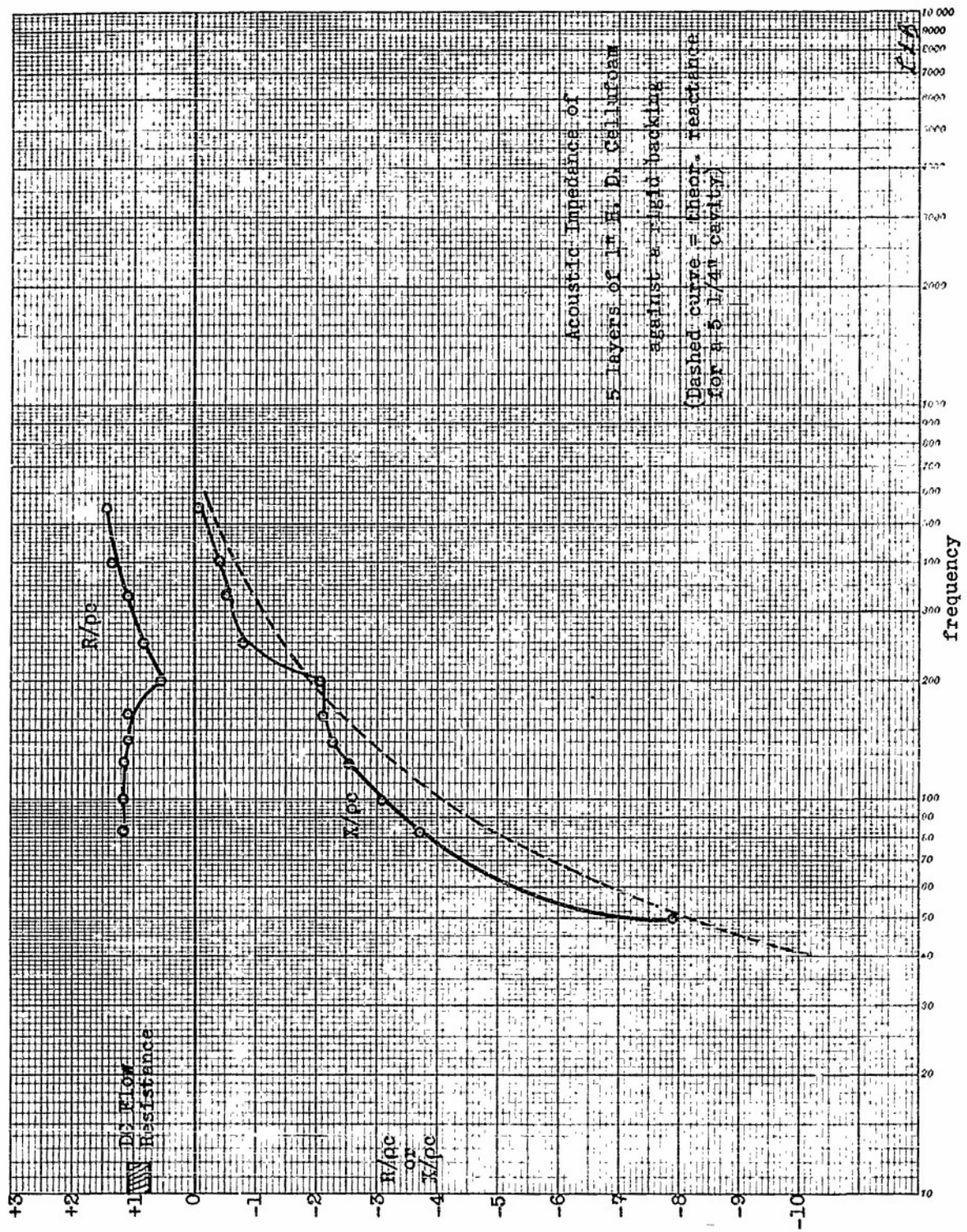

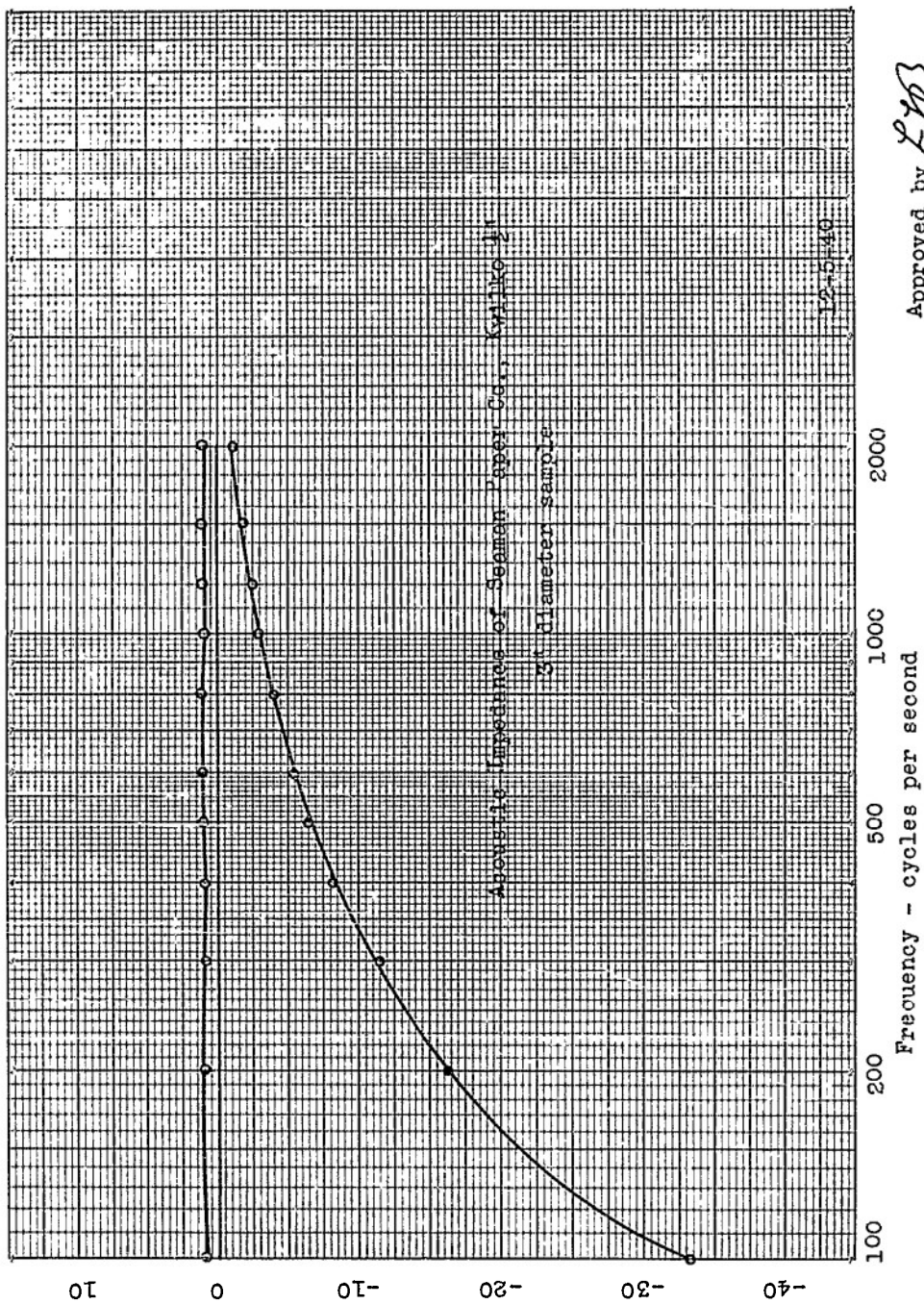

Approved by L. J. G.

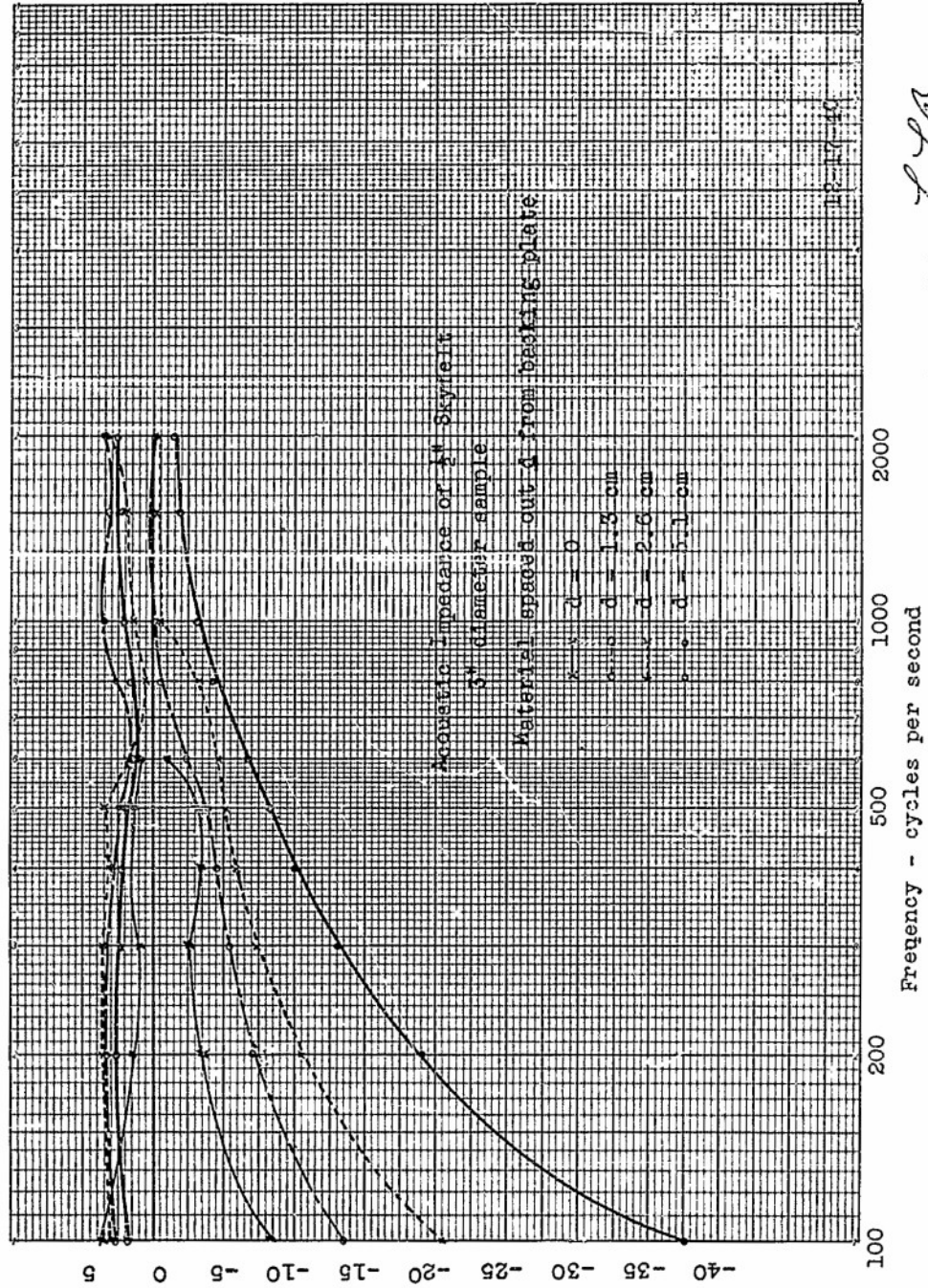

Approved by *LLO*

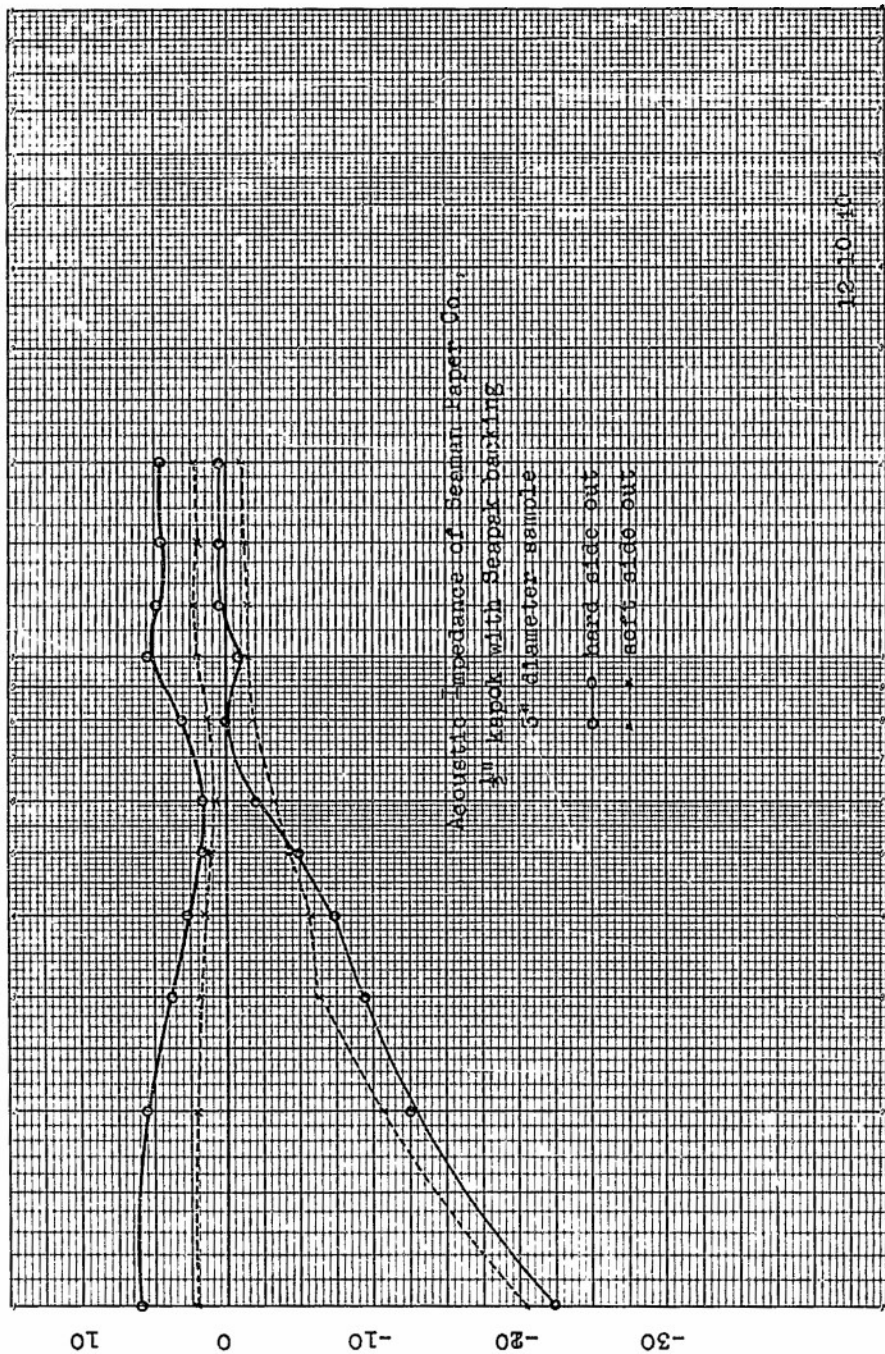

Approved by LFB

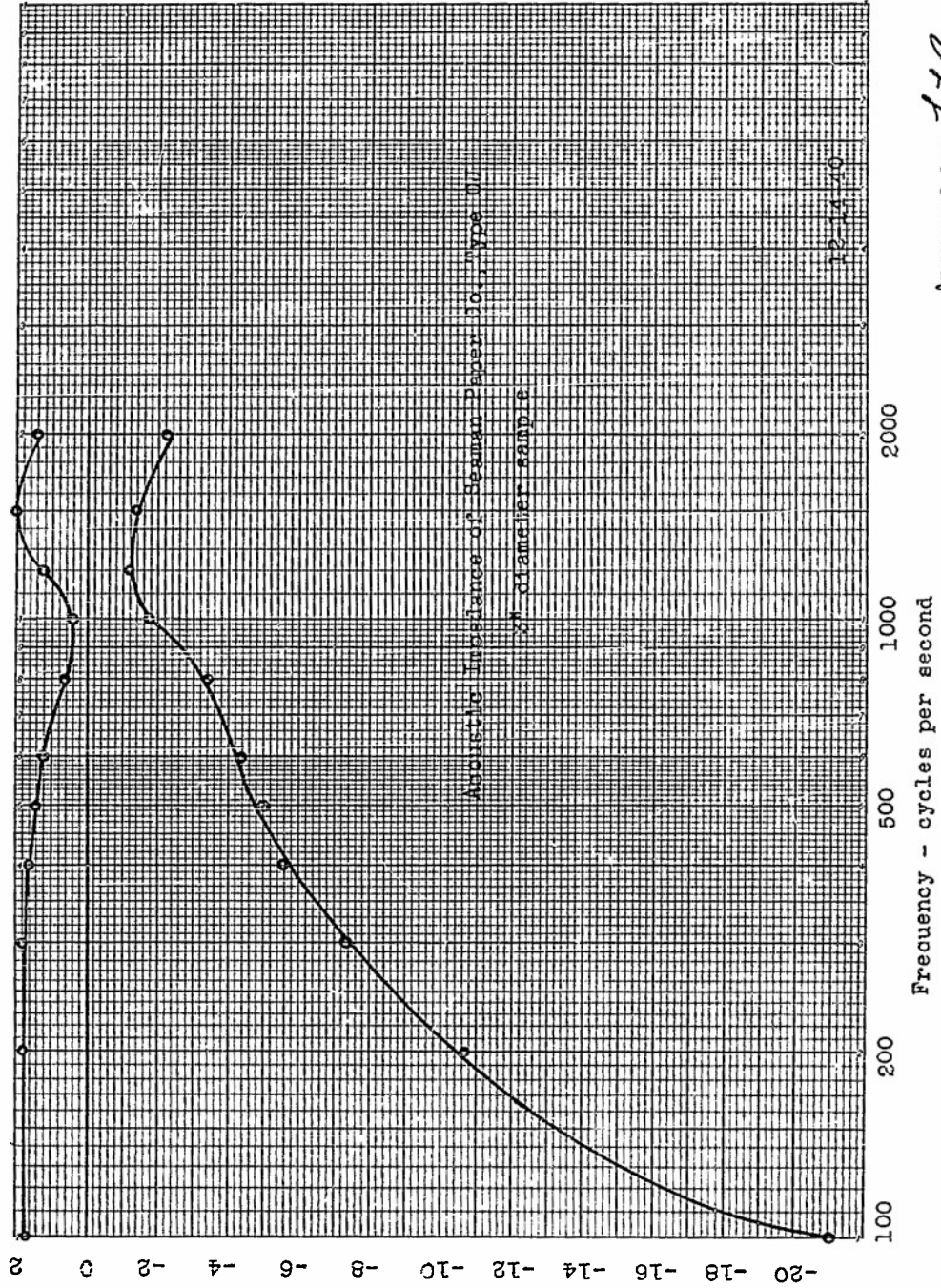

Approved by ZTB

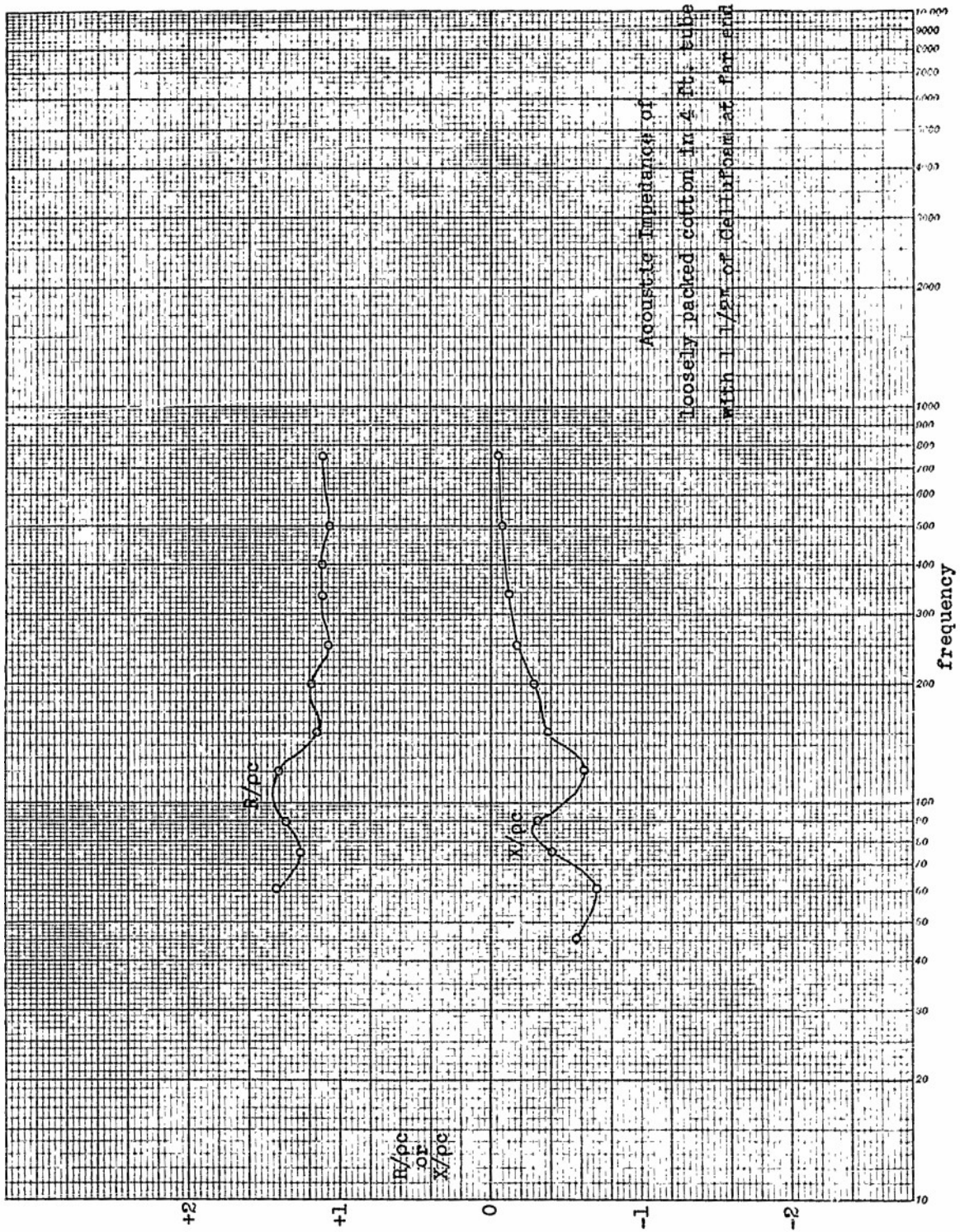

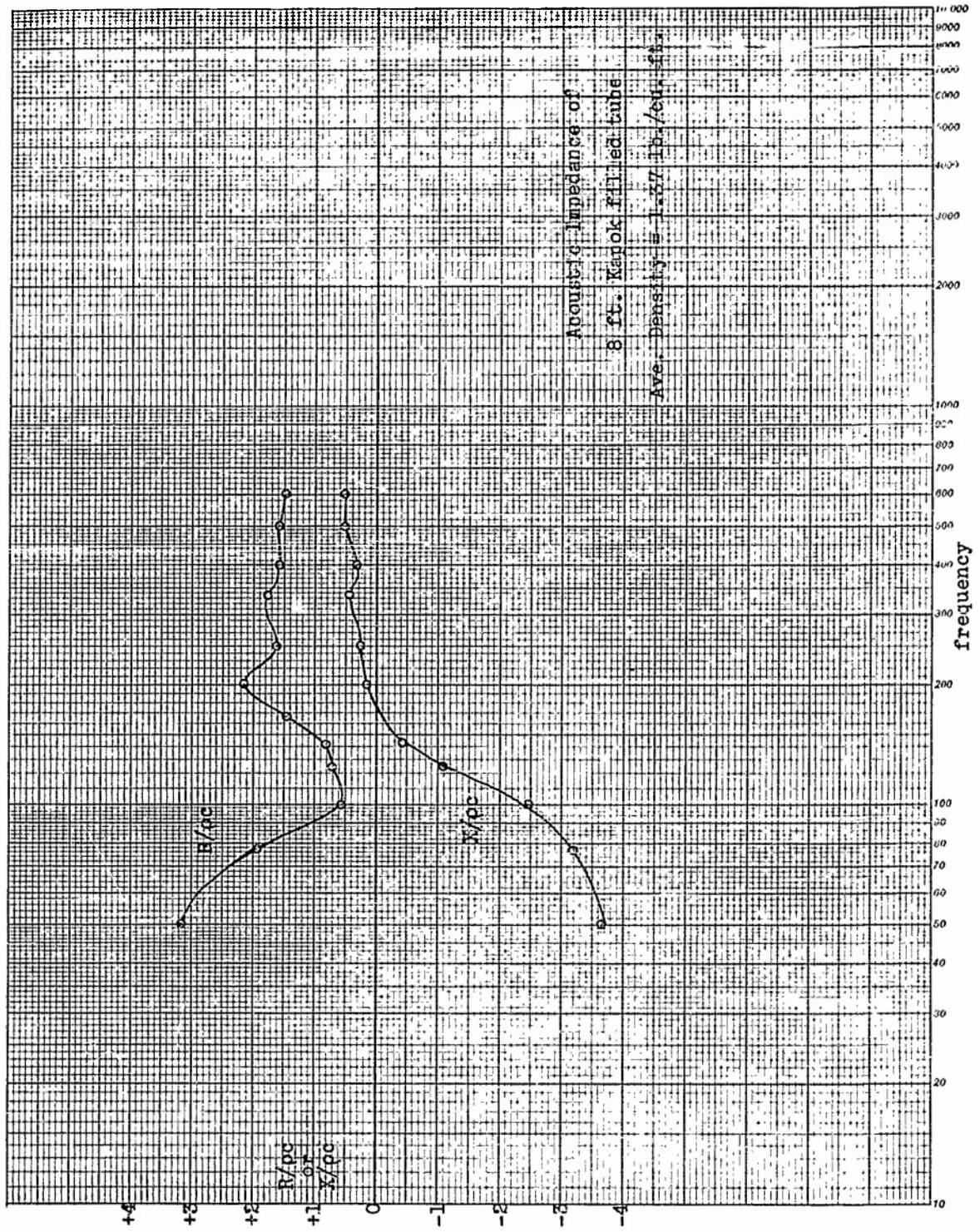

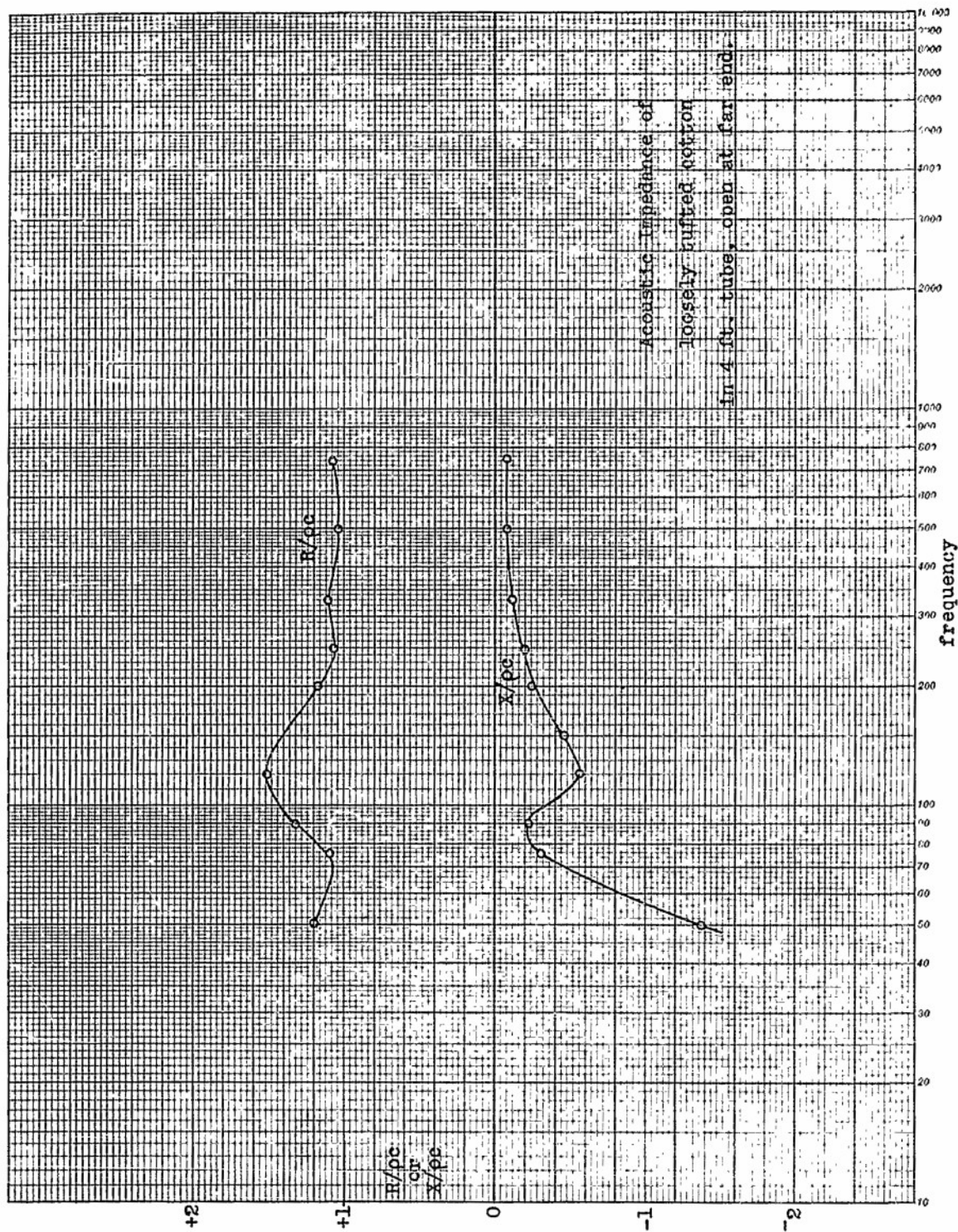

PANEL TRANSMISSION

a. Introduction

One of the most important ways of attacking the problem of sound reduction in aircraft is to reduce the transmissibility of the fuselage walls. In order to attack this problem intelligently, it is necessary to set up some sort of experiment which will measure the transmission of a panel both with added materials and without. In the past the standard method of measuring transmission has been to mount the panel in a wall separating two rooms. A source of sound is then placed in one room and an "average" pressure over the face of the panel determined by measuring the output of either one rotating microphone or the commutated outputs of a series of microphones placed at various points. Elaborate methods are employed to approximate a diffuse sound field in the source room. The second room is usually well treated acoustically such that standing waves are somewhat suppressed. The sound level in that room is measured by the same means as for room 1. The simple theory says that if the average sound level is measured in each of the two rooms the Transmission Loss of the panel may be defined as follows:

$$\text{Transmission Loss} = L_1 - L_2 + 10 \log_{10}(S/A_2)$$

where

L_1 = the average sound level in decibels in room 1, the source room.

L_2 = average sound level in decibels in room 2, the receiving room.

S = total area of sound transmitting surface

A_2 = total absorption in room 2, A_2 measured in same units as S .

It has long been recognized that the use of such an experiment leads to large inaccuracies. This follows because it is impossible to obtain, especially at low frequencies, a truly diffuse sound field in room 1 over the face of the test panel and it is difficult to estimate the true absorption or to measure accurately an "average" pressure in room 2. Descriptions of this method and ways of reducing these errors have been presented by several investigators of the National Bureau of Standards.

b. Apparatus

To avoid these difficulties and to permit careful examination of the panel to see which portions of it transmit sound most freely, it seemed to use advisable to devise an experiment

free from many of the assumptions made in the older experiments and offering the possibility of obtaining continuous pressure versus frequency transmission curves.

On page a sketch of the experimental apparatus which we are now using is shown. It will accommodate sections of fuselage in sizes up to four feet square. The panel under test is mounted in an horizontal position in a frame and sealed in place such that no air can circulate around the edges. A bank of sixteen loud speakers acts as the driving source of sound and is placed as close to this panel as possible. The large number of loud speakers plus their proximity to the panel tends to build up a uniform pressure over the entire face of the primary side. The secondary side of the panel is terminated by a kapok filled tube eight feet in length and subdivided into a number of small cells such that transverse standing waves can not exist below a certain limiting frequency. This kapok filled tube acts as a very highly absorbing termination and essentially takes away all the sound transmitted through the panel. If, then, one measures the pressure on the primary side and the pressure on the secondary side, one gets a measure of the transmission of the panel for the definite case of a termination whose impedance is known. It is quite obvious that if the panel were terminated in some other manner reflections would take place and a different pressure would be recorded on the secondary side. One advantage of our experiment is that the properties of the termination are known and are reproducible in another laboratory. Thus we have eliminated one important source of error by doing away with the indeterminate treated room 2. A second advantage is that this apparatus gives us a more definite knowledge of the pressure on the primary side.

The photographs shown in Figs. 6 to 13 give the structural details of the experimental set-up. The sixteen loud speakers shown in Fig. 6 are screwed into a supporting frame. The side walls of this frame are four inches thick and are filled with beach sand to prevent sound from the backside of the loud-speaker from getting around to the front. A number of microphones are mounted in the space just above the loud speaker to measure the sound pressure at various points over the surface of the panel. Fig. 7 shows a section of fuselage cut from a Douglas DC4 airplane mounted in a frame and placed over the bank of the loudspeakers. The two braces seen in Fig. 6 just inside the outer speakers are added to the set-up when this particular small section of fuselage is used and bolted rigidly to the frame around the section. The frame is approximately four inches deep and is filled with a layer of 1.5 inches of beach sand to reduce the possibility of sound transmission from the loud speaker through it to the termination above. To further reduce sound transmission through this particular panel, the outer eight speakers are usually

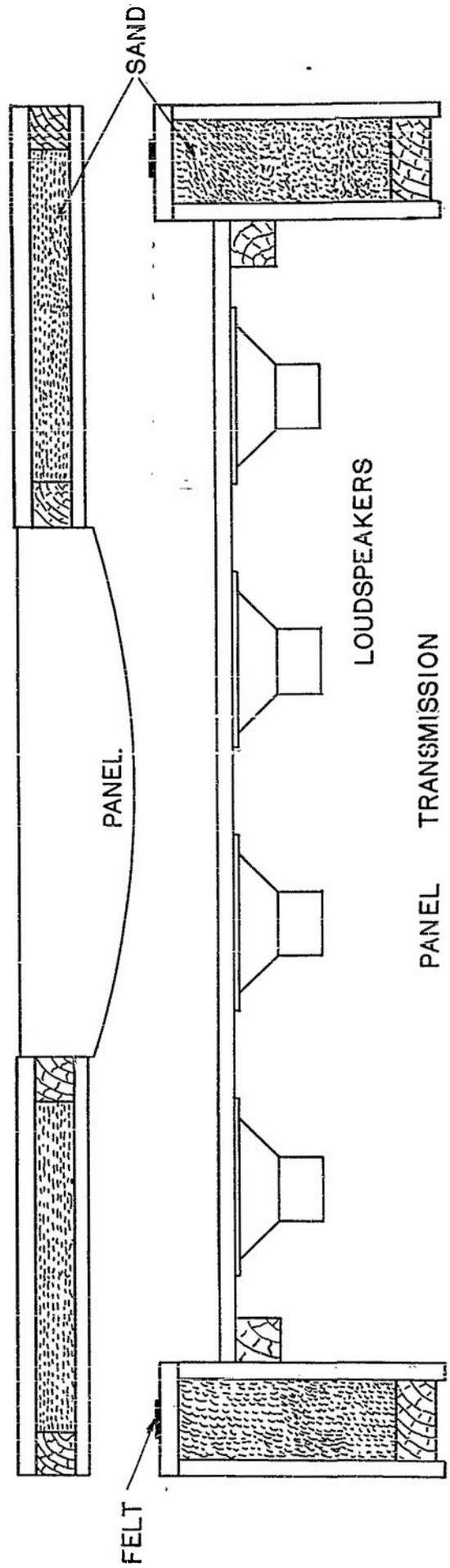
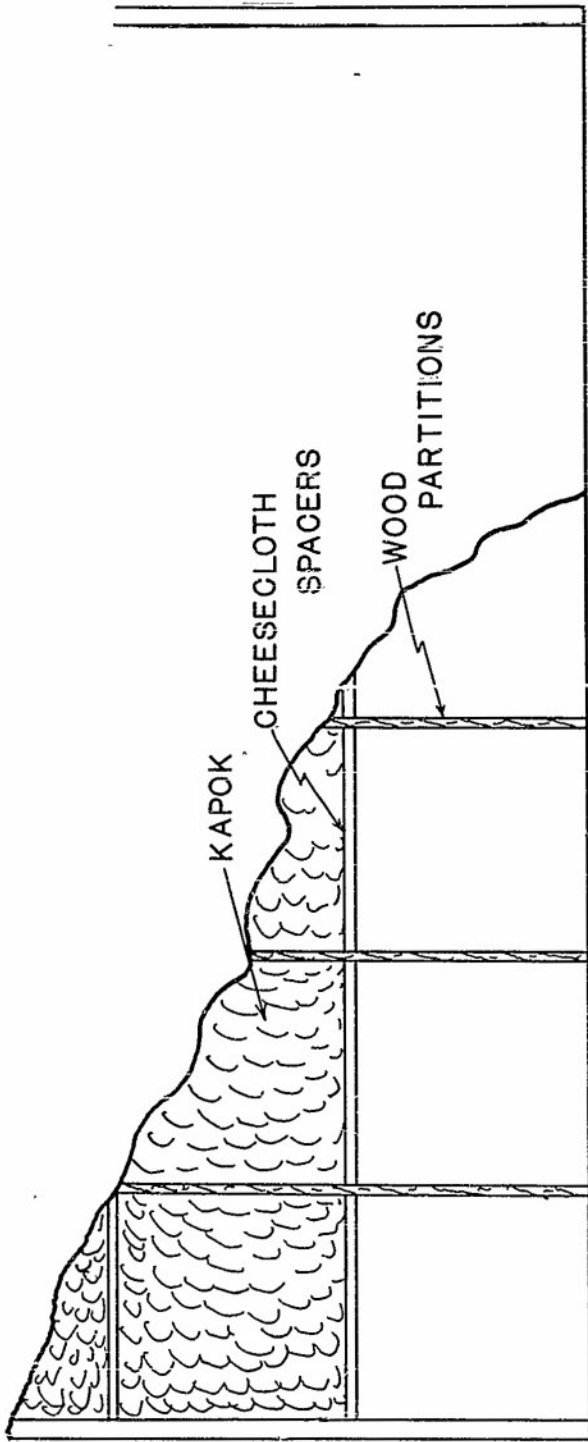

APP. L. Beards
 199

disconnected. A larger panel built by Consolidated is shown in Figs. 8 and 9. When testing this, the two braces on the speaker baffle are removed and the sixteen loudspeakers used.

Structural details of the highly absorbing termination are seen in Figs. 10 and 11. The "egg-crate" construction is continued to the top of the tube, except that the number of squares is reduced. The termination is designed to have low input impedance up to about 1000 cycles, as can be seen from the measurements plotted on page 181. Microphones for measuring the pressure of the transmitted sound are mounted in several of the squares; two of the cables can be seen in Fig. 10.

A chain hoist is used to lift the termination or the frame when changes are being made. The total weight of the termination is about one thousand pounds. The weight of a panel and sand filled frame varies between one hundred to two hundred pounds.

An automatic recording apparatus called the Audiograph (Fig. 13) is used to plot directly sound pressure in decibels versus frequency. The outputs of the different microphones are connected to sockets in the sides of the wooden frame and termination and any one can be connected to the Audiograph. A sample record taken with this apparatus is shown on page 183. In taking this curve, the output of one of the microphones in the source side of the panel was held constant and the output of one of the microphones in the termination corrected to the Audiograph. The Audiograph curve is, therefore, a direct plot of the transmission of sound through the panel.

c. Experimental Results.

The analysis of the transmission of sound from the outside of an airplane fuselage to its interior is a very complex problem, and one which does not yield easily to mathematical treatment. A typical construction of the fuselage is that of a thin dural skin stretched over formers of various shapes and sizes. If such a structure is set into mechanical vibration in some way, it will show a number of resonances at which the amplitude of vibration, for a fixed driving force, is much greater than at other frequencies. In particular, if a sound field of constant pressure is applied to one side of a section, or panel, taken from a fuselage, the sound pressure measured on the opposite side of the panel is found to fluctuate widely as the frequency is changed. At each frequency for which the panel has a mechanical resonance, the drop in sound pressure through the panel (transmission loss) will be very much less than at other frequencies. At a resonant frequency the transmission loss through the panel depends upon the area of the panel which is vibrating at that resonance, and upon the mechanical damping which is in effect. The resonance of the panel which has the lowest frequency is generally the one which has the

least transmission loss. The frequency of this lowest resonance depends upon the shape and size of the section of panel which is vibrating, as well as upon its construction. In general, a panel will show a great number of resonances, some of them sharper and of greater magnitude than others.

In view of this complicated behavior of the panel, it is difficult to apply a very thorough mathematical treatment to it. If only low frequencies are considered, where the resonances are well separated, it is possible to draw an electrical analogue for the panel. Such an equivalent electrical circuit is shown below. Each resonance of the panel may be

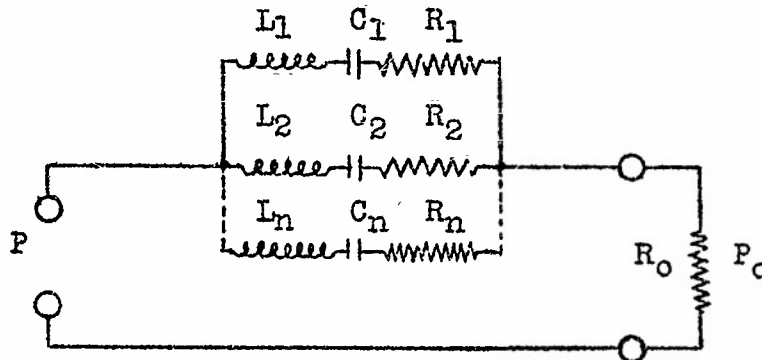

represented by a series resonant electrical circuit containing inductance, capacitance, and resistance. Obviously, there must be a separate electrical resonant circuit for each panel resonance, and if an attempt is made to carry this analogy to the higher frequencies it becomes unwieldy. If the transmission loss for the panel is known as a function of frequency, values for the elements in the equivalent electrical circuit may be computed. As discussed in the portion of this report on acoustical materials, similar equivalent electrical circuits may be set up for materials added to the inside of the panel in an effort to increase its transmission loss. Combining the circuits for the panel alone, and for the added material, gives a circuit for the panel and material together, from which the resulting performance can be predicted.

Thus far, in the course of measurements, data have been obtained for the two foot by four foot panel built by Douglas, the forty-two inches square panel made by Consolidated, and an experimental panel thirty-six inches by forty-two inches made from a strip of sheet dural. The Douglas panel has thin sheets of mica cemented over the whole interior surface of the skin, and is typical of the construction used by this company. The Consolidated panel is of especially sturdy construction used in pressurized cabins. This panel has a window ten by fourteen inches set into its center. The experimental panel is made of a sheet of dural, .04 inches thick, and is mounted so that its shape may be varied from that of a

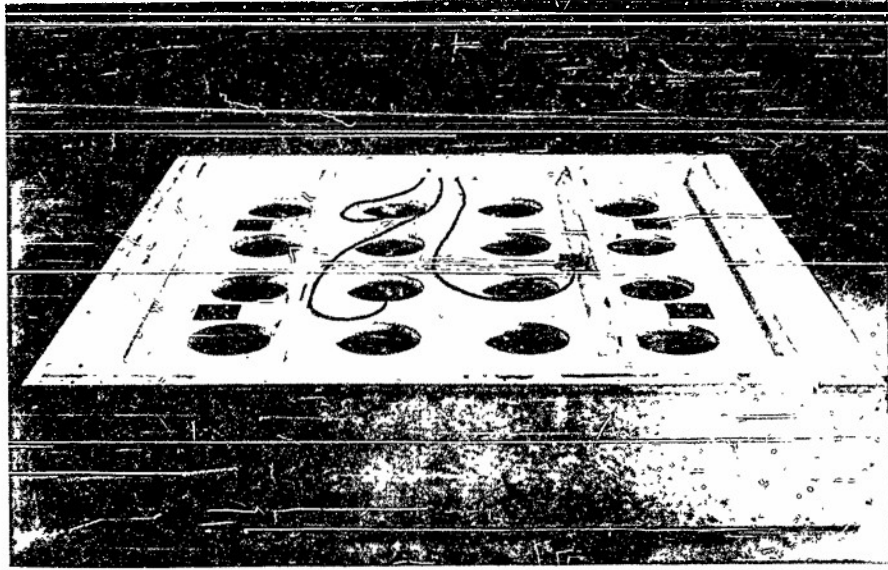

Fig. 6. Frame and speakers.

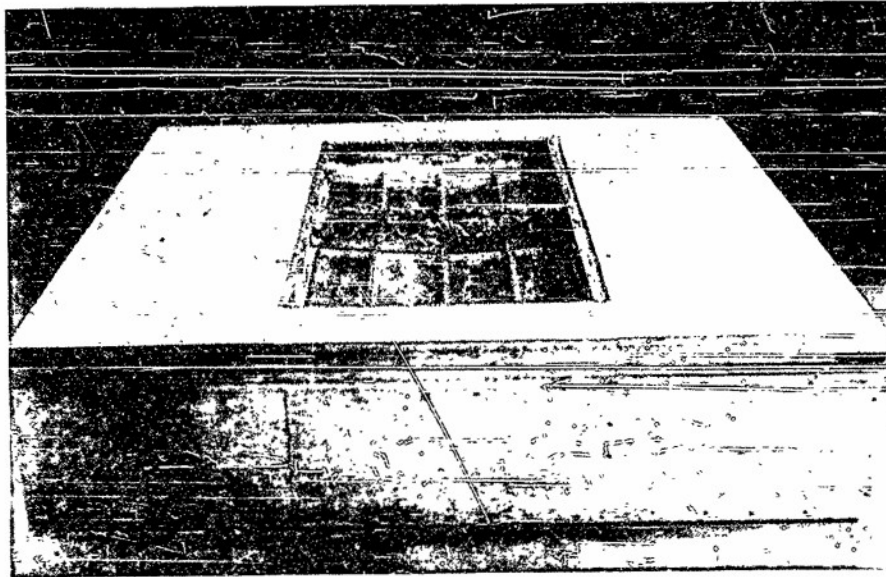

Fig. 7. Douglas panel.

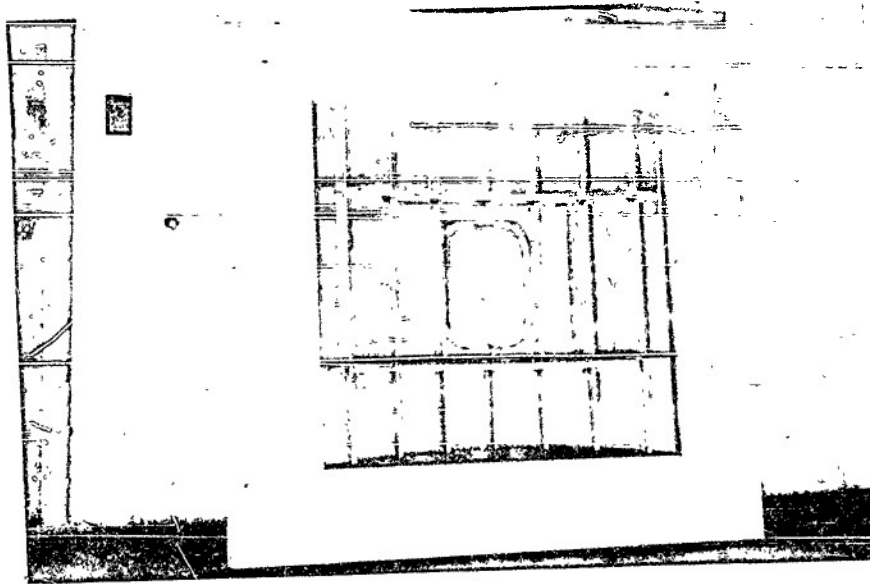

Fig. 8. Consolidated panel, inside view.

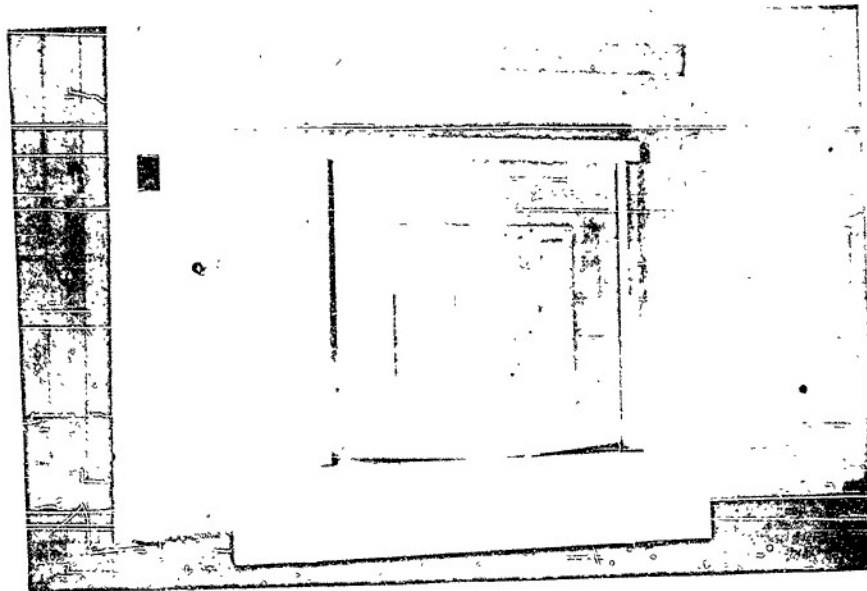

Fig. 9. Consolidated panel, outside view.

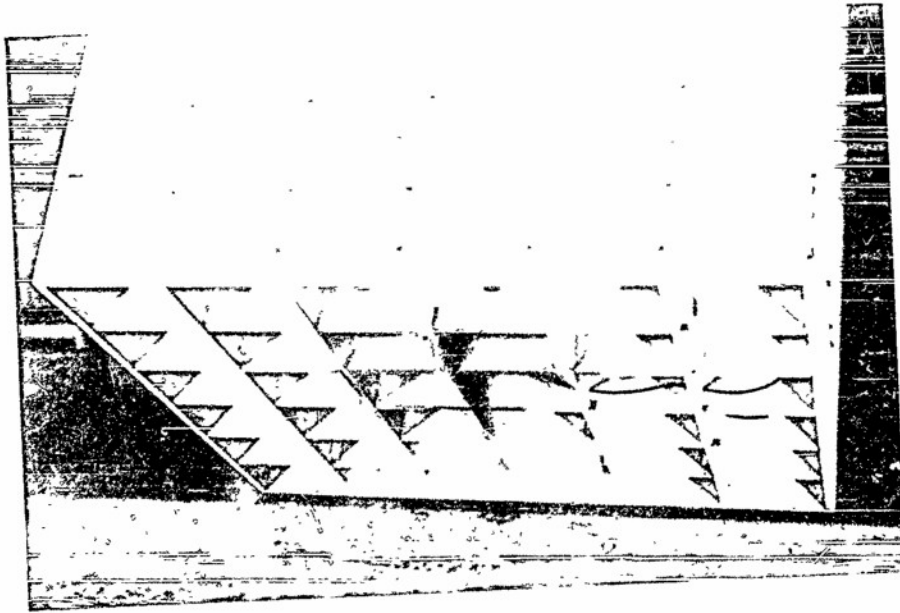

Fig. 10. Highly absorbing termination, bottom view.



Fig. 11. Highly absorbing termination.

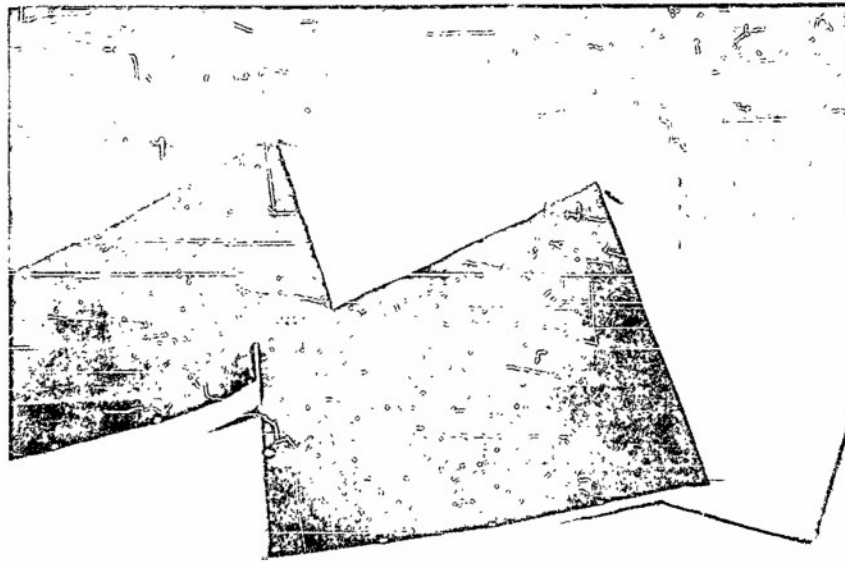

Fig. 12. Materials with snap fastener mountings.

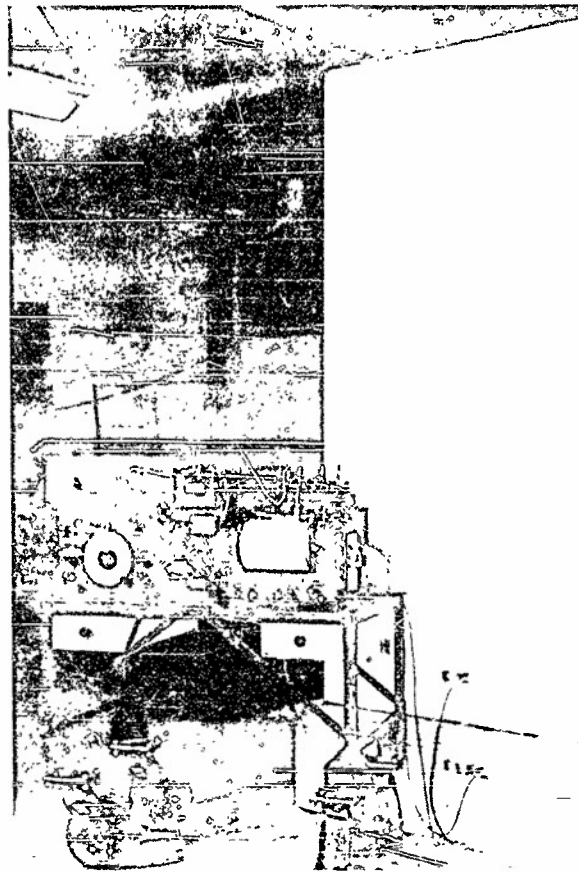
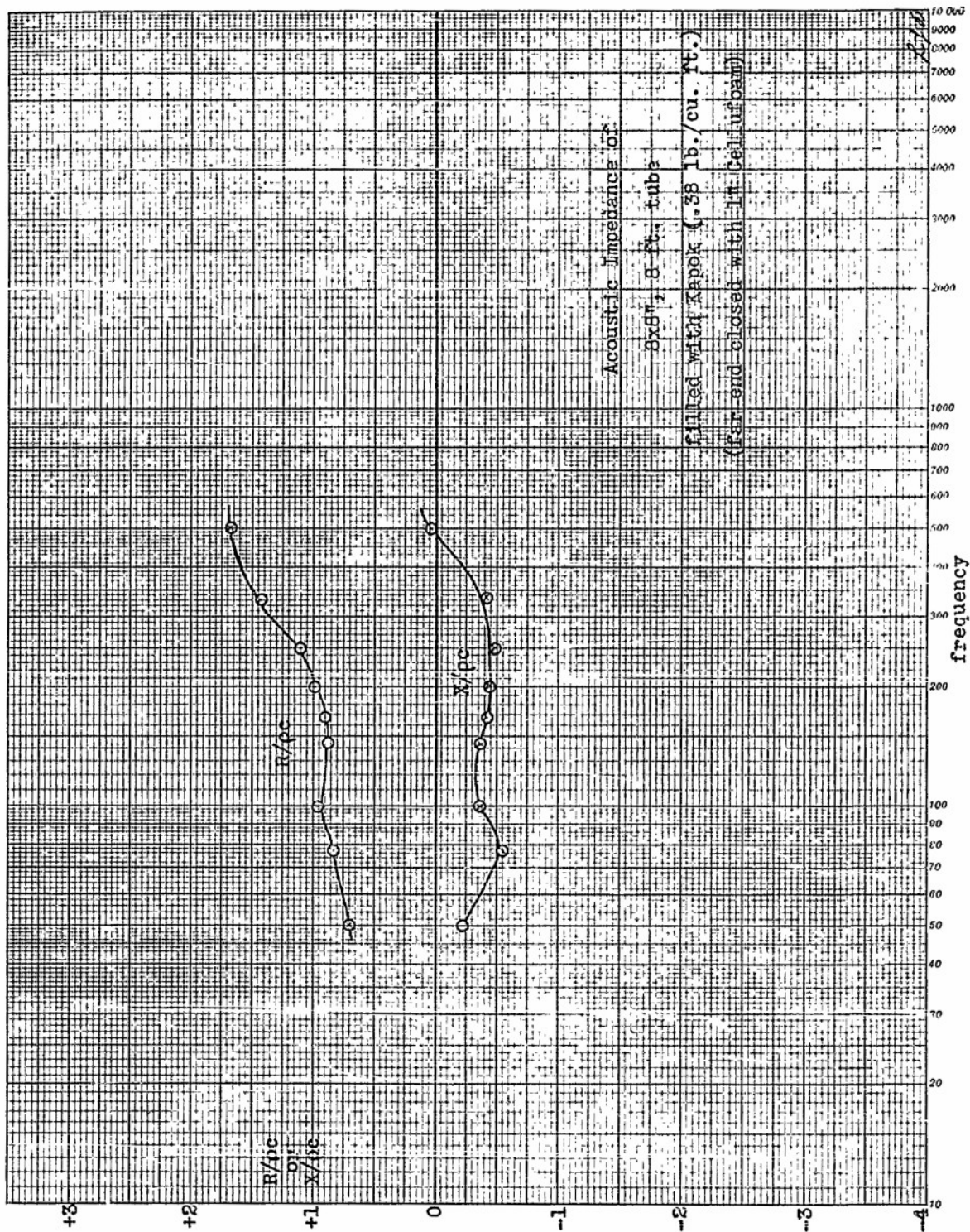
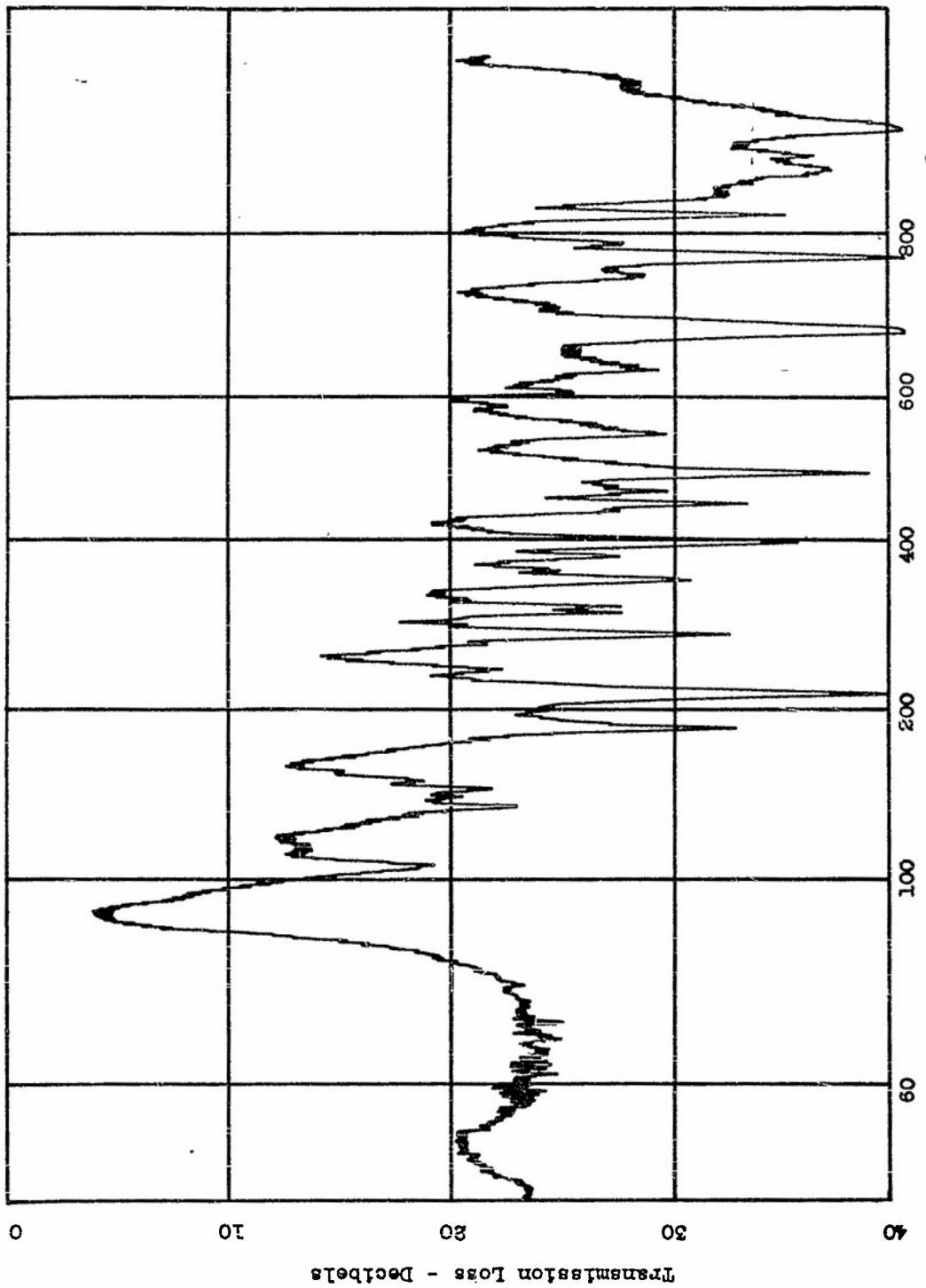

Fig. 13. Audiograph.





Approved by *L. Beaman*

Frequency - Cycles per Second

Transmission Loss - Decibels

flat sheet to that of the arc of a circle of any desired radius. It is supported around all of its edges, but no additional bracing has been added to it.

In measuring the transmission loss through these panels a sound field of constant pressure is applied to one side of the panel, and the sound pressure measured on the other side of the panel is plotted directly as a function of frequency. Inasmuch as the input pressure is held constant, the output pressure is directly a measure of the transmission loss through the panel.

On page 187 is shown a curve of the transmission loss for the Douglas panel. Also plotted on this curve are data taken by Johns-Manville on this same panel using the two-room method described previously. Their data were taken using a warble tone source, and, therefore, their points are plotted as lines representing a frequency band. The agreement of the two sets of measurements is surprisingly good. This panel shows only one main resonance, at 140 cycles per second, at which frequency the transmission loss is only four decibels. At frequencies considerably higher than this resonance, the transmission loss becomes twenty-five to thirty decibels. It is clearly seen that the continuous frequency method of measurement is advantageous because the J. M. tests completely failed to indicate the resonant frequency.

The Consolidated panel has almost twice the area of the Douglas panel, and has longerons every six inches in one direction, and ribs every fourteen inches in the other direction. The result of this construction is to break up the dural skin into a number of small areas separated by rows of rivets fastening the skin to the other structure. Each of these small areas tend to show an individual resonant frequency, dependent upon its size and upon the tension of the skin. If the panel is excited by a sound field on one side, and the amplitude of vibration of the various areas of the panel is gauged, it is easy to locate certain areas which resonate at specific frequencies. The entire center of the panel is resonant at about eighty-seven cycles per second. The areas just to one side of the center resonate at 170 cycles per second, while those just to the other side of the center resonate at 240 cycles per second. The smaller areas around the edge of the panel show still higher frequency resonances. Page 189 shows a curve of transmission loss for this Consolidated panel, and shows the three lowest frequency resonances which have just been described. Again, the loss at the lowest frequency resonance is only about four decibels.

Tests are still being made on the special experimental panel, and no curves are given at this time. If the dural sheet is left flat, and supported only around its edges, its lowest resonance is too low in frequency to be measured with

available apparatus, but is evidently about five or ten cycles per second. With the panel in this flat shape, the transmission loss is negligibly small at resonance. Above this lowest resonance, the transmission loss increases almost uniformly at the rate of six decibels per octave. This is typical of a simple resonant system operating mass-controlled above its resonant frequency, for in such a case the mass reactance increases directly proportional to frequency. If the simple panel is bent into the arc of a circle of forty-eight inches radius, the lowest resonant frequency is raised to seventy cycles per second, and many additional resonances are introduced, so that the performance of the panel is greatly complicated.

One manufacturer (Douglas) has recommended that thin sheet mica be cemented to the inside of the dural skin of the fuselage in order to damp its vibration and reduce the transmission of sound through the panel. In order to test this procedure, the Consolidated panel was used, and sheet mica was fastened with U. S. Rubber cement to several areas of the skin. The mica used consisted of mica flakes, held together with some resinous material. Its thickness was .015 inches, and its weight was 0.17 pounds per square foot. As described previously, certain regions of this panel had been located which had a very definite resonance at 170 cycles per second. It was to these areas that the mica was first cemented, making no changes to the remainder of the panel. It was found that with the mica in place upon these regions, the transmission loss was not affected except for frequencies near this 170 cycle resonance. At this peak, the transmission loss was increased at least six decibels as shown on page 191. Following this test, similar sheets of mica were added to other portions of the panel, but in no case were the results so beneficial. The general conclusion may be drawn that the addition of mica is useful in increasing transmission loss for the panel if the mica is applied to areas of the skin which vibrate at their resonance in the manner of a membrane with clamped edges. If the region of the panel to which the mica is applied vibrates as a whole, so that the skin does not bend appreciably as it vibrates, then the effect of the mica is only to shift slightly the resonant frequency. Mica is useful only insofar as it may damp the actual bending of the dural skin. It was observed that over a period of some two weeks the increase in transmission loss due to the mica became slightly less. This effect might be ascribed to a drying out of the cement used to hold the mica in place, and leads to the belief that probably the material used to hold the mica in place is very important.

At the present time, intensive measurements on various materials used in the acoustic treatment of airplanes are just getting underway. Preliminary curves on a very few

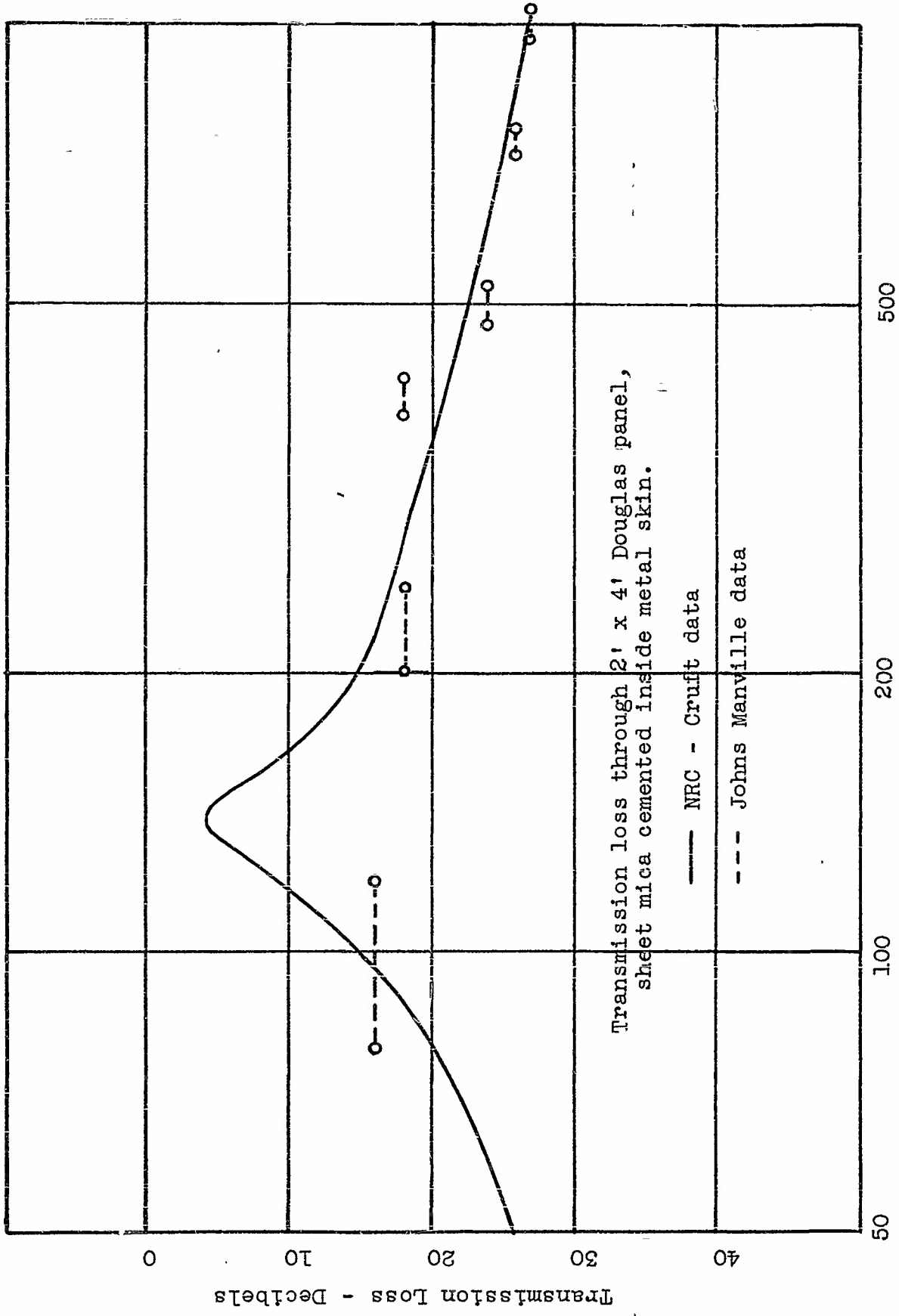

Approved by *H. Reynolds*

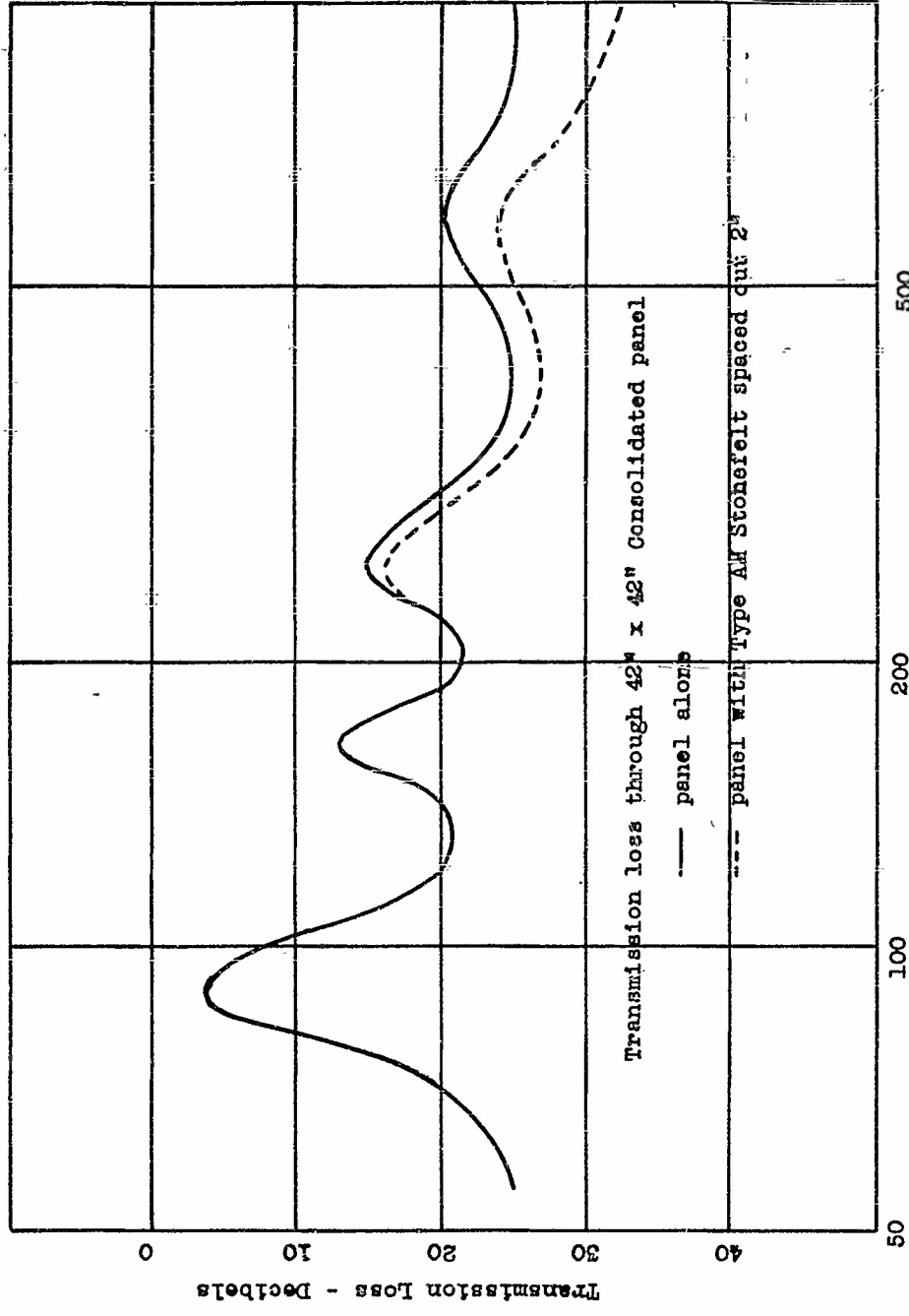

Approved by *L. B. Burch*

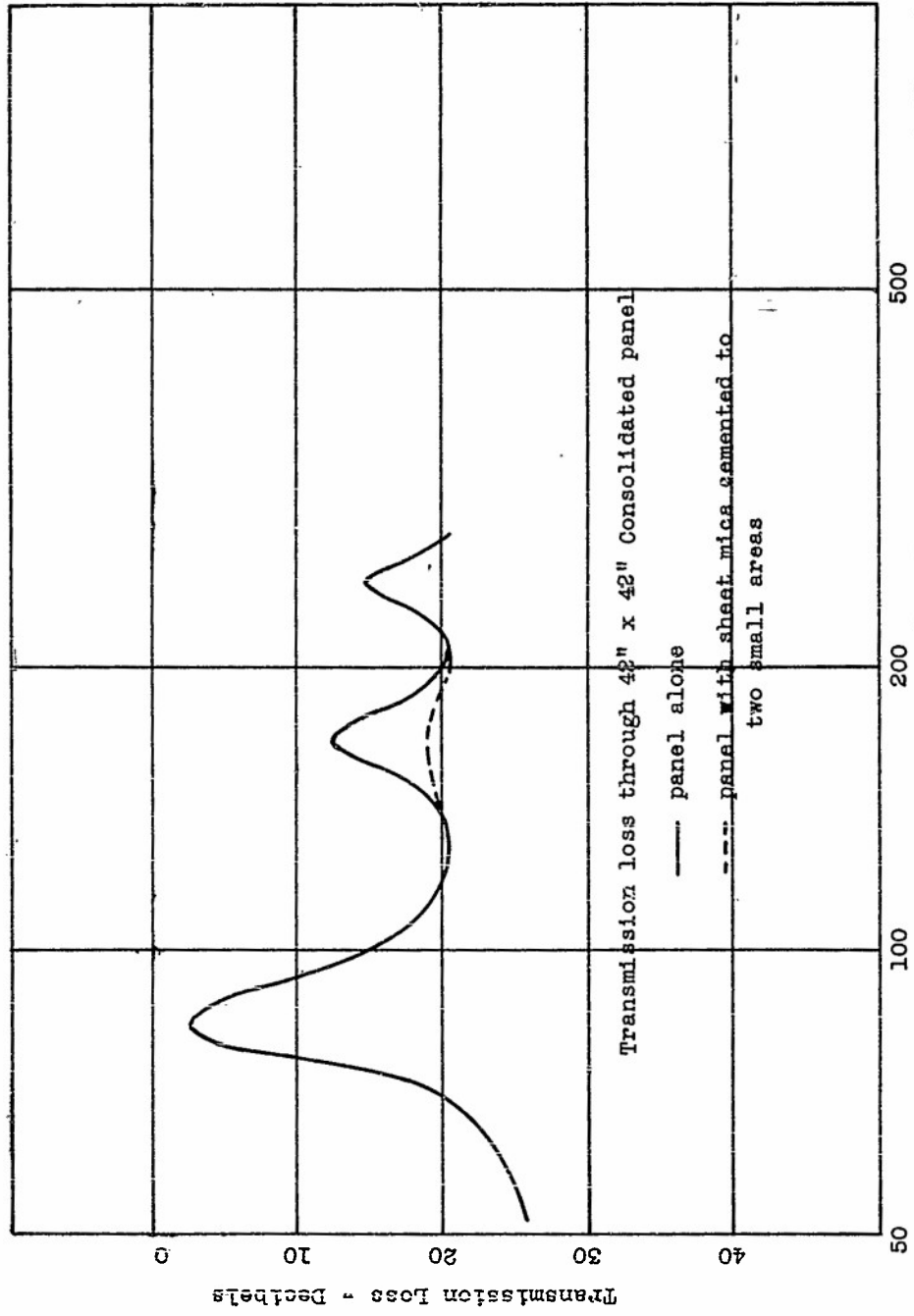

Approved by *L. Beaman*

Frequency - Cycles per Second

Transmission Loss - Decibels

materials are shown on page 195. It is hoped that in the near future tests may be made on a number of materials, placed next to the skin of the panel and spaced out a few inches from it. Measurements will be carried out on some of the more complicated constructions consisting of several materials, as well as on the simple structures of one material only. It is also intended to carry investigations further on the experimental panel, adding various bracing ribs to it in the manner of typical construction, and determining what effects each addition introduces.

In regard to the quieting of the interior of an airplane it would seem that a most fruitful field of endeavor would be that of finding some way to damp the low frequency resonances of the panels. These resonances, with their accompanying small transmission losses, occur in the range of frequencies in which propeller and engine noises are most predominant, so that very low attenuation is provided for this noise. If some way could be found of nullifying the effect of these low frequency resonances, very desirable results should be obtained. This aspect of the problem is being pursued.

d. Theoretical Treatment of the Sound Level Inside an Acoustically Treated Cabin.

The equivalent circuit for a section of fuselage with a thickness λ of absorbing material mounted a distance d from the outer skin can, to a first approximation, be drawn as follows:

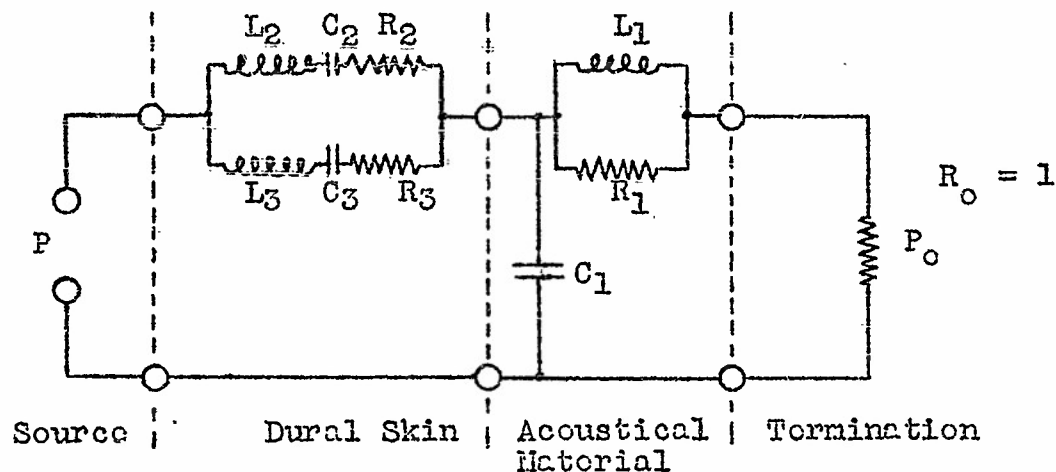

The transmission loss for such a structure is defined as

$$T.L. = 20 \log (p/p_0).$$

The assumption that the terminating impedance R_0 is unity is

reasonable as was shown on page 181. Actually, in the case of an airplane cabin, standing waves will be set up and the air load resistance on the inner wall will be different from one pc unit. Any exact evaluation of this input impedance to the room would be far too complicated for calculation.

Let us assume an enclosure with uniform walls of transmissivity τ and absorption coefficient α for the inner faces placed in a uniform sound field. τ is defined as the fraction of the sound energy incident on the external surface of the wall which gets through to the interior of the cabin. Then if we further assume the sound within the enclosure to be diffuse, the sound energy density, I_1 , inside the enclosure is well known to be related to the sound energy density, I_0 , outside the cabin by the relation

$$\frac{I_1}{I_0} = \left(\frac{\tau}{\tau + \alpha} \right)$$

An alternative form of expression is that the Sound Level Reduction inside the cavity due to the walls is

$$\text{Sound Level Reduction in decibels} = 10 \log \left(\frac{\tau + \alpha}{\tau} \right)$$

On page 197 is a plot of this equation, giving contours of constant Sound Level Reduction as a function of absorption coefficient and either transmissivity or transmission loss. The plots shows several points immediately. With zero absorption, the sound level within is just the same as the sound level without, regardless of the transmission loss. With zero transmission loss, even 100% absorption can give only a 3 decibel reduction in sound level. Furthermore, it is the fractional decrease in transmissivity or fractional increase in absorption coefficient which counts; changing the absorption coefficient from 0.5 to 1.0 brings about the same increase in sound level reduction as changing it from 0.25 to 0.5, or .05 to .1.

This sound level reduction factor suggests itself as a single figure of merit which, as a function of frequency, could be used to evaluate on a relative scale various types of fuselage treatment. As such it can be useful, but it must be used with great caution, because of the assumptions and limitations in its derivation. In the first place, we do not have diffuse sound either inside or outside of an airplane fuselage. In the interior standing waves are certainly excited to some degree, and propeller noise, when the propeller clearance is small, undoubtedly acts as a localized source near the sides of the fuselage. Until experimental data can tell us more about the pressure distribution inside the cabin for a very narrow band of frequencies, that is, to what extent individual normal modes contribute to standing waves in the cabin; and more about

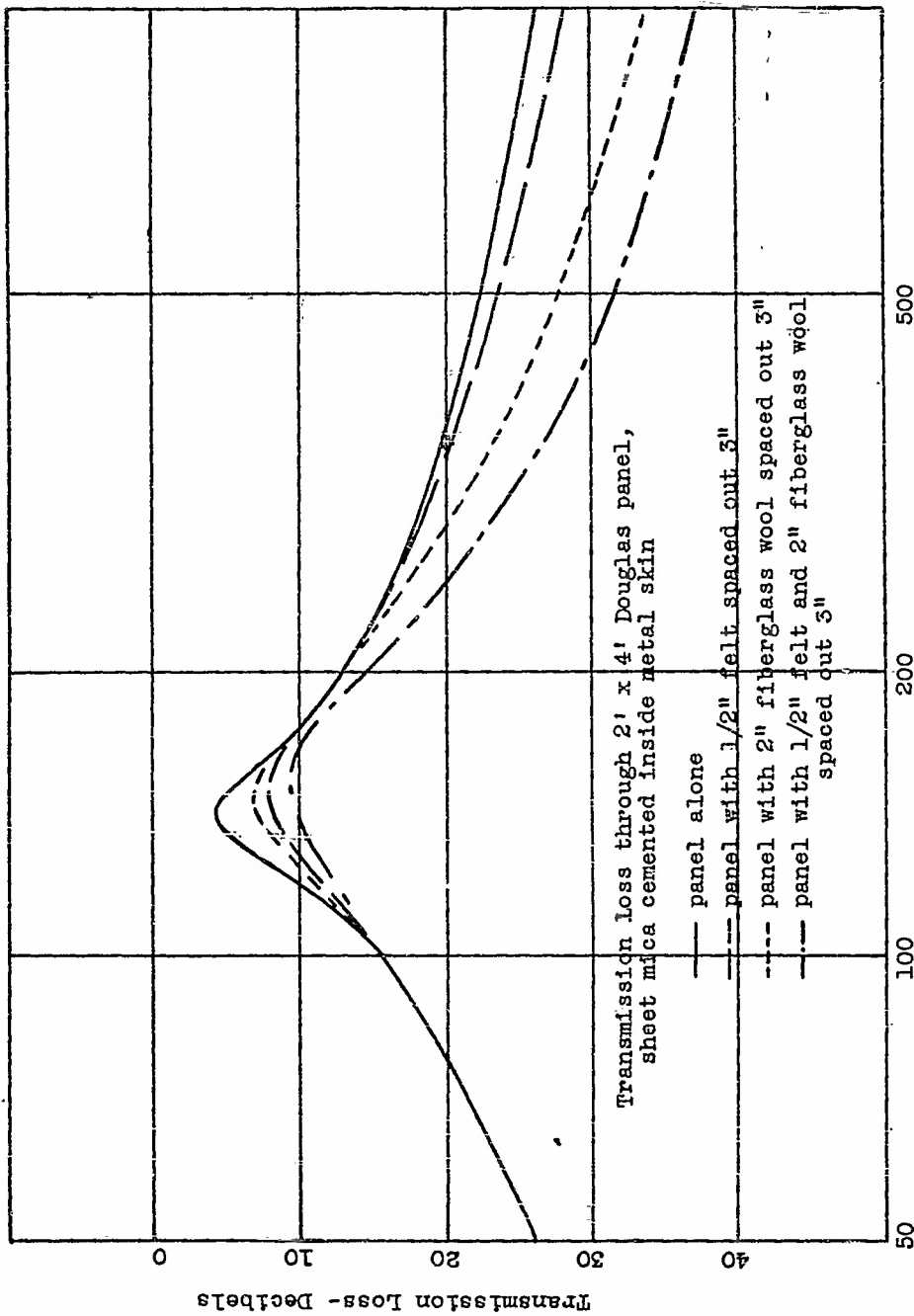

Approved by L. B. Berman

the pressure distribution outside the cabin, it is not safe to or advisable to combine α and τ into a single figure of merit. It seems far better to consider the sound inside the cabin as largely made up of travelling waves, for the most part entering the cabin from regions near the motors or propellers and leaving it from other parts of the fuselage. From this point of view, in computing total noise reduction, τ is the important factor in areas near the propellers, and α is the important factor in areas "far" removed from the sources of sound. Just what relative weights should be given to the two factors, then, can not be stated until more is known about the sound distribution in airplane cabins.

WINDOW TRANSMISSION

a. Introduction

Because windows are numerous in any type of aircraft, it is important that their acoustical transmission characteristics be investigated as part of a research program aimed toward reducing noise levels. Many papers on the attenuation of sound by glass have been published but the data presented have resulted from considerations of large windows such as are used either in broadcasting studios or in railway pullman cars. It has generally been assumed that the fundamental resonance frequency of such windows is below the audible range and hence need not be considered. A very different situation exists when the windows are of the order of 12" square. In this case the fundamental resonance frequency is usually between 50 and 200 cycles and the largest amount of sound transmission occurs at this frequency. Also, measurements show that the important noise components of both the motor and the propeller lie in this frequency range. Hence it is of particular interest to know just what thickness and construction of window must be used in order that one may achieve at least as good sound reduction as is obtained from the surrounding section of fuselage. In this investigation the transmission of windows ranging in size from eight to eighteen inches square (or rectangular) made of different materials and of different thickness is considered. This investigation does not include in great detail the transmitting characteristics of window and fuselage combined, but rather those of the window alone, which fact demands that the edges of the window be held rigidly. To accomplish this, the window is set in a heavy frame which is rigidly supported in a brick wall. The sound transmitted comes through the window alone, the brick wall and the frame being relatively immovable.

Early experimenters mounted their windows in a wall separating two rooms. A source of sound and a microphone were located in one room and a second microphone for measuring transmitted sound located in the other room. The difference between the outputs of the two microphones was used as a measure of the transmission of the window. Difficulties were encountered in using this technique since the standing wave pattern set up in both rooms due to resonances introduced unknown factors of such importance that frequently neither the driving pressure nor the transmitted energy were determinable with even tolerable precision. Various devices and techniques such as rotating loud speakers, rotating microphones, and warble tones were employed to cut down these inaccuracies with varying degrees of success. To avoid these difficulties in our investigation, it was decided to build an apparatus which applies a uniform sound pressure to the primary side of the window and to conduct the sound radiated from the secondary side into a highly absorbing termination such that little or

no resonance effects exist to disturb the accuracy of the measurements. To this purpose the apparatus described below was evolved

b. Experimental Apparatus

A cross-sectional sketch of the apparatus is shown on page 203, and photographs are shown on pages 205 to 211. The window (single or double) is held in an aluminum frame which in turn is mounted in a concrete-filled steel frame rigidly fastened to the brick wall. The sound is generated by four loudspeakers which are mounted about 1/2 inch from the first pane. This arrangement serves to produce a uniform sound pressure over the entire pane. The opposite side of the window opens into a cotton filled tube which serves to absorb almost completely the transmitted sound. A microphone is mounted on each side of the window to measure the magnitude of sound pressure on the two sides and the ratio of their outputs expressed in decibels is used as a measure of the transmission loss of the structure under test.

Details of the steel frame in which the windows are held are seen in Fig. 14. The frame is constructed of 5/8" steel plates in the form of a rectangular "doughnut" four inches thick. The space inside the steel plates is filled with concrete and the entire unit cemented into the 12" brick wall as seen in Figs. 14 and 15. The aluminum frame is shown in Fig. 17 and slips inside this steel doughnut. It is so constructed that it will support either one pane of window material or several panes separated by from 1" to 5". The four loud speaker units driving the window are shown in Fig. 16. These units fit inside the aluminum frame and are separated from the glass by a distance of approximately 1/2". A crystal microphone is calibrated relative to a microphone placed in the terminating tube on the opposite side of the window. If the microphone outputs are expressed in decibels their difference is a measure of the attenuation of the window. We shall express this difference as a Transmission Loss defined by the equation

$$T. L. = 20 \log_{10} p/p_0$$

where p is the sound pressure on the primary side and p_0 is the sound pressure on the secondary side of the window. The eight foot terminating tube is shown in Fig. 18. It is subdivided into four channels such that cross resonances do not take place at frequencies below about 800 cycles. This tube is filled with loosely packed cotton and acts as a highly absorbing termination of known impedance. The electrical apparatus associated with the measurement can be seen in Fig. 19. The loud speakers are driven by a beat frequency oscillator whose output is continuously variable over the

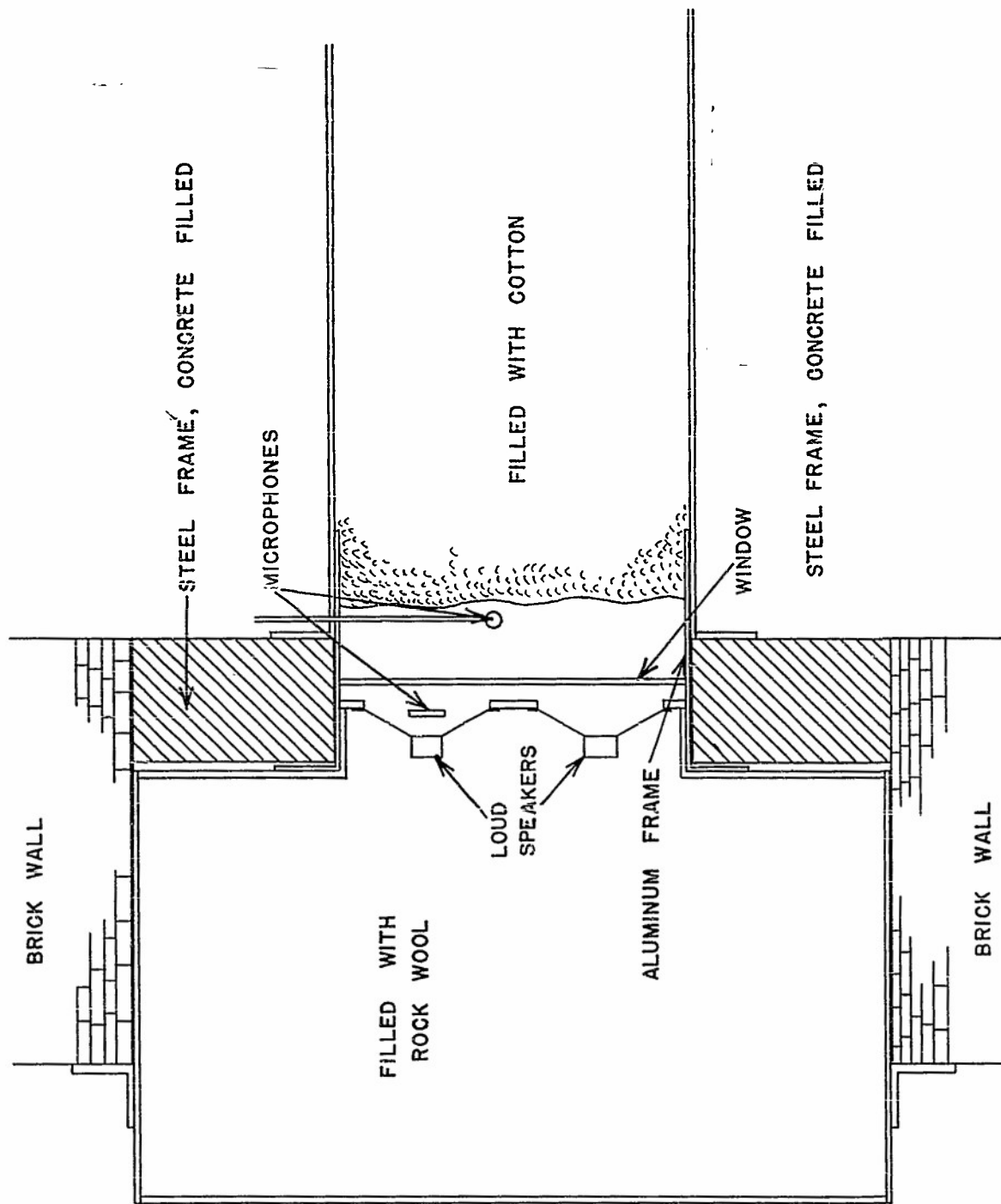

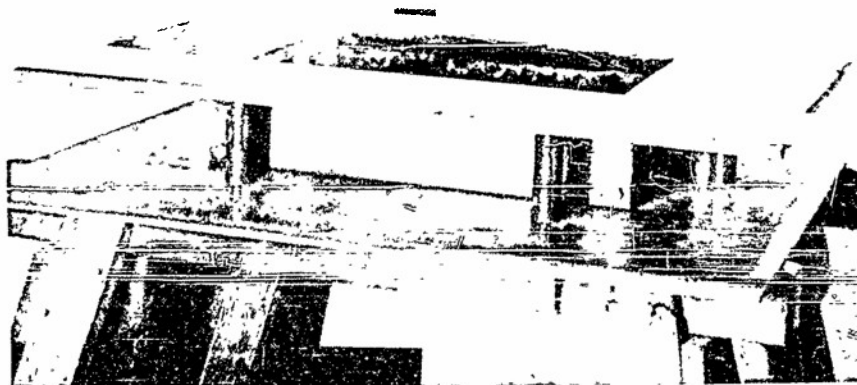

Fig. 14. Supporting frame.

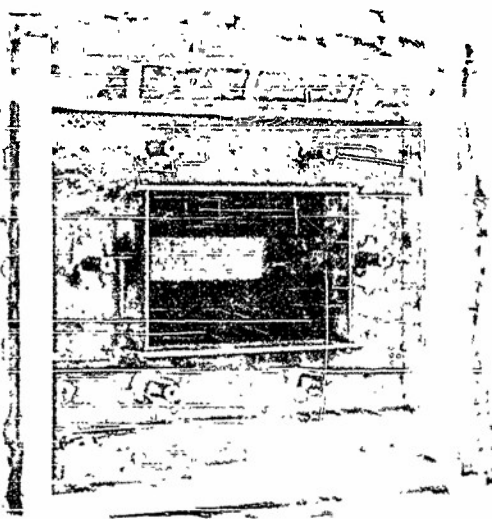

Fig. 15. Frame mounted in wall.

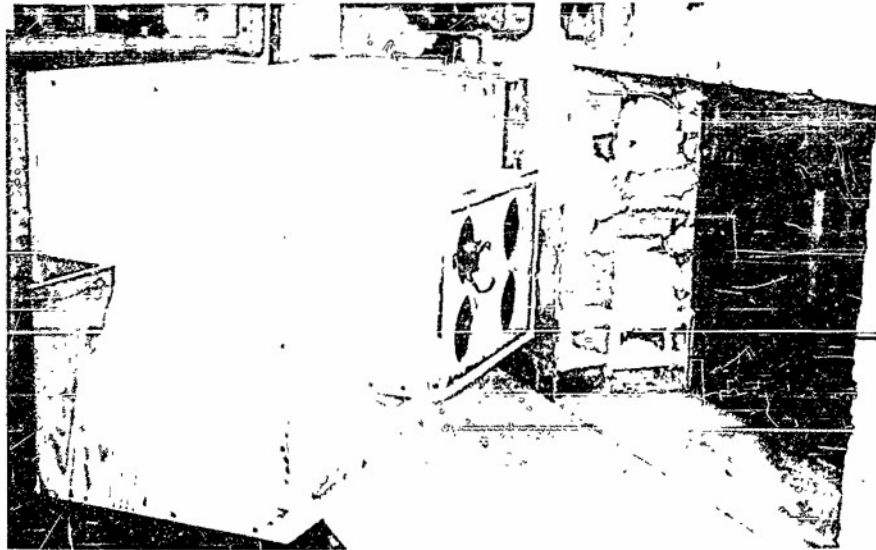

Fig. 16. Loudspeaker driving unit.



Fig. 17. Aluminum frame for holding windows.

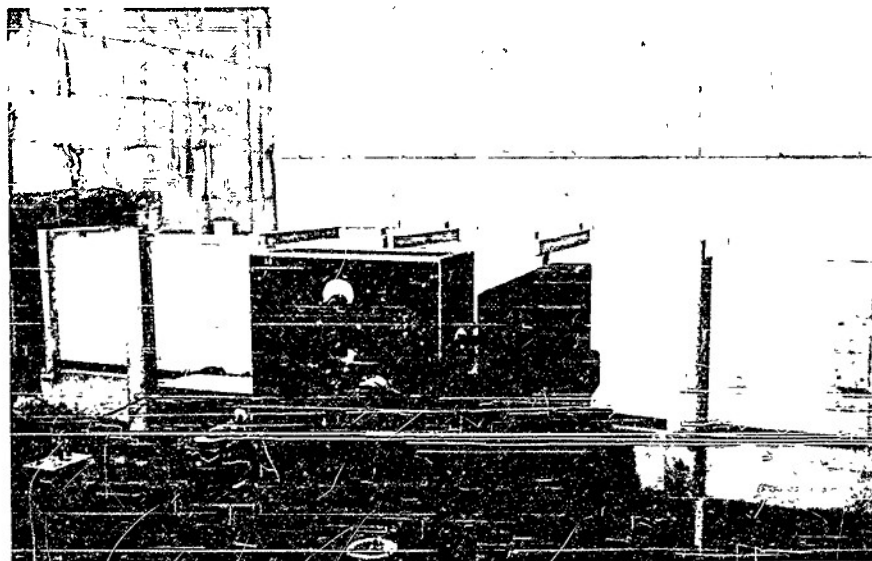

Fig. 18. Eight foot cotton-filled terminating tube.

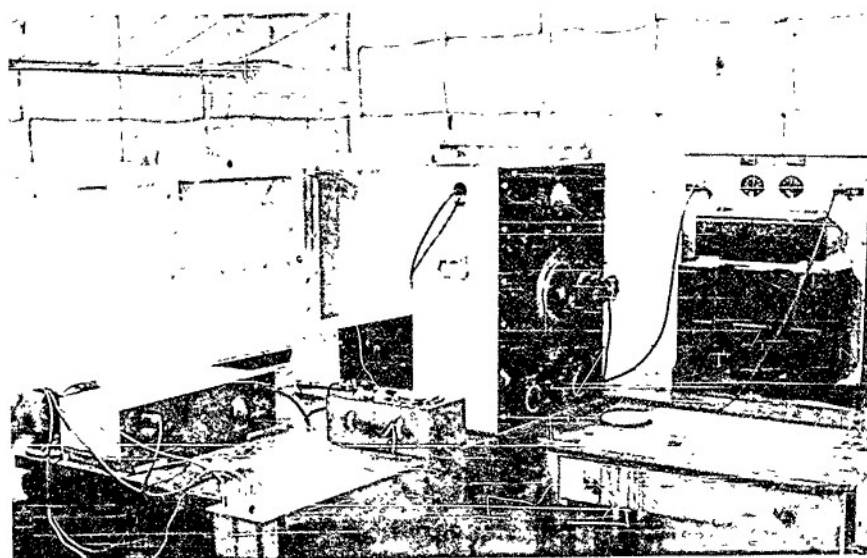

Fig. 19. Electrical apparatus.

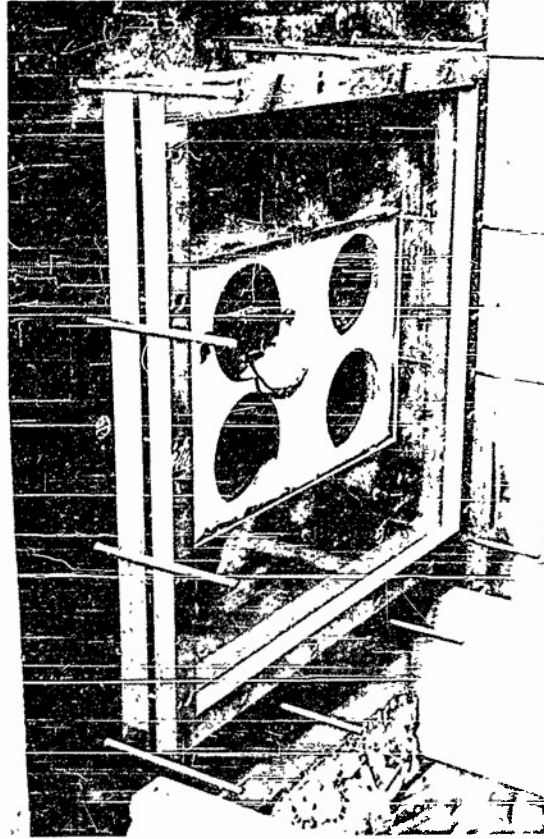

Fig. 20. Eighteen inch window mounted in place.

frequency range from 20 to several thousand cycles by means of a motor attachment. Two techniques of measurement are possible. First, the pressure may be held constant on the primary side and an automatic recorder used to record the output of the second microphone as the oscillator sweeps through its frequency range. The recorded curve is thus a direct measure of the transmission of the window. Second, the curves may be taken point by point by setting the oscillator on a fixed frequency and comparing the outputs of the microphones directly, the difference between their readings being the transmission loss at the frequency. The first method was used during the preliminary measurements to locate sources of error, while the latter and more accurate method was used to obtain the data presented in this report.

c. Theory

The effectiveness of a given window installation in preventing the transmission of sound depends on the material from which the window is made, on the dimensions of the window, and on the manner in which the window is mounted. For a window with firmly clamped edges, for instance, the acoustic characteristics should be determined by the dimensions, the Young's modulus of the material, the Poisson ratio, and some quantity specifying the dissipation of energy required to deform the window. Though these properties should determine the transmission qualities of the window, it has long been considered impossible to derive from them an exact mathematical expression for the acoustic attenuation. In the past, many simplifying assumptions have been made and with these assumptions it has been possible to predict an approximate mathematical expression for the behavior of the window.

In this investigation it has been found that the acoustic properties of a window can conveniently be specified by giving element sizes in an electrical circuit to which, for the purpose of calculation, the window may be considered equivalent. The equivalent circuit for the window and measuring apparatus used in this work is

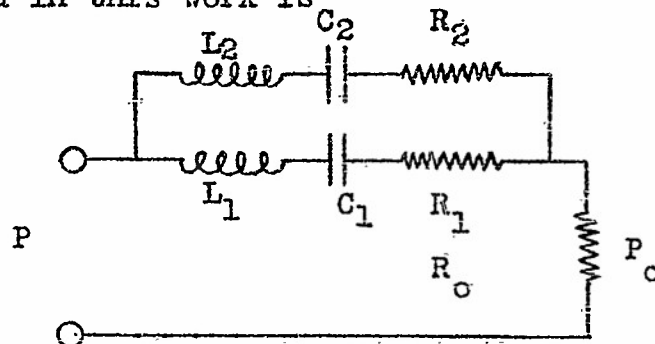

where p is the sound pressure applied to the window and p_o is the sound pressure transmitted by the window. Pressures are to be measured in dynes per square centimeter and acoustic particle velocities are to be measured in centimeters per second. R_o is the known specific acoustic impedance of the terminating tube. The window is equivalent to a group of series resonant circuits connected in parallel. These resonant circuits represent the various possible modes of mechanical vibration of the window, and as was expected, it has been found that that part of the circuit (R_1 , L_1 , and C_1) which corresponds to the gravest mode of vibration of the window is most important in determining the low frequency attenuation characteristics.

The data presented in this report are sufficiently accurate to permit calculation of the element sizes from the attenuation curves. Near the fundamental resonance frequency, the impedances of the elements corresponding to the higher modes are sufficiently high to be neglected. The elements corresponding to the fundamental resonance may be calculated from the formulas

$$(1) \quad R_1 = (10^{N/20} - 1)R_o$$

$$(2) \quad L_1 = \frac{10^{N/20}}{2\pi \Delta f} R_o$$

$$(3) \quad C_1 = \frac{1}{L_1 (2\pi f_1)^2}$$

where N is the number of decibels of attenuation at the resonance frequency, f_1 is the resonance frequency, R_o is the termination impedance, and Δf is the width of the resonance curve in cycles per second three decibels down from the resonance peak. Elements for the higher order resonances have not as yet been calculated.

One of the purposes of this investigation is to obtain data from which the acoustic properties of any window suitable for use in aircraft may be predicted. Since the acoustic properties depend on the dimensions, the material from which the window is made, and the mounting conditions, it is necessary to determine experimentally how the equivalent circuit elements depend on these things.

d. Measurements on Single Windows

A great many measurements have been made on 10" x 14" windows of various materials and thicknesses. In order to study the effect of clamping conditions measurements have been made on windows with edges bound in 1/16" thick rubber tape and firmly clamped and on many of the same windows

frequency range from 20 to several thousand cycles by means of a motor attachment. Two techniques of measurement are possible. First, the pressure may be held constant on the primary side and an automatic recorder used to record the output of the second microphone as the oscillator sweeps through its frequency range. The recorded curve is thus a direct measure of the transmission of the window. Second, the curves may be taken point by point by setting the oscillator on a fixed frequency and comparing the outputs of the microphones directly, the difference between their readings being the transmission loss at the frequency. The first method was used during the preliminary measurements to locate sources of error, while the latter and more accurate method was used to obtain the data presented in this report.

c. Theory

The effectiveness of a given window installation in preventing the transmission of sound depends on the material from which the window is made, on the dimensions of the window, and on the manner in which the window is mounted. For a window with firmly clamped edges, for instance, the acoustic characteristics should be determined by the dimensions, the Young's modulus of the material, the Poisson ratio, and some quantity specifying the dissipation of energy required to deform the window. Though these properties should determine the transmission qualities of the window, it has long been considered impossible to derive from them an exact mathematical expression for the acoustic attenuation. In the past, many simplifying assumptions have been made and with these assumptions it has been possible to predict an approximate mathematical expression for the behavior of the window.

In this investigation it has been found that the acoustic properties of a window can conveniently be specified by giving element sizes in an electrical circuit to which, for the purpose of calculation, the window may be considered equivalent. The equivalent circuit for the window and measuring apparatus used in this work is

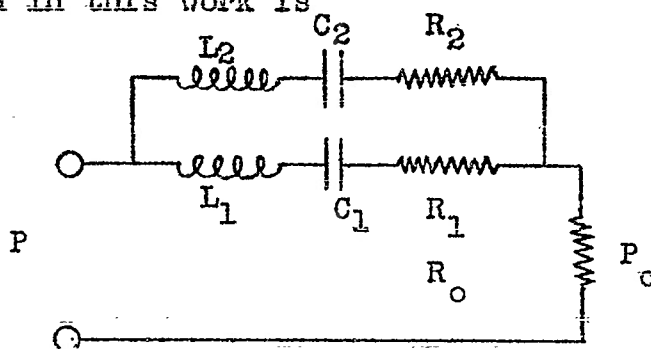

without rubber tape. Some of these curves are presented on the following pages. Experimental points have not been shown below the first resonance on most curves. This is for a reason which is explained in a later section of this paper and does not indicate that accurate measurements were not made at these frequencies.

Perhaps the most striking thing about the curves is the very small attenuation at the fundamental resonance peak. In terms of the elements in the equivalent circuit this means that the resistance R_1 is very small. In other words, there is very little dissipation of energy in the window.

The first sheet of curves, page 217, permits an easy comparison of the acoustic qualities of 0.069" Plexiglas and five-ply "Safetee Glass 2-1". The dotted straight lines at the right hand side of the page are calculated on the assumption that the window behaves as an inductance $L = \frac{1}{\sigma}$, where σ is the weight per unit area of the window in gm/cm.² Previous investigators have made this assumption in calculating the attenuation produced by windows at frequencies well above the fundamental resonance frequency. For the sake of brevity, curves calculated on this basis will be called sigma-law curves. It is seen that at frequencies near 1000 cycles the measured curve for the thin Plexiglas window fits the sigma-law curve closely. The curve for the heavier window does not agree so well with the sigma-law predictions at these frequencies but it may well be that the agreement would be better at higher frequencies. All the measurements which have been made to date indicate that thin windows follow the predictions of the sigma-law very well at high frequencies while thick windows show appreciable departures. The superior attenuation given by the Safetee Glass is largely attributable to its greater weight. (The Safetee Glass window weighed 960 grams as compared to 188 grams for the Plexiglas.) Windows of the same weight but of different materials do not show very remarkable differences in acoustic properties. To illustrate this point, the curves on page 219 are shown. One of the curves is for window glass and the other is for a Plexiglas window of approximately the same weight. The weights per unit area, σ , are given in the legends of all curves. Plexiglas shows slightly more damping at the second resonance peak but aside from this the curves are quite similar.

To illustrate the improvement obtained by using a greater weight of material, curves for three thicknesses of Plexiglas are shown on page 221. These curves show that the thicker windows give somewhat better attenuation at the fundamental resonance frequency, that the resonance frequency is higher for heavier windows, and that the heavier windows give somewhat better "average" attenuation.

On page 223, a curve for an 18" x 18" Plexiglas window is shown. This curve is similar to the one obtained for the 10" x 14" window of the same material and thickness except that the resonance frequencies are much lower.

The curve on page 225 is for a Plexiglas window mounted in an 18" x 18" panel of 17ST Dural. This window was supplied by the Consolidated Aircraft Corporation. The legend on the blue-print which was sent with it reads "ASSEMBLY-FUSE-GUNNER'S WINDOW --- BULK'D 6 to B.F. 6.2". The attenuation characteristics are just what would have been expected from the previous measurements. The only important effect of the Dural mounting is to lower the resonance frequency somewhat by adding compliance. In terms of the equivalent circuit this means that L_1 and R_1 have values very near those which correspond to a clamped window made of Plexiglas of the same thickness as the window which was mounted in Dural but C_1 has a somewhat larger value.

The curve on page 227 is for an 18" x 18" x .04" 17ST Dural panel. It is different from the preceding ones in that it shows much less dissipation. The result is that even the high order resonances give good transmission of sound and that the anti-resonance between the first two resonances is very pronounced.

Reference to the equivalent circuit for the window and termination given on page 213 will show that the quantity which has been called Transmission Loss is not a function of the window alone but depends also on the value of R_0 . Furthermore, the effectiveness of a given window in producing sound insulation will depend on the acoustic properties of the surrounding medium as well as on those of the window. On the other hand, the constants R_1 , L_1 , C_1 , etc. have the desirable property of being dependent only on the window. When these constants and the impedance of the medium into which the window works are known, the problem of calculating the attenuation of sound due to the window is reduced to that of solving the equation for the simple equivalent circuit previously given.

Calculations show that the low frequency response of windows is accounted for with rather good accuracy if the equivalent circuit is assumed to consist only of R_1 , L_1 , and C_1 , the constants which determine the fundamental resonance. This makes it possible to specify the acoustic properties of the window over the range of frequencies which is of interest for sound insulation in aircraft by giving only the values of these three constants. In Table V, page 230, constants are given for various materials which have been tested. This table also gives the weight per unit area of the material, the fundamental and higher order

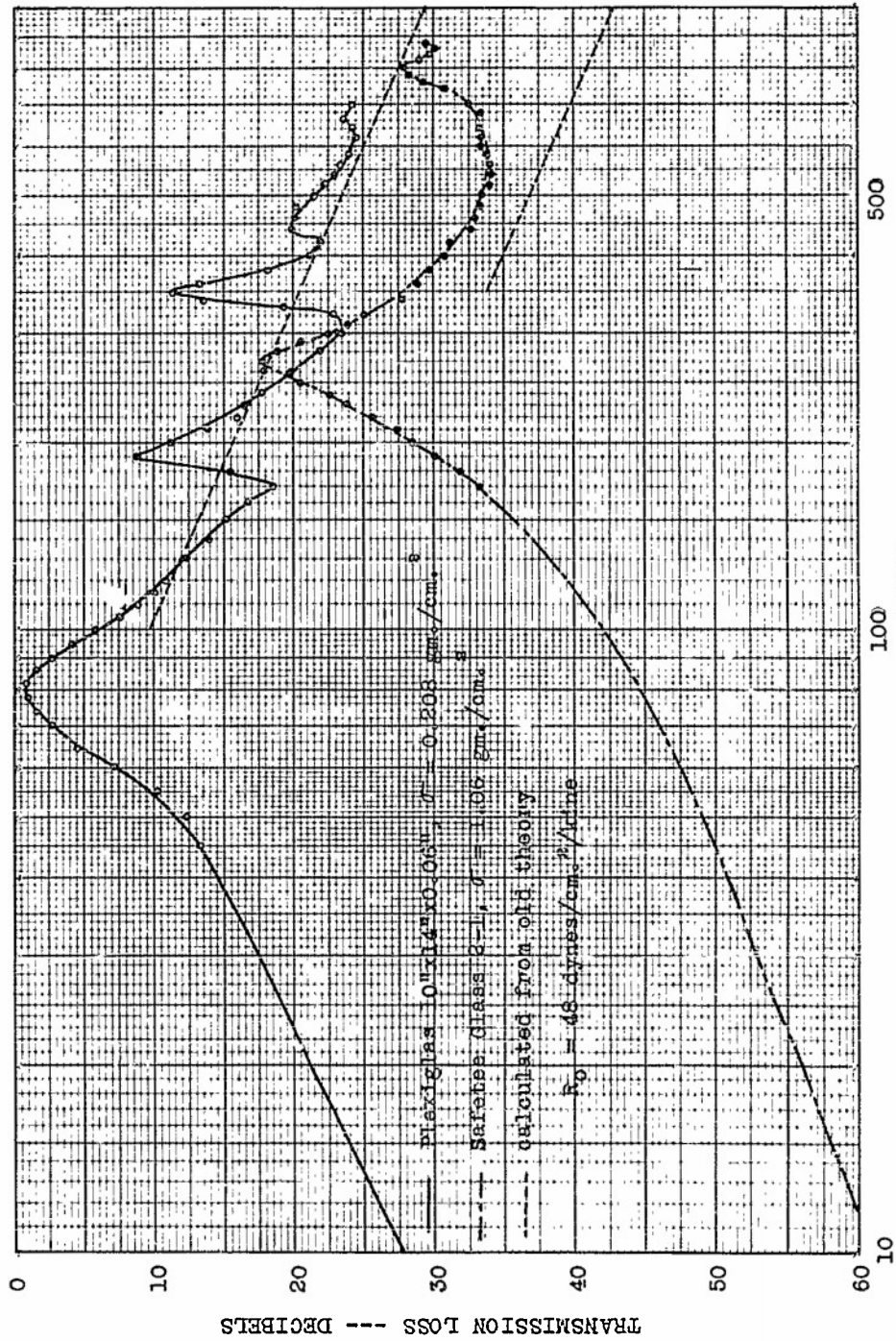

FREQUENCY --- CYCLES

Approved *LFB*

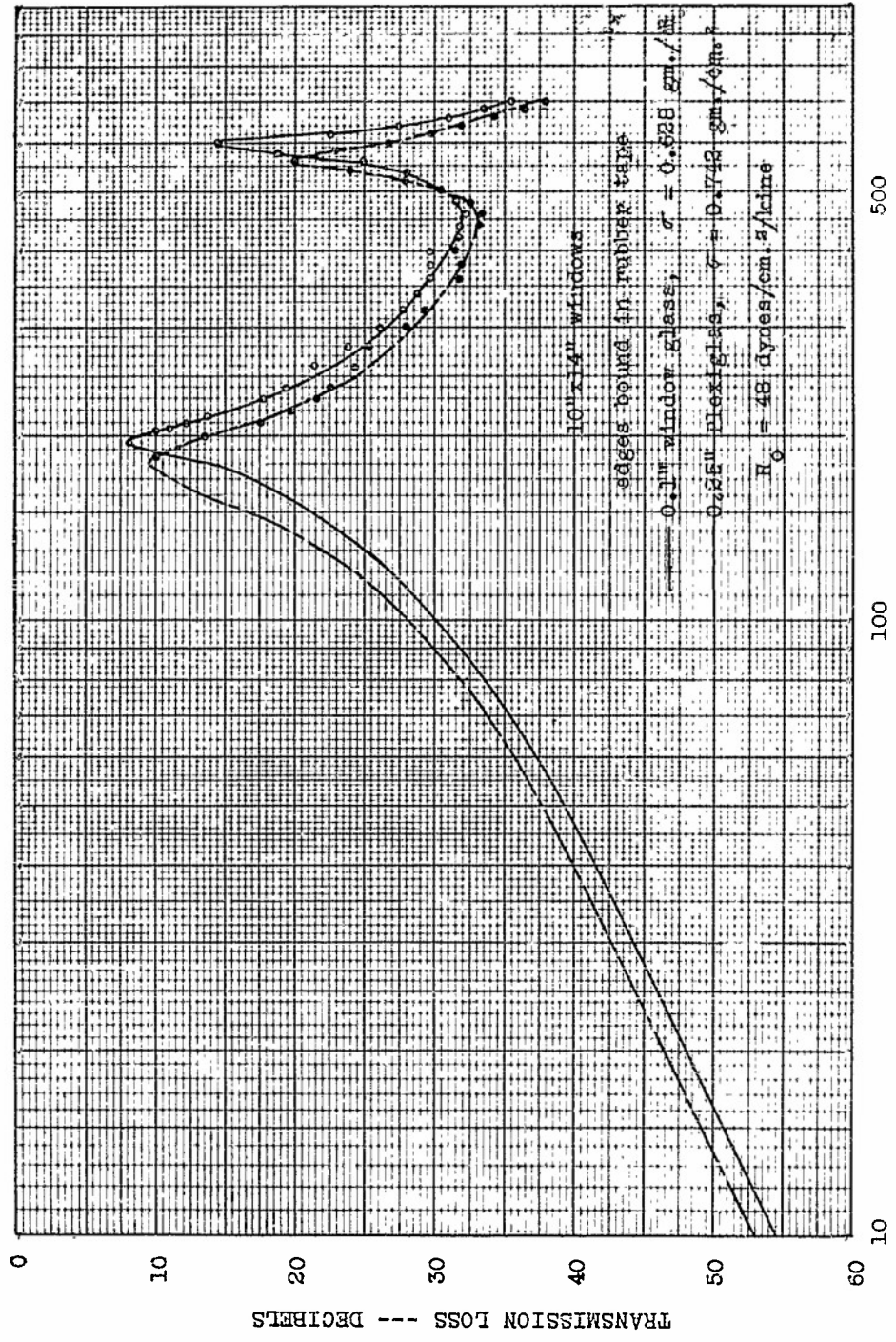

Approved *LFB*

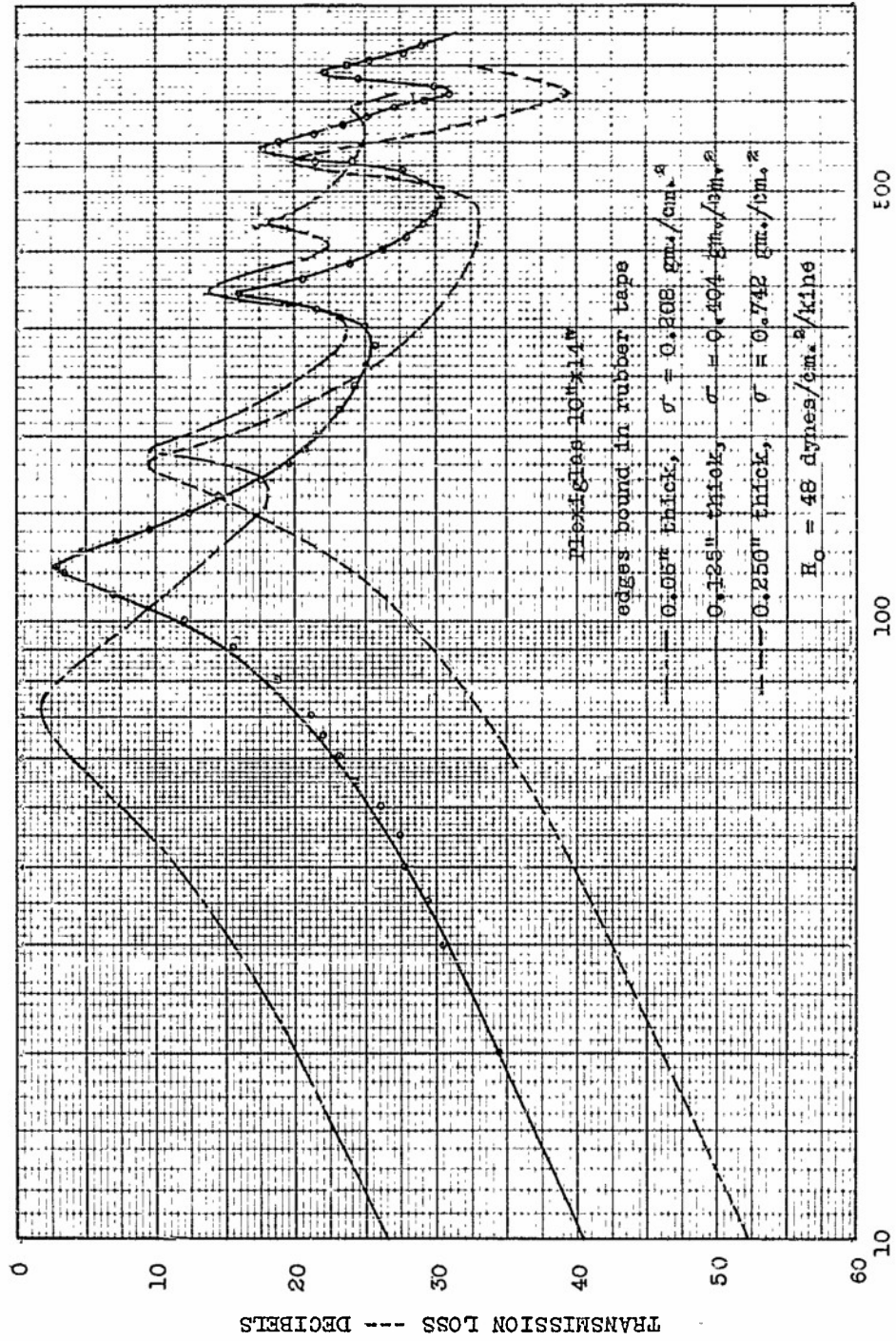

FREQUENCY --- CYCLES

Approved. *RFB*

62
100

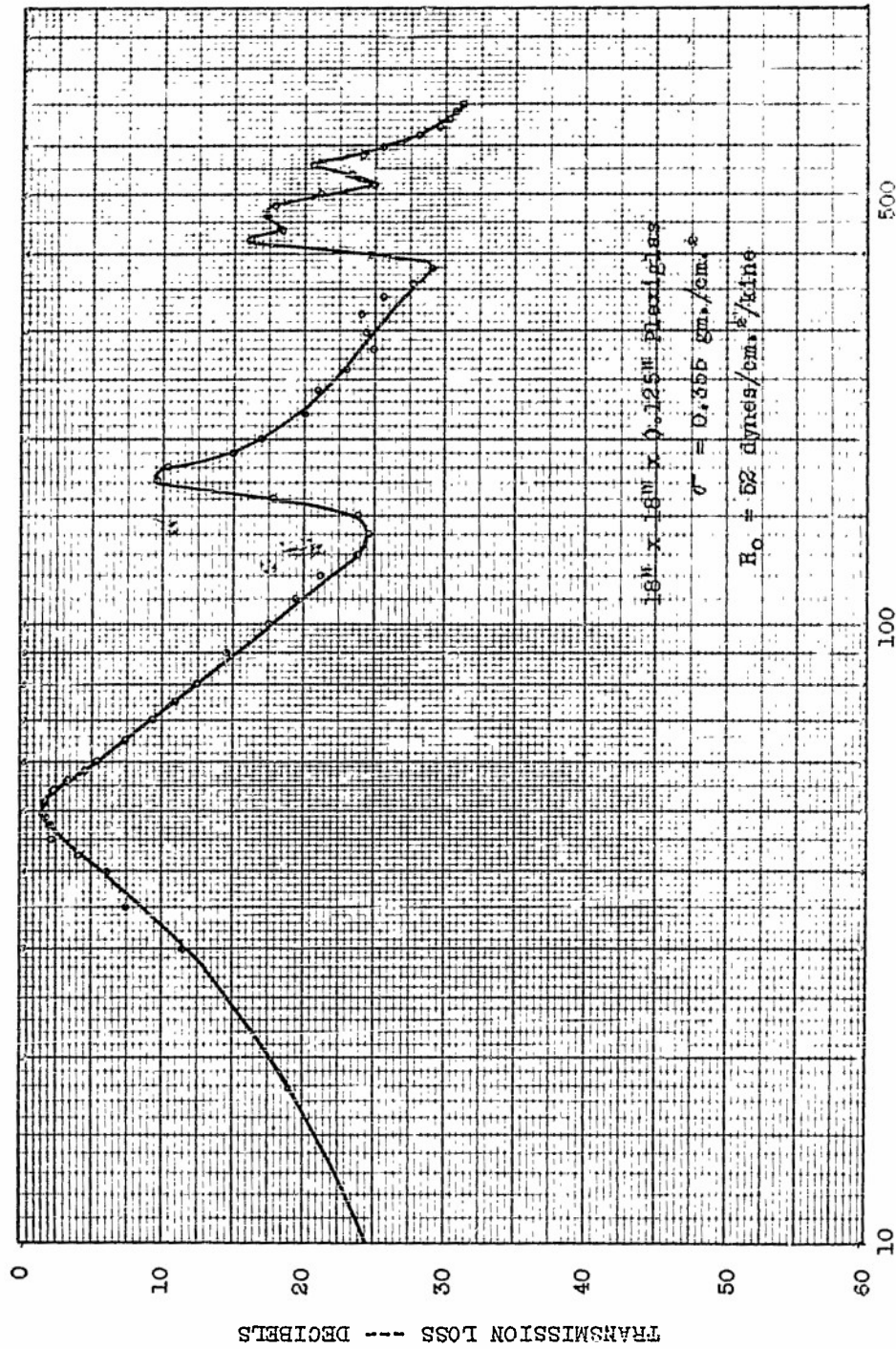

FREQUENCY --- CYCLES

Approved *LTD*

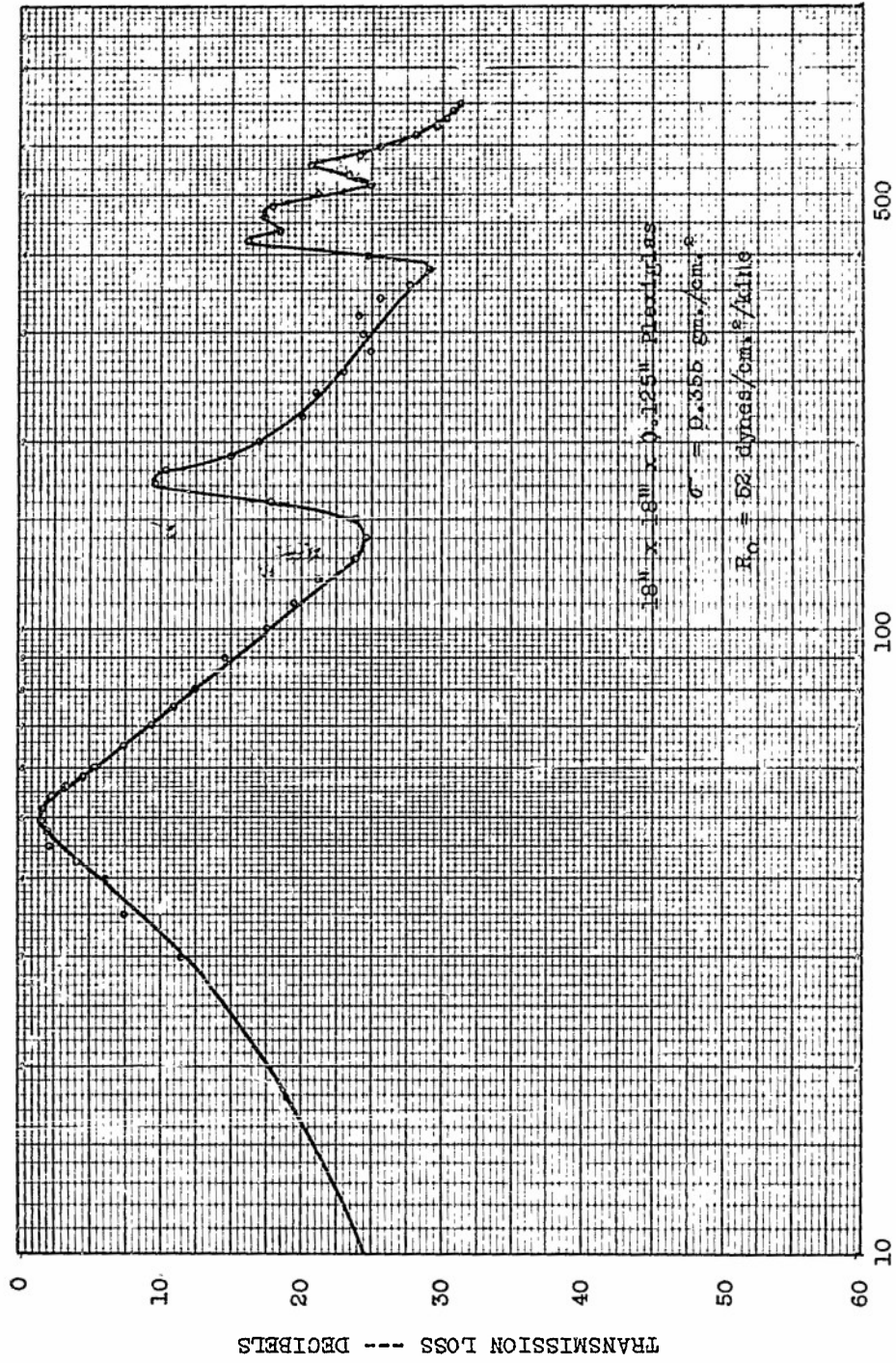

Approved *LJD*

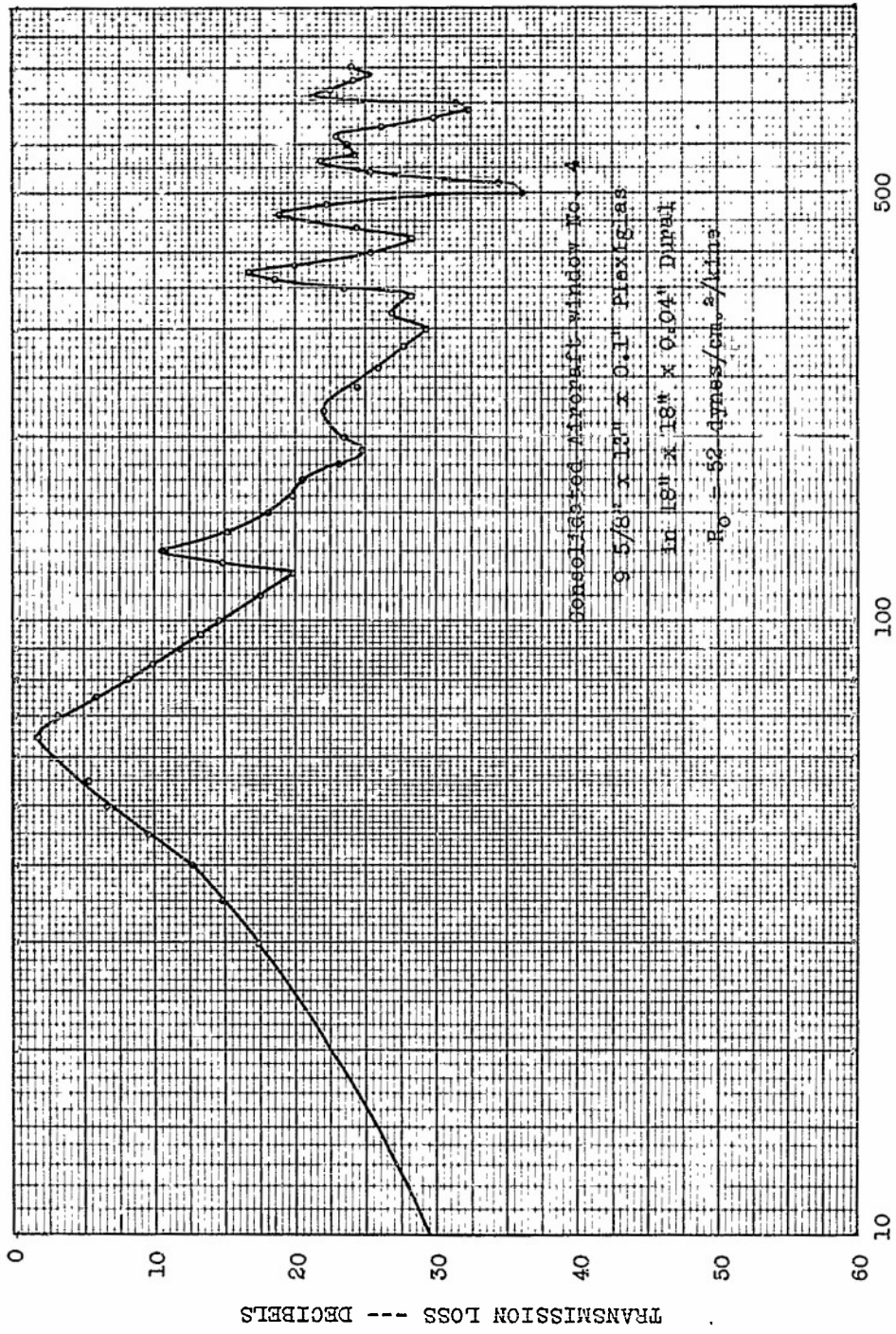

Approved 278

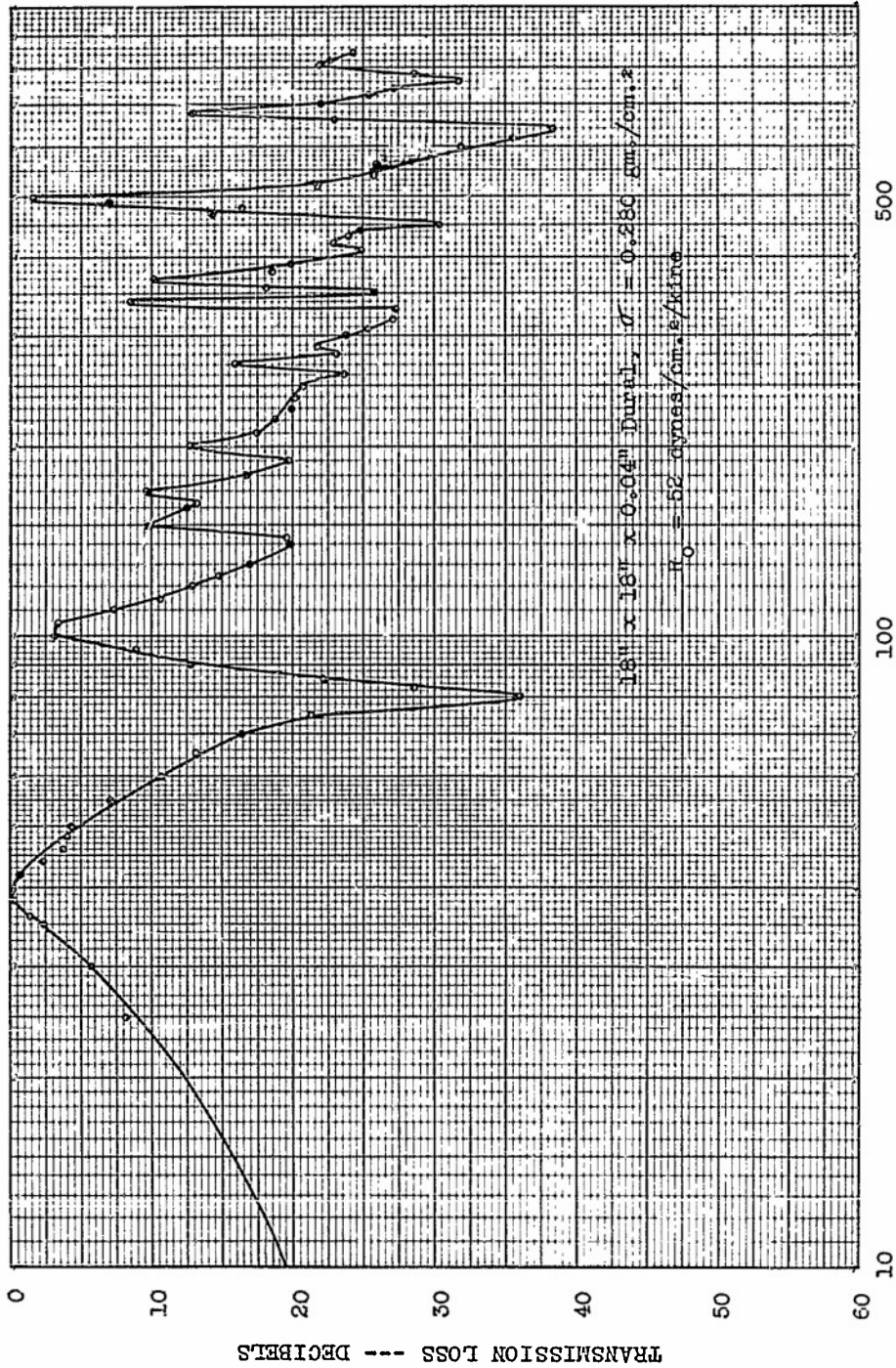

FREQUENCY --- CYCLES

Approved *XAS*

resonance frequencies, the attenuation at the fundamental resonance, and the resistance R_0 of the termination. All values of resistance are given in dynes per square centimeter per kine and the values of L and C are in corresponding units. This is to say, all impedances calculated from the element sizes given have the units of pressures (in dynes per cm.²) divided by particle velocity in (cm. per second.)

Investigation of the data presented in Table V shows that the inductance L_1 is roughly equal to 1.5 times the surface density σ and is independent of the material and of the lateral dimensions of the window. This is not inconsistent with a sigma-law variation at high frequencies, since, as the frequency increases, L_2 , L_3 , etc. tend to make the attenuation less than would be obtained from L_1 alone.

The frequency of the fundamental resonance of a window of given material and lateral dimensions is roughly proportional to the thickness and therefore to the weight per unit area of the window. This means that C_1 is roughly proportional to the inverse cube of σ . The equivalent capacitance of a window of given lateral dimensions depends somewhat on the material from which the window is made but the materials tested so far have, for a given surface density, equivalent capacitances which are in the same order of magnitude.

The resistance R_1 increases very rapidly with increase of σ , approximately as the square of σ . For a given surface density, Lucite and Plexiglas show roughly the same value of R_1 while window glass shows a lower value and Safetec Glass shows a higher value.

Only a few tests have been made toward determining the dependence of the equivalent constants on the lateral dimensions of the window but those tests which have been made indicate that the frequency of fundamental resonance is approximately inversely proportional to the area of the window and that the inductance is independent of the lateral dimensions. This means that the capacitance must be approximately proportional to the square of the area. It is not to be expected that these simple relations would hold for rectangular windows which depart radically from being square but such windows are not in common use. The measurements which have been made seem to indicate that the resistance is independent of the lateral dimensions of the window. More tests must be made, however, before this can definitely be confirmed.

The curves on pages 231, 233, 235 and 237 show the variation of the constants of 10" x 14" Plexiglas windows with surface density. These curves also show the effect of binding the edges of the windows in 1/16" tape.

Table 5,

WINDOWS AT LOW FREQUENCIES

Material	Thickness in.	d ₁ cm.	Lateral dim.	Binding R ₁ cm.	R ₁ dynes cm. ² /line	L ₁ cm.	C ₁ cm. ³ dynes 10 ⁻⁶ x	f ₁ c.p.s.	f ₂ c.p.s.	N db.	R ₀ dynes cm. ² /line
Plexiglas	0.06	0.208	A	D	6	0.30	13	80	190	1.0	48
Plexiglas	0.125	0.371	A	D	6	0.59	2.9	122	340	1.0	48
Plexiglas	0.25	0.758	A	D	130	1.05	0.52	215	650	11.5	48
Plexiglas	0.5	1.67	A	D	460			365	800	20.5	48
Plexiglas	0.06	0.208	A	C	9	0.34	12	70	190	1.5	48
Plexiglas	0.125	0.404	A	C	18	0.64	2.7	122	240	3.0	48
Plexiglas	0.25	0.742	A	C	98	0.97	0.82	178	560	9.6	48
Plexiglas	0.5	1.67	A	C	490	2.2	0.15	320	800	21.0	48
Plexiglas	0.125	0.355	B	D	15	0.59	17	50	175	2.2	52
Plexiglas	0.25	0.757	B	D	53.8	1.05	2.33	102	370	6.2	52
Plexiglas	0.25	0.88	B	D	40.2	1.40	2.82	80	280	5.0	52
Pyralin	0.25	0.88	B	E	18.9	1.02	12.3	45	140	2.7	52
Lucite	0.1	0.316	A	D	10	0.48	4.5	108	280	1.6	48
Lucite	0.125	0.399	A	C	19	0.53	3.2	122	340	2.9	48
Lucite	0.18	0.533	A	C	33	0.69	1.86	140	430	4.5	48
Lucite	0.34	1.48	A	D	214	2.3	0.14	280	460	14.7	48
Safety glass	0.2	1.2	A	C	304	1.65	0.18	290	800	17.3	48
Safety glass	0.2	1.06	A	C	320	1.43	0.24	270	800	17.7	48
Window glass	0.1	0.628	A	C	73	0.99	0.69	195	595	8.0	48
Dural 175P	0.04	0.28	B	D	1	0.02	27	39	104	0.2	52
X			B	D	10	0.55	11	65	130	1.6	52

X --- Consolidated Aircraft Window No. 4 9 5/8" x 13" x 0.1"
Plexiglas window in 18" x 18" x 0.04" Dural panel.

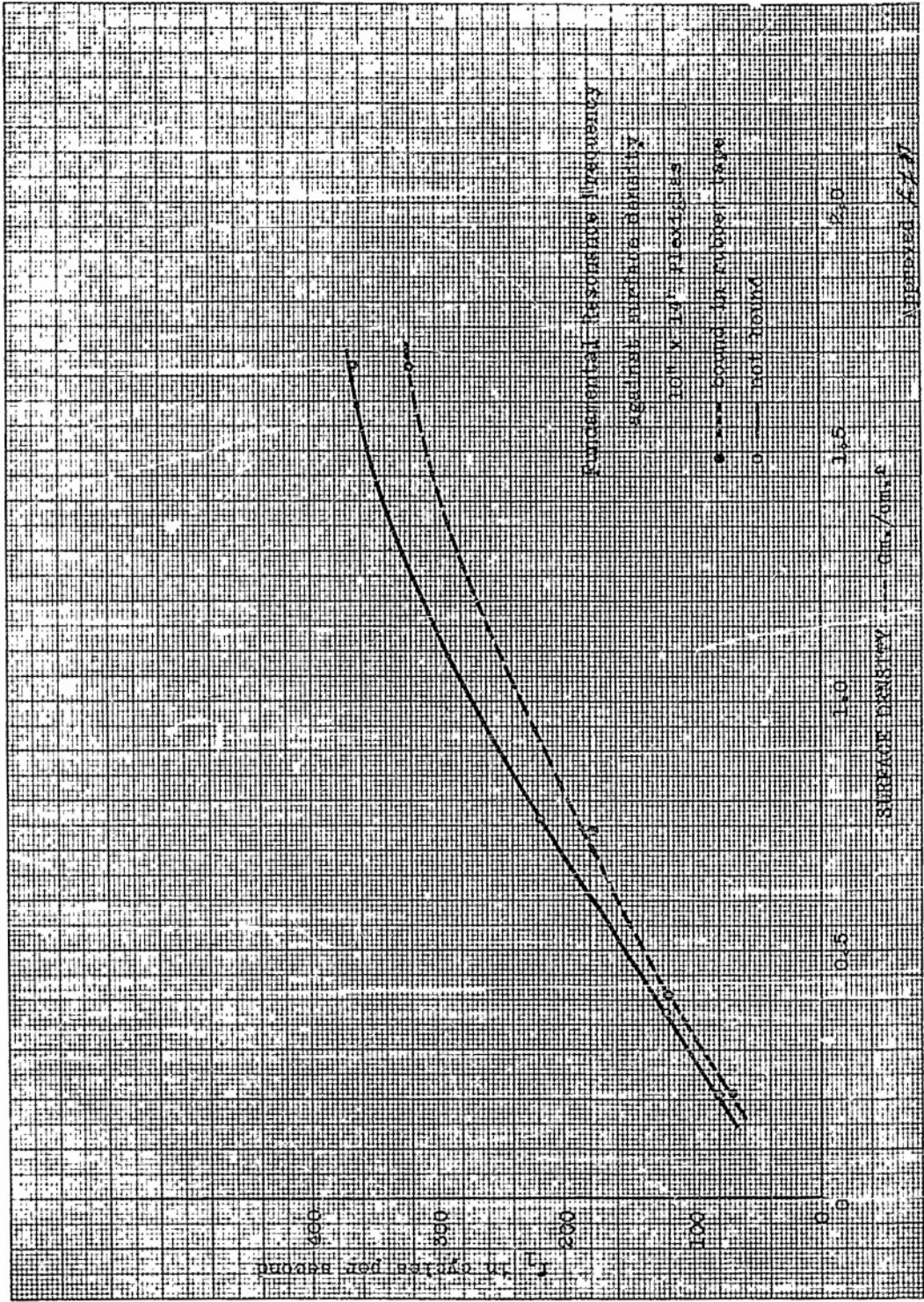

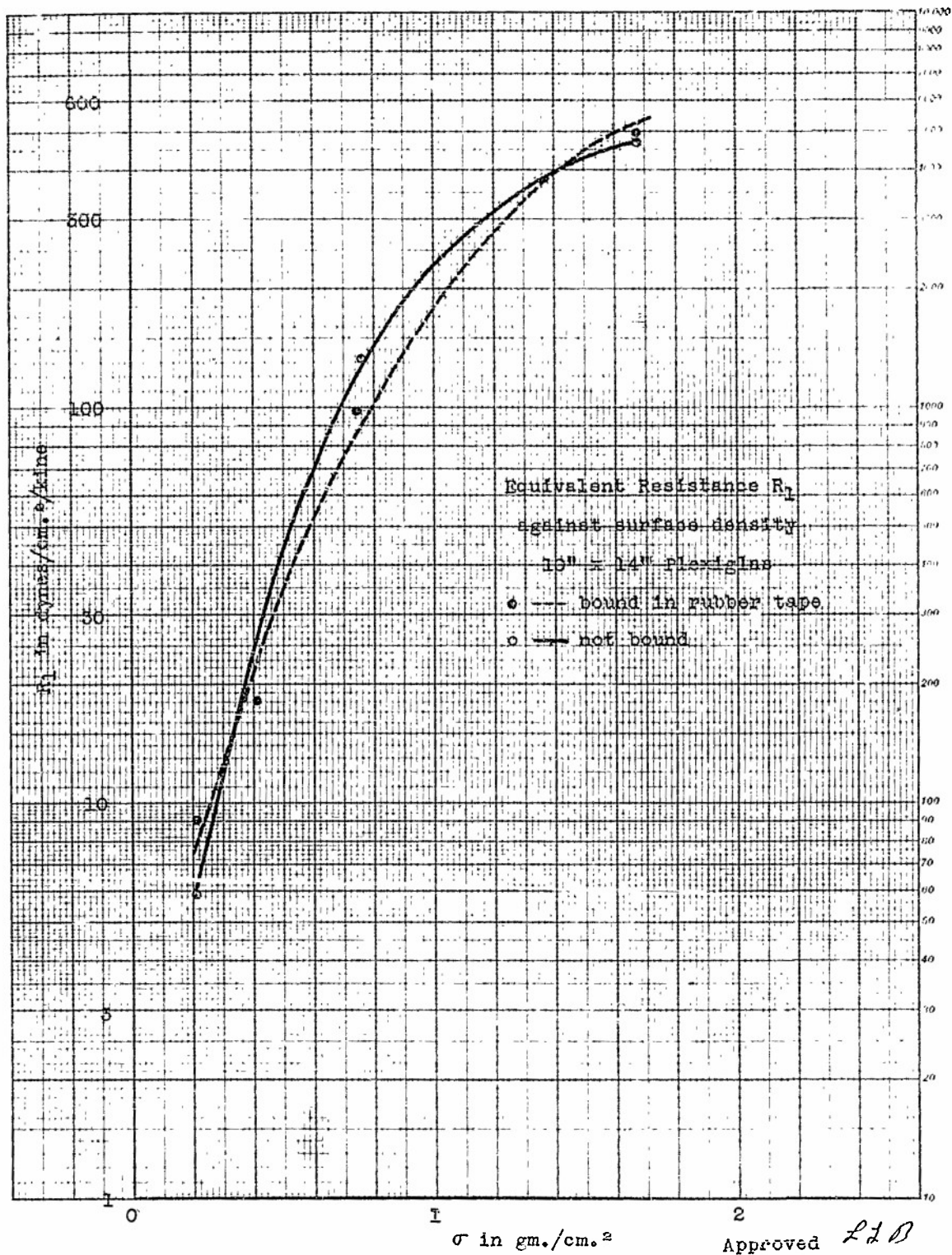

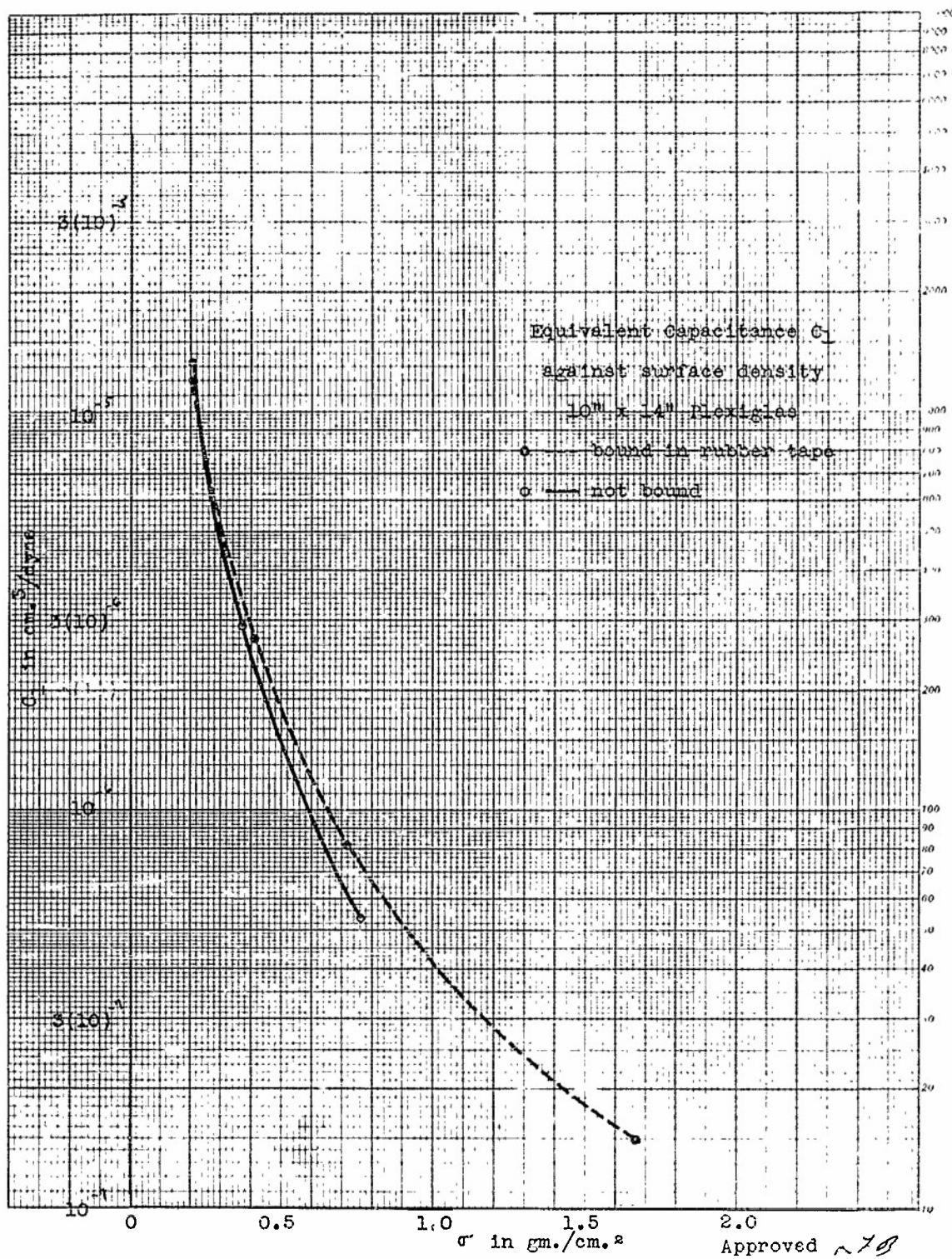

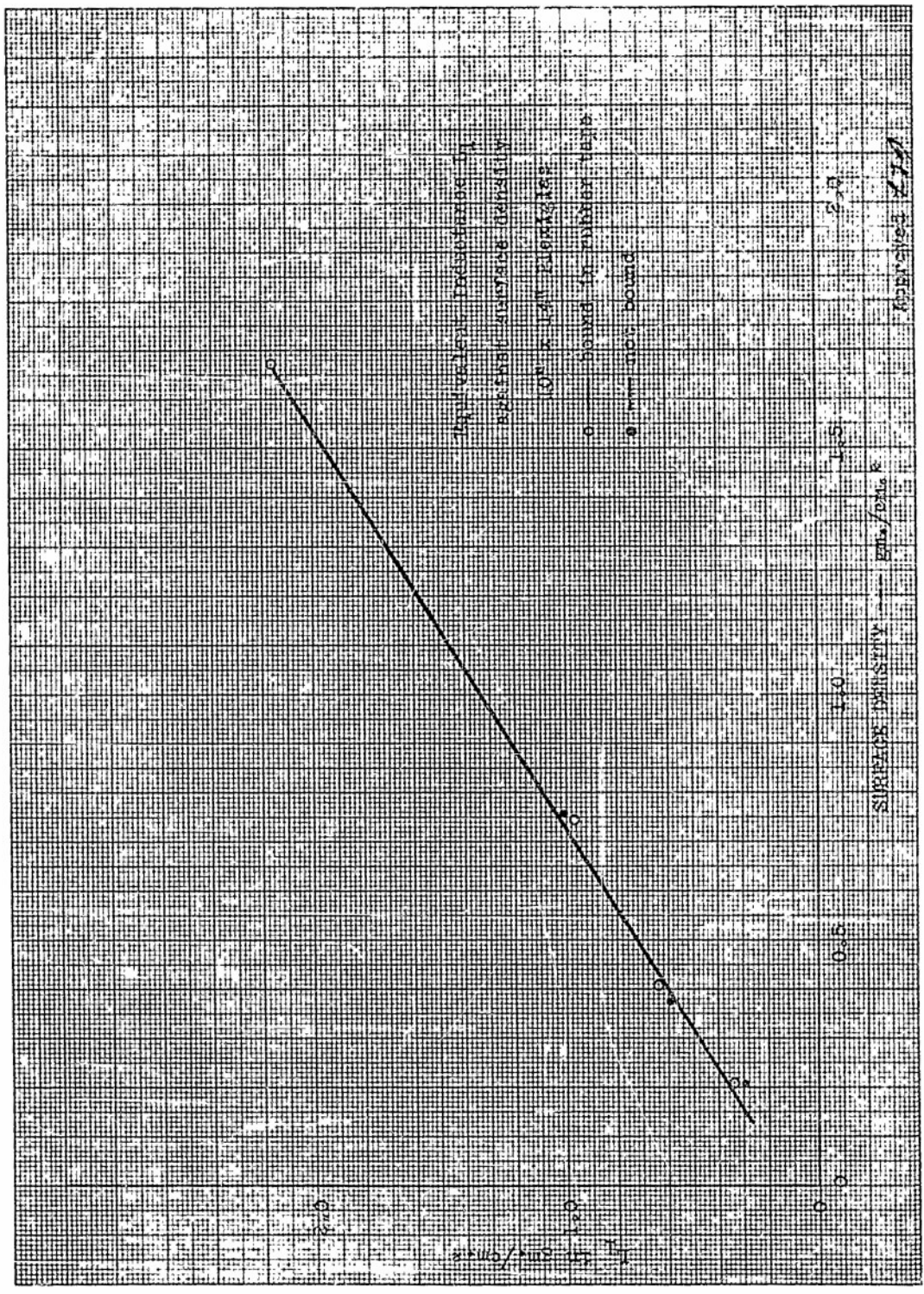

The dependance of the constants on dimensions of the window may be summarized in the following equations:

$$L_1 = 1.5 \sigma$$

for any material and any size.

$$C_1 = k_c A^2 / \sigma^3$$

where A is the area of the window and k_c depends somewhat on the material.

$$R_1 = k_r \sigma^2$$

where k_r depends on the material.

The last two equations do not represent the best possible fit to the experimental data and are not intended to be precise, but they do serve to give a rough idea of the dependance of the constants on dimensions.

e. Double Windows

The concept of equivalent circuits is very convenient for the treatment of double windows. At the low frequencies which are of interest in this problem the air space between the two components of a double window may be represented by a capacitance $C = \frac{d}{\rho c^2}$ where d is the distance between the windows in centimeters, ρ is the density of air in gm/cm³ and c is the velocity of sound in cm/sec. This capacitance occurs in the equivalent circuit as shown below.

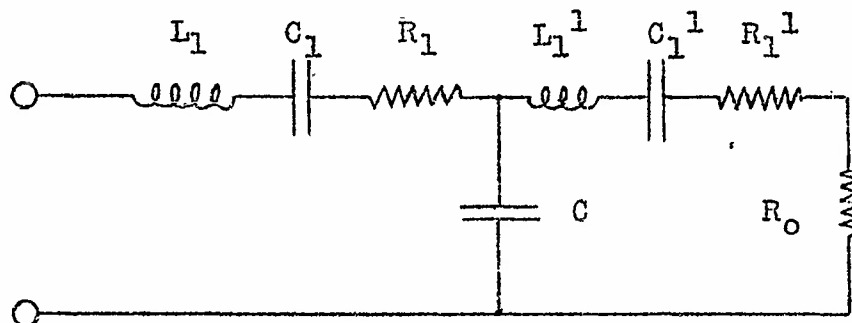

The window on which sound is incident is represented by L_1 , R_1 , and C_1 . The constants with primes represent the other component of the double window. The beneficial effects of C are

enhanced as the separation between the windows is increased but it turns out that in practice C has such a large impedance relative to the impedances of the window that its effect is almost negligible. A double window made of identical panes then behaves very much like a single window whose inductance is twice that of either of the components and whose capacitance is half that of either of the components. The equivalent resistance of the double window is approximately the sum of the resistances of the two components. It is interesting to compare the behavior of a double window made of identical panes with the performance of a single window whose thickness is twice that of either of the components of the double window. The resonance frequency of the double window is the same as that of either of its components and hence roughly half that of the single window. The equivalent capacitance of the double window is half that of either of its components and four times that of the single window. This means that at frequencies well below the resonance frequency of the double window the double window should give about six decibels more attenuation than that which would be given by either of its components but the single window should give about twelve decibels more attenuation than the double window does. These estimates completely neglect any effect of the air space between the components of the double window and hence are subject to some error. On page 241 are shown the experimental curves obtained for a single pane of 0.06" Plexiglas, for a double window with two panes of 0.06" Plexiglas separated by two inches, and for a single window of 0.125" Plexiglas. It will be seen from these curves that the behavior follows very closely the simple rules given above.

Because of the possibility of using heated liquids between double windows for the purpose of preventing frosting, it is important that a study be made of the acoustic properties of such windows. No experimental tests of this sort have been made yet but will be made soon. The capacitance C for a double window filled with liquid should be small enough to be completely negligible. The capacitance C_1 should be roughly half that for the single component panes (assuming the two panes to be identical). The inductance L_1 should be approximately 1.5 times the total weight of the window (including the weight of the liquid) divided by the area of the window. The value of R_1 can not be predicted but it may be possible to introduce a useful amount of dissipation by properly choosing the liquid and the spacing of the components. The resonance frequency should be lower than that of the single window and at low frequencies the attenuation should be inferior to that which should be obtained with a single window of the same weight. Tests will be made to confirm these predictions.

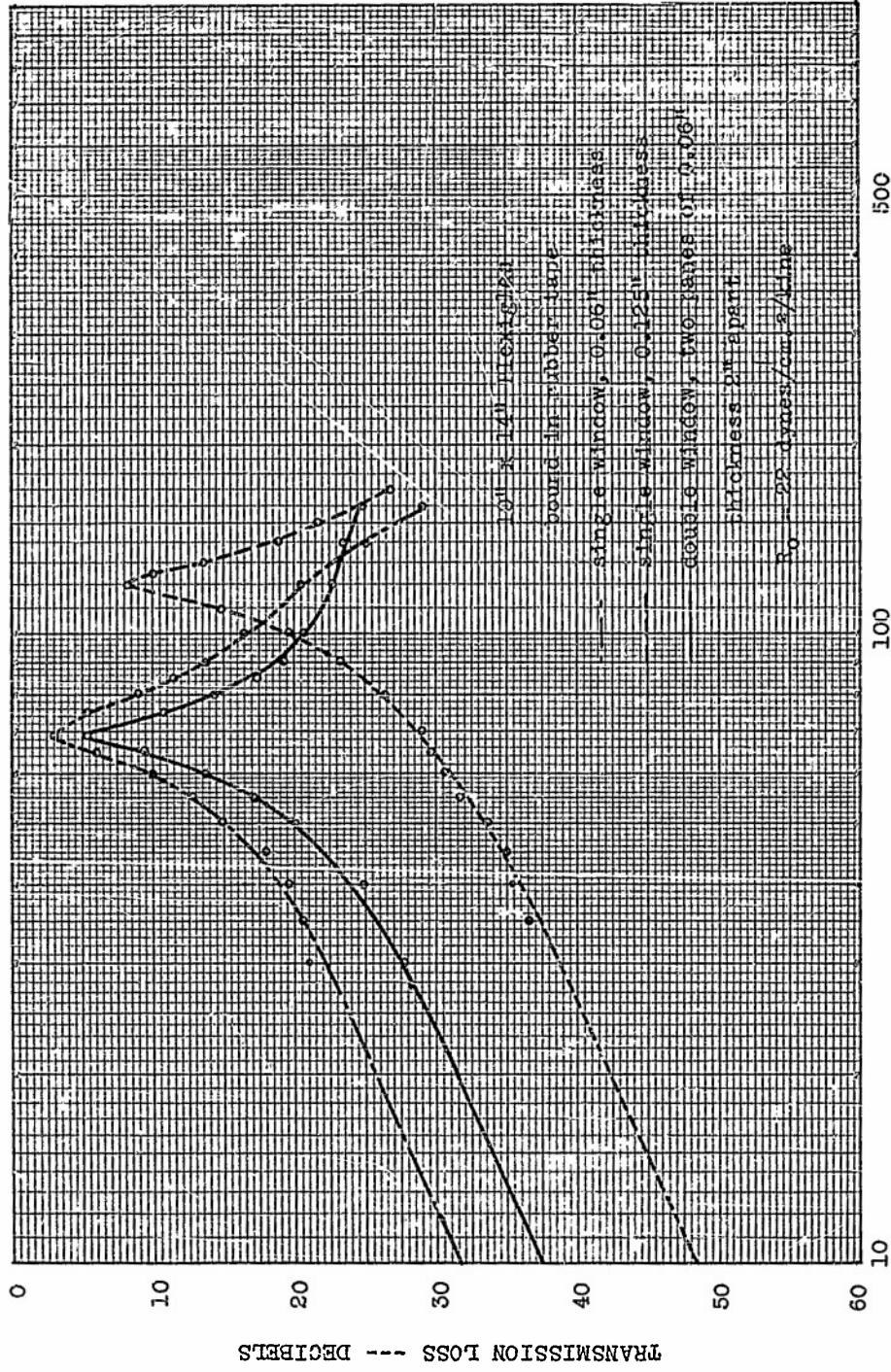

Approved *LKB*

F. Possible Improvements in Window Design

From the data which have been presented, it is seen that the most troublesome feature of windows is the poor attenuation produced at the fundamental resonance frequency. This is very important because most of the noise in aircraft occurs within a range of frequencies which includes the resonance frequency of windows now in use. There are three obvious methods of attack. The resonance frequency can be raised above the range in which most of the noise occurs or it can be lowered to a value far below this range or something can be done to improve the attenuation at resonance without appreciably changing the resonance frequency. If the acoustic problem alone could be considered, then the first solution would be the easiest and the most effective. Raising the resonance frequency means increasing the thickness of the window and the thickness of the Dural panel in which it is mounted. This increases the attenuation at high frequencies, at low frequencies, and at resonance peak. Unfortunately, this solution to the problem requires increasing weight of the windows and for that reason may not be suitable. It is felt, however, that the rapid increase in acoustic effectiveness of the window with increase in weight may warrant using thicker windows even at the cost of some weight.

Lowering the resonance frequency means making the supports for the window less stiff. This requires no added weight but unfortunately does not result in great improvement in the acoustic properties of the window because of the small mass reactance of windows now in use. It is possible, however, that some increase in the weight of the window together with a decrease in the stiffness of its mounting might give appreciable improvement without much cost of weight.

The third possibility is to increase the resistance in the equivalent circuit. This is accomplished by three methods: (a) In the case of Safetee Glass windows, the resistance is increased through the use of the dissipation which results from the distortion of the plastic filler between the glass panes. The relative motion of the glass panes is so small, however, that the dissipation introduced is not enough to be of great service. (b) Another possibility for increasing the attenuation at the resonance frequency is to couple a Helmholtz resonator to the air space between the components of a double window. This has the effect of shunting a series R, L, C circuit across the capacitance C shown in the equivalent circuit for double windows. If the resonator is tuned to the resonance frequency of the window it should improve the attenuation at this frequency. This scheme has been tried and was found to be unsuccessful because of the large resistance of the tube which joins the air space to the Helmholtz resonator. A volume of 960 cm³ was joined to the two inch deep

air space between two .06 Flexiglas windows with a rubber tube one inch in diameter and about six inches long. The length of the tube was adjusted to make the resonance frequency of the Helmholtz resonator coincide with that of the double window. The attenuation at the resonance frequency was increased about three decibels. (c) One other method of reducing the transmission at the resonance frequency has been tried. The center portion of a window moves with an amplitude which is large compared to that of the other parts. For this reason a small weight fastened to the center of the window has a very large effect in reducing the resonance frequency of the window. If the weight is not firmly fastened to the window but is dissipatively coupled then a large resistance is effectively inserted in the equivalent circuit and the transmission at resonance is much reduced. The results of one test are shown on page 245. The window was 18" square and was made of plate glass. It weighed 1727 grams and the piece of brass which was dissipatively coupled to its center weighed 176 grams. The resonance frequency was reduced from 140 cycles to 98 cycles and the attenuation at resonance was increased by about 18 decibels. From the point of view of a large acoustic improvement and small required weight this method seems very promising and it is proposed that more tests be made on it.

g. The Accuracy of the Measurements

It has not been possible to obtain a single termination whose impedance is that of a pure resistance and is constant over the entire range of frequency. At low frequencies the impedance becomes highly reactive and the resistance tends to increase somewhat from the rather constant value which it has at higher frequencies. This means that the measured attenuations "flatten" off at low frequencies. Two terminations were tried for the measurements on 10" x 14" windows. One of these terminations gave an impedance 22 dynes per cm² per kine which remained essentially constant and pure resistive down to a frequency of 30 c.p.s. but showed strong variations above about 200 c.p.s. The other termination gave an impedance of 48 dynes per cm² per kine from about 100 c.p.s. to 800 c.p.s. When the fundamental resonance frequency of a window was found to lie within the range over which both the terminations were good, it was possible to calculate equivalent constants from both sets of data. As examples of the agreement which is obtained from the two sets of data, the following comparison is given:

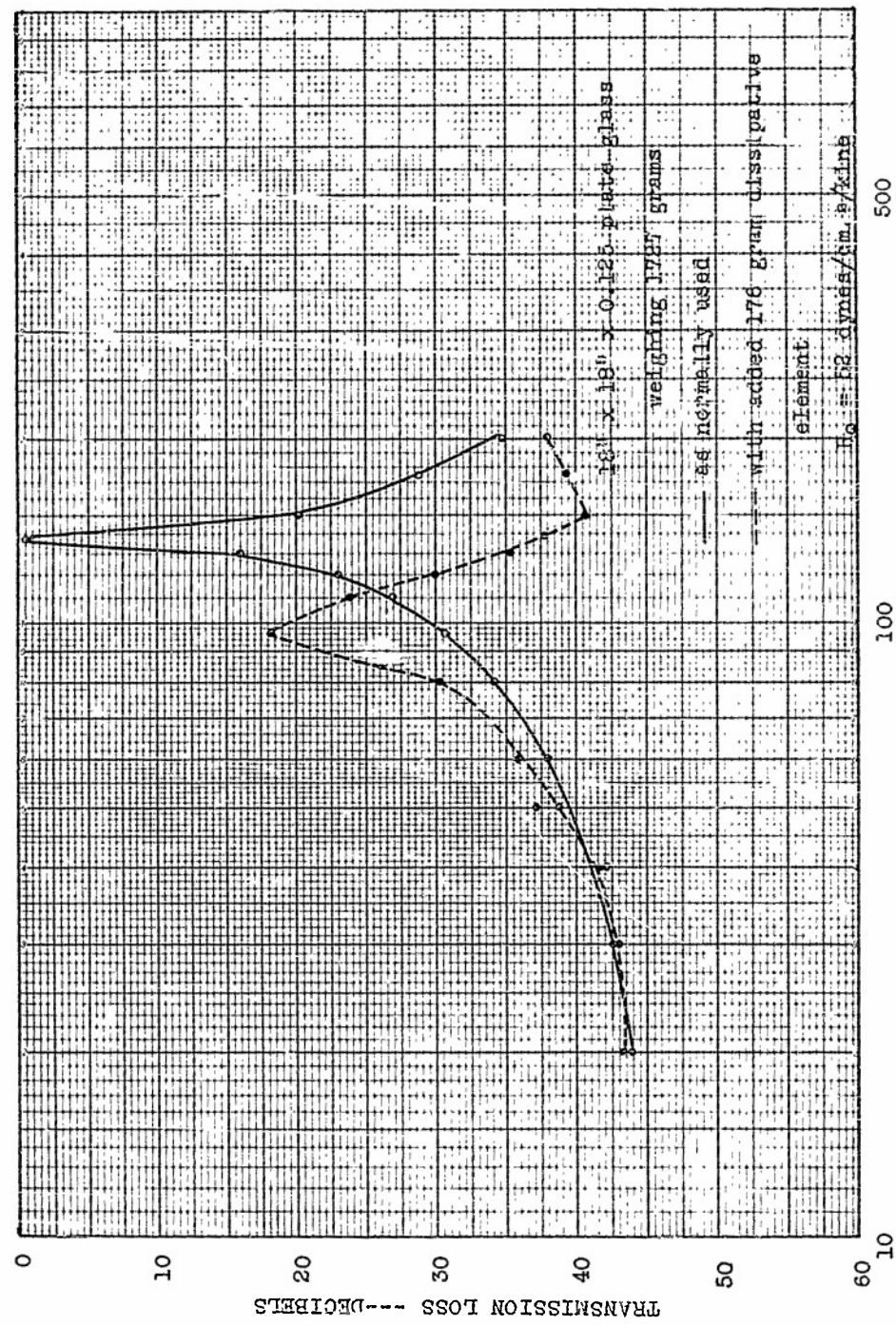

Approved *ZM*

10" x 14" Plexiglas WindowsBound in Rubber Tape

	R_1	L_1	C_1	f_1	R_0
gm./cm. ²	$\frac{\text{dynes}}{\text{cm. kine}}$	gm./cm. ²	$\frac{\text{cm.}^3}{\text{dyne}} \cdot 10^{-6x}$	c.p.s.	$\frac{\text{dynes}}{\text{cm. kine}}$
0.404	18	0.64	2.7	122	48
0.404	29	0.59	3.0	120	22
0.742	98	0.97	0.82	178	48
0.742	94	0.91	0.94	172	22

Since transmission curves have been taken with two different values of termination resistance it would be desirable to present curves which in some way average the results of the two measurements. The measured attenuation, however, depends upon the termination used and it is not possible to make a direct comparison between the results without making measurements on phase as well as amplitude. An indirect comparison can be made, however, by calculating the equivalent constants of the window from both sets of data. This sort of comparison has been made in the above table. It is further necessary to show that the window is equivalent to the circuit which has been drawn. As a step in this direction the curves of page 249 are shown. Equivalent constants were calculated from the experimental curve for $R_0 = 22 \text{ dynes/cm.}^2/\text{kine}$. Using these constants, Transmission Loss curves were calculated for both values of termination resistance. These calculated curves are drawn in on page 249. The points shown are the experimental points obtained with two terminations. It is seen that the experimental points do not follow the calculated below about 40 c.p.s. This is due to the capacitive reactance of the termination which becomes important at these frequencies. Since the impedance of the termination is known at all frequencies, it would be possible to make rather indirect corrections to the low frequency experimental points. It has seemed more simple and equally valid to extrapolate the attenuation curves on the low frequency end by calculating points from the measured element values in the equivalent circuit. All the curves shown in this report have been extrapolated in this way but the calculated points have not been shown. This explains the absence of points on the low frequency end of the curves.

An idea of the importance of the higher order resonances can be obtained from an examination of the transmission curves shown. When the second resonance frequency lies within the range of frequencies which is of interest it is not permissible to neglect the effects of L_2 , R_2 , C_2 , etc. The constants corresponding to these higher order resonances can be computed from the data which have been obtained but time has not been available for making these calculations.

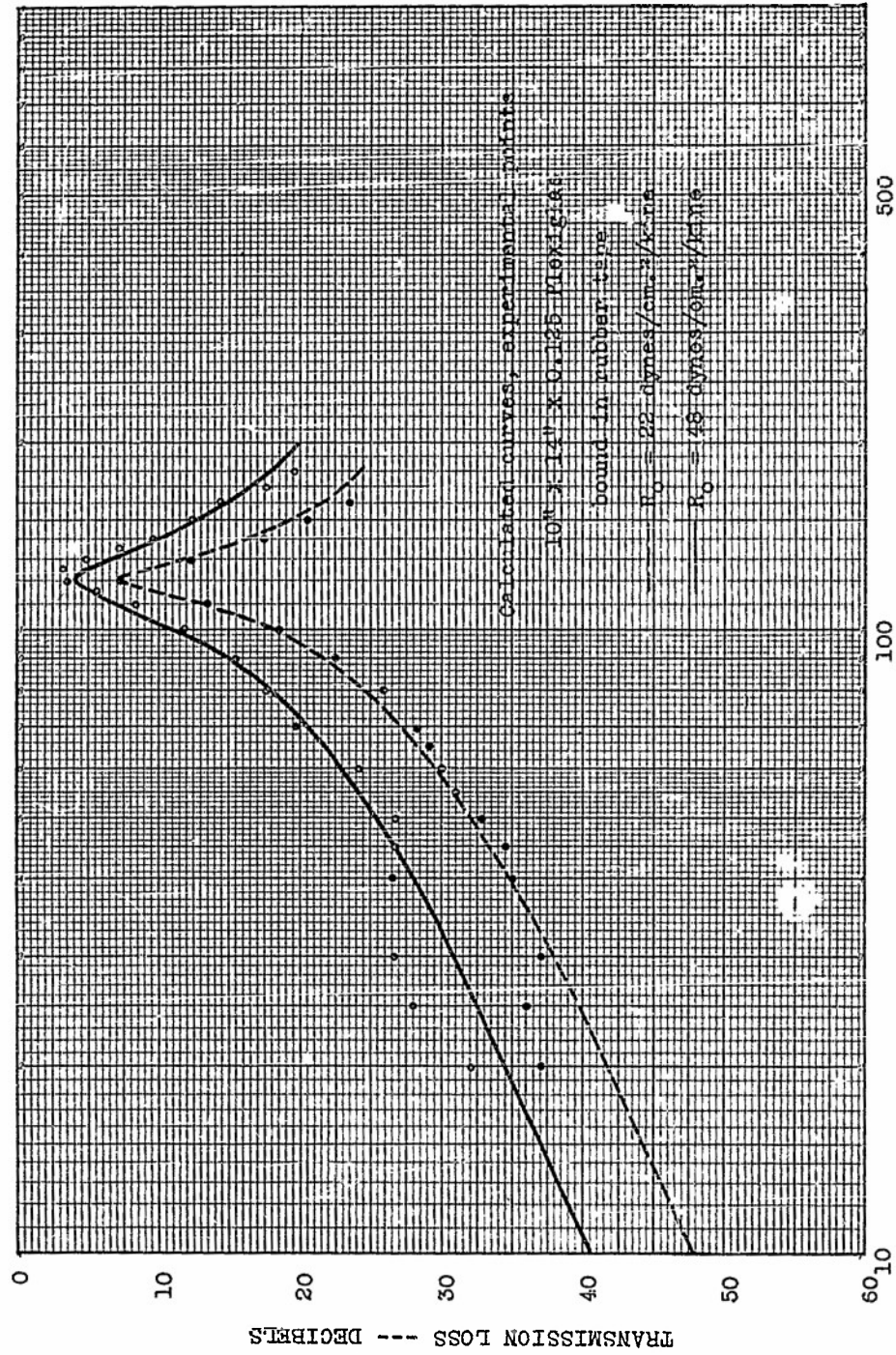

Approved *X 1/2*

VIBRATION INSULATION OF CHAIRS

a. Introduction

The objective of the work on chair vibration is to obtain as much insulation for airplane chairs as is compatible with the Services' mechanical requirements for them. The amount of insulation practically attainable may be limited by several factors, viz.: space, weight, mechanical strength (mounts should withstand 8 or 10 G), and the necessity for the pilot to "feel" his plane to some extent, i.e., mountings must not be too soft. Under shock excitation the mountings should not allow excessive amplitudes. An especial need for vibration insulation arises in Navy planes where hand-held navigation instruments are used, and in Army and Navy planes for precision bomb sighting.

The first problem on this project is to devise a laboratory apparatus and systematic measurement procedure which will determine the effectiveness of various systems of vibration insulation of chairs. Once this has been done, the second problem will be to devise effective vibration insulation systems for the standard types of chairs used by the Services. In the latter problem an effort will be made wherever possible to use standard commercial types of elastic mountings. Final judgement of the value of suggested chair insulation systems will, of course, rest with the pilots.

There are two factors which strongly affect the investigation:

1. The physiological and psychological effects of vibration, and the nature of their dependence upon amplitude, frequency, and direction of vibration are not very well known. Some work is being done in PROJECT II under the direction of Dr. S. S. Stevens to determine these effects. Until more specific information is available, we shall endeavor to provide effective vibration insulation for the chairs in all directions and for the frequency range between 10 and, say, 300 cycles per second.
2. The frequencies, amplitudes, and phase relations of the vibratory forces acting on a chair in an airplane can not very well be predicted, because they will vary with the type of plane, with motor and propeller speeds and types, with the type of chair, and with many other factors. This point must be borne in mind when one is designing a laboratory set-up for applying vibrating forces to a chair for test purposes.

Records of chair vibration (with a person in the seat) made under flight conditions on the B-17-C, B-18, and PBM types throw some light on the above situation. In general, the data which were obtained on these ships show that approximately equal amplitudes of vibration are present in all directions at any of several points on the chair, with peaks occurring at motor R.P.M. frequency and propeller blade passage frequency and their harmonics. In all cases the amplitudes of components above 200 c.p.s. are negligible in comparison to those below 200 c.p.s. A sample record from each of these ships showing a frequency analysis of vibration in a given direction at a point on the chair is shown on page 253.

The combination of a chair and pilot is at once seen to be a rather complex mechanical system. The chair in itself can only approximately be considered as a rigid body because of the flexibility of its elements and, in some cases, loose connections between component parts. With the pilot, who forms a second mechanical system of unknown constants (except mass), coupled to the chair, the complexity of the system is further increased.

If the chairs are to be insulated elastically to reduce vibration, mounting devices for them must provide effective insulation for various weights of pilot, for various positions of the pilot in the chair, and for various positions of the seat on an adjustable chair. Further, they must give effective insulation for all possible normal modes of vibration of the loaded chair, since for certain possible modes of vibration, the mass reaction on the mountings can be very small, and for others very large. This further complicates the problem of mounting design. It is extremely important that resonances of the system be avoided in the frequency range of important vibration components of the airplane in flight, since the amplitude of vibration of the chair at a resonance may be several times the amplitude with the chair rigidly mounted.

b. Conclusions on Chair Insulation

The results of experiments to date are primarily useful in pointing the way toward satisfactory methods of instrumentation and measurement. Each of the experimental procedures we have tried thus far has some drawbacks, consequently none of them by itself can be used as a routine method. From their shortcomings we foresee that simplification of the measuring technique may depend in a large measure upon the development of a suitable driving platform. Present efforts are directed toward this objective.

The use of standard vibration insulators at the mounting points of chairs may increase vibration problems unless care

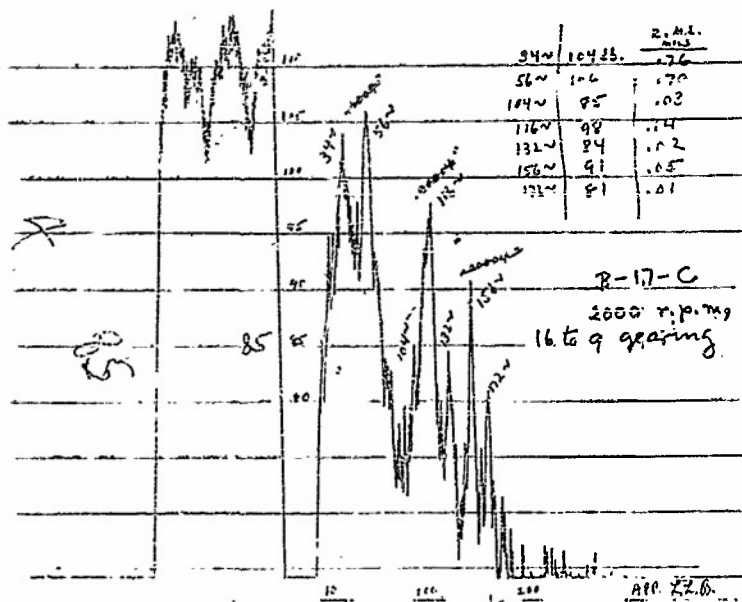

8-18 1850 r.p.m.
16 to 11 gearing

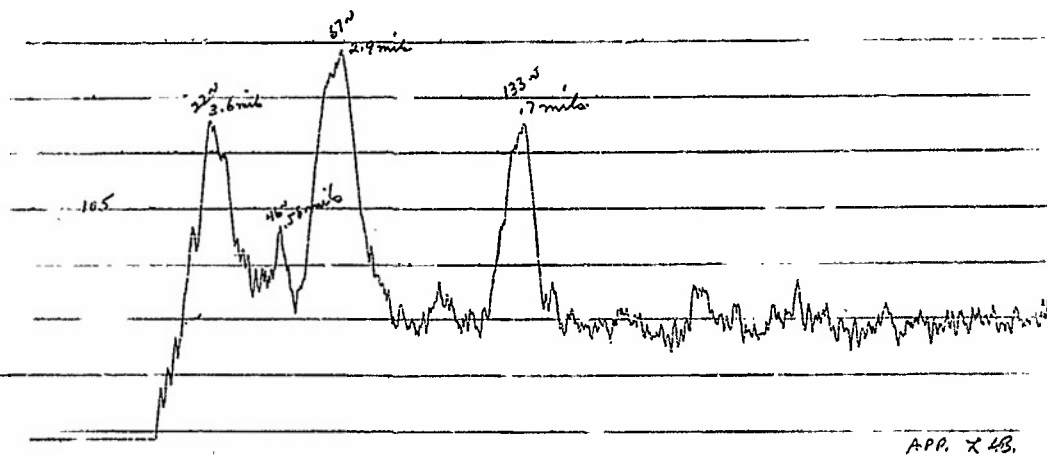

P.B.M. 1700 R.P.M.
16 to 9 gearing

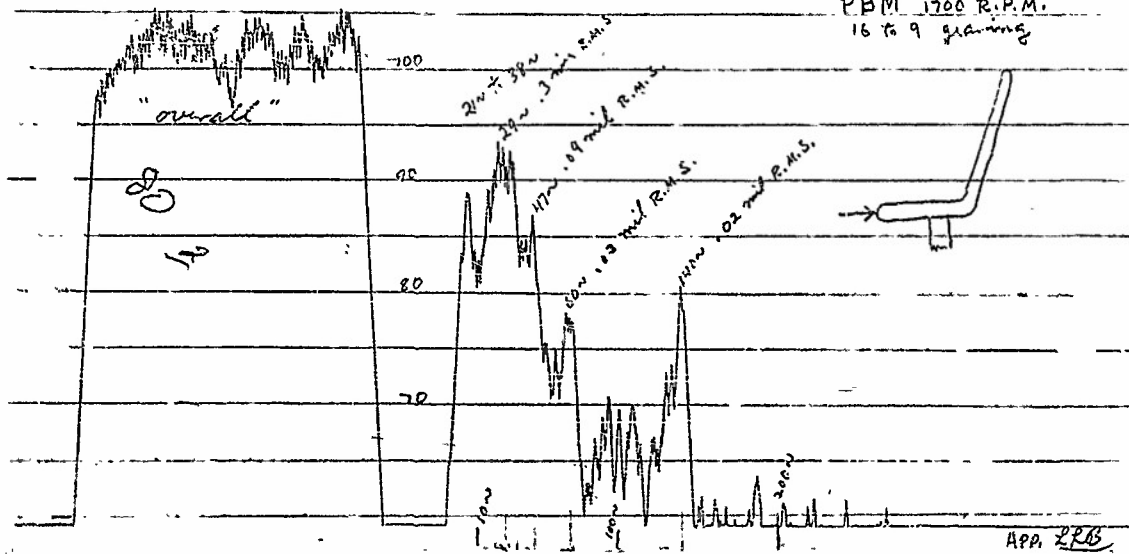

is used in selecting their position and orientation. Consider the situation briefly. The elastically mounted chair has six degrees of freedom, three of which are translational and three rotational. Intercoupling of two or more of these degrees results in combinational natural modes of vibration. Since the mass reaction presented to the insulators may be very small in many of these combinational modes, the insulators must have correspondingly low spring constants for motion in the directions of stress associated with such modes. This condition is usually difficult to obtain in a standard commercial insulator because the spring constants vary so widely with the direction of applied stress. Usually we know the constants of a mounting only for one or two types of stress, consequently we are unable to predict by analysis of the system what the frequencies of combinational modes will be, and some of them may fall within the range in which we wish to eliminate vibration. To facilitate analysis, therefore, mounting systems for the reduction of vibration should be designed in such a manner that the insulators are stressed only in directions for which we know the constants. We can then predict approximately the behavior of the system, and such predictions will direct the course of the experimental work in testing various mountings with the standard chairs.