

UNCLASSIFIED

AD NUMBER
ATI068929
CLASSIFICATION CHANGES
TO
unclassified
FROM
confidential
AUTHORITY
NRL ltr, 21 Oct 1971

THIS PAGE IS UNCLASSIFIED

Reproduction Quality Notice

This document is part of the Air Technical Index [ATI] collection. The ATI collection is over 50 years old and was imaged from roll film. The collection has deteriorated over time and is in poor condition. DTIC has reproduced the best available paper copy utilizing the most current imaging technology. ATI documents that are partially legible have been included in the DTIC collection due to their historical value.

If you are dissatisfied with this document, please feel free to contact our Directorate of User Services at [703] 767-9066/9068 or DSN 427-9066/9068.

**Do Not Return This Document
To DTIC**

~~CONFIDENTIAL~~
~~UNCLASSIFIED~~

NRL REPORT 3605

5360
cy 36

UNDERWATER LOOP RECEPTION PHENOMENA AND TECHNIQUES (U)

~~UNCLASSIFIED~~

DECLASSIFIED: By authority of
NRL Rpt 2628-601 Date *10/2/01*
Cite Authority _____
Naval Project 2628
Entered by _____ NRL Code _____



PLEASE RETURN THIS COPY TO
NAVAL RESEARCH LABORATORY
WASHINGTON 25, D. C.
ATTN: CODE 2028

Because of our limited supply you are requested to return this copy as soon as it has served your purposes so that it may be made available to others for reference use. Your cooperation will be appreciated.

PANC-NRL-20-420

~~UNCLASSIFIED~~

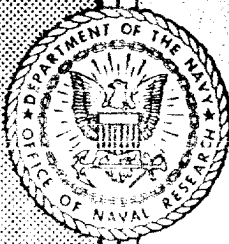

NAVAL RESEARCH LABORATORY

WASHINGTON, D.C.

APPROVED FOR PUBLIC RELEASE
DISTRIBUTION UNLIMITED

~~CONFIDENTIAL~~
~~UNCLASSIFIED~~

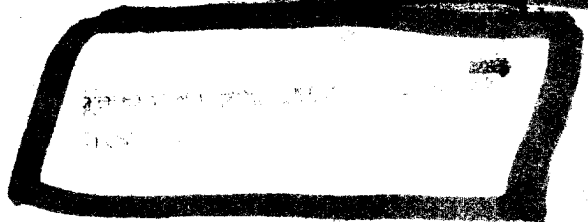

ADDRESS REPLY TO
DIRECTOR, NAVAL RESEARCH LABORATORY
WASHINGTON 25, D. C.
AND REFER TO:

CONFIDENTIAL
NAVAL RESEARCH LABORATORY
WASHINGTON 25, D. C.



C-2000-170/50 brg

12 June 1950

CONFIDENTIAL

From: Director, Naval Research Laboratory
To: Distribution List

Subj: NRL Report 3605, "Underwater Loop Reception Phenomena and
Techniques; correction of

Encl: (1) Revised page 6 for subject report

1. Enclosure (1) corrects several errors in Figure 7, the last paragraph on page 6 and the first line of page 7 of subject report.
2. Upon the insertion of this revision sheet, the first line on page 7 should be stricken out.

F. R. FURTH

M. E. Jansson

M. E. JANSSON
By direction

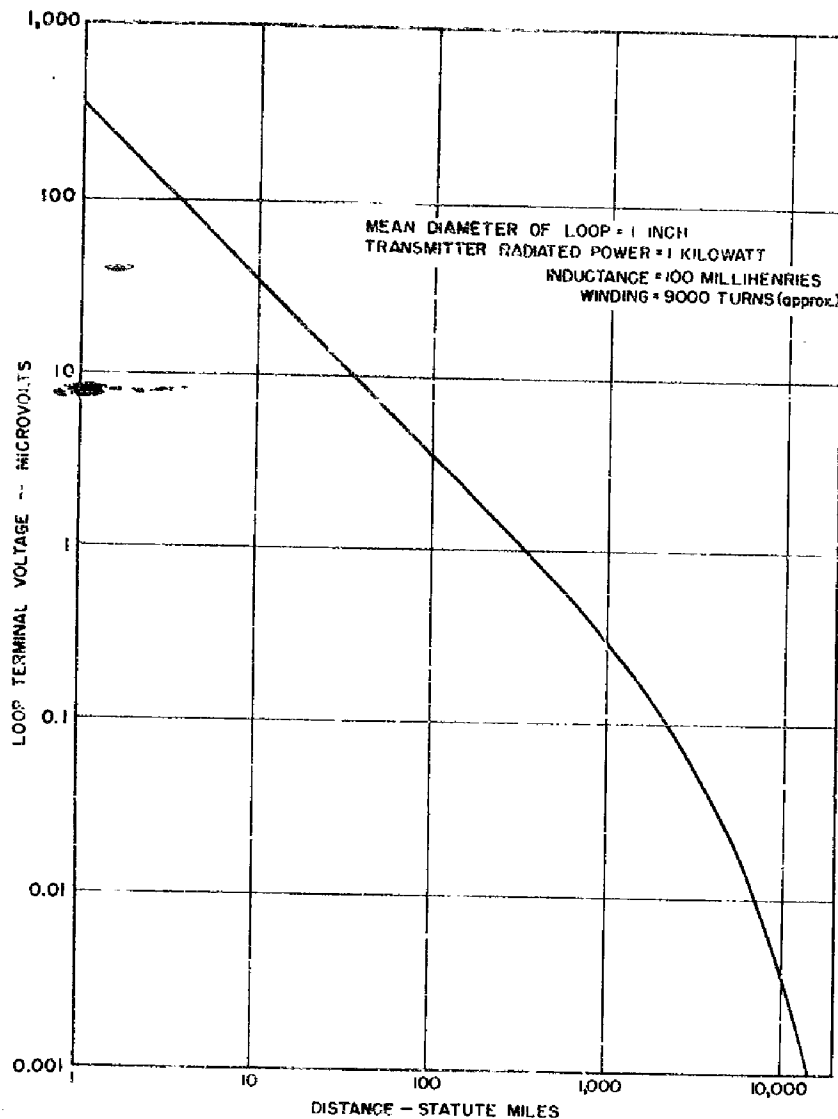

Figure 7 - Computed terminal voltage of loop antenna
in 20 kc ground-wave field

yield the approximate voltage impressed on the control grid of the first tube of the receiver used in the system. The voltage obtained with loops of larger mean diameter can also be approximated by multiplying the voltage from the graph by the ratio of the new diameter to one inch. The induced voltage for a transmitter radiated power other than one kilowatt can be obtained by multiplying the graph voltage values by the square root of the power ratio.

For instance, the terminal voltage e for the one-inch 9000-turn loop at 1000 miles is 0.3 microvolts. With the loop circuit resonated using a suitable condenser, and with the over-all loop system $Q = 25$, the voltage at the grid of the first tube is $eQ = 0.3 \times 25 = 7.5$ microvolts. With a loop having a mean diameter of 12 inches instead of one inch, the grid voltage is $eQ(d_2/d_1)$ (where d_2/d_1 is the ratio of loop diameters), which is 90 microvolts. For a transmitter radiated power of 100 kilowatts instead of one kilowatt, e_g (the grid voltage) = $eQ(d_2/d_1) \sqrt{P_2/P_1} = 90 \sqrt{100} = 900$ microvolts, where P_2/P_1 is the transmitter power ratio.

Assuming that 1.5 microvolts at the control grid of the first tube in the receiver repre-

DISTRIBUTION

CNO		
Attn: Code OP-413-B2		5
Attn: Code OP-20		1
Attn: Code OP-34		1
ONR		1
Attn: Code 482		2
Attn: Code 470		1
Attn: Code 466		2
BuAer		2
Attn: Code EL-4		1
Attn: Code EL-92		1
Attn: Code TD-4		1
BuShips		1
Attn: Code 831		10
Attn: Code 833		15
Supt., USNPGS		1
ComOpDevFor		1
CO, ONR, Boston		1
CO, USNUSL, Fort Trumbull		2
Dir., USNEL		2
CDR., USNOTS		2
Attn: Reports Unit		2
SNLO, USNELO		1
BAGR, CD, Wright-Patterson AFB		1
Attn: CADO-D1		1
Ch. of Staff, USAF		1
OCSigO		1
Attn: Ch. Eng. & Tech. Div., SIGTM-S		1
CO, SCEL		2
Attn: Dir. of Eng.		2
CG, AMC, Wright-Patterson Air Force Base		1
Attn: Eng. Div., Electronics Subdiv., MCREEO-2		1
CO, Watson Labs., AMC, Red Bank		1
Attn: Ch. Eng. Div., WLENG		1
Attn: ENR		1
CO, Air Force Cambridge Res. Labs.,		1
Attn: ERCTL		1
Attn: ERRS		1
NBS		1
Attn: CRPL		1
RDB		1
Attn: Library		2
Attn: Navy Secretary		1
Naval Res. Sec., Science Div., Library of Congress		2
Attn: Mr. J. H. Heald		2

CONTENTS

Abstract	iv
Problem Status	iv
Authorization	iv
INTRODUCTION	1
PROPAGATION	1
MODE OF OPERATION OF SUBSURFACE LOOP ANTENNAS	3
FIELD STRENGTH ALONG THE EARTH'S SURFACE	4
VOLTAGE INDUCED IN A LOOP IN AIR	5
THE BOUNDARIES OF UNDERWATER RECEPTION	7
DIRECTIONAL RECEPTION WITH UNDERWATER LOOPS	7
NONDIRECTIONAL LOOPS	8
CROSSED-LOOP STRUCTURES	10
EFFECT OF IRON CORE ON LOOP EFFICIENCY	10
EFFECT OF LOOP DIAMETER ON PICKUP	11
EFFECT OF DECREASING SUBMERGENCE ON LOOP DIMENSIONS	11
EFFECT OF LOOP CIRCUIT Q ON RECEIVING SYSTEM SENSITIVITY AND BANDWIDTH	12
INCREASE IN LOOP SYSTEM Q EQUIVALENT TO DECREASE OF LOOP SUBMERGENCE	13
SUGGESTED UNDERWATER LOOP COLLECTOR SYSTEM	13
CONCLUSIONS	15
RECOMMENDATIONS	15
ACKNOWLEDGMENT	15
BIBLIOGRAPHY	16
APPENDIX - Variation in VLF Signal Strength Due to Simultaneous Reception of Ground and Sky Waves	17
NOTE ON RECEIVER CIRCUITRY FOR VLF UNDERWATER RECEPTION	18

ABSTRACT

The underwater propagation of radio signals and the mode of operation of submerged loop antennas are briefly considered. Directional and nondirectional reception are discussed, and an omnidirectional loop circuit is presented. Study of the influence of submerged depth and iron cores on loop dimensions, and the consideration of boundary depths for effective reception, lead to a suggested omnidirectional loop system in which the loop structure is mounted on or suspended from a submerged buoy and is located within the boundary layer of long-distance reception.

PROBLEM STATUS

This report presents a brief general summary of underwater reception from the technical operational point of view. Further detailed technical work on the problem is continuing.

AUTHORIZATION

NRL Problem R10-43R (BuShips Problem S1083.1)
NE 120-201

CONFIDENTIAL

UNDERWATER LOOP RECEPTION PHENOMENA AND TECHNIQUES

INTRODUCTION

The phenomenon of underwater and underground propagation of radio waves has been known for many years. Some submarines in World War I were equipped with so-called "French" coils for undersea radio reception, and at about this same time the reception of radio signals with antennas buried in the ground was demonstrated in the United States. A submerged U.S. submarine was able in 1919 to receive in Long Island Sound long-wave signals from Nauen, Germany. Submarines were equipped for underwater reception during World War II, the British, for instance, transmitting from Rugby, England, to submerged subsurface craft patrolling the Mediterranean Sea. Two types of underwater receiving adapters were developed for the U.S. Navy just prior to and during this last war. With one of these adapters (developed at NRL) the submarine Sea Lion while submerged to periscope depth (loop depth about 15 feet) at Pearl Harbor, was able in 1940 to get a good copy from the Annapolis transmitter NSS.

There are, however, certain fundamental limitations encountered in subsurface radio reception which must be recognized and upon which operational techniques must be based. First, only a small part of the radio field energy existing above the surface appears below. Second, the energy which does penetrate the surface is very rapidly absorbed by the subsurface medium (water or earth), so that the field-strength attenuation per foot of increasing depth is very considerable. Third, the attenuation per foot of increasing depth of submergence becomes greater as the frequency of the radio carrier wave becomes higher.

These various effects result in limitations which, in sea water, restrict long-distance reception to a frequency range with a practical upper value of about 35 or 40 kilocycles and to a submerged depth for the top member of the antenna of not much more than about 20 feet. Failure to appreciate these limitations will seriously curtail the usefulness of underwater receiving equipment.

PROPAGATION

At very low radio frequencies a radiated wave in air may be considered as advancing with its electric vector almost, but not quite, perpendicular or normal to the surface of the earth. This is the case for a vertically polarized horizontally advancing wave, which is the condition essentially obtained in long distance VLF reception. The slight forward tilt of the electric vector may be considered as being caused by refractive effects resulting from the difference in wave propagation velocity above and below the surface. As a consequence, there is generated a downward component of the wave, so that, in addition to the

CONFIDENTIAL

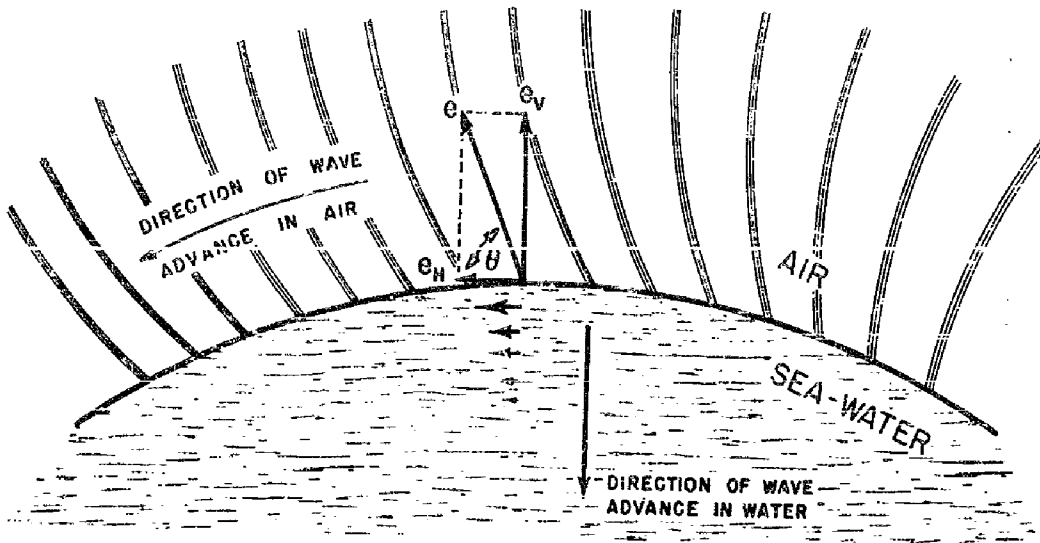

Figure 1 - Electric vector of a radio wave above and below the surface

horizontally advancing wave front component which moves parallel to and above the surface, there will be a vertically advancing component which moves downward from the surface toward the center of the earth.

Figure 1 in somewhat exaggerated fashion illustrates this phenomenon for a particular instant and position on the earth's surface. The angle θ is usually between 89 and 90 degrees, so that the electric-vector component under water is generally quite small relative to the component in air. Figure 2 shows the field strength of the radio wave in sea water immediately under the surface, as compared to its field strength in air. The loss in field energy is high, ranging from about 70 decibels at 10 kc to about 48 decibels at 1000 kc.

The horizontally polarized underwater component of the original vertically polarized wave has a much lower velocity because of the high conductivity of sea-water. The wavelength of the radio wave therefore becomes much less than its above-surface value. In addition, its energy is dissipated in the highly conductive salt water to the degree indicated by Figure 3, from which it is evident that only the lowest practicable carrier frequencies

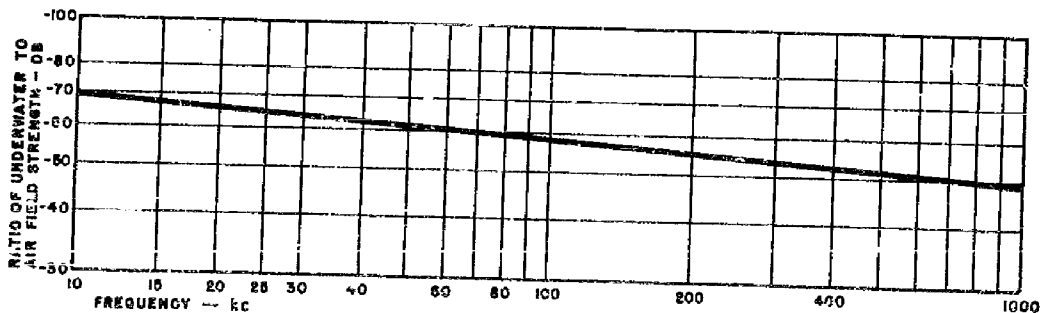

Figure 2 - Computed strength of radio field just under surface of water relative to field strength in air

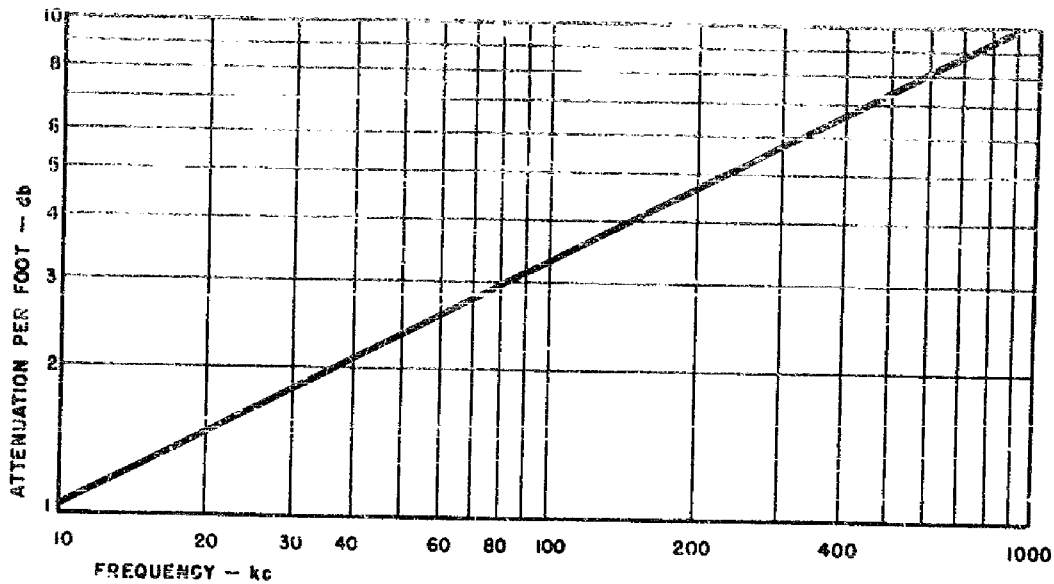

Figure 3 - Computed attenuation of underwater radio field per foot of submergence

will provide with increasing submergence a loss of signal strength tolerable in an operating system.

MODE OF OPERATION OF SUBSURFACE LOOP ANTENNAS

Loop or coil antennas are particularly well suited for low-radio-frequency collector applications. They can readily provide the normally desirable characteristic of low antenna impedance, transformable to any reasonable value by simple means. In addition, they can allow essentially complete control of the antenna circuit in equipment design, so that highly efficient utilization of antenna induced energy is feasible.

A loop antenna operating in air provides a terminal voltage which is a function of the relative time of arrival of a wavefront at the two opposite sides of the coil which are parallel to the electric vector (Figure 4 a). In other words, the magnetic flux lines of the radio wave cut through first the nearer side of the coil and then the farther side. The voltages induced in these two elements (e_1 and e_2) are almost absolutely equal, because in practical designs the attenuation of the radio wave over the small space difference between the forward and aft legs of the loop is negligibly small. Since the two induced potentials are equal and in opposition in the loop winding, the net voltage e_0 appearing at the loop terminals is only that resulting from the phase difference between the two induced voltages as caused by difference in time of arrival of the wave front at the nearer and farther sides of the loop. This is shown by the vector representation in Figure 4 b.

The same loop under water has the same two voltage components (e_1 and e_2) induced in its winding, except that in this case the electric vector is horizontal and the voltages are induced in the horizontal members of the loop. The voltage e_1 , however, is greater than e_2 since the radio field is attenuated by the water with increasing depth (Figure 4 d). The phase angle θ between e_1 and e_2 is also much greater than for the loop in air, because the wavelength has greatly decreased as the result of the much lower velocity of propagation of radio waves in water (about a thousandth of the velocity in air). The output voltage of the loop e_0 is, however, mainly the resultant of the difference in amplitude of e_1 and e_2 caused by field attenuation in the water, with phase difference accounting for only about 25 percent (2 decibels) or less of the total output voltage in the VLF range.

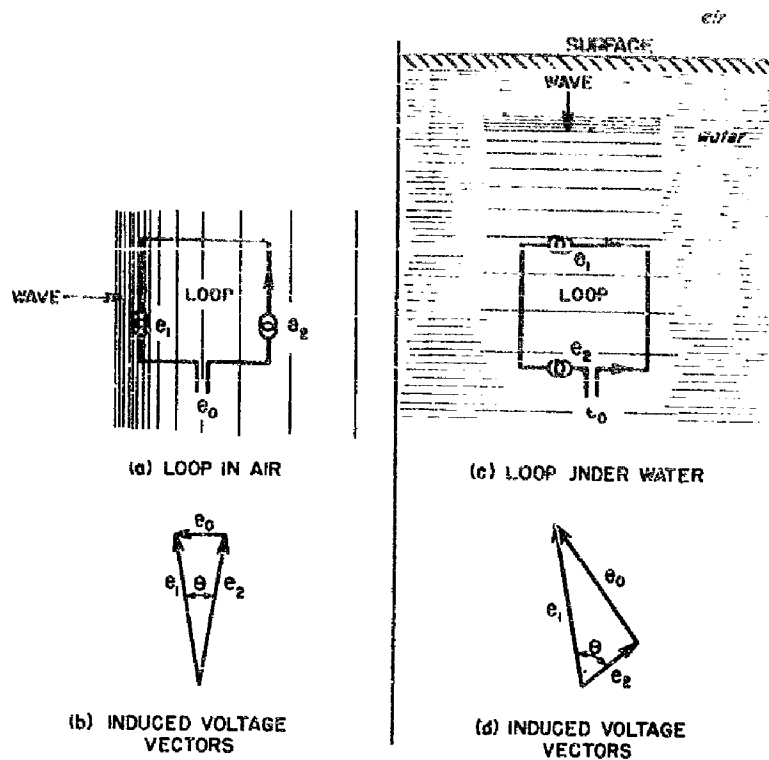

Figure 4 - Induced voltages in air and underwater loops

The mode of operation of the loop in water produces a great improvement in loop pick-up efficiency. At 20 kilocycles, for example, underwater operation results in an increase in output voltage (for a given field strength at the loop) of about 1650 times, or about +64 decibels, as compared to the same loop in air. However, the loss in field strength encountered in transition from the air above the surface to the water immediately under the surface is 66 decibels at 20 kc (Figure 1). Thus transfer of a loop from above the surface to just below the surface results in a loss of only 2 decibels in output voltage. With increased depth of submergence, the output voltage decreases rapidly (about 1.5 db per foot at 20 kc), as indicated in Figure 5.

It is evident that the most important effect in underwater radio reception is the rapid loss of signal strength with increasing submergence. The attenuation per foot of depth is least at the lowest frequencies, and only the VLF range of 15 to perhaps 35 or 40 kc appears at all practicable for underwater reception when the receiving antenna is required to be more than a few feet below the surface.

FIELD STRENGTH ALONG THE EARTH'S SURFACE

Very-low-frequency transmission of radio signals is also desirable for submerged reception for a number of other reasons. Propagation characteristics in the 15- to 35-kc region result in a strong ground wave which follows the earth's curvature and produces good signal strength at great distances. The effect of sky waves is discussed briefly in the Appendix. Figure 6 shows the computed field strength obtained for the radiated power of 1

kilowatt at 20 kilocycles with increasing distance along the surface of the earth, this surface being mainly water. At 1000 miles, for instance, the very respectable field strength of 150 microvolts per meter is obtained.

VOLTAGE INDUCED IN A LOOP IN AIR

Figure 7 is a graph of the terminal voltage, in air, of an untuned loop one inch in mean diameter and with an inductance value of 100 millihenries. This inductance is in the neighborhood of the values generally used for the tuned circuits of receivers in the 15- to 35-kc range. The graph shows the decrease in loop output voltage with increasing distance for a ground wave of 20 kc. Multiplication of the graph voltage values by the effective Q of the loop will

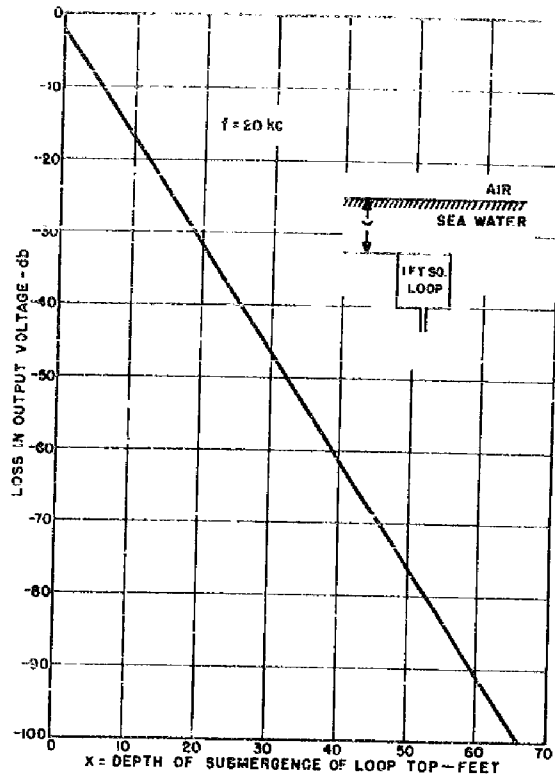

Figure 5 - Output voltage of a submerged loop relative to same loop above the surface

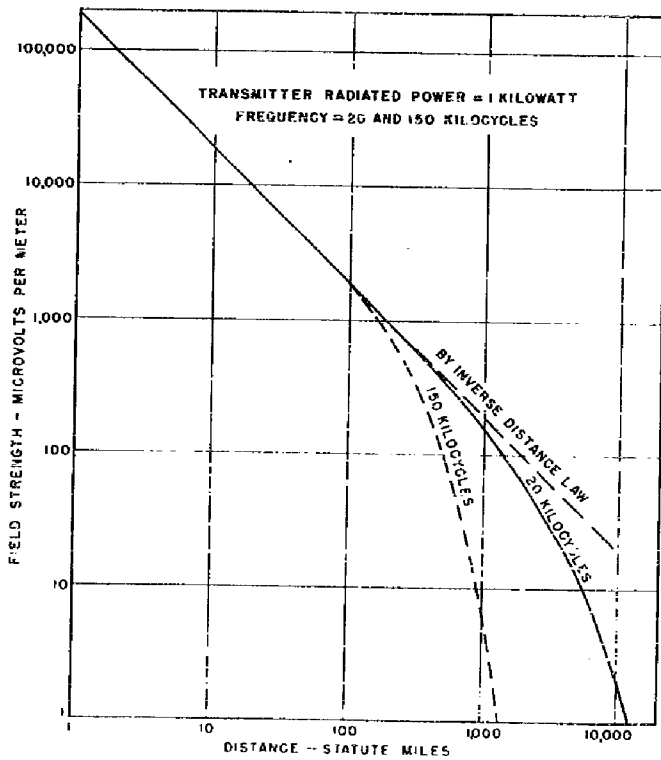

Figure 6 - Computed ground-wave field strength as a function of distance over sea-water

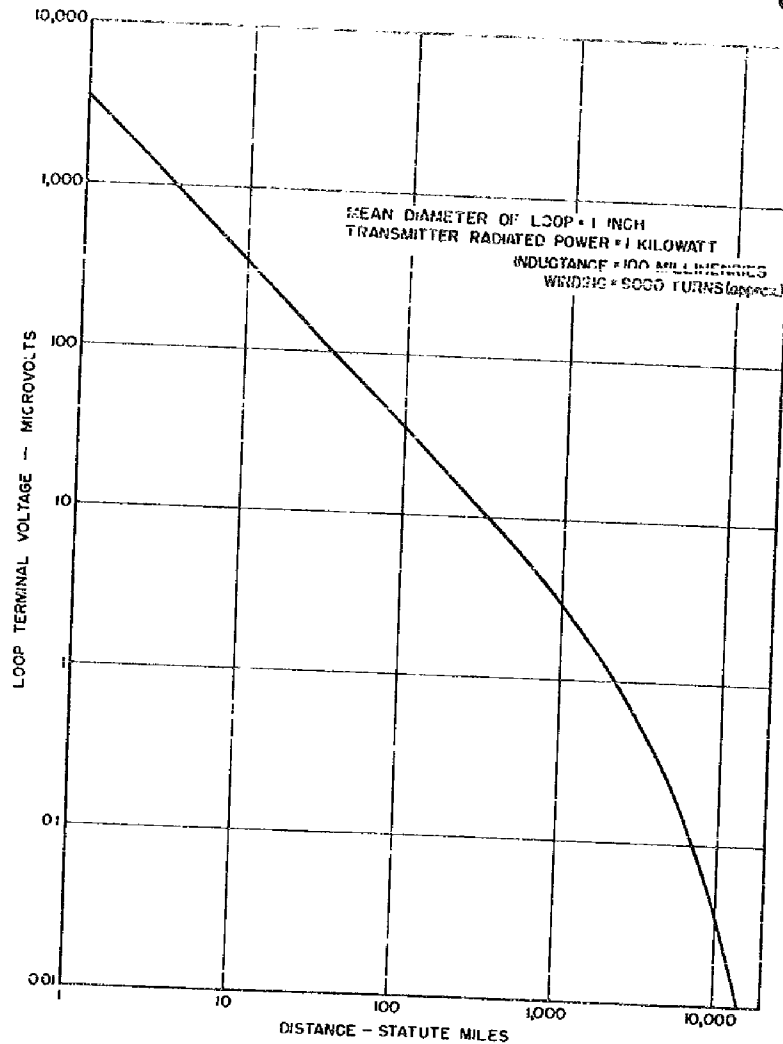

Figure 7 - Computed terminal voltage of loop antenna
in 20 kc ground-wave field

yield the approximate voltage impressed on the control grid of the first tube of the receiver used in the system. The voltage obtained with loops of larger mean diameter can also be approximated by multiplying the voltage from the graph by the ratio of the new diameter to one inch. The induced voltage for a transmitter radiated power other than one kilowatt can be obtained by multiplying the graph voltage values by the square root of the power ratio.

For instance, the terminal voltage e for the one-inch 9000-turn loop at 1000 miles is 3 microvolts. With the loop circuit resonated using a suitable condenser, and with the over-all loop system $Q = 25$, the voltage at the grid of the first tube is $eQ = 3 \times 25 = 75$ microvolts. With a loop having a mean diameter of 12 inches instead of one inch, the grid voltage is $eQ (d_2/d_1)$ (where d_2/d_1 is the ratio of loop diameters), which is 900 microvolts. For a transmitter radiated power of 100 kilowatts instead of one kilowatt, e_g (the grid voltage) = $eQ (d_2/d_1) \sqrt{P_2/P_1} = 900 \sqrt{100} = 9000$ microvolts, where P_2/P_1 is the transmitter power ratio.

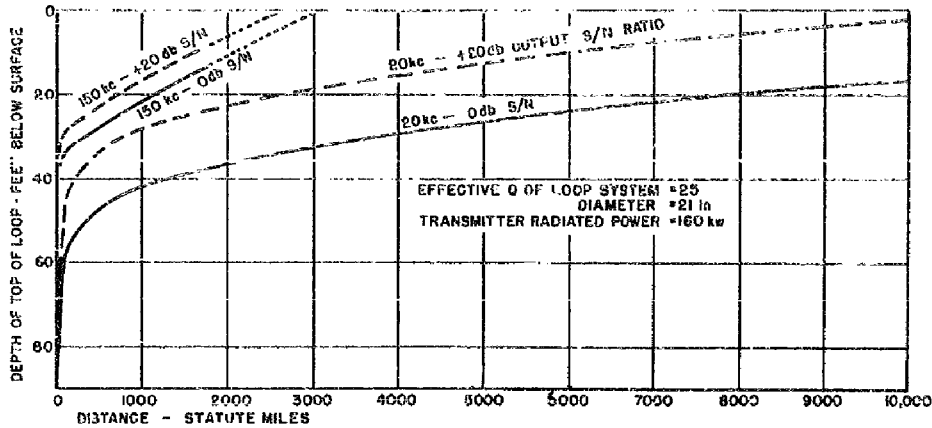

Figure 8 - Computed boundary depths of reception at 20 kc and 150 kc with a 21-inch air-core loop

Assuming that 15 microvolts at the control grid of the first tube in the receiver represents a signal just readable through the circuit noise, we see from Figure 5 that we can submerge the loop to about 40 feet before losing the signal. At 5000 miles, however, the submerged depth of the loop must not exceed about 25 feet. It is interesting to note that such a great increase in distance (1000 to 5000 miles or a ratio of 5 to 1) affects the limit of loop submergence in the ratio of 40 to 25 feet, or only about 1.6 to 1. This is an indication of how restricted underwater reception is with regard to depth below the surface for tolerable performance.

THE BOUNDARIES OF UNDERWATER RECEPTION

Figure 8 shows how in a practical case computed loop depth for a constant-output signal-to-noise ratio varies with distance. The transmitter is assumed to provide a radiated power of 160 kilowatts for both the 20- and the 150-kc cases. The 20-kc curve is based on measured characteristics for a 21-inch-diameter underwater transformer-coupled loop system, made by RCA, as used with the Navy Model RAK receiver. The 150-kc curve is for the same loop diameter and system Q as the one for 20 kc, but is based entirely on computations.

The zero-decibel output signal-to-noise ratio curves of Figure 8 define limits resembling boundary strata or layers under the sea surface, below which effective reception is, in general, not practicable. Submerged reception is thus somewhat like reception in a duct, with the very-low-frequency signals providing deepest and longest duct operation. With the loop submerged 35 feet, signals can theoretically be read to about 2300 miles from the transmitter under optimum conditions at 20 kc, but only to about 50 miles at 150 kc. With the loop at 20 feet depth, reception at 20 kc may reach an optimum range of 8000 miles, while at 150 kc the range may be as much as 1100 miles. Location of the loop relatively near the surface of the water is a "must" for underwater reception.

DIRECTIONAL RECEPTION WITH UNDERWATER LOOPS

A loop antenna rotated about its vertical axis under water will exhibit the same directional effect as it provides during operation above the surface. As the loop turns from its

maximum pickup position, in which the plane of the loop winding is parallel to the horizontal electric vector of the downward-advancing wavefront (Figure 9), its terminal voltage follows a cosine law. When the plane of the winding reaches a 90-degree angle relative to the electric vector, the loop terminal voltage becomes zero. At this position there is no voltage induced in any part of the winding. This same effect can be obtained with a loop in air by rotating the loop about a horizontal axis instead of the vertical axis normally utilized with the usual vertically polarized air wave. The directional characteristic of an air loop as usually employed, however, depends on difference in time of arrival of a wavefront at opposite legs of the winding, and not on relative alignment of the loop winding plane and the plane of polarization of the oncoming wave. Shielding of an underwater loop is normally unnecessary even when directional reception is desired, since in this case the Figure-8 pattern is the result of relative alignment between the plane of the loop and the plane of wave polarization.

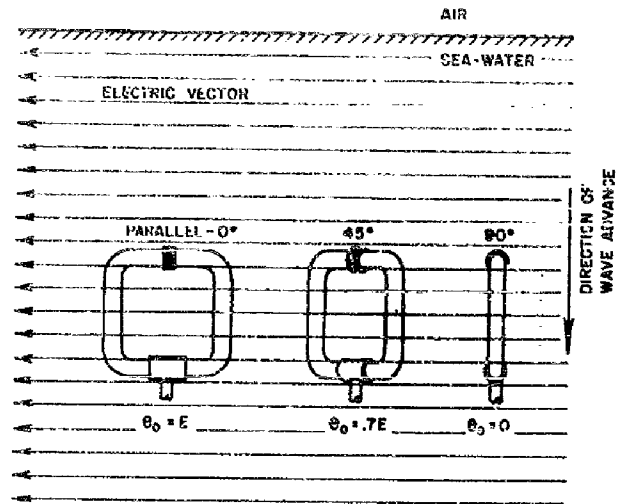

Figure 9 - Effect on terminal voltage of rotating an underwater loop about its vertical axis

Figure 10 shows the directional effects observed in 1940 with a loop system installed on U.S. Submarine S-30. Pattern discrepancies for the submerged condition are largely the result of difficulties in maintaining a constant depth while orienting the fixed loop by turning the submarine.

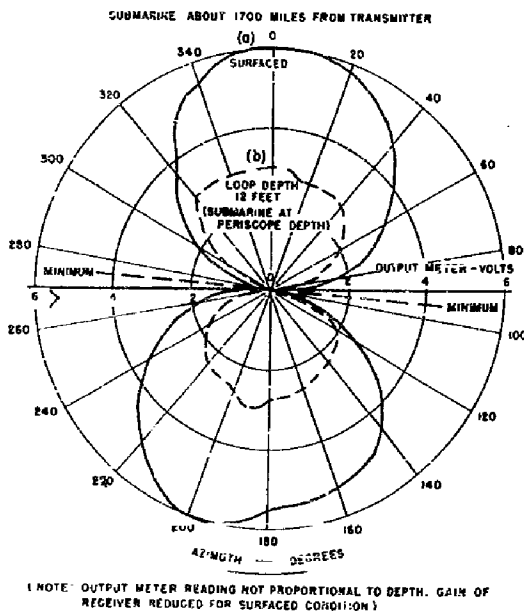

Figure 10 - Measured directional patterns of a loop (a) in air and (b) in sea water

NONDIRECTIONAL LOOPS

For communication purposes, and for navigational aids which depend on time of arrival of two transmitted waves (hyperbolic navigation), the directional receiving characteristics of loop antennas are generally undesirable. It is possible to combine the pickup patterns of two loops so as to provide omnidirectional reception, but only, however, if the phase of the terminal voltage of one loop is shifted by 90 degrees prior to being added to the other.

Figure 11a shows a schematic diagram of a pair of identical crossed loops in isometric view. The arrows indicate relative angles of arrival of a radio wave. The crossed

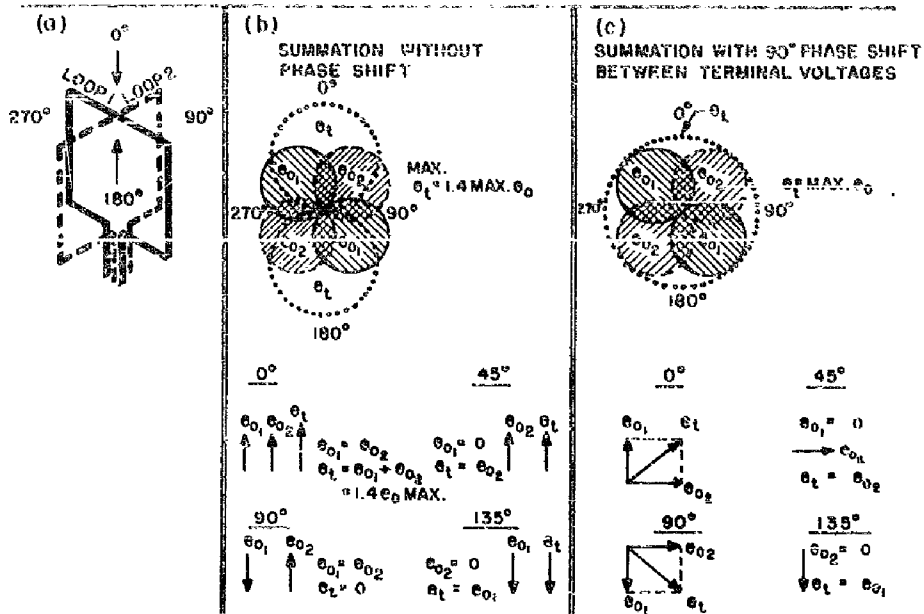
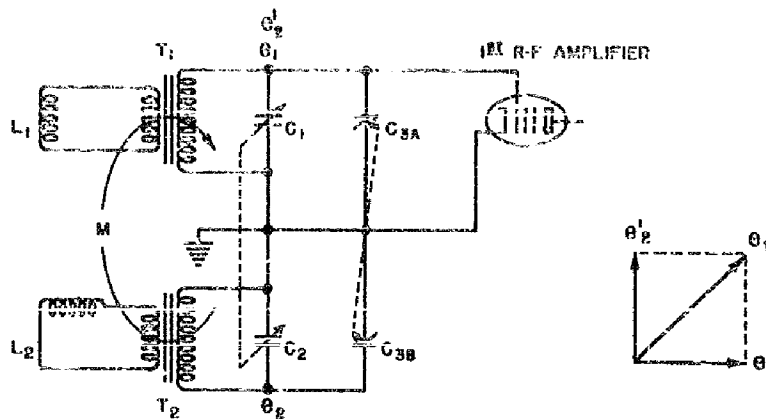

Figure 11 - Field patterns of crossed loops

figure-eight patterns of the two loops result in a summation pattern which is also a figure-eight, but with its minima located at 45 degrees relative to those of either loop, as illustrated in Figure 11b. This is the case for no shift in phase between the two loop terminal voltages, e_{01} and e_{02} . Adding the two loop voltages with an electrical phase shift of 90 degrees between them produces a circular summation pattern, as shown in Figure 11c. This is of the nondirectional form normally desirable for underwater communications reception. The maximum possible loop system terminal voltage obtainable in this way will have a value equal to the voltage obtained from either loop alone at its maximum response orientation.

When the planes of the loops are vertical, the antenna pattern will be circular for vertically polarized waves advancing horizontally and horizontally polarized waves advancing vertically. The response will have a circular null for horizontally polarized waves advancing horizontally. Consequently, tilting of the loops from a vertical plane in air will result in reduced response from a vertically polarized wave advancing horizontally. With 45-degree tilt of the loop structure, for instance, pickup will be reduced 3 decibels. In underwater operation a figure-eight pattern will be obtained when the common axis of the loops is horizontal instead of the normal vertical. Such positioning of the loops, however, is practically never encountered in actual use, since it would require that the loop structure tilt 90 degrees from its normal position.

The 90-degree phase difference between the two loop terminal voltages can be obtained with rather simple circuitry, such as shown in Figure 12. In this circuit the 90-degree phase shift and the proper matching of amplitudes is inherently automatic. Considerable departure from the 90-degree phase angle due to mistuning of either transformer can be tolerated; such departures will produce mainly deviation from the perfectly circular theoretical pattern. A phase difference of about 45 degrees instead of 90, for instance, would result in 3 decibels loss in output-voltage level at the orientation of least crossed-loop response. This circuit will introduce a loss of approximately 3 decibels in signal-to-noise ratio due to the coupled tuned-circuit configuration, as compared to the output of a single loop at maximum response.



- L_1 AND L_2 = IDENTICAL LOOPS AT RIGHT ANGLES.
 T_1 AND T_2 = IDENTICAL COUPLING TRANSFORMERS.
 C_1 AND C_2 = GANGED SECONDARY TUNING CONDENSERS.
 C_{3A}, C_{3B} = DIFFERENTIAL TRIMMER CONDENSER.
 M = "CRITICAL" MUTUAL COUPLING BETWEEN LOOP SYSTEMS
 (MAY BE CAPACITIVE, INDUCTIVE, OR COMBINED).
 θ_1 AND θ_2 = SECONDARY VOLTAGES OF LOOP SYSTEMS 1 AND 2.
 θ_2 = SYSTEM 2 VOLTAGE APPEARING ACROSS
 SYSTEM 1 SECONDARY.
 θ_1 = VOLTAGE APPLIED TO GRID OF AMPLIFIER TUBE.

Figure 12 - Omnidirectional loop system

CROSSED-LOOP STRUCTURES

A crossed-loop system can consist of two identical loops separately mounted at right angles to each other. It is desirable, however, from the viewpoint of performance and minimum space requirements, to mount the loops coaxially and intermeshed. This type of construction is illustrated in Figure 13a. The iron core appearing in the diagram improves the loop pickup, as discussed in the following sections.

Some of the difficulties involved in the type of construction shown in Figure 13a may be avoided by the four-winding spaced type shown in Figure 13b. Although a simpler construction from the assembly viewpoint, this latter type may have somewhat less pickup for a given volume occupied by the structure.

EFFECT OF IRON CORE ON LOOP EFFICIENCY

Incorporation of a suitable iron-dust or ferrite core in a loop structure can produce an increase of voltage induced in the windings of the loop by a radio wave. The improvement can be considered as resulting from distortion and concentration of the radio field caused by the presence of the iron. The magnitude of improvement in terms of over-all receiving system sensitivity is shown for a particular case in Figure 14. With a core length of 3.5 inches, for instance, which corresponds to a core-length-to-diameter ratio of 1.55, the iron-cored loop has 4 decibels more pickup (and consequently provides 4 decibels greater sensitivity) than an air-cored loop of the same inductance, Q , and shape factor.

Considerably greater improvement in performance can be realized by proper iron-core and coil design. The curve of Figure 14 does not represent the optimum possible but only indicates the advantage achieved with one simple solenoid-type of structure. The improvement due to the use of iron is retained in underwater operation.

EFFECT OF LOOP DIAMETER ON PICKUP

The magnitude of the voltage induced in a loop, both in air and under water, is dependent on loop-winding enclosed area. For any given constant ratio of coil length to equivalent diameter and with a constant value of inductance, the pickup or induced voltage of the loop will be approximately a direct function of the diameter. Thus, doubling the diameter of the usual type of loop while maintaining the inductance, Q , and the coil-length-to-diameter ratio constant will produce about 6 decibels improvement in receiving system sensitivity. It should be noted, however, that a two-fold increase in diameter with a constant length-to-diameter ratio results in an eight-fold increase in loop displacement or volume.

EFFECT OF DECREASING SUBMERGENCE ON LOOP DIMENSIONS

The induced voltage of a submerged loop may be doubled simply by moving it closer to the surface of the water. At 20 kilocycles, moving the loop center 4 feet closer to the surface will nearly double the underwater field strength and the pickup voltage of the loop. Likewise, the loop diameter may be reduced to almost one-half if the loop center is moved 4 feet nearer to the surface, with no change in loop terminal voltage for a constant value of inductance. Figure 15 indicates for a frequency of 20 kilocycles the reduction in diameter and volume of a loop possible for any given constant values of loop pickup voltage, Q , and inductance as the loop is moved toward the surface. The curves are based on a mean coil-length-to-diameter ratio such that the induced voltage varies with the diameter to the 1.2 power ($D^{1.2}$). The displacement volume of a loop under these conditions can be reduced to as little as one-hundredth of the original value for a change of only 11 feet less submergence.

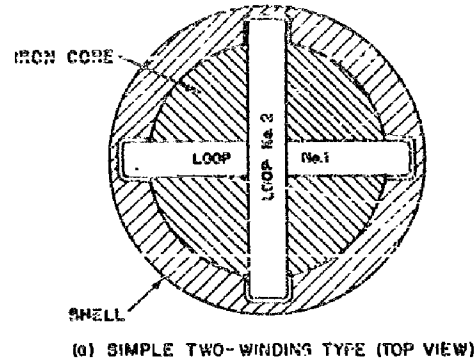

(a) SIMPLE TWO-WINDING TYPE (TOP VIEW)

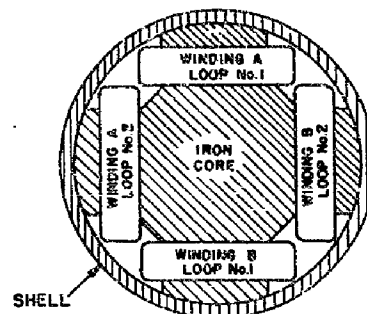

(b) FOUR-WINDING SPACED TYPE (TOP VIEW)
(WINDINGS A AND B IN SERIES FOR EACH LOOP)

Figure 13 - Crossed-loop structures

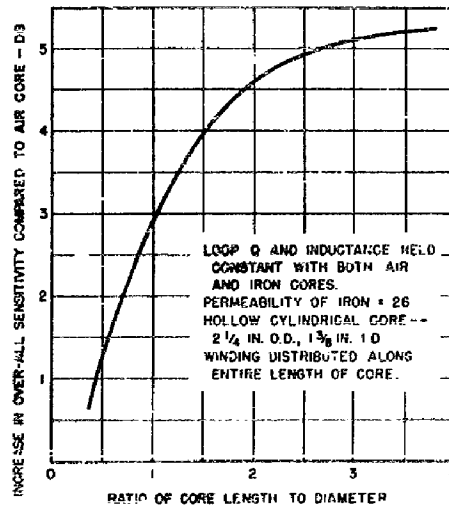

Figure 14 - Measured effect of iron-dust core on loop efficiency

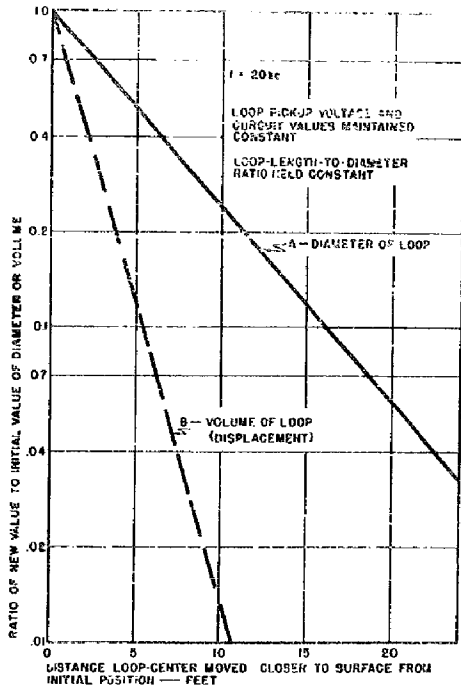

Figure 15 - Computed decrease in loop dimensions possible by moving loop center closer to surface of water

EFFECT OF LOOP CIRCUIT Q ON RECEIVING SYSTEM SENSITIVITY AND BANDWIDTH

Increasing the over-all or net Q of the loop circuit—which would include any cables, transformers, and coupling circuits associated with the loop—will result in an increase in receiving system sensitivity. The magnitude of the increase will depend on whether the bandwidth of the loop circuit is greater or less than the receiver pre-detector bandwidth following the loop. This is shown by curves A and B in Figure 16. The normal case will be between the two curves, so that the improvement in sensitivity, due to doubling the Q, for instance, will be between 3 and 6 decibels.

Increasing the loop circuit Q will also affect the over-all predetector bandwidth of the receiving system to the extent indicated in Figure 17. If the loop bandwidth is much greater than that of the other receiver predetector circuits, changing the loop Q will not substantially change the receiving system bandwidth over-all, as shown by curve A. When loop system bandwidth is much less than that of the other circuits, it affects the 3-decibel bandwidth over-all as shown by curve B.

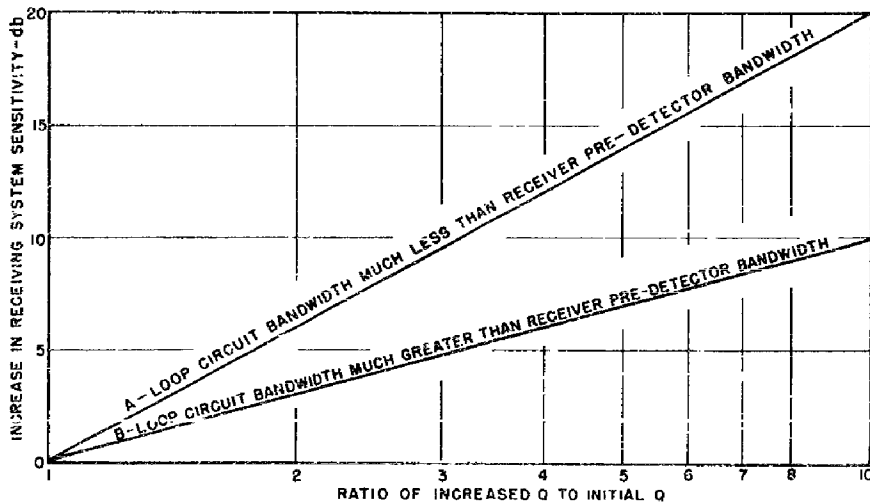

Figure 16 - Computed effect of increase in loop system Q on receiving system sensitivity

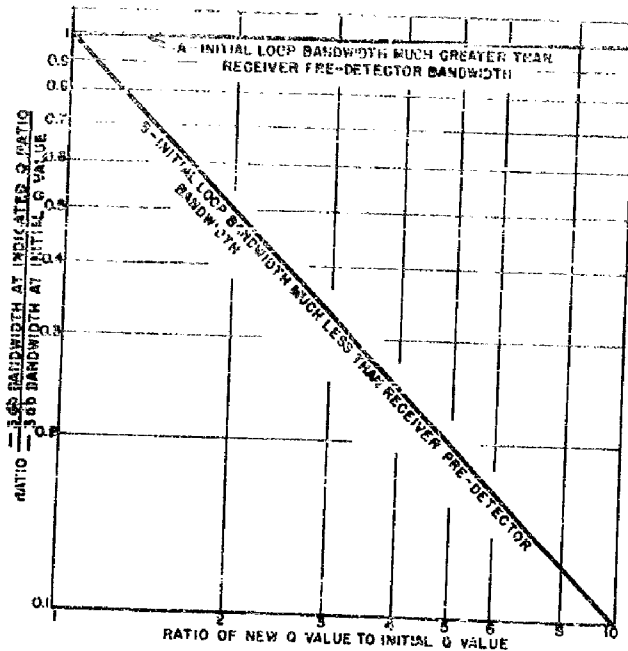

Figure 17 - Computed effect of increase in loop system Q on -3 db bandwidth of receiving system over-all

INCREASE IN LOOP SYSTEM Q EQUIVALENT TO DECREASE OF LOOP SUBMERGENCE

The increase in receiving system sensitivity resulting from an increase in loop system Q is generally equivalent to a rather small decrease in depth of submergence of the loop. This is shown in Figure 18 for 20 kilocycles. It is usually very difficult to double the Q value of most underwater loop systems, even with radical changes in design. Figure 18 shows that the improvement resulting from such a doubling of Q value could be equalled merely by raising the loop center 3 feet closer to the sea surface. A ten-fold improvement in Q is equivalent to only 10 feet decrease in submergence.

SUGGESTED UNDERWATER LOOP COLLECTOR SYSTEM

Figure 19 illustrates a loop system for underwater reception designed to take maximum advantage of the phenomena and limitations already outlined. The loop assembly might be suitably stabilized with fins and would be supported on or suspended from a submerged, hydrostatically controlled buoy at a depth well within the +20-decibel output signal-to-noise ratio boundary

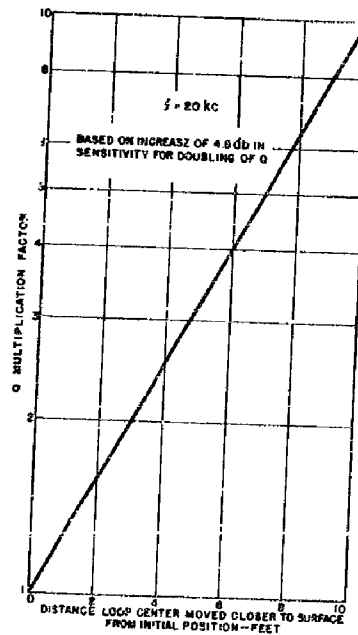

Figure 18 - Computed increase in loop system Q equivalent to decrease of loop submergence

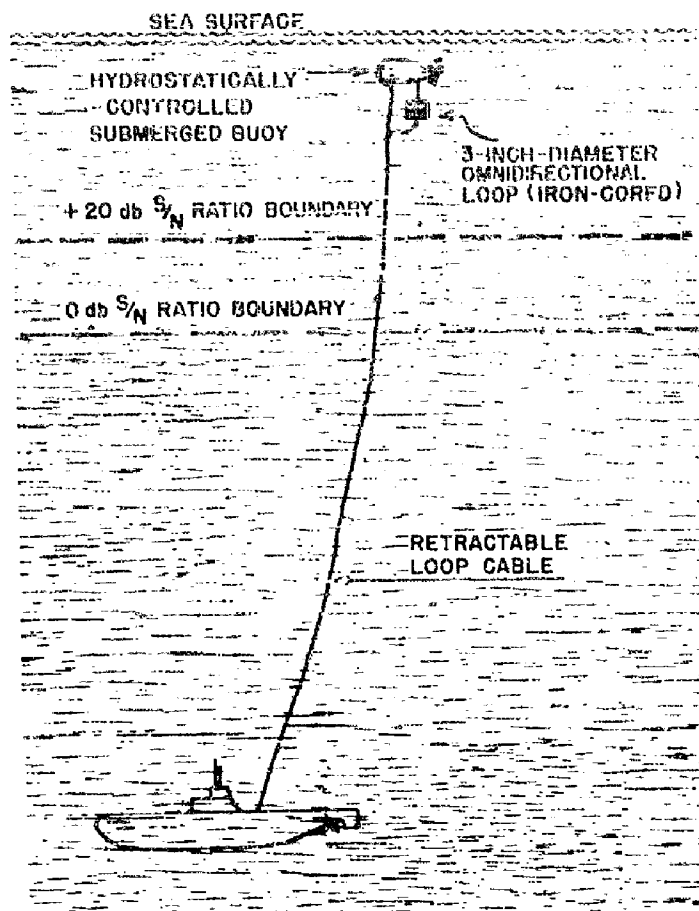

Figure 19 - Suggested underwater loop collector system

for the system (for instance, at 10 feet below the surface). Loop diameter would be on the order of perhaps 3 or 4 inches, and a suitable iron core could be used to produce a loop efficiency approaching that of a 10-inch-diameter air-cored structure. The system would be omnidirectional in two planes, so that normal underwater reception would be essentially unaffected by loop tilts or orientation as usually encountered. The loop structure would be completely enclosed, so that no water would appear in the concentrated field region of the loop windings, permitting good loop Q values to be realized. The loop inductance value would be chosen for best operation with the type of retractable loop cable used.

With a suitable cable, this arrangement should permit excellent reception of VLF signals by deeply submerged submarines. In considering this and other possible schemes, it should be remembered that 2 feet of decreased submergence of the loop at 20 kc is equivalent to almost doubling the radiated power of the transmitter, insofar as the signal is concerned. When atmospheric or other noises mask the signal however, there is, of course, no substitute for increased transmitter power.

CONCLUSIONS

From the foregoing considerations, it is concluded that

- (a) Long-distance underwater reception of radio signals (1000 to about 5000 miles) is largely confined to the VLF range (15 to 30 kc) and to a shallow layer extending not much over 20 feet below the surface.
- (b) A useful underwater communications receiving system is possible only if the receiving antenna is essentially omnidirectional and is always located within the practicable receiving layer, regardless of the depth of submergence of the submarine and of the surface motion of the water.
- (c) Small iron-cored omnidirectional loops suspended near the surface from submerged buoys would permit VLF reception of several thousand miles and may allow reception in the LF range (from 30 to about 100 kc) at distances from a few hundred to possibly 1000 miles.

RECOMMENDATIONS

It is recommended that the loop receiving system herein proposed be considered for further development.

ACKNOWLEDGMENT

The underwater reception theory utilized in this report is based on the work of Dr. O. Norgorden of the Communications Branch of Radio Division II.

* * *

BIBLIOGRAPHY

1. Morecroft, J. H., "Principles of Radio Communication," (2nd Edition) pp. 841-845, Underwater Antennae; New York, Wiley, 1927
2. Morgorden, O., "The Submerged Reception of Radio Frequency Signals," NRL Report R-1669, 2 December 1940
3. Isely, F. C., "Test of Underwater Reception of Low Frequency Radio Signals," NRL Report R-1717 (Confidential), 1 April 1941
4. "Instructions for Installation, Operation, and Maintenance of Type CN-24111 Loop Switching Adapter, Type CN-50085 Loop Switching Unit, and Type CN-62034 Interconnecting Cable (Adapter for VLF Underwater Reception with the Model DQ Loop Antenna and the Model RAK Receiver)," A Edition, RA 50A 257 A, Published by BuShips, 23 February 1942
5. Bureau of Ships Radio and Sound Bulletin No. 6, 1 April 1942
6. NRL letter report C-SS/7(358), C-350-176/45, "Loop Locations for Submerged Reception on USS Conger (SS477)," 2 May 1945
7. NRL letter report C-SS/7(358), C-350-249/45, "Enemy Equipment for Submerged VLF Reception," 23 July 1945
8. NRL letter report C-SS/7(1223:SVF), C-1220-38/46, "Modification and Development of Model RAK Receiver Loop Transformer," 11 March 1946
9. Fratianni, S. V., "Submerged VLF Reception - A Study of Various Loop Coupling Methods," NRL Report R-2872 (Restricted), 31 December 1946
10. NRL letter report R-1220-12/47, "Discussion of Contract for Molded Loop Development," 25 February 1947
11. NRL letter report R-1220-19/48, "Revision of Loop Input Transformer Drawings," 28 January 1948
12. NRL letter report R-1220-30/48, "Modification of a Q-Meter for Testing of Model RAK Receiver Loop-Transformer," 18 February 1948
13. Fratianni, S. V., "Theory and Design of Resonant Transformer-Coupled Loop-Antenna Input Systems for VLF Reception," NRL Report R-3281 (Restricted), 28 April 1948
14. NRL letter report R-3920-209/48, "Revised Report on Model RAK Receiver Type CNM 66097 Loop Coupling Transformer Kit," 24 November 1948
15. Fratianni, S. V., "The Equivalent Selectivity of Transformer-Coupled Loop-Antenna Input Circuits," NRL Report R-3464 (Restricted), 13 May 1948
16. NRL letter report C-3920-67A/49, "Discussion of General Considerations for Underwater Loop Antennas," 26 July 1949

CONFIDENTIAL

APPENDIX

Variations in VLF Signal Strength Due to Simultaneous Reception of Ground and Sky Waves

In addition to propagation as a ground wave (direct ray), which becomes considerably attenuated beyond about 1000 miles (see Figure 6), VLF signals are propagated around the world in "hops" by reflections between the ionosphere and the earth's surface (reflected rays). It may not generally be realized that, at points where the direct and first reflected rays coincide, VLF reception may be quite poor. This condition will be particularly evident when the phase of the reflected carrier is about 180 degrees opposed to that of the direct wave because of difference in path lengths and the intervention of the reflecting surfaces.

Similar but progressively less marked deterioration of signal strength will also occur at coincidence of the ground wave with the sky waves on the second and succeeding hops. Regions of poor reception may therefore be encountered from about 300 to 500 nautical miles from the transmitters, with occasional deterioration of signal up to perhaps 1000 miles. Whenever a sunset zone intervenes between transmitter and receiver, there will be reduction in signal strength as compared to a path which is entirely in day or night.

Fluctuations in the height and composition of the ionosphere with changes in time of day, season, and solar activity will result in changing signal conditions at the receiving location. Complete loss of signal should seldom be encountered, the most likely region being at the first-hop range. The reduction in field strength as the receiving antenna is submerged, however, will make the zones of interference between the sky and ground waves much more evident. Under these conditions, increase in distance from the transmitter may produce the anomalous result of increasing signal strength as the submarine traverses the interference zone at any given practicable depth of submergence. In general, VLF carriers will provide good communications, particularly for long-distance operations.

* * *

CONFIDENTIAL

NOTE ON RECEIVER CIRCUITRY FOR VLF UNDERWATER RECEPTION

In general, receiver designs for VLF submerged reception are similar to those intended for ordinary VLF radio use. Some special considerations will, however, apply.

The superheterodyne type of receiving system will normally be more desirable than the TRF (tuned-radio-frequency) type for this frequency range (15 to 30 kilocycles). The disadvantages of the superheterodyne, i.e., increased number of spurious responses, and conversion oscillator tracking and stability problems, will be outweighed by the advantages of better selectivity, more uniform gain over the frequency range, and the greater ease of adding auxiliary circuits such as noise limiters. Superheterodyne selectivity is closer to the ideal of a rectangular or trapezoidal characteristic (relatively wide "nose," relatively narrow "skirt").

The use of tuned-coupled-circuit networks at the receiver input and for interstage loading throughout will be advantageous, both for selectivity purposes and for minimizing transient disturbances, such as atmospheric and man-made static. A pair of tuned circuits at or near critical coupling will in any case be needed if the omnidirectional loop system shown in this report is used. Switching should then be provided to permit the use of only one loop winding when desired. Receiver pre-detector bandwidth (r-f + i-f) must be wide enough to allow passage of the keying-modulation sidebands to a degree sufficient for easy reading of Morse code characters at the highest keying speeds likely to be encountered, without, however, excessive compromise in the ability to separate adjacent-channel signals. Provision of variable predetection bandwidth control (i-f) should be seriously considered. The beating oscillator (audio-beat oscillator) at the final detector should be arranged for switching either above or below the i-f center frequency, to assist in avoidance of simultaneous beating of two adjacent-channel signals. The oscillator-injected voltage should be controllable if a noise limiter is used.

Location of preselector circuits and tubes in the loop housing appears at first sight to be an attractive device for avoiding the losses in signal-to-noise ratio imposed by loop cables and transformers. It is, however, very desirable to use low-impedance loops in order to minimize the shunt resistance losses due to moisture and water leakage in the loop system. The very high impedance of direct-tuned loops is under these conditions obviously a hazard which can result in a loss in efficiency much greater than a loop transformer's insertion loss. In addition, the problems of remote tuning of a resonating condenser in the loop housing and the supply of filament and plate voltages from the submarine to the loop make the idea unattractive.

A good noise-peak limiter can be very helpful in the reception of weak VLF signals through atmospheric noise. The series-diode type with a simple counter-modulation circuit is recommended. Control of the audio-beat oscillator voltage will assist in obtaining best performance with noise-limiter "on" operation.

The audio circuits following the final detector should utilize a low-pass filter cutting off at about 1500 cps. A separately controllable variable-frequency peaked filter will also be advantageous for further audio selectivity. All such filters must have low Q circuits, properly terminated, so that their transient response characteristics will be good enough to avoid obscuration of keying due to "ringing" effects. With good audio circuit design, it will be advantageous to use headphones or loudspeakers with relatively wide frequency response, free of peaks, so as to avoid ringing effects in the acoustic transducer element.

CONFIDENTIAL

CADO CONTROL NO.:	US CLASSIFICATION: CONFIDENTIAL	ATI NO.: 68929	OA NO.: 3605	U PUB 2
TITLE: Underwater Loop Reception Phenomena and Techniques - <i>Corrected Copy (1) 9-8-50</i> <i>and Appendix (NRL Report) - Revised 12 June 1950</i>				
AUTHOR(S): Toth, Emerick, Fratanni, S.V.				
ORIGINATING AGENCY: Office of Naval Research, Naval Research Lab., Washington, D.C.				
FOREIGN TITLES: (N.A.) 5 6 3-1				
PUBLISHED BY: (Same)		PUBLISHING NO.: (Same)		
TRANSLATED BY: (N.A.)		TRANSLATION NO.: (N.A.)		
PREVIOUSLY CATALOGED AS: (N.A.)				

AIR FORCE FORM NO. 64-1 JUL 50 225M

CADO FORM NO. 5C - LIBRARY CARD

~~SEC. Authority: S. G. Miller
1/2/71~~

U Auth: NSNRL ltr, 21 Oct 71

Department Dictation

1/2/71