

UNCLASSIFIED

AD NUMBER

ADA800577

CLASSIFICATION CHANGES

TO: unclassified

FROM: restricted

LIMITATION CHANGES

TO:
Approved for public release; distribution is unlimited.

FROM:
Distribution authorized to DoD only; Administrative/Operational Use; SEP 1945. Other requests shall be referred to National Aeronautics and Space Administration, Washington, DC. Pre-dates formal DoD distribution statements. Treat as DoD only.

AUTHORITY

Index of NACA Technical Publications dtd 31 Dec 1947; NASA TR Server website

THIS PAGE IS UNCLASSIFIED

Reproduction Quality Notice

This document is part of the Air Technical Index [ATI] collection. The ATI collection is over 50 years old and was imaged from roll film. The collection has deteriorated over time and is in poor condition. DTIC has reproduced the best available copy utilizing the most current imaging technology. ATI documents that are partially legible have been included in the DTIC collection due to their historical value.

If you are dissatisfied with this document, please feel free to contact our Directorate of User Services at [703] 767-9066/9068 or DSN 427-9066/9068.

**Do Not Return This Document
To DTIC**

Reproduced by
AIR DOCUMENTS DIVISION

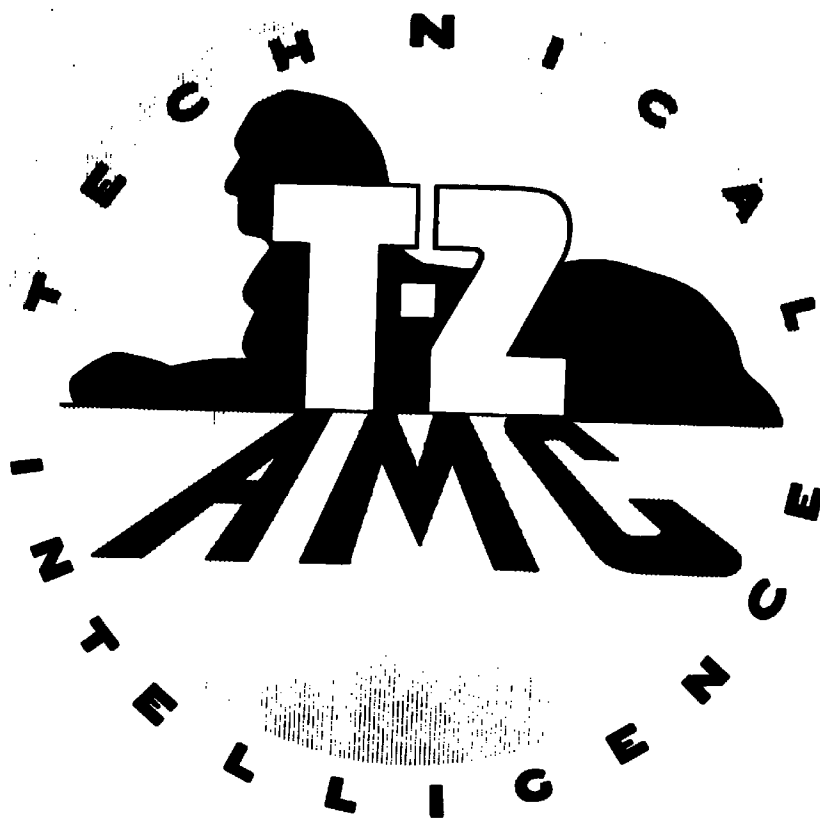

HEADQUARTERS AIR MATERIEL COMMAND

WRIGHT FIELD, DAYTON, OHIO

The
U.S. GOVERNMENT

IS ABSOLVED

FROM ANY LITIGATION WHICH MAY
ENSUE FROM THE CONTRACTORS IN-
FRINGING ON THE FOREIGN PATENT
RIGHTS WHICH MAY BE INVOLVED.

REEL - C

151

A.T.I.

6406

D 52 338 / 670

ARR No. L5G25

RESTRICTED

NATIONAL ADVISORY COMMITTEE FOR AERONAUTICS

ATI No. 6406

WARTIME REPORT

ORIGINALLY ISSUED
September 1945 as
Advance Restricted Report L5G25

WIND-TUNNEL INVESTIGATION OF CONTROL-SURFACE CHARACTERISTICS

XXIII - A 0.25-AIRFOIL-CHORD FLAP WITH TAB HAVING A
CHORD TWICE THE FLAP CHORD ON AN NACA 0009 AIRFOIL

By M. Leroy Spearman

Langley Memorial Aeronautical Laboratory
Langley Field, Va.

OFFERED

MAR 21 1947

FILE COPY

RETURN TO

Special Documents Branch - TSRWf-6
Wright Field Reference Library Section
Air Documents Division - Intelligence (I-2)
Wright Field, Dayton, Ohio

Air Documents Division, I-2
AFC, Wright Field
Memorandum

R C-151 F 6406

NACA

WASHINGTON

NACA WARTIME REPORTS are reprints of papers originally issued to provide rapid distribution of advance research results to an authorized group requiring them for the war effort. They were previously held under a security status but are now unclassified. Some of these reports were not technically edited. All have been reproduced without change in order to expedite general distribution.

NACA ART No. L5G25

NATIONAL ADVISORY COMMITTEE FOR AERONAUTICS

ADVANCE RESTRICTED REPORT

WIND-TUNNEL INVESTIGATION OF CONTROL-SURFACE CHARACTERISTICS

XXIII - A 0.25-AIRFOIL-CHORD FLAP WITH TAB HAVING A
CHORD TWICE THE FLAP CHORD ON AN NACA 0009 AIRFOIL

By M. Leroy Spearman

SUMMARY

Wind-tunnel tests have been made to determine the aerodynamic section characteristics of an NACA 0009 airfoil with a plain flap having a chord 25 percent of the airfoil chord and a balancing tab having a chord 50 percent of the airfoil chord or 200 percent of the flap chord so linked that the tab would deflect at a given rate with respect to the flap. Three linkage ratios were tested on the model.

The tests indicated that the flap and tab could be linked to give hinge-moment balance with flap deflection and with angle of attack and yet have greater lift effectiveness than a plain flap of similar size with a conventional balancing tab having a chord 20 percent of the flap chord linked to give hinge-moment balance with flap deflection only.

INTRODUCTION

The problem of closely balancing control surfaces to reduce the hinge moments, and consequently the stick forces, with a minimum loss in lift due to the action of the balancing device is becoming increasingly important. An extensive investigation of control-surface characteristics is being conducted at the Langley Laboratory of the National Advisory Committee for Aeronautics in an attempt to solve this problem. A brief summary of the characteristics of some of the balancing-tab arrangements investigated to date is presented in the following paragraphs.

It is suggested in reference 1 that a control surface overbalanced by a large overhang with a tab deflecting in the same direction as the flap might produce high lift at small deflections. This arrangement was tested in the Langley 7- by 10-foot tunnel on a finite-span tail (reference 2) and the results indicated that satisfactory control-surface characteristics could be obtained over only a small flap-deflection range. The flap deflection was limited by the air-flow separation when the overhang protruded into the air stream.

Previous tests (reference 3) have shown that small-chord plain flaps at high flap deflections can produce as much lift as large-chord balanced flaps at normal deflections. The high deflections of the small-chord flaps gave excessive hinge moments for large airplanes, however, and a small-chord flap combined with a balancing device that would not protrude into the air stream or limit flap deflections therefore appeared to be a possible solution of this problem.

An analysis presented in reference 2 indicated that hinge-moment balance with flap deflection as well as with angle of attack could be obtained by linking two flaps to operate in opposite directions with the chord of the larger flap twice the chord of the smaller flap. With this arrangement the smaller flap would produce the lift and the larger flap, linked to move only slightly, would serve as a balancing tab and trimming surface and would not protrude into the air stream as would an overhang balance. The calculations indicated that this flap arrangement, linked to give complete balance, would have greater lift effectiveness than a plain flap of similar size with a conventional balancing tab having a chord 20 percent of the flap chord. (See table I.) Another advantage of this type of flap arrangement is that the weight of the forward flap might be utilized as a mass balance for the system, and thus the need for additional concentrated weights might be eliminated.

The purpose of the present investigation is to determine the characteristics of a plain flap with a tab having a chord twice the flap chord through a wide range of flap deflection and angle of attack and thus to provide a check on the analysis of reference 2.

COEFFICIENTS AND SYMBOLS

The coefficients and symbols used are defined as follows:

- c_l airfoil section lift coefficient $\left(\frac{l}{qc}\right)$
 c_{hf} flap section hinge-moment coefficient $\left(\frac{hf}{qc_f^2}\right)$
 c_{ht} tab section hinge-moment coefficient $\left(\frac{ht}{qc_t^2}\right)$
 c_h section hinge-moment coefficient of flap and tab combination $\left(\frac{h}{qc_f^2}\right)$

where

- l airfoil section lift
 hf flap section hinge moment about point at distance d from tab hinge axis (fig. 1)
 ht tab section hinge moment about tab hinge axis
 h section hinge moment of flap and tab combination about point at distance d from tab hinge axis (fig. 1)
 c chord of basic airfoil
 c_f flap chord ($0.25c$)
 c_t tab chord ($0.50c$)
 q dynamic pressure
 and
 α_0 angle of attack for airfoil of infinite aspect ratio
 δ_f flap deflection with respect to tab
 δ_t tab deflection with respect to line from tab hinge line to pivot point of flap

- δ_{t_0} tab deflection with respect to airfoil when $\delta_f = 0$
 d distance from hinge line of tab to hinge line of flap
 d' distance from hinge line of tab to pivot point of flap

and

$$c_{l_a} = \left(\frac{dc_l}{da_0} \right)_{\delta_f} \delta_f$$

$$c_{l_b} = \left(\frac{dc_l}{d\delta_f} \right)_{a_0} a_0$$

$$a_b = \left(\frac{da_0}{d\delta_f} \right)_{c_l} c_l$$

$$c_{h_a} = \left(\frac{dc_h}{da_0} \right)_{\delta_f} \delta_f$$

$$c_{h_b} = \left(\frac{dc_h}{d\delta_f} \right)_{a_0} a_0$$

The subscripts outside the parentheses represent the factors held constant during the measurement of the parameters.

APPARATUS AND PROCEDURE

Model

The 2-foot-chord by 4-foot-span model (fig. 1) was tested in the Langley 4- by 6-foot vertical tunnel described in reference 4 and was made of laminated mahogany to the NACA 0009 profile. The model was equipped with a 0.25c flap and a 0.50c or 2.00cf tab. For the gap-open tests the gaps between the airfoil and the tab and between the tab and the flap were 0.005c. The flap and tab were deflected in opposite directions in a manner similar to that for conventional balancing tabs by means of the linkage system shown schematically in figure 1. The model was so arranged that the position of the flap pivot point could be moved upward, which in effect deflected the tab upward 5°, 10°, or 15° (measured in each case when $\delta_f = 0^\circ$) for trimming. The range of flap

deflection available was not affected by changing the position of the flap pivot point.

The flap deflection for any given tab deflection can be obtained analytically for each linkage. If d and d' are as indicated in figure 1,

$$\tan \delta_f = \frac{\sin \delta_t}{-\frac{d}{d'} + \cos \delta_t} \quad (1)$$

and the ratio of tab deflection to flap deflection is

$$\frac{\delta \delta_t}{\delta \delta_f} = \frac{\left(\cos \delta_t - \frac{d}{d'}\right)^2}{\left(1 - \frac{d}{d'} \cos \delta_t\right) \cos^2 \delta_f} \quad (2)$$

Regardless of the linkage system used, the hinge moment of the flap and tab combination will be unchanged provided the value of $\frac{\delta \delta_t}{\delta \delta_f}$ remains unchanged. In order to test different rates of tab deflection, the distance d' was varied. Tab deflection and the ratio of tab deflection to flap deflection, as calculated by equations (1) and (2), are plotted against flap deflection for three linkages in figure 2.

Test Conditions and Equipment

The tests were made at a dynamic pressure of 13 pounds per square foot, which corresponds to a velocity of 71 miles per hour under standard conditions. The effective Reynolds number for maximum lift coefficients for these tests was approximately 2.57×10^6 . (Effective Reynolds number = test Reynolds number \times turbulence factor. The turbulence factor for the Langley 4- by 6-foot vertical tunnel is 1.93.)

The airfoil model when mounted in the tunnel completely spanned the test section. With this type of installation, two-dimensional flow is approximated and section characteristics of the model can be determined.

Tests were made of the configurations indicated in table II. The deflection rates are given for zero flap deflection. Measurements were made of the lift, drag, pitching moment, and flap hinge moment but, since the present investigation is concerned mainly with lift and hinge-moment characteristics, only values of lift and hinge moment are presented.

Corrections

An experimentally determined tunnel correction was applied to the lift. The angle of attack and hinge moments were corrected for the effect of streamline curvature induced by the tunnel walls in accordance with a theoretical analysis similar to that presented in reference 5 for finite-span models.

The tunnel-wall corrections were applied in the following manner:

$$\begin{aligned} \alpha_o &= \alpha_{oT} + (0.21c_{lT} - 0.156c_{lTf}) \\ c_l &= (0.965 - |0.007c_{lT}|) c_{lT} \\ c_h &= c_{hT} + 0.1052F c_{lTf} \end{aligned}$$

where

α_{oT} measured angle of attack

c_{lT} measured lift coefficient

c_{lTf} measured lift coefficient caused by flap deflection (measured arbitrarily at $\alpha_{oT} = -3^\circ$)

c_{hT} measured hinge-moment coefficient

and F is a constant that is a function of each linkage arrangement and is given in the following table:

$\delta\delta_t/\delta\delta_f$	F
-0.10	-0.0323
-0.15	-.0094
-0.20	.0056

DISCUSSION AND RESULTS

Theory

The following analysis was originally presented in reference 2 but is repeated here, in slightly different form, for clarity.

In selecting the optimum size of balancing surface to use in connection with a flap, the lift as well as the hinge moments of the balancing surface and the flap must be considered. It is shown in reference 2 that the greatest lift effectiveness is obtained from a 0.25c flap with a 0.50c tab. Reference 2 indicates also that, with this arrangement, the hinge-moment parameters could be made almost zero.

The following general relations can be shown to hold for any two flaps hinged in series where the subscripts t and f are used for the forward and rearward flaps, respectively:

$$\frac{da_o}{d\delta_f} = \frac{\partial a_o}{\partial \delta_f} + \frac{\partial a_o}{\partial \delta_t} \frac{\partial \delta_t}{\partial \delta_f} \quad (3)$$

$$\frac{dch}{da_o} = \frac{\partial ch_f}{\partial a_o} + \frac{\partial ch_t}{\partial a_o} \left(\frac{ct}{cf}\right)^2 \frac{\partial \delta_t}{\partial \delta_f} \quad (4)$$

$$\frac{dch}{d\delta_f} = \frac{\partial ch_f}{\partial \delta_f} + \left(\frac{ct}{cf}\right)^2 \frac{\partial \delta_t}{\partial \delta_f} \left(\frac{\partial ch_t}{\partial \delta_t} \frac{\partial \delta_t}{\partial \delta_f} + \frac{\partial ch_t}{\partial \delta_f} \right) + \frac{\partial ch_f}{\partial \delta_t} \frac{\partial \delta_t}{\partial \delta_f} \quad (5)$$

The solution for $\frac{\partial \delta_t}{\partial \delta_f}$ from equation (5) that results in $\frac{dch}{d\delta_f} = 0$ yields two roots. This result indicates that there are two values of ratio of tab deflection to flap deflection which will give $\frac{dch}{d\delta_f} = 0$. One root gives a negative value of a_g , which corresponds to the arrangement tested; the other root gives a positive a_g , which indicates that the lift comes from the forward flap and the balance from the rear flap as is the case with a conventional balancing tab. (For the arrangement tested, the normal tab and flap positions are reversed.)

The results obtained with equations (3) and (4) are presented in figure 3 for various values of the tab-to-flap linkage ratio. The hinge-moment data as presented in reference 2 were not corrected for the effect of streamline curvature resulting from the jet boundaries. This streamline-curvature correction was applied to the data of reference 2, however, for the computed curves in figure 3. The ratio $\frac{c_{st}}{c_{sr}}$ was varied from 0 to -0.25 in order to compute the aerodynamic characteristics presented in figure 3. On the model tested, the ratio $\frac{\delta b_t}{\delta b_r} = -0.10$, -0.15, and -0.20 were used to ensure that the ratio at which ch_a and ch_b become zero could be found.

Test Results

Lift.— The lift characteristics are presented in figures 4 to 7 for 0.005c gaps and figures 8 to 11 for sealed gaps. The lift parameters are given in table III and are plotted against linkage ratio in figure 12. The parameters were measured at $c_l = 0$ since deflecting the tab for trimming shifted the curves so that the linear range of coefficients occurred at a higher angle of attack.

For all tab trim positions the rate of change of lift coefficient with flap deflection $c_{l\delta}$ increased as the linkage ratio decreased. As would be expected, the slope of the lift curve $c_{l\alpha}$ remained almost unchanged and consequently the lift effectiveness of the flap a_δ increased as the linkage ratio decreased. The flap was fairly effective up to deflections of about 20° and the effectiveness at larger deflections was improved as the linkage ratio decreased. Sealing the gaps increased $c_{l\alpha}$, $c_{l\delta}$, and a_δ .

Deflecting the tab for trimming had no effect on $c_{l\alpha}$, $c_{l\delta}$, or a_δ , but the lift curves became increasingly nonlinear in the negative lift range as the tab was deflected more negatively. This effect is the result of air-flow separation that is probably caused by the break in the airfoil contour at the 0.50c station, which results from deflecting the tab. The same effect on the lift curves can be seen as the camber increases for airfoils having maximum camber at the 0.50c point (reference 6).

Moving the tab trim position negatively shifted the lift curves so that greater negative lift, which is desired for a horizontal tail near the ground, could be

obtained in the landing attitude. This method of trimming is about 75 percent as effective as an adjustable stabilizer. With the tab deflected approximately -10° or more the elevator control through the deflection range tested is insufficient for obtaining zero lift for the horizontal tail, unless the surface is at a positive angle of attack (as when near the ground). This effect would be important in the case of a wave-off condition, since the tab trim position would probably be changed by a fairly slow mechanical method and the pilot might not have adequate elevator control.

The characteristics for a 0.20c_f conventional balancing tab were computed from equations (3), (4), and (5) and are compared with the characteristics predicted for the 2.00c_f balancing tab in table I. As predicted by the analysis, q_0 for the 2.00c_f balancing tab is about 25 percent greater than for the 0.20c_f conventional balancing tab linked to give hinge-moment balance with flap deflection only.

Hinge moments.—Hinge-moment characteristics are presented in figures 4 to 7 for 0.005c gaps and figures 8 to 11 for sealed gaps. A list of hinge-moment parameters is given in table III and the variation of hinge-moment parameters with linkage ratio is shown in figure 12 for each tab trim deflection with the gaps open and sealed. The variation of hinge-moment coefficient with lift coefficient for various angles of attack at two tab trim settings and two ratios of tab deflection to flap deflection with the 0.005c gaps and the sealed gaps is shown in figure 13.

The hinge-moment curves differ from the usual hinge-moment curve in that ch_g becomes more nearly zero (and in some cases even positive) with the flap deflected than with the flap neutral. The values of ch_g tended to become more negative as the linkage ratio $\delta\delta_t/\delta\delta_f$ approached zero. Nearly complete balance was generally obtained at a ratio of tab deflection to flap deflection of -0.15, which is in agreement with the analysis presented in reference 2 and with the results shown herein in figure 3.

The decrease in ch_g as the linkage ratio approaches zero is to be expected because the amount of balancing moment contributed to the flap by the tab is reduced as

the pivot point (fixed relative to main airfoil) of the flap moves forward. For each linkage ratio the hinge moment caused by flap deflection becomes more negative rapidly at deflections of about 10° for the 0.005c gaps and about 15° for the sealed gaps. This effect is probably caused by air-flow separation over the flap, as has been generally observed on other airfoils having highly balanced flaps. For a linkage ratio of -0.15 with the tab trimmed at zero, the hinge moments are very closely balanced for deflections up to about 10° or 15° throughout the angle-of-attack range.

The value of ch_a becomes more negative as the linkage ratio decreases. This effect is the result of the decrease in balancing moment produced on the flap by the tab and also of the decrease in the amount of flap area ahead of the fixed pivot point. The balancing moments decrease as the pivot point of the flap moves forward and the effect is similar to that of decreasing the size of an overhang balance.

Deflecting the tab for trimming had little effect on ch_a and ch_b measured at the angle of zero lift. As the tab is deflected negatively, however, the hinge moments become more closely balanced at higher positive angles of attack. With this arrangement, higher lifts at large angles of attack could be obtained with less hinge moment than could be obtained with the tab trimmed at zero. Such a variation is desirable for landing when the present system is used as an elevator, or for trimming the yawing moment due to slipstream rotation when it is used as a rudder on single-engine airplanes if the rudder deflection and angle of attack are of opposite sign.

Sealing the gaps (fig. 12) generally gives a more positive value of ch_b for initial tab trim deflections of both 0° and -15° . The effect on ch_a of sealing the gaps was not consistent, however, since the increment was negative for $\delta t_0 = 0^\circ$ and positive for $\delta t_0 = -15^\circ$.

CONCLUSIONS

Tests were made of an NACA 0009 airfoil with a flap having a chord 25 percent of the airfoil chord (0.25c)

and a tab having a chord 200 percent of the flap chord (2.00c_f). The following conclusions were indicated:

1. A flap with a 2.00c_f balancing tab could produce hinge-moment balance with both angle of attack and flap deflection and yet have greater lift effectiveness than a flap of similar size equipped with a 0.20c_f conventional balancing tab linked to give hinge-moment balance with flap deflection only.

2. Deflecting the tab for trimming was about 75 percent as effective as an adjustable stabilizer.

3. The most nearly complete balance was obtained at a ratio of tab deflection to flap deflection equal to -0.15, as had been indicated by a previously published analysis.

4. Setting both gaps generally increased the slope of the lift curve $c_{l\alpha}$ and the lift effectiveness of the flap u_0 and gave more positive values for the rate of change of hinge-moment coefficient with flap deflection ch_δ .

5. With the tab deflected negatively for trim, the hinge moments were closely balanced at high positive angles of attack, which is desirable for the landing condition.

Langley Memorial Aeronautical Laboratory
National Advisory Committee for Aeronautics
Langley Field, Va.

REFERENCES

1. Sears, Richard I., and Hoggard, H. Page, Jr.: Wind-Tunnel Investigation of Control-Surface Characteristics. II - A Large Aerodynamic Balance of Various Nose Shapes with a 30-Percent-Chord Flap on an NACA 0009 Airfoil. NACA ARR, Aug. 1941.
2. Sears, Richard I.: Wind-Tunnel Data on the Aerodynamic Characteristics of Airplane Control Surfaces. NACA ACR No. 3L03, 1943.
3. Sears, Richard I., and Purser, Paul E.: Wind-Tunnel Investigation of Control-Surface Characteristics. XIV - NACA 0009 Airfoil with a 20-Percent-Chord Double Plain Flap. NACA ARR No. 3F29, 1943.
4. Wenzinger, Carl J., and Harris, Thomas A.: The Vertical Wind Tunnel of the National Advisory Committee for Aeronautics. NACA Rep. No. 307, 1931.
5. Swanson, Robert S., and Toll, Thomas A.: Jet-Boundary Corrections for Reflection-Plane Models in Rectangular Wind Tunnels. NACA ARR No. 3E22, 1943.
6. Jacobs, Eastman W., Ward, Kenneth E., and Pinkerton, Robert M.: The Characteristics of 73 Related Airfoil Sections from Tests in the Variable-Density Wind Tunnel. NACA Rep. No. 460, 1933.

TABLE I
 COMPUTED CHARACTERISTICS OF A 0.25c FLAP WITH
 A 2.00c_f AND A 0.20c_f TAB

c_t/c_f	$\delta\delta_t/\delta\delta_f$	a_δ	ch_a	ch_s
0.20	-0.93	-0.33	-0.0063	0
2.00	-.16	-.40	.0001	0

TABLE II
 TAB TRIM POSITIONS AND DEFLECTION RATES TESTED

δt_0 (deg)	$\delta\delta_t/\delta\delta_f$	Gaps	Figure	
0	-0.10	Open	4(a)	
0	-.15		↓(b)	
0	-.20		↓(c)	
-5	-.10		5(a)	
-5	-.15		↓(b)	
-5	-.20		↓(c)	
-10	-.10		6(a)	
-10	-.15		↓(b)	
-10	-.20		↓(c)	
-15	-.10		7(a)	
-15	-.15		↓(b)	
-15	-.20		↓(c)	
0	-.10		Sealed	8(a)
0	-.15			↓(b)
0	-.20			↓(c)
-5	-.10	9		
-10	-.10	10		
-15	-.10	11(a)		
-15	-.15	↓(b)		
-15	-.20	↓(c)		

NATIONAL ADVISORY
 COMMITTEE FOR AERONAUTICS

LIFT AND HINGE-MOMENT PARAMETERS FOR A 0.25c PLAIN
 FLAP WITH A 2.00c_f TAB ON AN NACA 0009 AIRFOIL
 IN THE LANGLEY 4- BY 6-FOOT VERTICAL TUNNEL

Configuration		c_{l_a}	c_{l_b}	c_d	c_{h_a}	c_{h_b}
δt_o (deg)	$c_{\delta t}/c_{\delta f}$					
Gaps open						
0	-0.10	0.090	0.0370	-0.40	-0.0015	-0.0038
0	-0.15	.092	.0320	-.35	.0007	.0004
0	-0.20	.093	.0265	-.23	.0044	.0049
-5	-0.10	.039	.0365	-.41	-.0006	-.0042
-5	-0.15	.091	.0330	-.36	-.0005	-.0004
-5	-0.20	.089	.0275	-.31	.0044	.0044
-10	-0.10	.092	.0370	-.40	-.0016	-.0040
-10	-0.15	.091	.0340	-.37	.0007	.0010
-10	-0.20	.091	.0270	-.20	.0042	.0043
-15	-0.10	.094	.0360	-.38	-.0022	-.0034
-15	-0.15	.093	.0320	-.34	.0005	0
-15	-0.20	.095	.0275	-.29	.0041	.0043
Gaps sealed						
0	-0.10	0.096	0.0410	-0.43	-0.0018	-0.0026
0	-0.15	.097	.0365	-.40	.0003	.0014
0	-0.20	.096	.0300	-.36	.0046	.0054
-5	-0.10	.097	.0385	-.40	-.0016	-.0032
-10	-0.10	.097	.0420	-.45	0	-.0014
-15	-0.10	.099	.0420	-.42	-.0018	-.0036
-15	-0.15	.097	.0380	-.39	.0012	.0007
-15	-0.20	.099	.0345	-.35	.0044	.0049

NATIONAL ADVISORY
 COMMITTEE FOR AERONAUTICS

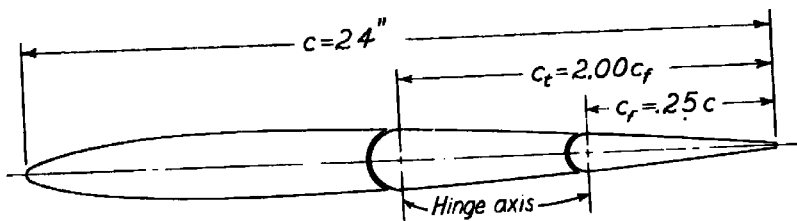

(a) Chord dimensions of airfoil.

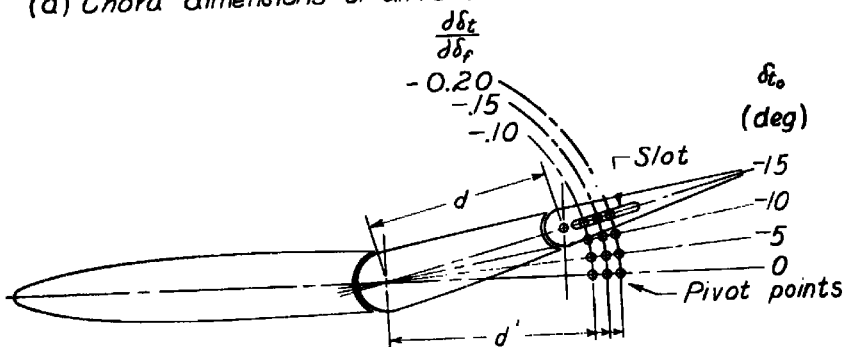

(b) Position of tab when used for trimming. $\delta_f = 0^\circ$.

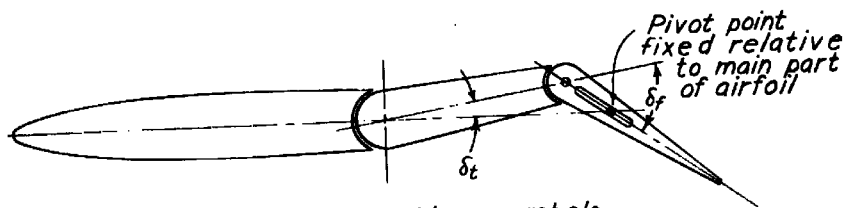

(c) Definition of deflection symbols.

NATIONAL ADVISORY
COMMITTEE FOR AERONAUTICS

Figure 1.-Arrangement of $2.00 c_f$ tab model for various deflection rates and tab trim positions. NACA 0009 airfoil.

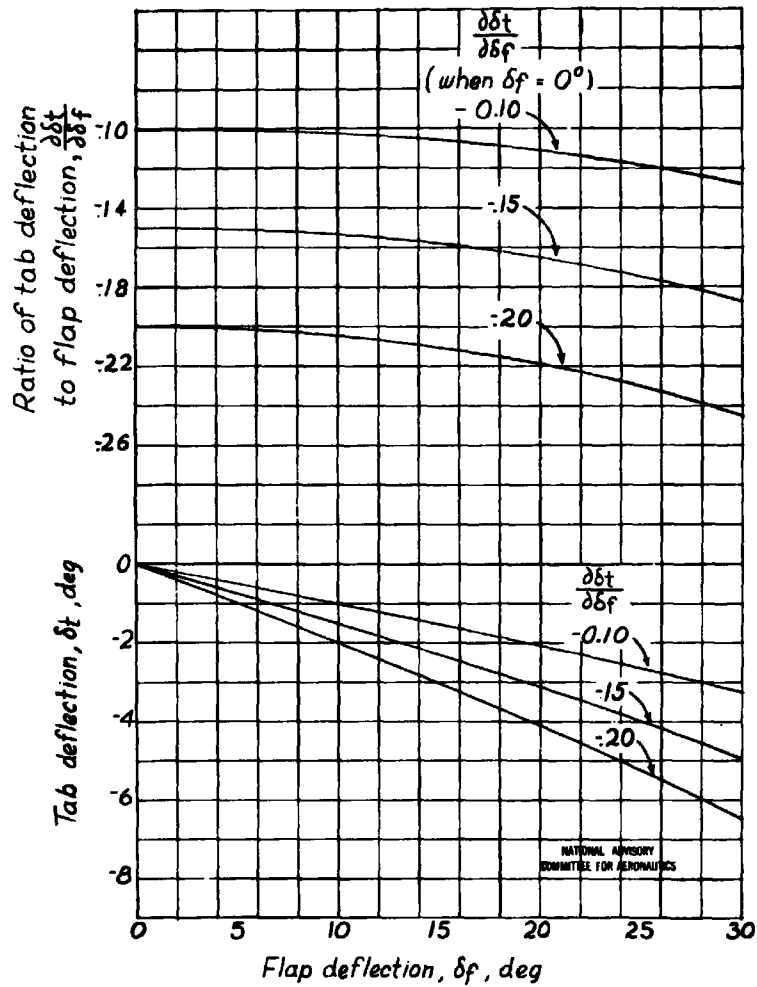

Figure 2.- Characteristics of linkage tested on the NACA 0009 airfoil with a 0.25c flap and a 2.00cf tab.

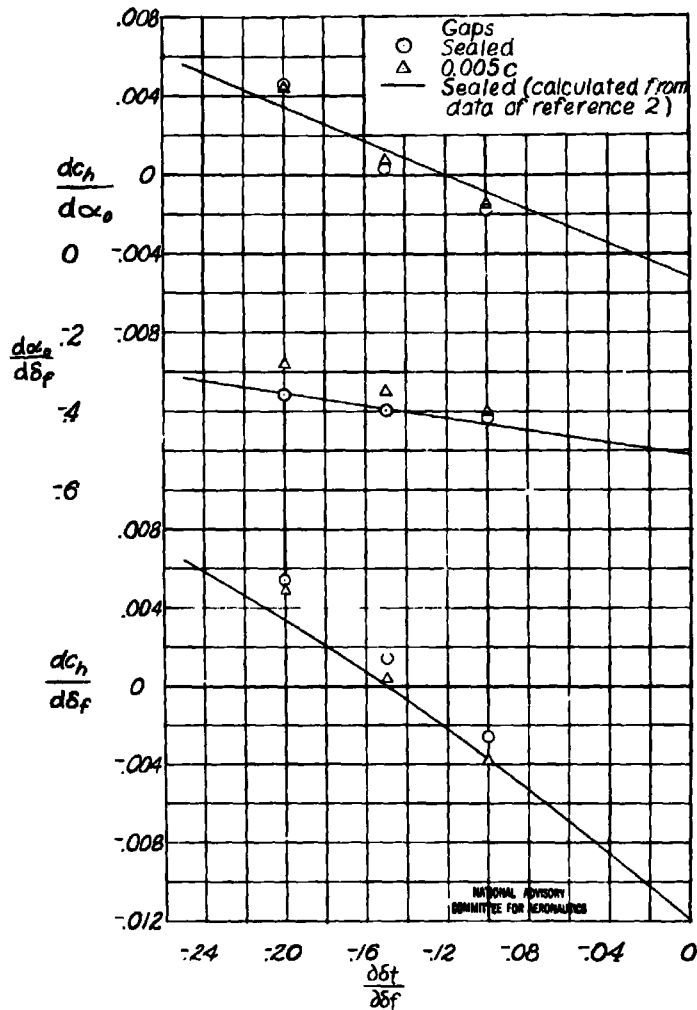
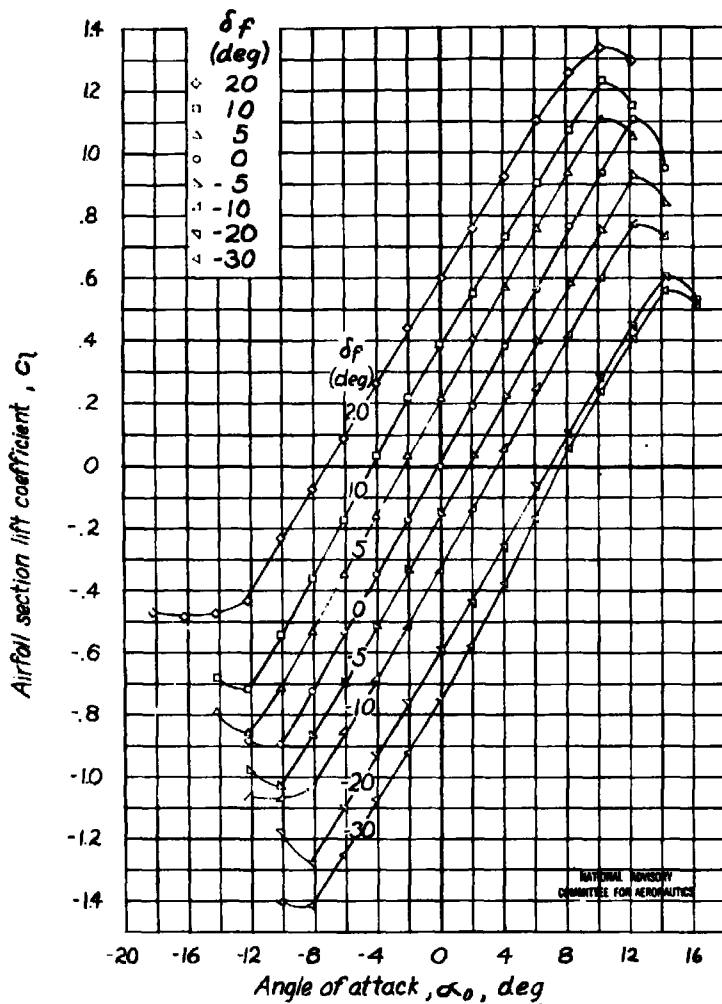

Figure 3 - Comparison of the aerodynamic characteristics of the 2.00c_f lab on NACA 0009 airfoil obtained from experiment and from calculations.

Fig. 4a

NACA ARR No. L5G25



(a) Gaps, $0.005c$; $\delta_{t_0} = 0^\circ$, $\partial \delta_t / \partial \delta_f = -0.10$.
 Figure 4.- Aerodynamic section characteristics of an NACA 0009 airfoil having a $0.25c$ flap and a $2.00c_f$ tab with various linkages.

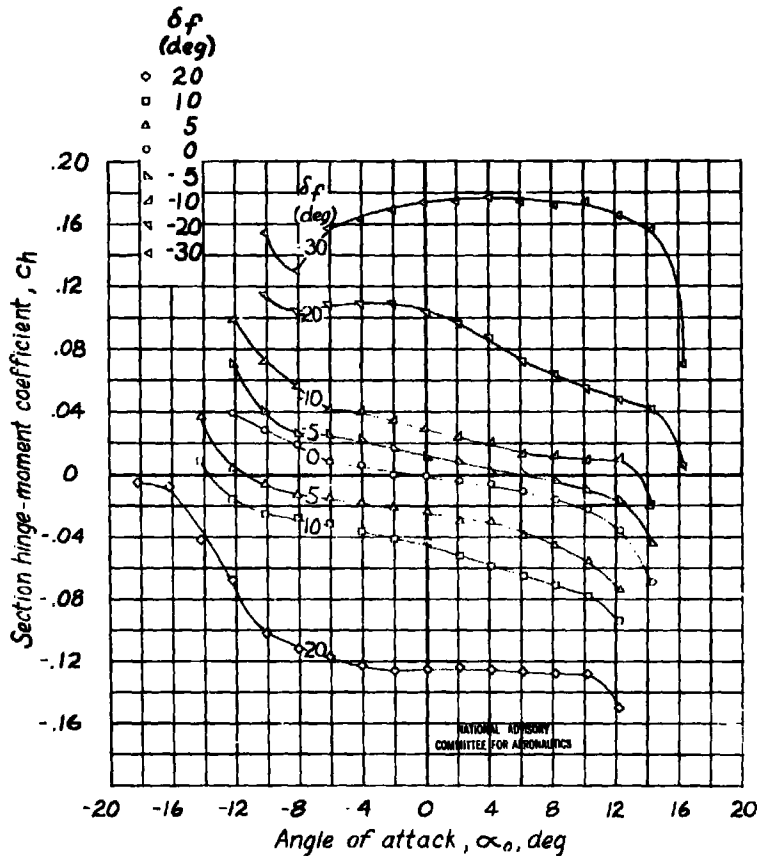

(a) Gaps, 0.005c; $\delta_0 = 0^\circ$; $\delta_f/\delta_p = -0.10$. Concluded.
 Figure 4. - Continued.

Fig. 4b

NACA ARR No. L5025

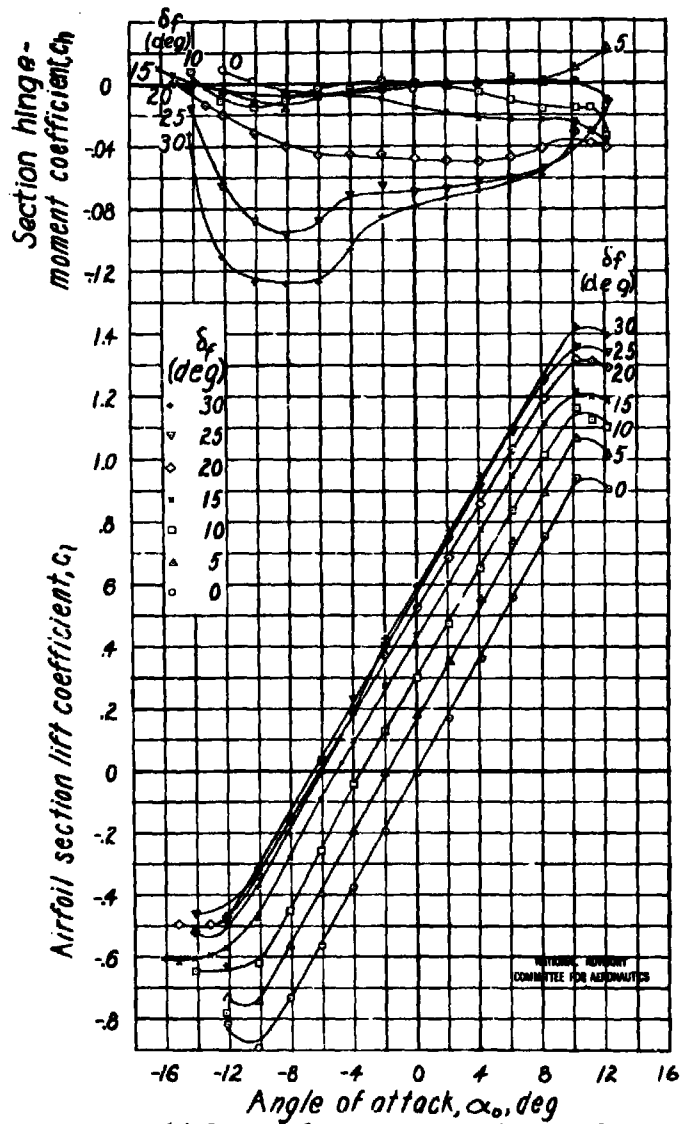

(b) Gaps, $0.005c$, $\delta\alpha_0 = 0^\circ$; $\partial\delta_f/\partial\alpha_f = -0.15$.
 Figure 4.- Continued.

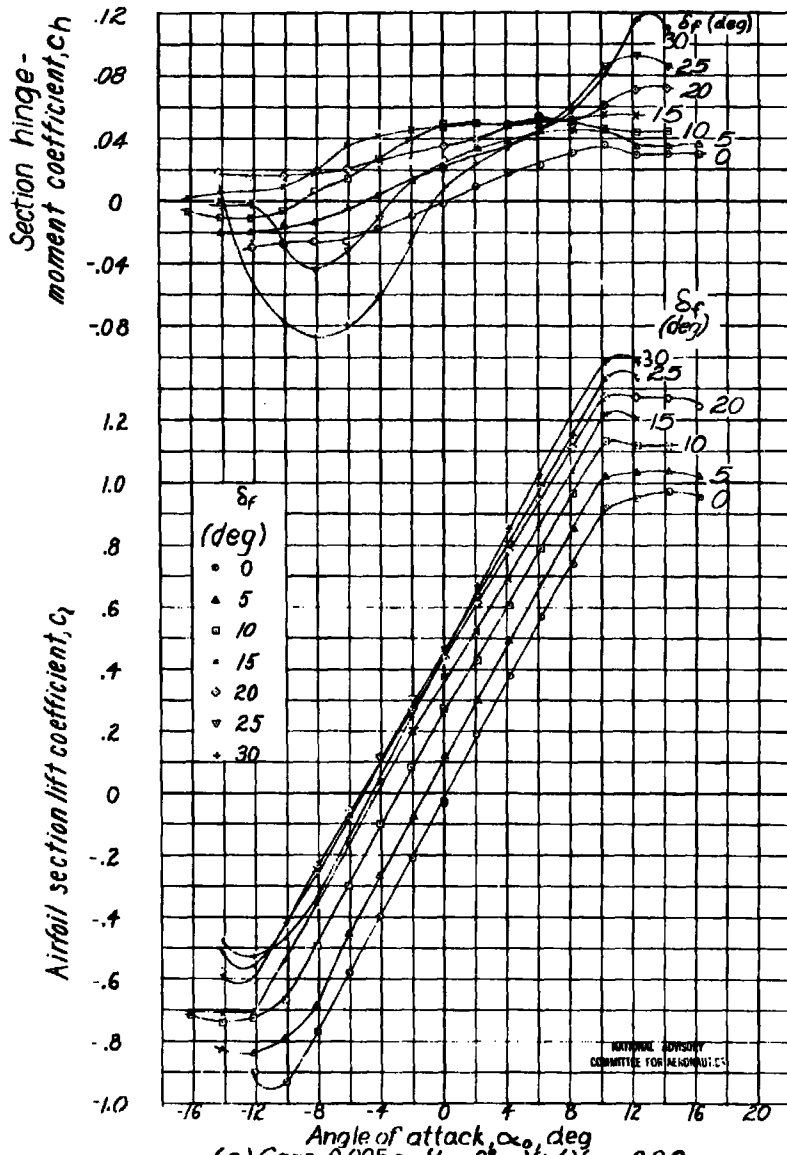

(c) Caps, 0.005c; $\delta_{f_0} = 0^\circ$; $\delta \delta_f / \delta \delta_f = -0.20$.
 Figure 4. - Concluded

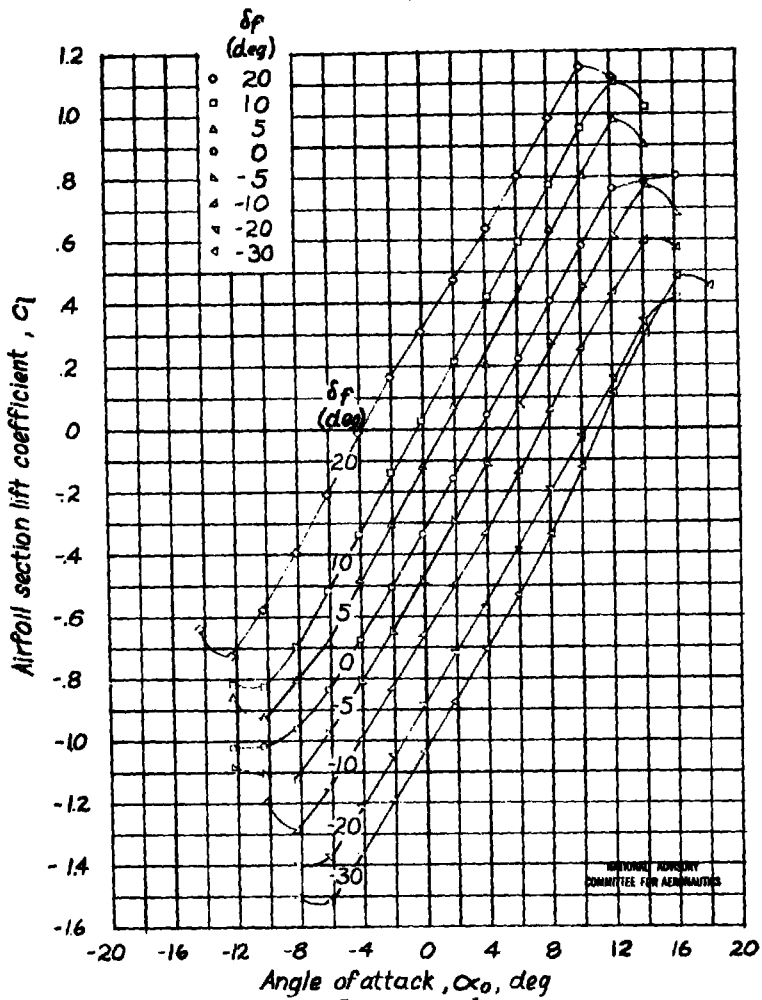

(a) $C_{aps}, 0.005c$; $\delta_{t_0} = -5^\circ$; $\delta\alpha/\delta\delta_f = -0.10$.

Figure 5.- Aerodynamic section characteristics of an NACA 0009 airfoil having a 0.25c flap and a 2.00c_f tab with various linkages.

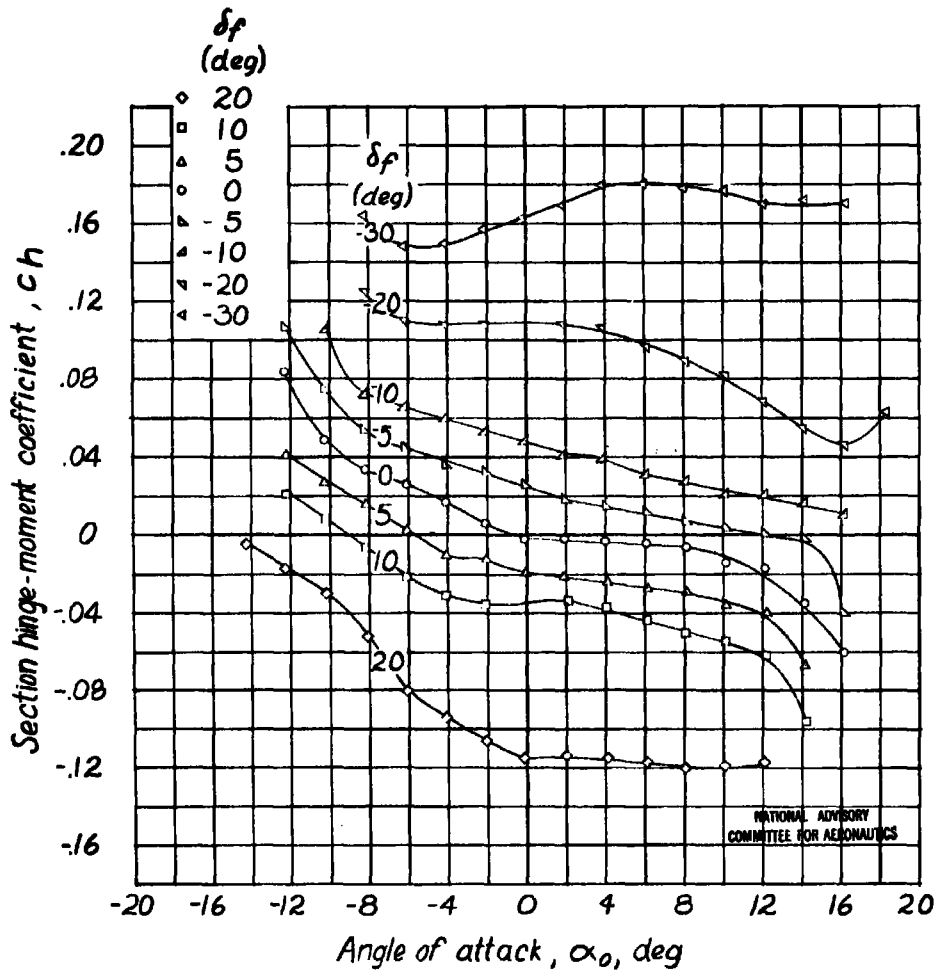

(a) Gaps, $0.005c$; $\delta t_0 = -5^\circ$; $\delta \delta_c / \delta \delta_f = -0.10$. Concluded
 Figure 5. - Continued.

24

Fig. 5b

NACA ARR No. L5G25

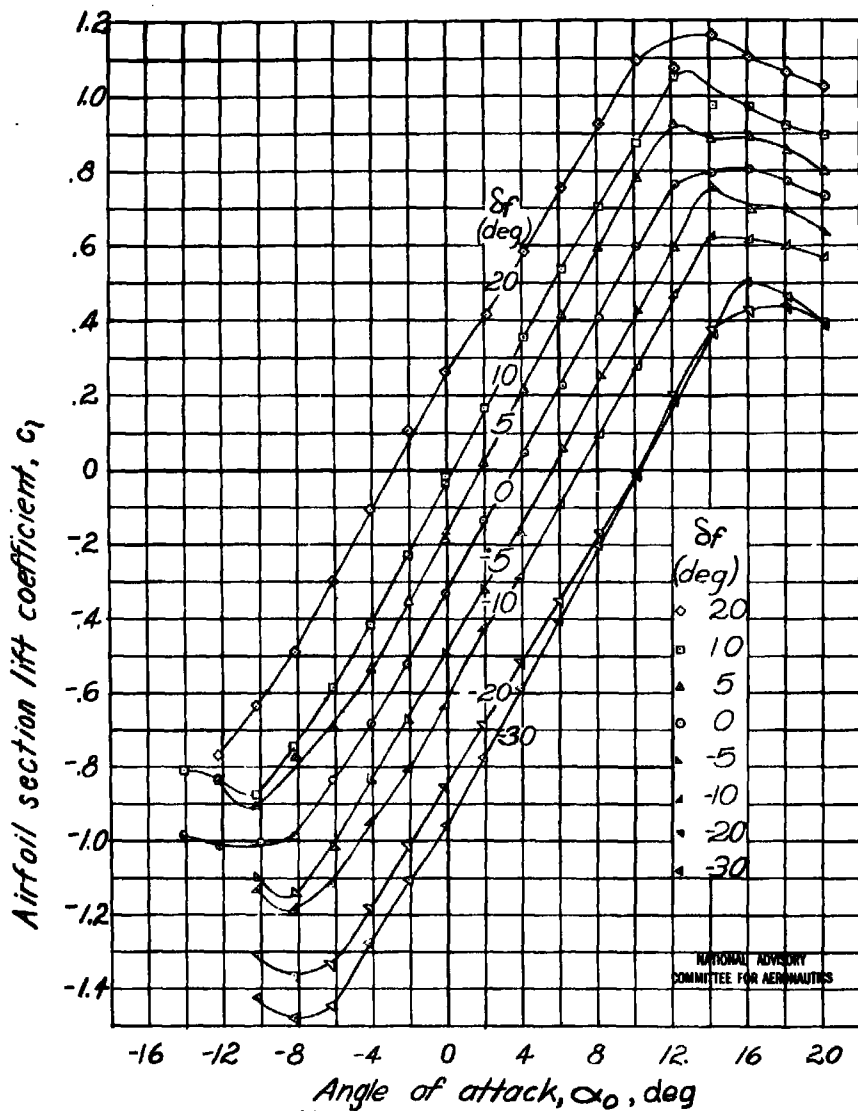

NATIONAL ADVISORY
COMMITTEE FOR AERONAUTICS

(b) Gaps, 0.005c; $\delta t_0 = -5^\circ$; $\partial \delta t / \partial \delta_f = -0.15$.
Figure 5 - Continued.

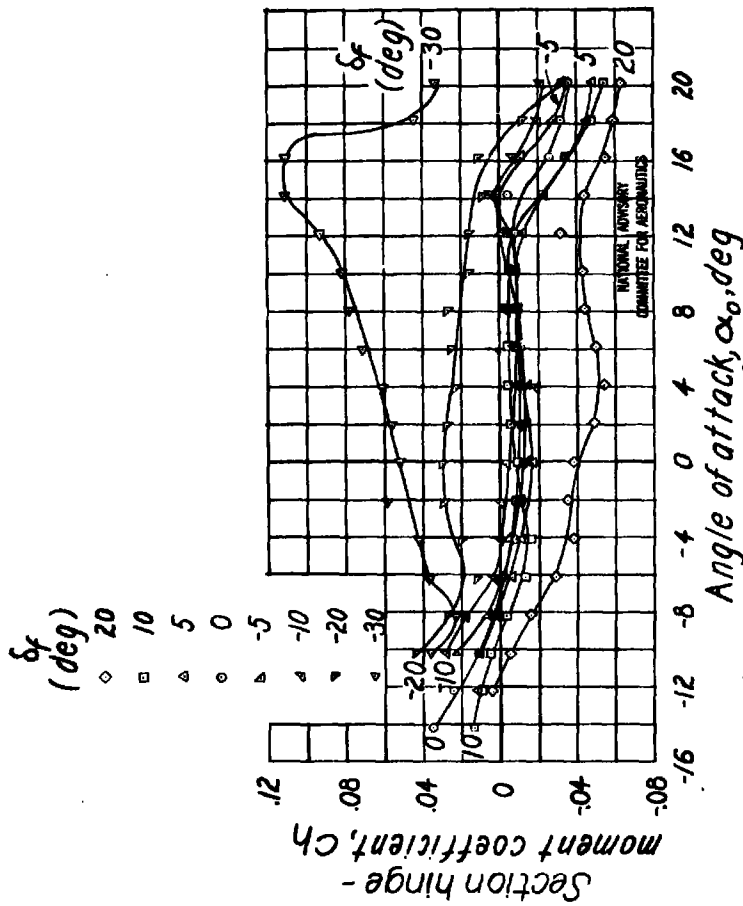

(b) Gaps, 0.005c; $\delta_f = -5^\circ$; $\delta\delta/\delta\alpha = 0.15$. Concluded.

Figure 5.- Continued.

Fig. 5c

NACA ARR No. L5G25

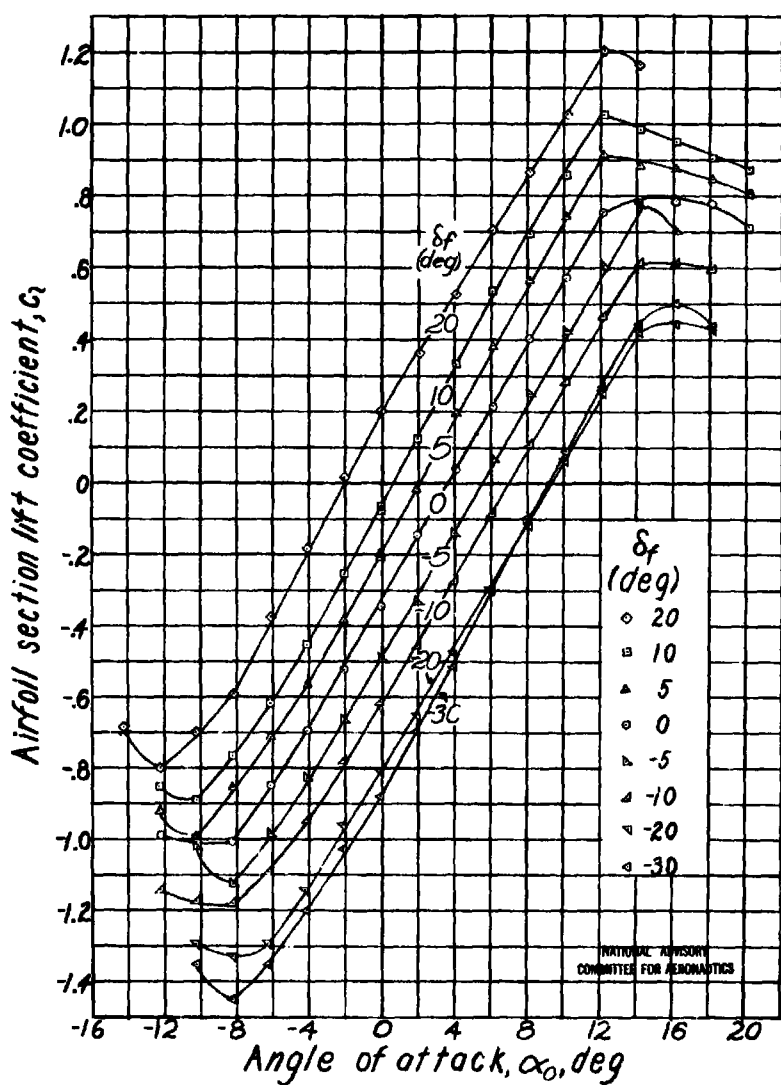

(c) Gaps, $0.005c$; $\delta t_0 = -5^\circ$; $\partial \delta t / \partial \delta f = -0.20$.
 Figure 5.- Continued.

Fig. 5c Conc.

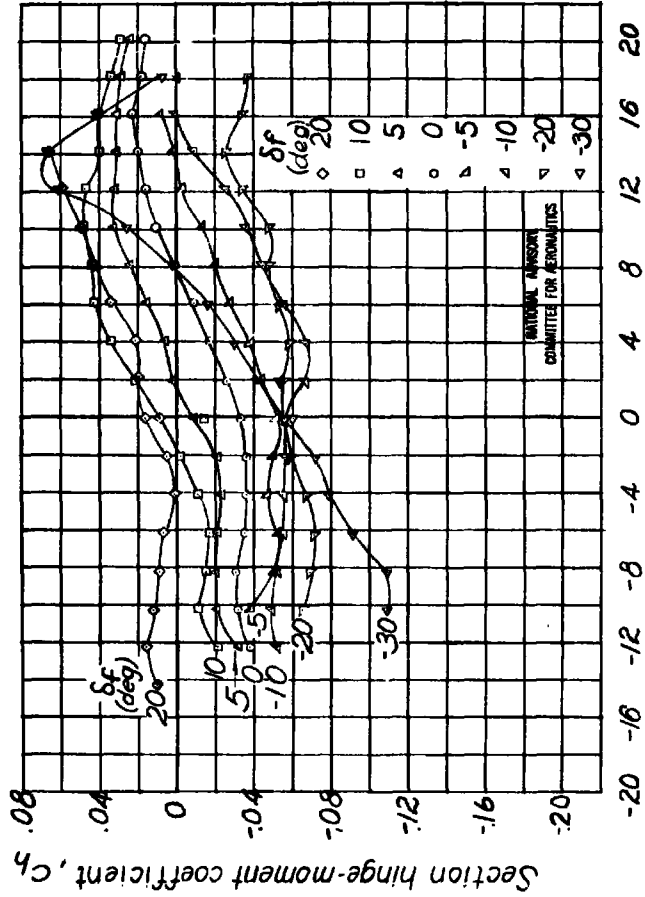

Angle of attack, α_0 , deg
 (c) Gaps, 0.005c; $\delta_{t_0} = -5^\circ$, $\delta_{t_1}/\delta_{t_0} = -0.20$. Concluded.
 Figure 5. Concluded.

Fig. 6a

NACA ARR No. L5G25

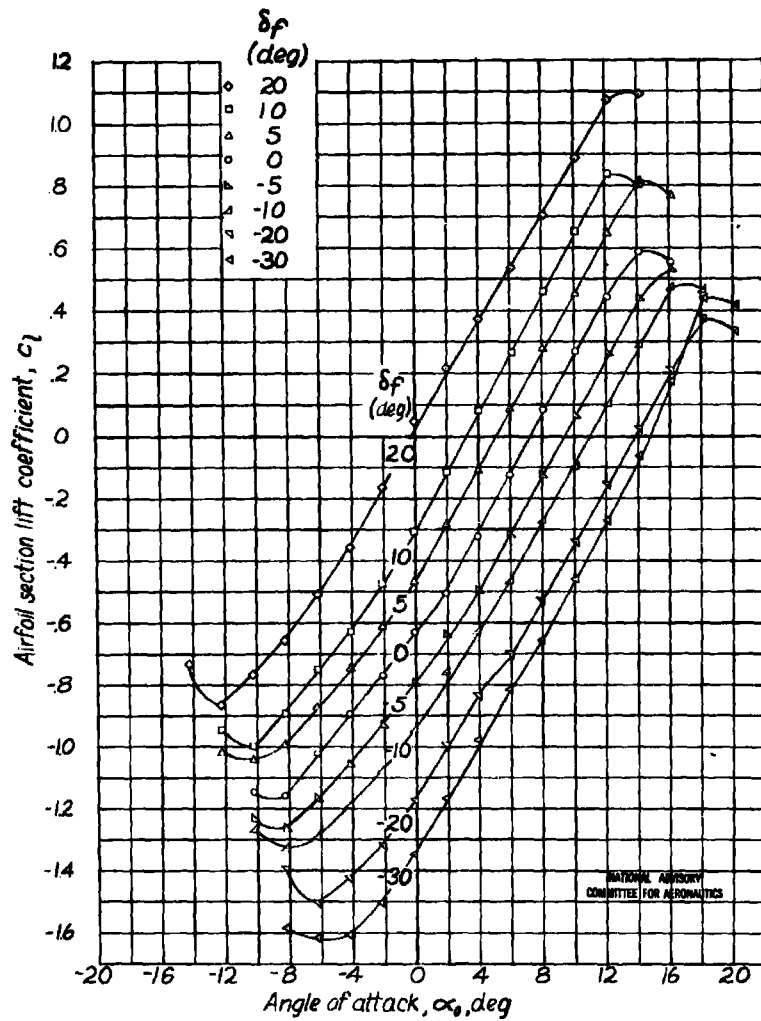

(a) Gaps, $0.005c$; $\delta_{t_0} = -10^\circ$; $\partial \delta_t / \partial \delta_f = -0.10$.

Figure 6.- Aerodynamic section characteristics of an NACA 0009 airfoil having a $0.25c$ flap and a $2.00c_f$ tab with various linkages.

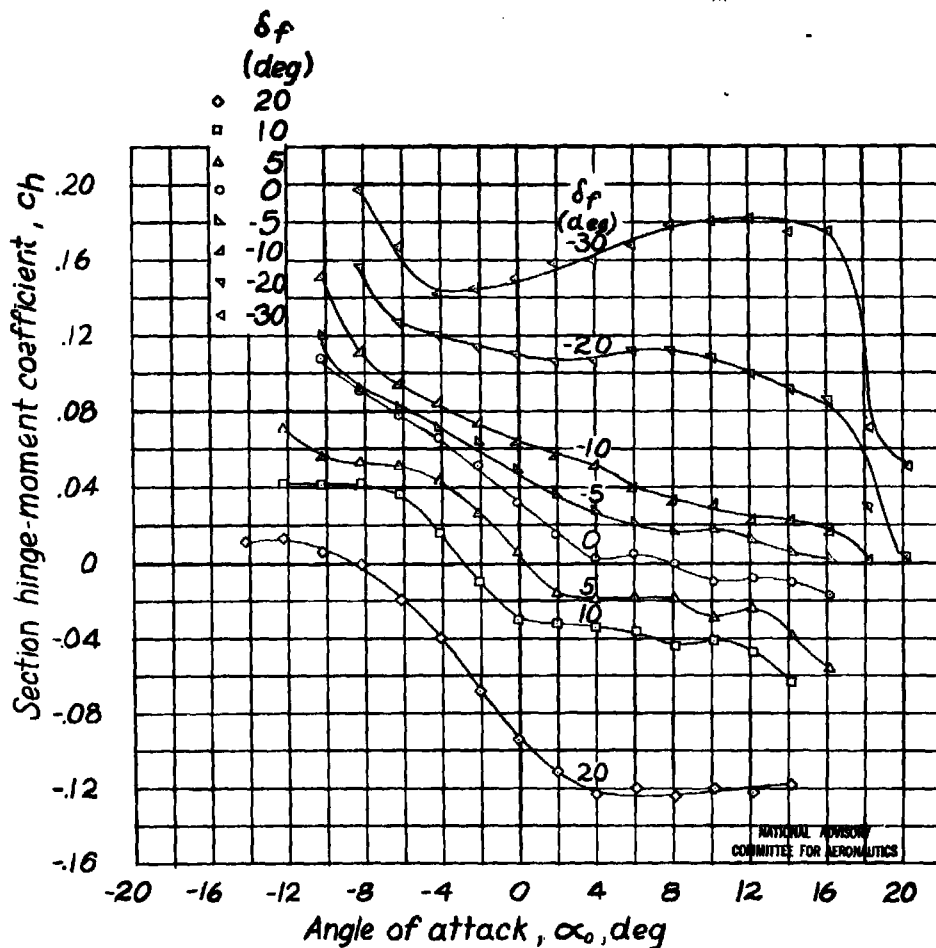

(a) Gaps, $0.005c$; $\delta t_0 = -10^\circ$; $\partial \delta t / \partial \delta_f = -0.10$. Concluded.

Figure 6. - Continued

Fig. 6b

NACA ARR No. L5G25

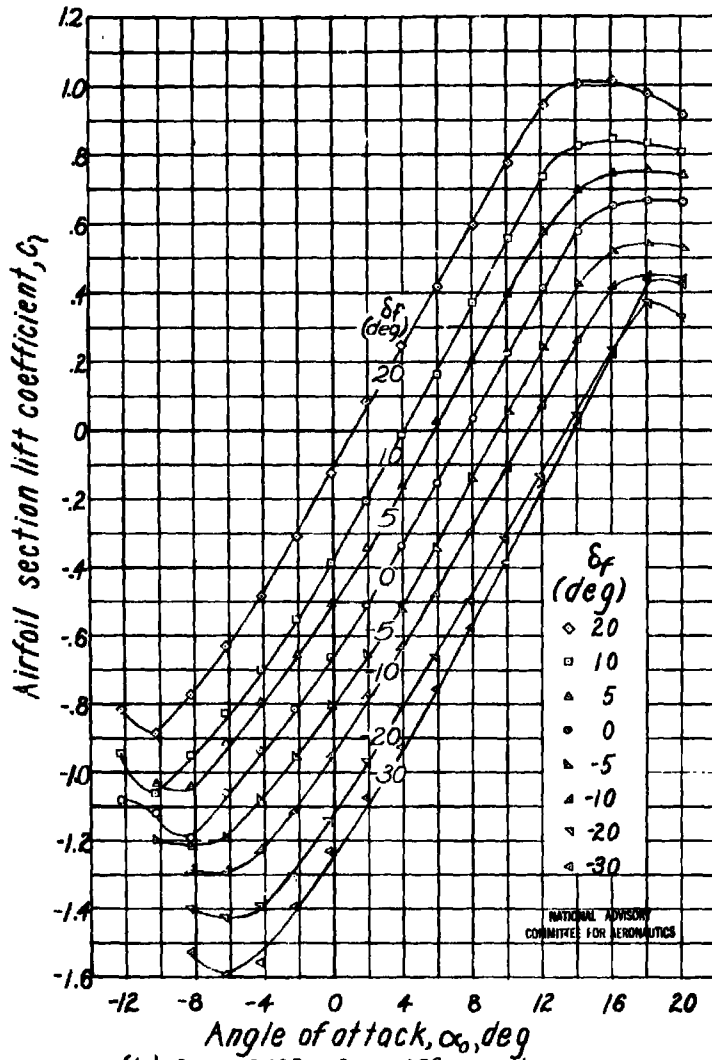

(b) Gaps, $0.005c$; $\delta t_0 = -10^\circ$; $\partial \delta t / \partial \delta f = -0.15$.
Figure 6.- Continued.

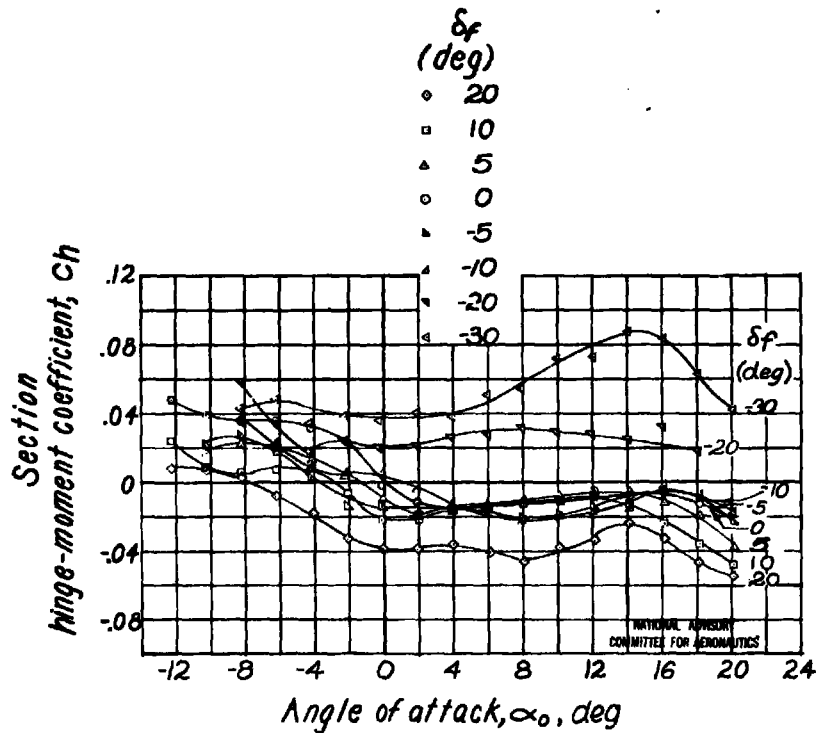

(b) Gaps, 0.005c; $\delta_{t_0} = -10^\circ$; $\partial \delta_t / \partial \delta_f = -0.15$. Concluded.

Figure 6.- Continued.

Fig. 6c

NACA ARR No. L5025

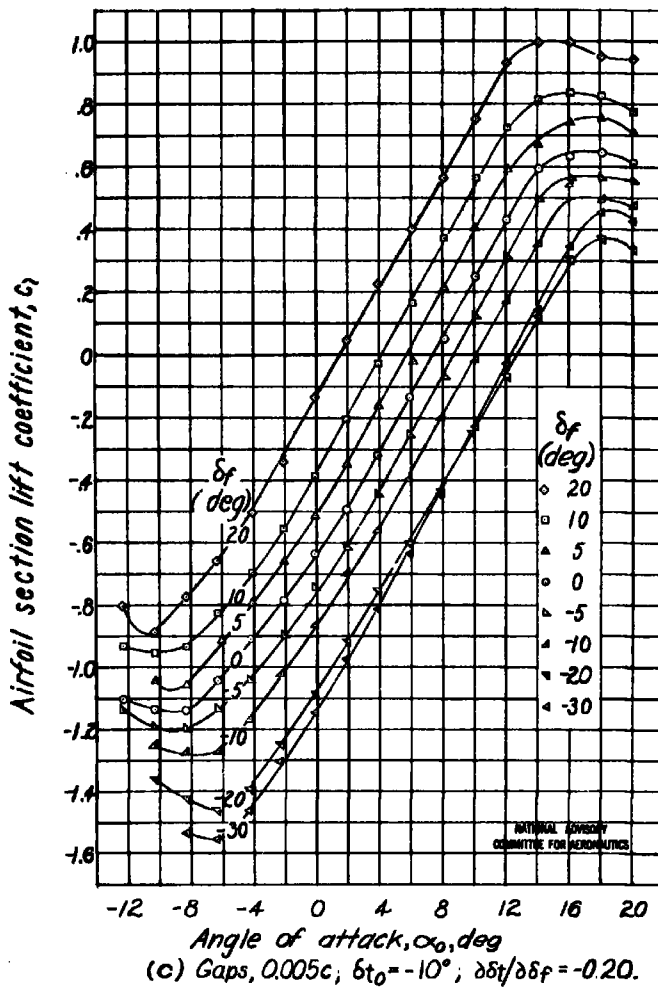
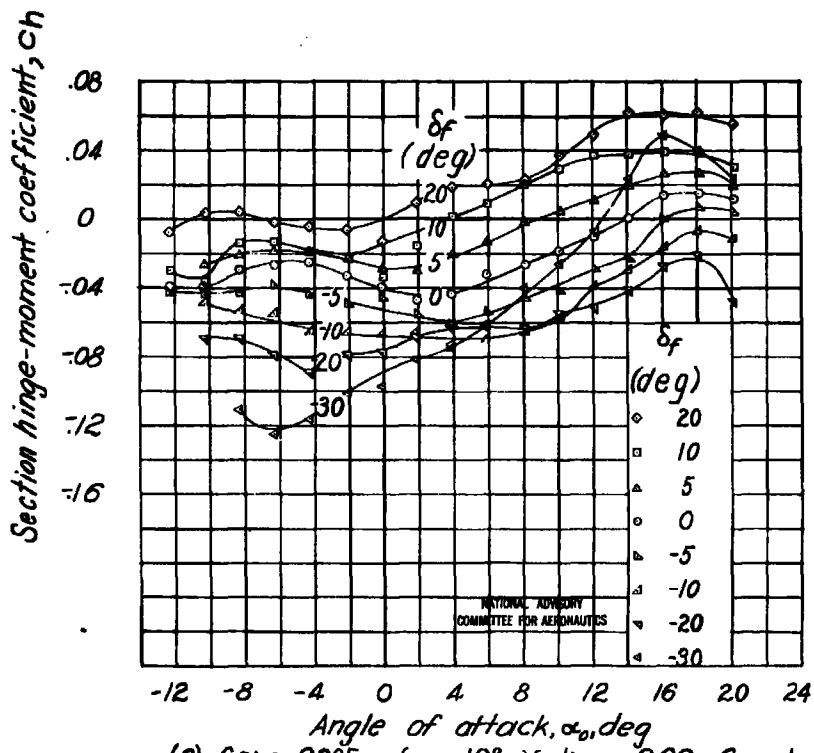

Figure 6.- Continued.



(c) Gaps, 0.005c; $\delta_{t_0} = -10^\circ$; $\partial \delta_t / \partial \delta_f = -0.20$. Concluded.
 Figure 6.- Concluded.

34

Fig. 7a

NACA ARR No. L5G25

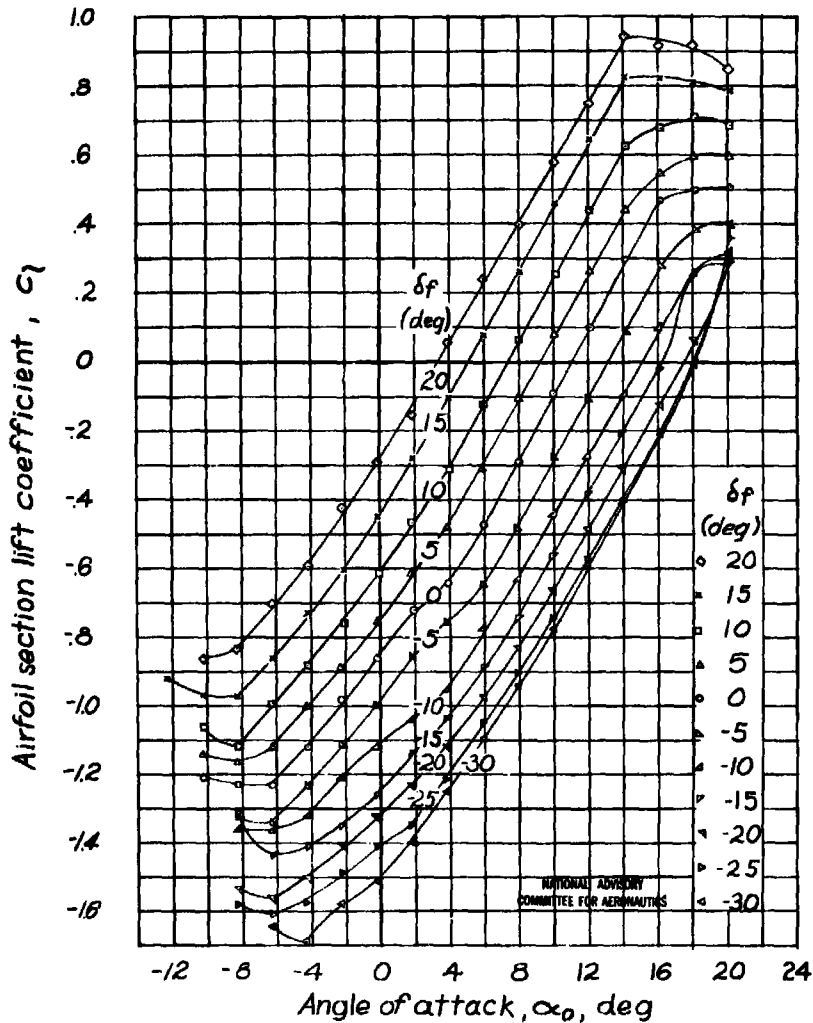

(a) Gaps, $0.005c$; $\delta t_0 = -15^\circ$; $\delta \delta_f / \delta \delta_f = -0.10$.
 Figure 7.- Aerodynamic section characteristics of an NACA 0009 airfoil having a $0.25c$ flap and a $2.00c_f$ tab with various linkages.

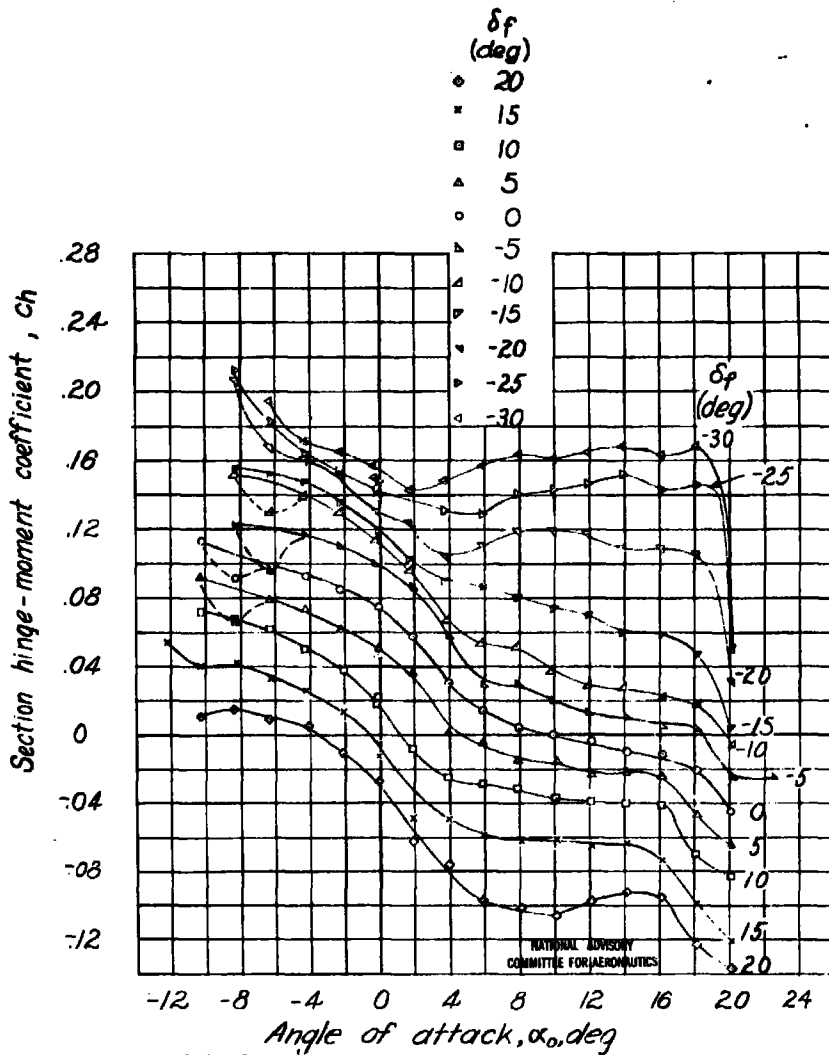

(a) Gaps, 0.005c; $\delta t_0 = -15^\circ$; $\delta t / \delta \delta_f = -0.10$. Concluded.
Figure 7.-Continued.

Fig. 7b

NACA ARR No. L5G25

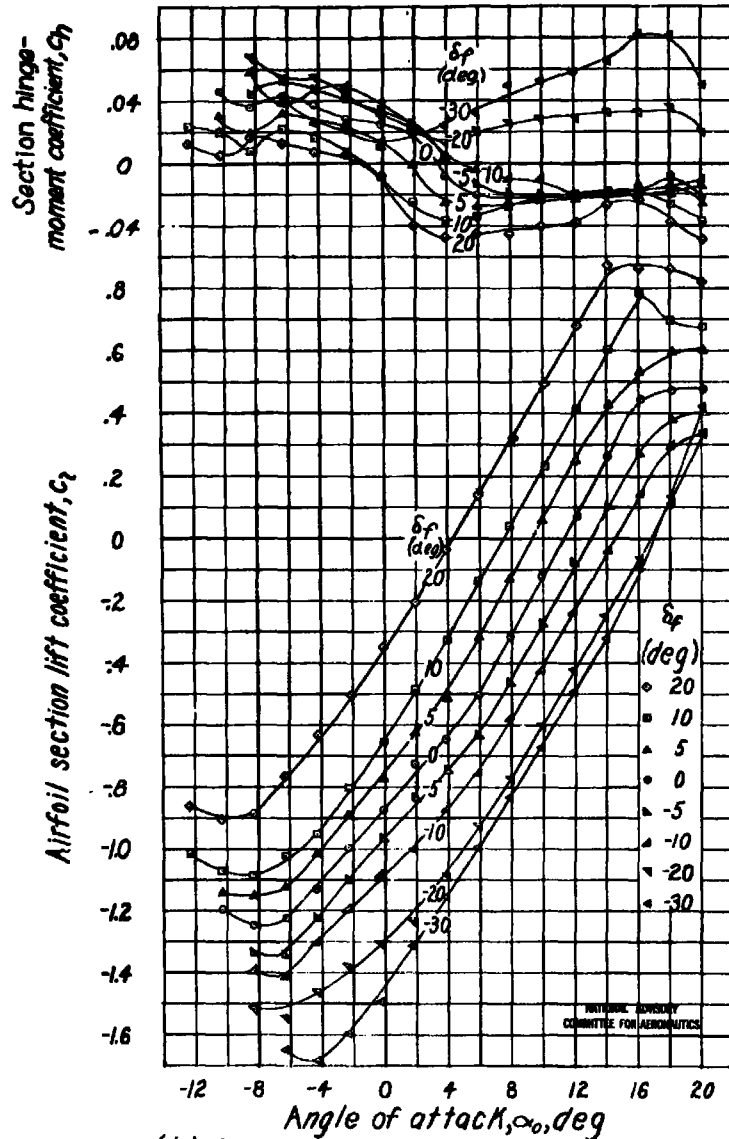

(b) Gaps, $0.005c$; $\delta t_0 = -15^\circ$; $\partial \delta t / \partial \delta f = -0.15$.

Figure 7.- Continued.

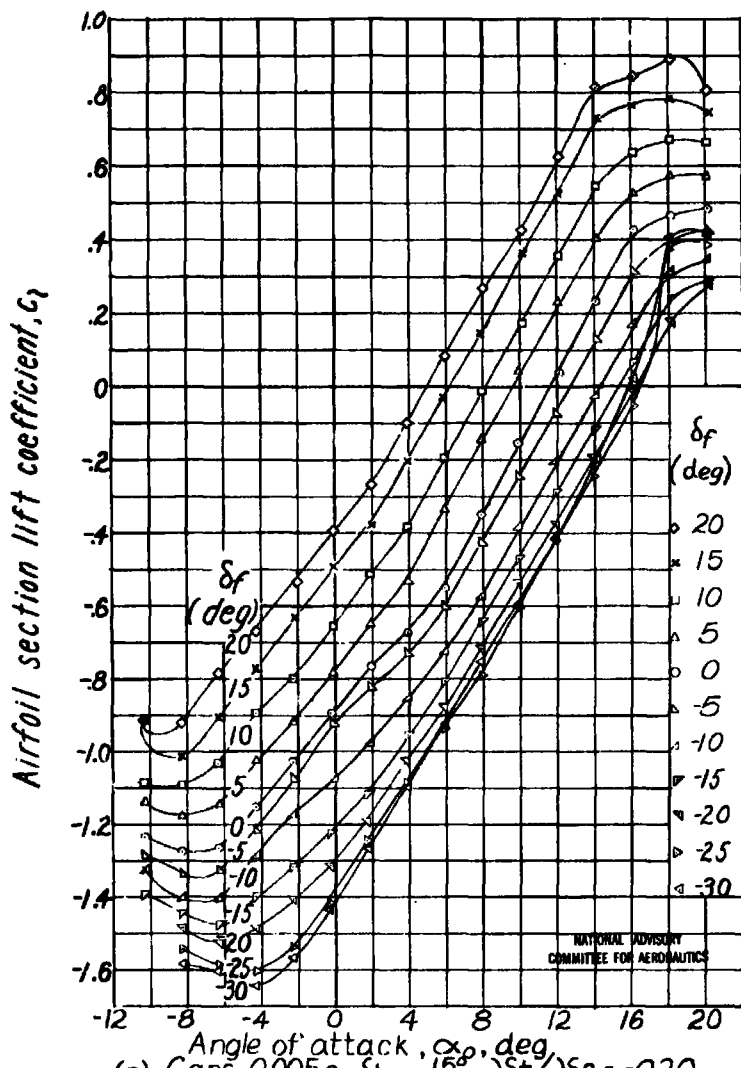
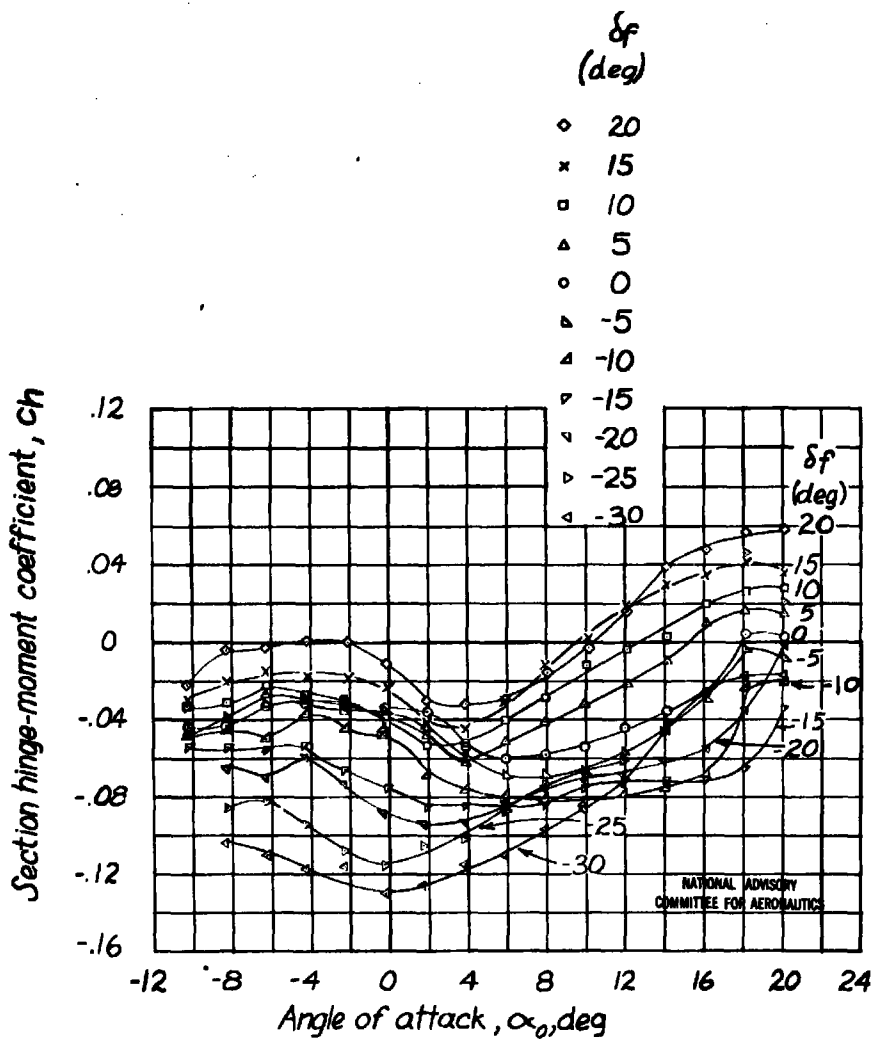

Figure 7.-Continued.

Fig. 7c Conc.

NACA ARR No. L5G25



(c) Gaps, $0.005c$; $\delta_{t_0} = -15^\circ$; $\partial \delta_t / \partial \delta_f = -0.20$. Concluded.

Figure 7.- Concluded.

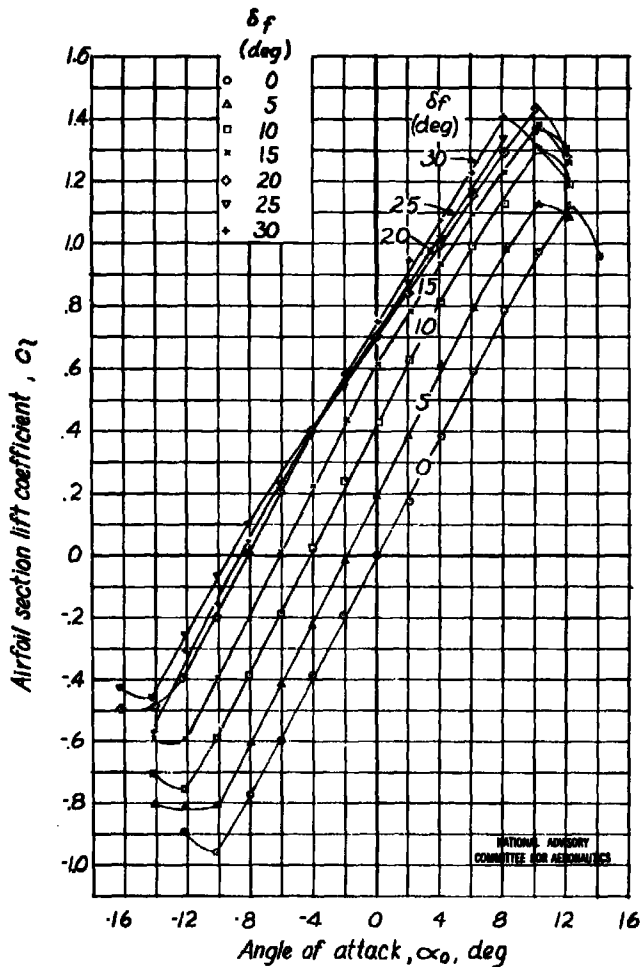

(a) Gaps sealed; $\delta t_0 = 0^\circ$; $\partial \delta t / \partial \delta_f = -0.10$
 Figure 8.- Aerodynamic section characteristics of an NACA 0009 airfoil having a 0.25c flap and a 2.00c_f tab with various linkages.

Fig. 8a Conc.

NACA ARR No. L5G25

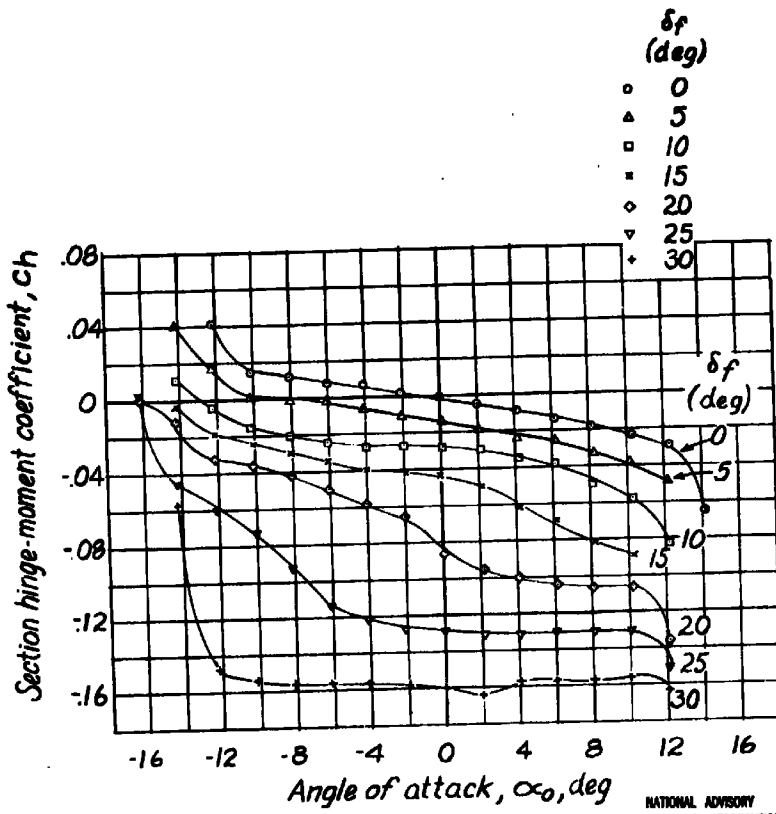

(a) Gaps sealed ; $\delta t_0 = 0^\circ$; $\partial \delta t / \partial \delta f = -0.10$. Concluded.

Figure 8.- Continued.

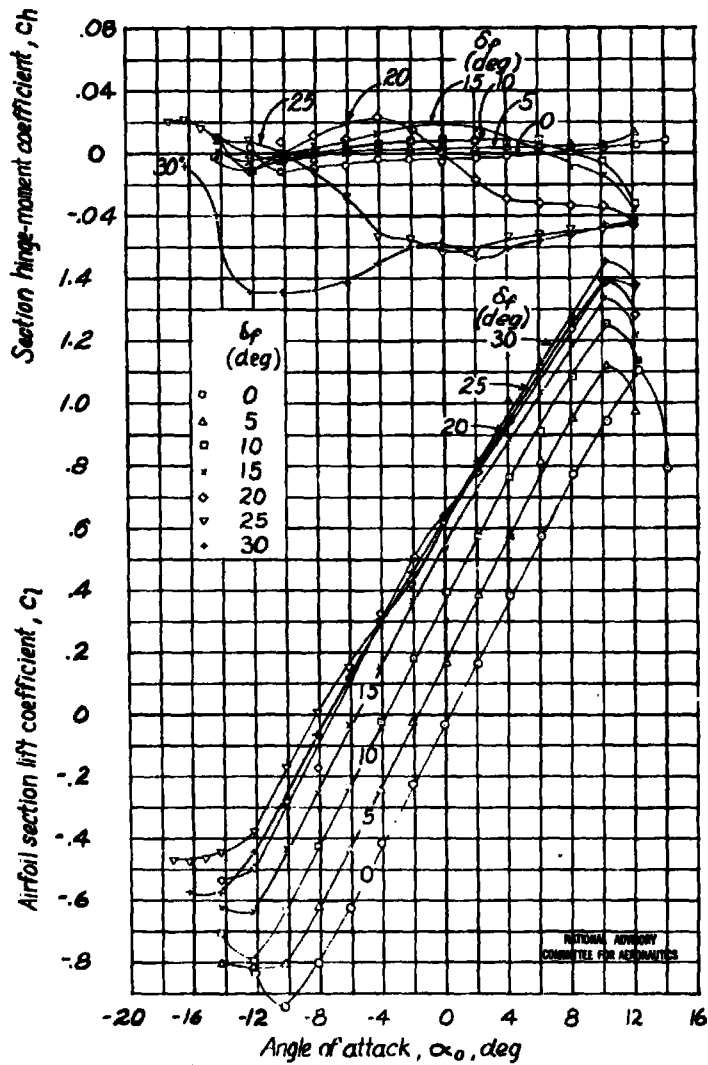

(b) Gaps sealed; $\delta t_0 = 0^\circ$; $\delta \delta t / \delta \delta f = -0.15$.
 Figure 8.- Continued.

Fig. 8c

NACA ARR No. L5G25

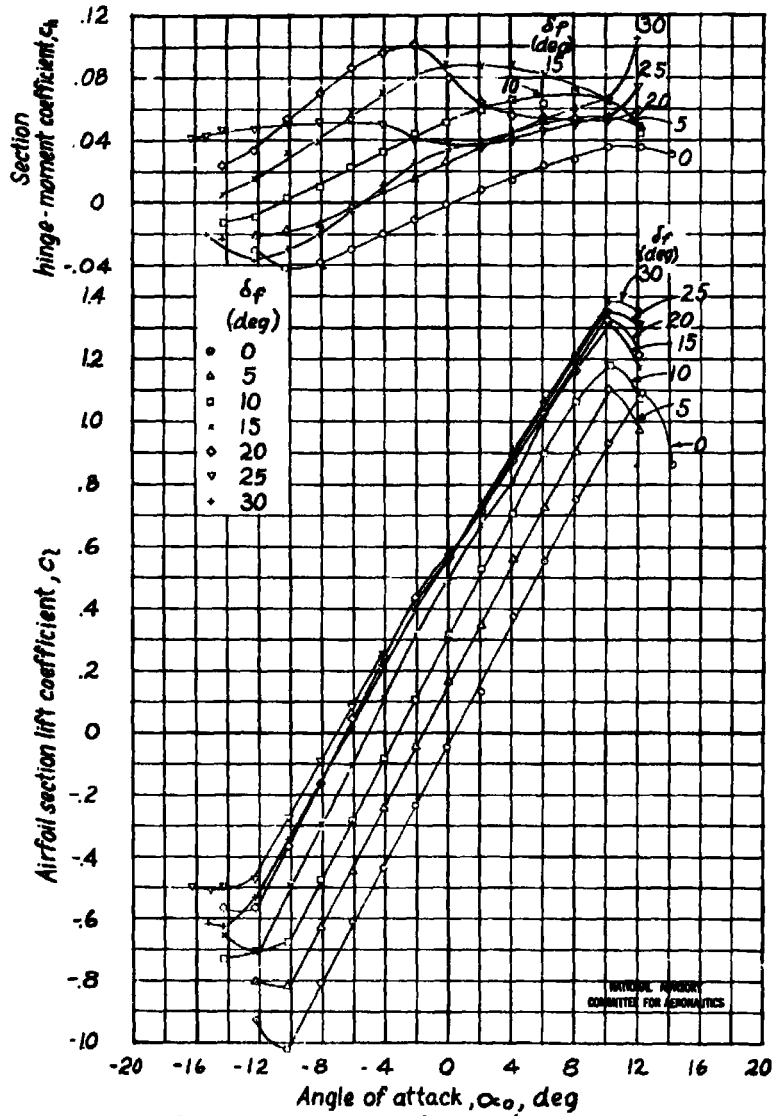

(c) Gaps sealed; $\delta_{t_0} = 0^\circ$; $\delta \delta_t / \delta \delta_f = -0.20$.

Figure 8.- Concluded.

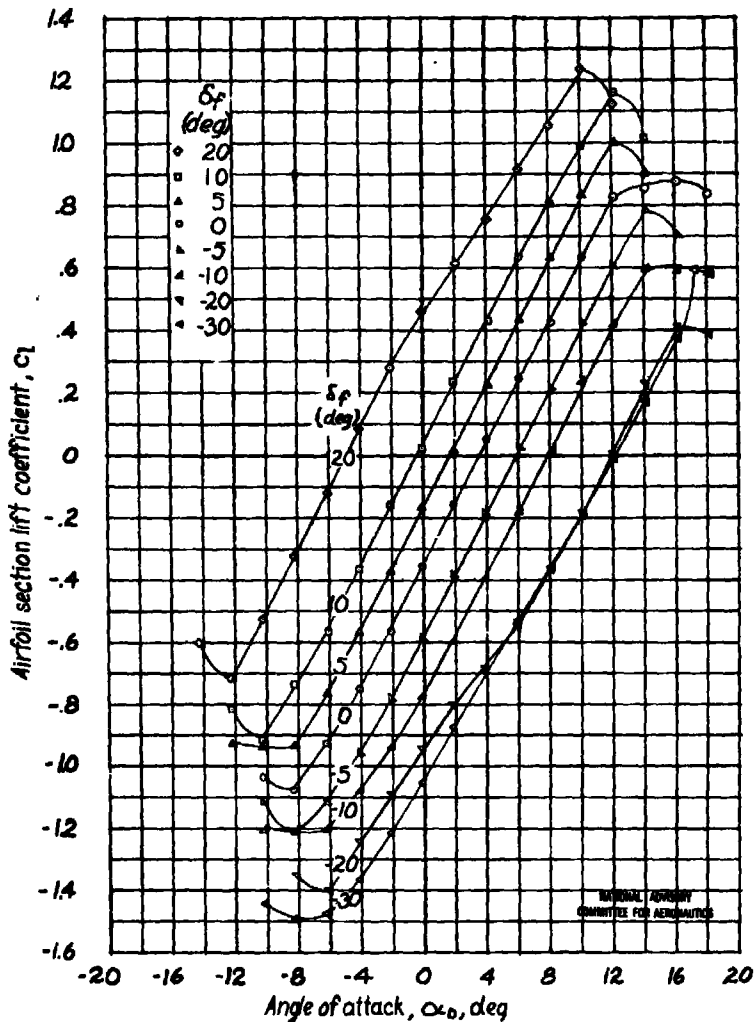

Figure 9.- Aerodynamic section characteristics of an NACA 0009 airfoil having a $0.25c_f$ flap and a $2.00c_f$ tab. Gaps sealed; $\delta_{t_0} = -5^\circ$; $\delta\delta_{t_0}/\delta\delta_f = -0.10$.

44

Fig. 9 Conc.

NACA ARR No. L5G25

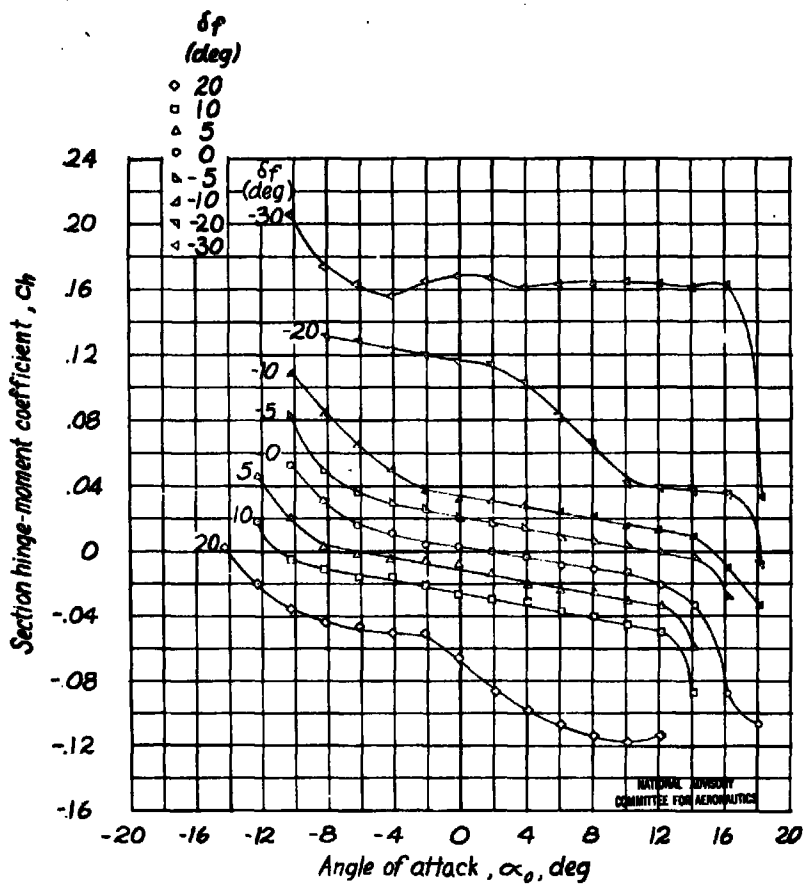

Figure 9.-Concluded.

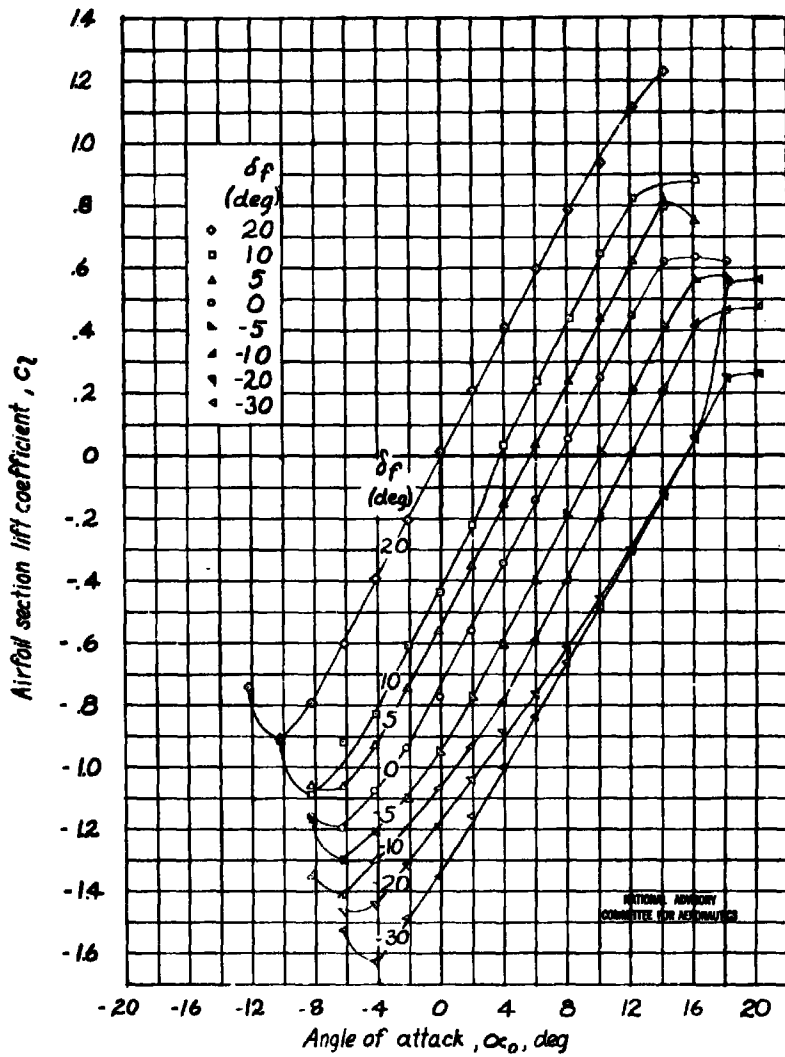

Figure 10.- Aerodynamic section characteristics of an NACA 0009 airfoil having a 0.25c flap and a 2.00c_f tab. Gaps sealed; $\delta_{t_0} = -10^\circ$; $\partial \delta_t / \partial \delta_f = -0.10$.

Fig. 10 Conc.

NACA ARR No. L5G25

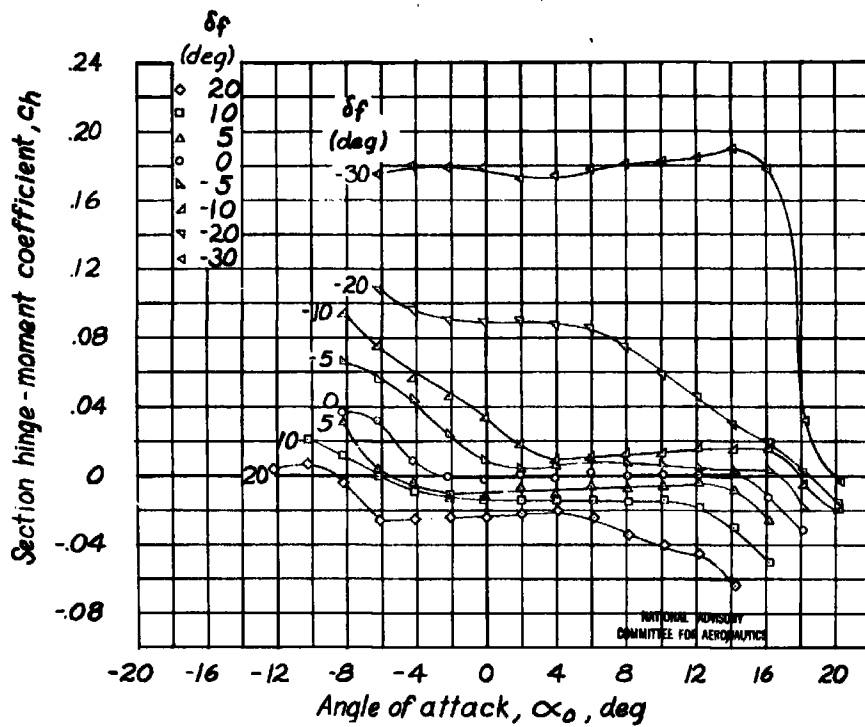
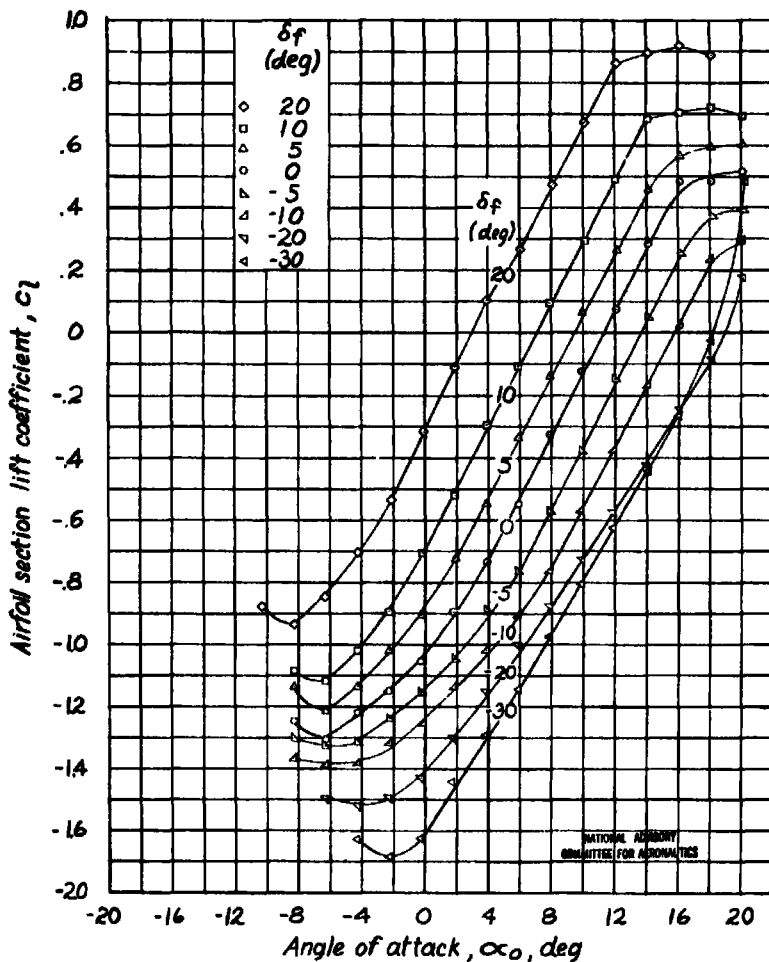

Figure 10.- Concluded.



(a) Gaps sealed; $\delta_{t_0} = -15^\circ$; $\partial \delta_f / \partial \delta_f = -0.10$.

Figure 11. - Aerodynamic section characteristics of an NACA 0009 airfoil having a 0.25c flap and a 2.00c_f tab with various linkages.

Fig. 11a Conc.

NACA ARR No. L5G25

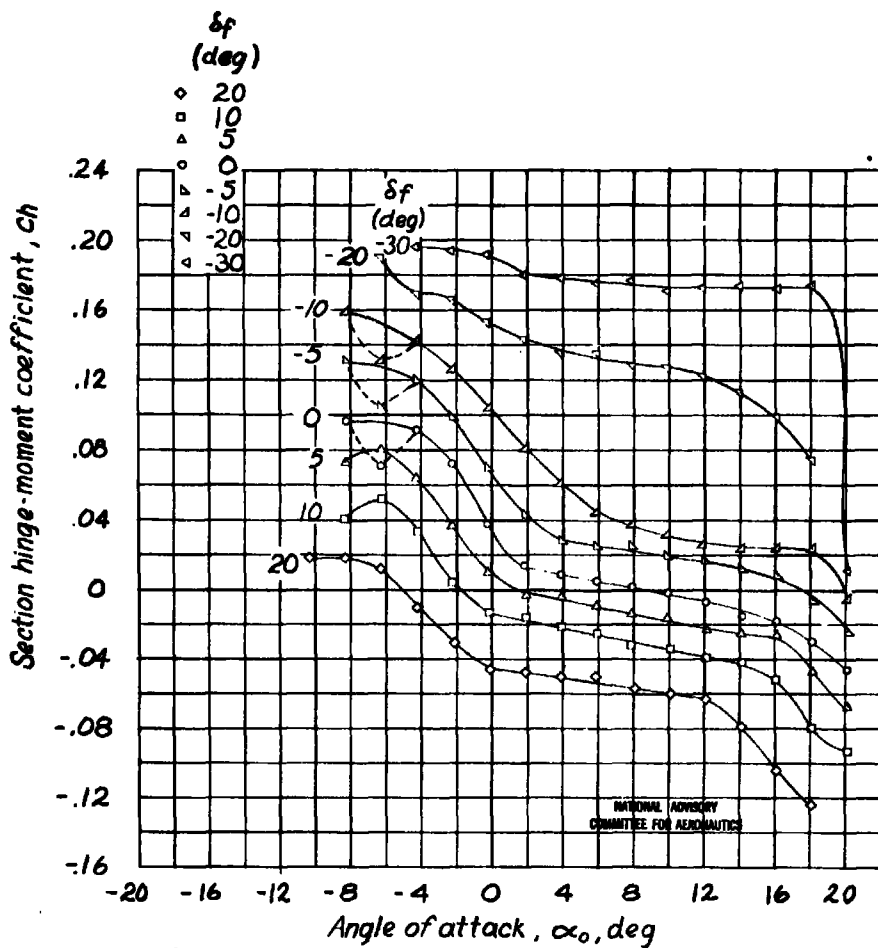

(a) Gaps sealed; $St_0 = -15^\circ$; $\partial \delta f / \partial \delta f = -0.10$. Concluded.
Figure 11.- Continued.

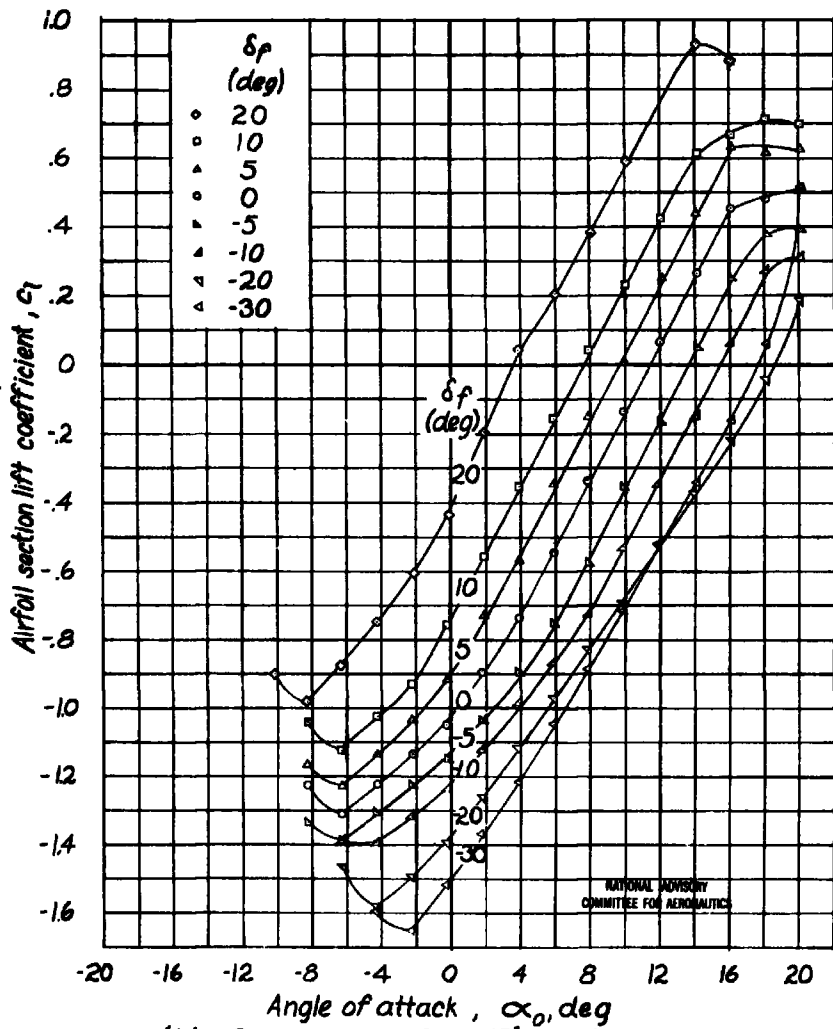

(b) Gaps sealed; $\delta t_0 = -15^\circ$; $\partial \delta t / \partial \delta f = -0.15$.
 Figure 11. - Continued.

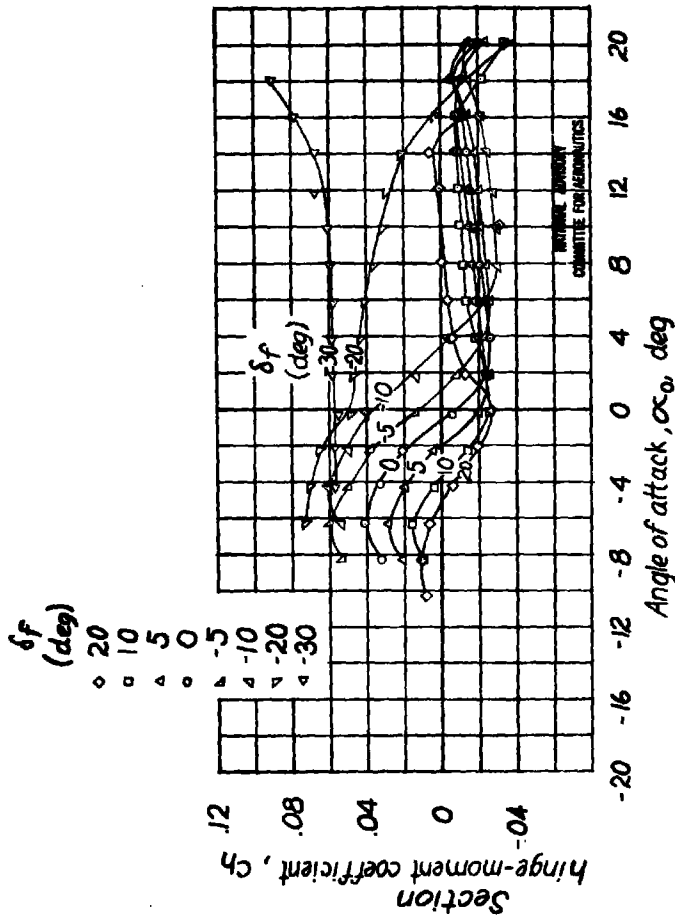

(b) Gaps sealed; $\delta_{t_0} = -15^\circ$; $\delta_t/\delta_f = 0.15$. Concluded.

Figure 11. - Continued.

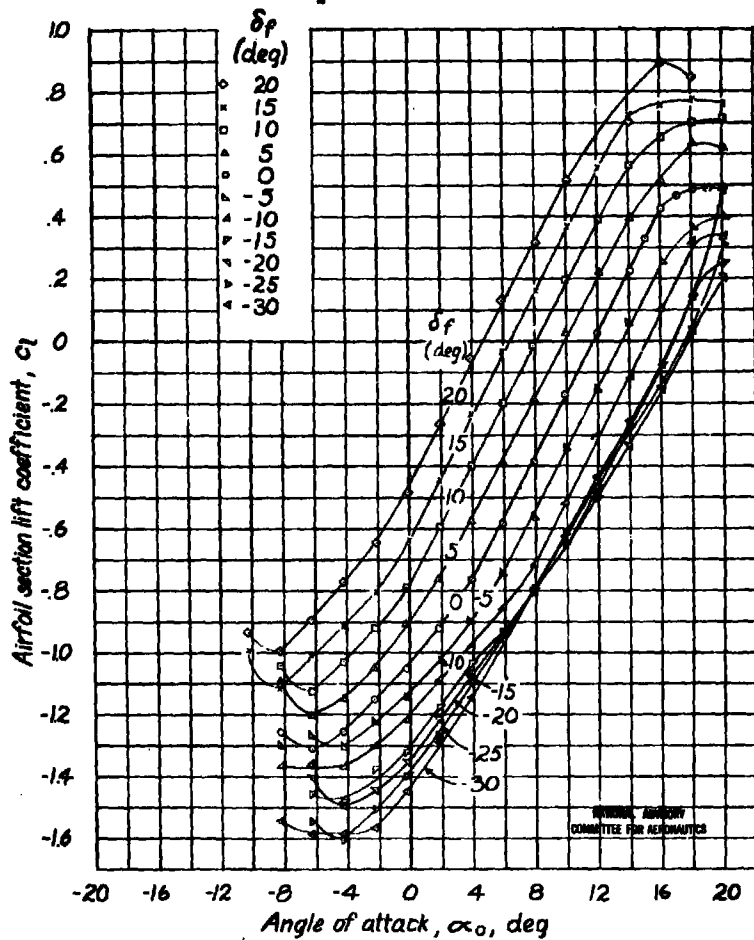

(c) Gaps sealed; $\delta t_o = -15^\circ$; $\delta \delta_f / \delta \delta_f = -0.20$.
 Figure 11. - Continued.

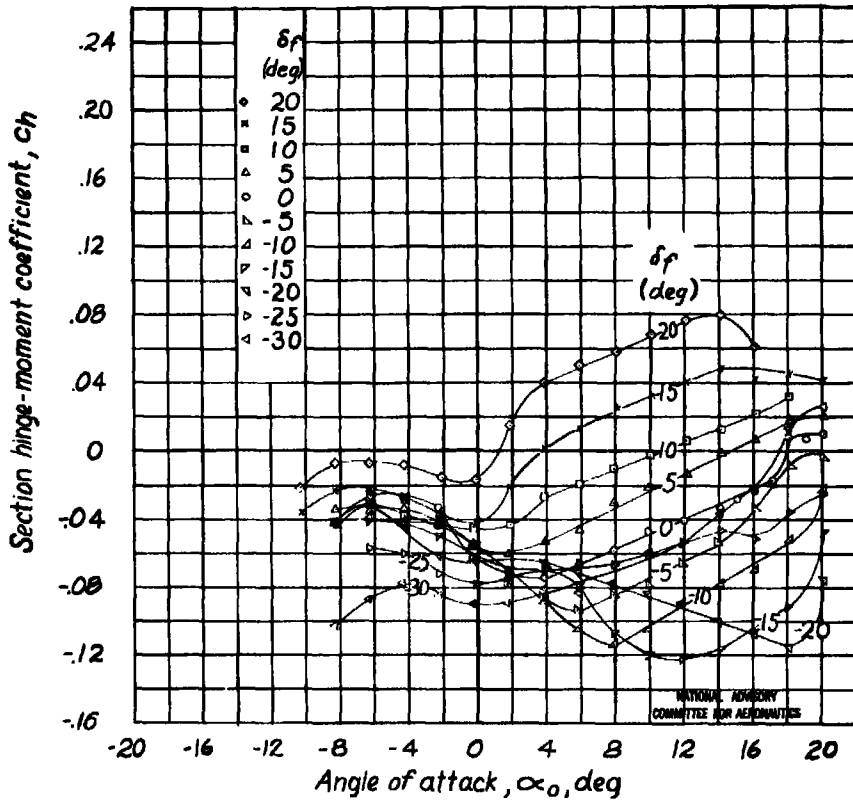

(c) Gaps sealed; $\delta_{t_0} = -15^\circ$; $\partial \delta_t / \partial \delta_f = -0.020$. Concluded.

Figure 11. - Concluded.

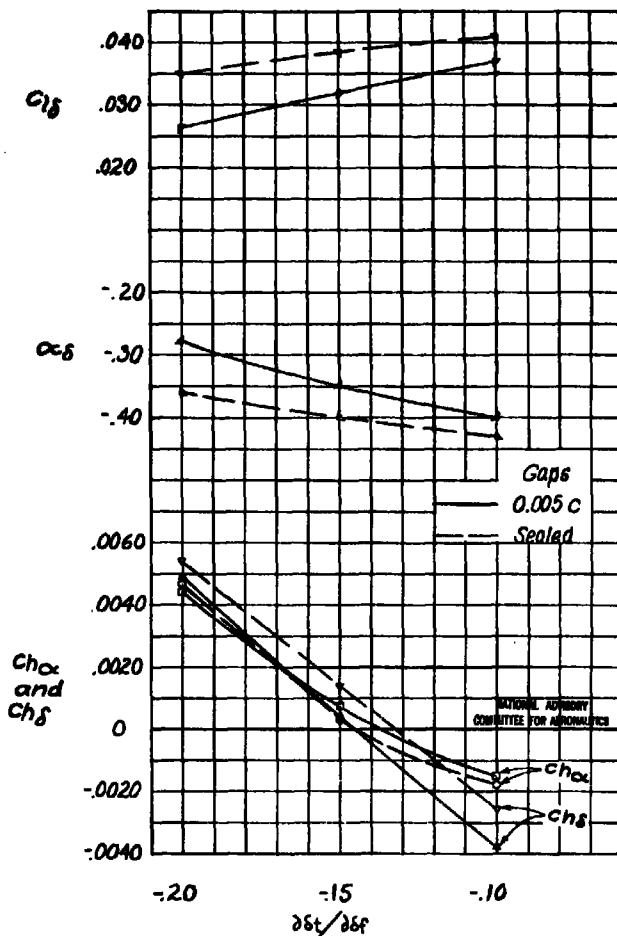

(a) $\delta t_0 = 0^\circ$; gaps open and sealed.

Figure 12. - Variation of parameters with ratio of tab deflection to flap deflection. $c_1 = 0$.

Fig. 12b

NACA ARR No. L5G25

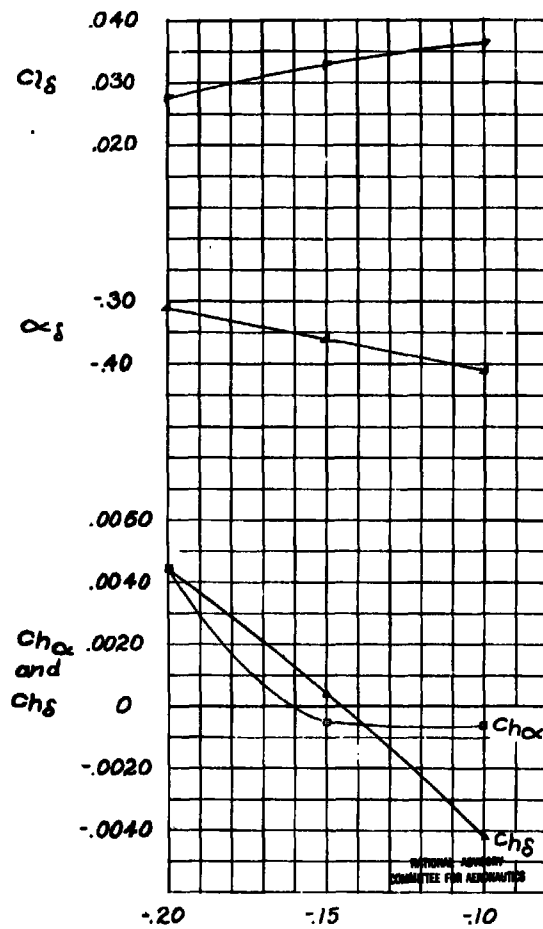

$\frac{\partial \delta_t}{\partial \delta_f}$
 (b) $\delta_{t_0} = -5^\circ$, gaps, 0.005c.
 Figure 12 - Continued.

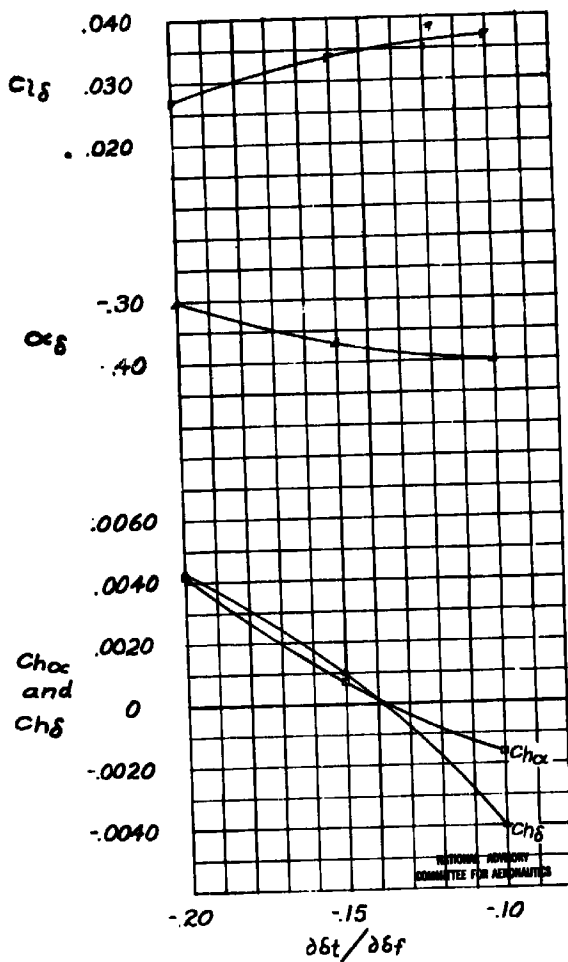

(c) $\delta_t = -10^\circ$; gaps, 0.005c.
 Figure 12. - Continued.

Fig. 12d

NACA ARR No. L5G25

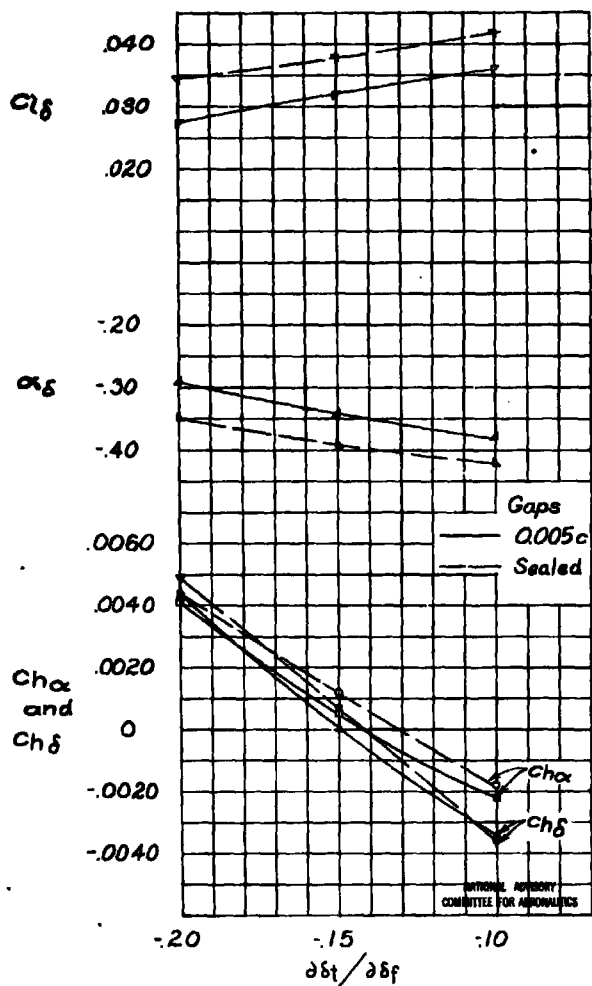

(d) $\delta t_0 = -15^\circ$; gaps open and sealed.
Figure 12. - Concluded.

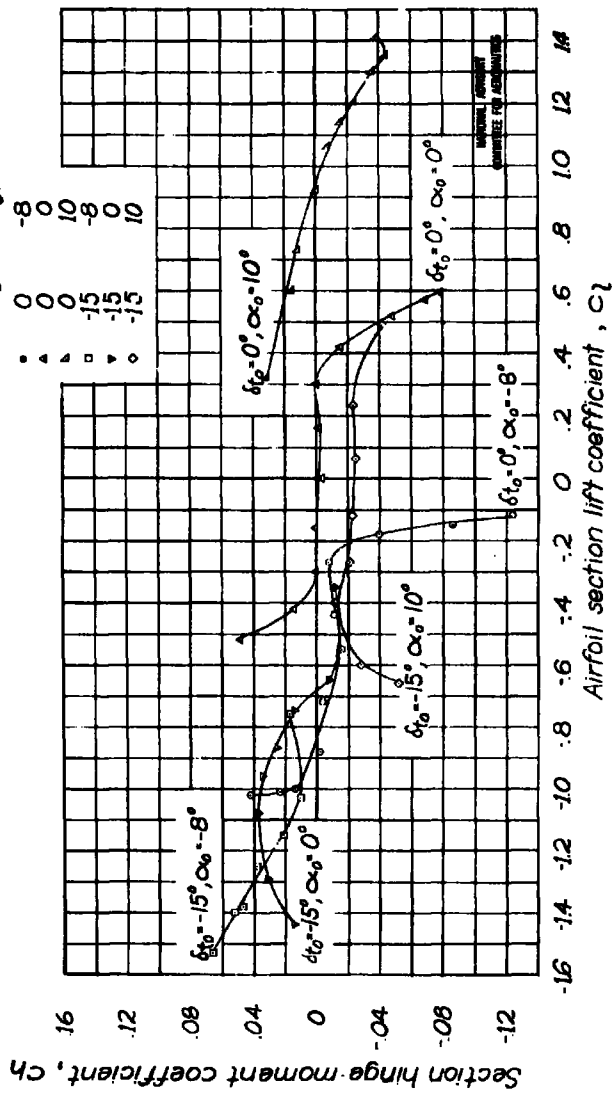

(a) 0.005 c gap.

Figure 13. - Hinge-moment coefficient as a function of lift coefficient for various tab positions and angles of attack for the 2.00c balancing tab on the NACA 0009 airfoil. $\partial \delta_t / \partial \delta_f = -0.15$.

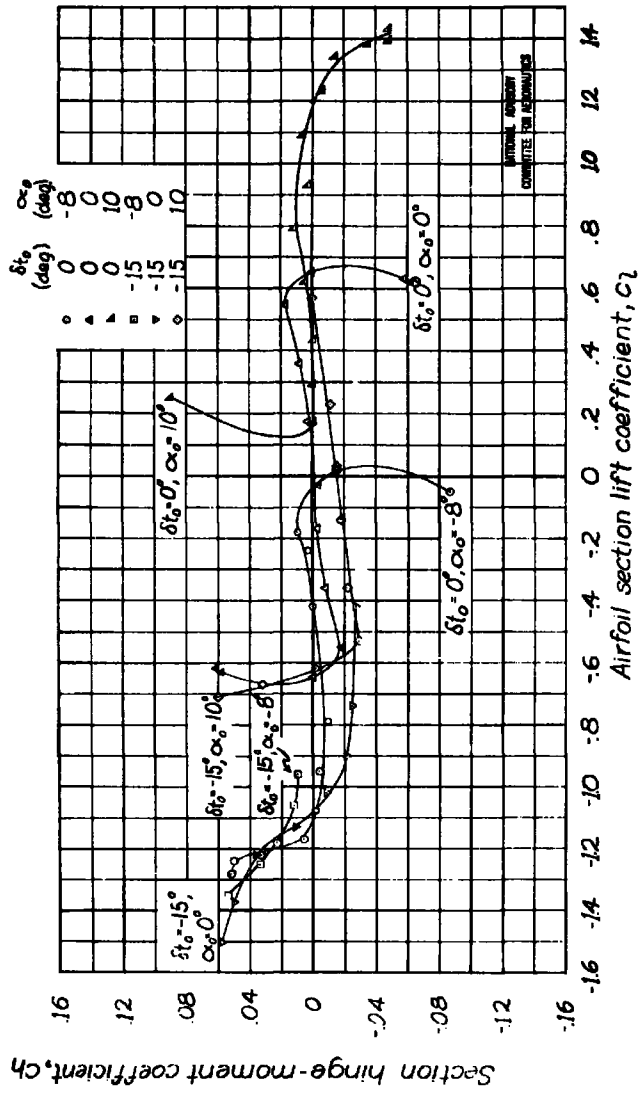

(b) Sealed gap.

Figure 13. - Concluded.

REEL - C

151

A.T.I.

6406

TITLE: Wind-Tunnel Investigation of Control Surface Characteristics XXIII A 0.25 Airfoil -
Chord Flap with Tab Having a Chord Twice the Flap Chord on an NACA 0009 Airfoil
AUTHOR(S): Spearman, M. L.
ORIGINATING AGENCY: National Advisory Committee for Aeronautics, Washington, D. C.
PUBLISHED BY: (Same)

ATI-6406

REVISION

(None)

ORIG. AGENCY NO.

ARR-L5G25

PUBLISHING AGENCY NO

OVER

U

DATE
Sept '45

DOC. CLASS.
Unclass.

COUNTRY
U.S.

LANGUAGE
Eng.

PAGES
58

ILLUSTRATIONS
tables, diagrs, graphs

ABSTRACT:

Airfoils, & Aerodynamic Control Surfaces
P/1
An airfoil was tested which had a 25% chord flap and a 50% chord balancing tab so linked that the tab deflected at given rate with respect to the flap. Tests indicated that flap and tab could be linked to give hinge-moment balance with flap deflection and with angle of attack and yet have greater lift effectiveness than a plain flap of similar size with conventional balancing tab having chord 20% of the flap chord linked to give hinge-moment balance with flap deflection only.

DISTRIBUTION: Request copies of this report only from Originating Agency

DIVISION: Aerodynamics (2)

SECTION: Control Surfaces (3)

SUBJECT HEADINGS: Control surfaces - Aerodynamics
(25600)

1 - (9)
2 - (6-7)

ATI SHEET NO.: R-2-3-17

Air Documents Division, Intelligence Department
Air Materiel Command

AIR TECHNICAL INDEX

Wright-Patterson Air Force Base
Dayton, Ohio

UNCLASSIFIED PER AUTHORITY: INDEX
OF NACA TECHNICAL PUBLICATIONS
DATED 31 DECEMBER 1947.

TITLE: Wind-Tunnel Investigation of Control Surface Characteristics XXIII A 0.25 Airfoil-Chord Flap with Tab Having a Chord Twice the Flap Chord on an NACA 0009 Airfoil

AUTHOR(S): Spearman, M. L.

ORIGINATING AGENCY: National Advisory Committee for Aeronautics, Washington, D. C.

PUBLISHED BY: (Same)

ATI-6406

REVISION

(None)

ORIG. AGENCY NO.

ARR-L5G25

PUBLISHING AGENCY NO

DATE	DOC. CLASS.	COUNTRY	LANGUAGE	PAGES	ILLUSTRATIONS
Sept '45	Unclass.	U.S.	Eng.	58	tables, diagrs, graphs

ABSTRACT:

An airfoil was tested which had a 25% chord flap and a 50% chord balancing tab so linked that the tab deflected at given rate with respect to the flap. Tests indicated that flap and tab could be linked to give hinge-moment balance with flap deflection and with angle of attack and yet have greater lift effectiveness than a plain flap of similar size with conventional balancing tab having chord 20% of the flap chord linked to give hinge-moment balance with flap deflection only.

DISTRIBUTION: Request copies of this report only from Originating Agency

DIVISION: Aerodynamics (2)

SECTION: Control Surfaces (3)

SUBJECT HEADINGS: Control surfaces - Aerodynamics
(25600)

ATI SHEET NO.: R-2-3-17

Air Documents Division, Intelligence Department
Air Materiel Command

AIR TECHNICAL INDEX

Wright-Patterson Air Force Base
Dayton, Ohio

AERODYNAMICS (CONTROL SURFACES)