

UNCLASSIFIED

AD NUMBER

ADA800711

CLASSIFICATION CHANGES

TO: unclassified

FROM: restricted

LIMITATION CHANGES

TO:
Approved for public release; distribution is unlimited.

FROM:
Distribution authorized to DoD only; Foreign Government Information; APR 1946. Other requests shall be referred to British Embassy, 3100 Massachusetts Avenue, NW, Washington, DC 20008.

AUTHORITY

DSTL, AVIA 6/17013, AVIA 6/19332, 19 Oct 2009;
DSTL, AVIA 6/17013, AVIA 6/19332, 19 Oct 2009

THIS PAGE IS UNCLASSIFIED

Reproduction Quality Notice

This document is part of the Air Technical Index [ATI] collection. The ATI collection is over 50 years old and was imaged from roll film. The collection has deteriorated over time and is in poor condition. DTIC has reproduced the best available copy utilizing the most current imaging technology. ATI documents that are partially legible have been included in the DTIC collection due to their historical value.

If you are dissatisfied with this document, please feel free to contact our Directorate of User Services at [703] 767-9066/9068 or DSN 427-9066/9068.

**Do Not Return This Document
To DTIC**

Reproduced by
AIR DOCUMENTS DIVISION



HEADQUARTERS AIR MATERIEL COMMAND

WRIGHT FIELD, DAYTON, OHIO

The
U.S. GOVERNMENT

IS ABSOLVED

FROM ANY LITIGATION WHICH MAY

ENSUE FROM THE CONTRACTORS IN-

FRINGING ON THE FOREIGN PATENT

RIGHTS WHICH MAY BE INVOLVED.

REEL - C

3 4 3

A.T.I.

9 5 2 5

RESTRICTED

RESTRICTED

Class No: 770.34.778.35

R.A.E. Report No. Ph. 1.

April, 1946.

ROYAL AIRCRAFT ESTABLISHMENT, FARNBOROUGH

Suppression of Image Movement in Air Photography

by

W. Romer, D.Tech.Sc., Folland, F.Inst.P.,
F.R.P.S.

R.A.E. Reference:- Ph.458/WR/83.

SUMMARY

The angular velocities of irregular aircraft movement in flight have been measured on flashing light tracks obtained in a camera carried in the aircraft. The R.M.S. angular velocity for average manual flying is 0.0092 rad/sec. with maximum velocities reaching 0.052 rad/sec. With automatic control the R.M.S. values are approximately one third and the maximum velocities one sixth of these figures. By adding the camera vibration movement in the Type 38 mounting a probable R.M.S. velocity of image movement in the camera of 0.0154 rad/sec. is obtained.

Gregory's experimental results on the relation of image movement to resolution are replotted with the object of analysing the part of the function corresponding to small movement values. It is estimated that the effect of movement on resolution is negligible as long as the movement during exposure does not exceed 0.6 of the dimensions of the smallest test-object resolved, without movement, and becomes severe when it is 1.2 or more of that magnitude. This conclusion has been confirmed by an air test.

On the basis of these figures the effect of movement in the present technique is estimated. The possibility of increasing the resolution by increasing the image stability and using very fine grain film is discussed. An increase in resolution by a factor of more than two is considered practicable.

The methods of image movement compensation and of estimation of the required compensation velocity are analysed.

A scheme of stabilisation of the camera as a body freely suspended in neutral equilibrium in the gyroscopic control of the vertical attitude is discussed. A pendulum type anti-vibration suspension is suggested.

The experience obtained in the application of movement compensation in the late war is summarised. Flying experiments applying movement compensation with the gimbal mounting and in a gyro stabilised camera are described, satisfactory agreement with prediction was obtained.

LIST OF CONTENTS

	<u>Page</u>
1 Introduction	4
2 Causes of image movement	4
2.1 Forward movements of the aircraft	5
2.2 Irregular movement of the aircraft	5
2.3 Camera vibration	6
2.4 Addition of movements	6
3 Effect of movement on photographic resolution	8
3.1 Gregory's experimental results	8
3.2 Limits of negligible movement	10
3.3 Confirmation by air test	10
3.4 Effect of movement in the present technique of air photography	11
3.5 Expected advantages of image immobilisation	13
4 Means of image immobilisation	16
4.1 Requirements for different types of air photography	16
4.2 Compensation for forward movement - required accuracy	17
4.3 Methods of compensation for forward movement	18
4.31 Translational image movement in relation to the film	19
4.32 Rotation of the sighting axis of the camera	19
4.4 Application of movement compensation	20
4.41 Comparison of methods of compensation	20
4.42 Compensation in a tilted camera	21
4.43 Timing of camera mechanism	21
4.5 Estimation of the required velocity of compensation	21
4.51 Measurement of ground speed and altitude	22
4.52 Sighting method	22
4.53 Scanning method	23
4.6 Elimination of the irregular movement	24
5 Flying experiments	26
5.1 Experiences and applications in war-time	26
5.2 Experiments aiming at increased resolution	27
5.21 Compensation for forward movement	27
5.22 Gyro stabilisation and movement compensation	30
5.3 Utilisation of the high resolution negative	31
6 Conclusions	32
7 Recommendations	33
8 Acknowledgments	34
References	35
Circulation	37

LIST OF APPENDICES

	<u>Appendix</u>
Measurement of the irregular movements of the aircraft	I
Errors in compensation by means of rotating glass plate	II
Errors in compensation by rocking the camera axis	III
Compensation in a tilted camera	IV
Construction and ground tests of the gyro stabilised camera mounting	V

LIST OF ILLUSTRATIONS

	<u>FIG.</u>
Effect of movement on resolution high contrast	1
Effect of movement on resolution-test object 0.11 density difference	2
movement at right angles to test lines	2
Effect of movement on resolution. Average Results for test lines	3
at 90°, 60°, 30° and 0° to movement for circular image area	3
covering 9° field	4
Effect of movement on resolution air test	4
" " " " " " " "	5
Microfile/SIX resolution ratio	5
Error in movement compensation rotating glass plate and	6
rocking camera	6
Error in movement compensation over the image field	7
Pendulum suspension for the gyro controlled camera mounting	8
(Controls not shown)	8
Improved resolution by movement compensation 20" lens	9
" " " " " " " "	10
" " " " " " " "	11
" " " " " " " "	12
Improved resolution in stabilised camera	13
" " " " " " " "	14
" " " " " " " "	15
" " " " " " " (with Fig. 25 & 26)	16
Results of Air test resolution image angle	17A & B
Frequency distribution of results resolution tests	17A & B
Rotating glass plate	18A & B
Rocking camera	19
Tilted camera	20
Fore and aft tilt	21
Sideways tilt	22
Stabilised camera mounting	23
" " " " - gimbal suspension	24
Track of vibration caused by solenoid action	25
	26

1 Introduction

The characteristic of air photographs which determines their content of intelligible detail is the resolution. It depends on several variables and one which is of significance in air photography is the image movement during exposure.

The usual means of reducing this movement is to shorten the exposure time. This means is limited however, and in cases when velocity of image movement is great, as in large scale photography, the resolution can be considerably improved by reducing the velocity. The advantages obtained in this way is also very significant when insufficient intensity of illumination makes relatively long exposures necessary, for instance in night photography.

The movement of the optical image in the air camera is due to several causes; the forward velocity of the aircraft, the irregular movement of the aircraft in flight and the camera vibration. The factor affecting the resolution is the movement of the optical image in relation to the light sensitive film. In this report the term "IMMOBILISATION OF THE OPTICAL IMAGE" is used in the sense of the reduction of velocity of the optical image in relation to the film without respect to the cause of the movement. It includes therefore compensation for the forward velocity as well as elimination of vibration and stabilisation of the camera in space.

The exposure time is one of the interdependent variables controlling the resolution of the lens-film combination. If due to increased immobility of the optical image longer exposures are allowed the other variables can be modified accordingly, e.g. finer grain film used, and the resolution increased considerably. This increase in resolution is desirable in view of the expected increase in flying altitude and it is obtained without changing substantially the dimensions of the camera. This is of significance in view of the tendencies of development of modern high speed aircraft which are becoming smaller in size. The alternative possibility of using lenses of greater focal length increases the already objectionable size of the camera.

This report summarises the main results of the work done in this country during the late war on image immobilisation. It contains new experimental evidence as well as a discussion of some results published in the papers quoted at the end.

The subject is sub-divided into three main parts, - the causes of image movement, the effect of movement on resolution, including the estimation of gains obtainable by image immobilisation, and the means for image immobilisation. At the end results of flying tests arranged to check some of the conclusions are described.

The applications which have found a successful way into service use relate to rather crude compensation for forward velocity in cases when the blur due to movement was obvious. The research on application of more complete elimination of image movement was not continued as in war time there were no adequate production possibilities for the necessary stabilisation equipment which was required for more urgent needs. Only a "demonstration experiment" has been carried out, and has confirmed the practicability of this avenue for improvement in air photography.

2 Causes of image movement

We can differentiate three main causes of image movement in air photography, the progressive movement of the aircraft, the irregular rotational movements of the aircraft in flight and the vibration of the camera transferred from the air frame.

The velocity of forward movement in the camera will be designated V_f and the corresponding angular velocity of apparent ground movement θ_f .

The angular velocity of rotational (irregular) aircraft movements will be designated θ_1 and vibration velocity θ''_1 .

2.1 Forward movement of the aircraft

The translational movement due to the progressive movement of the aircraft is in many cases the most important of all the causes of image movement.

The velocity of the optical image in the camera due to the movement of the aircraft is

$$V_f = \frac{V_A}{H} F \quad \dots\dots\dots(1)$$

where V_A is the ground speed of the aircraft H its altitude and F the focal length of the lens. Often it is convenient to express this velocity as the angular velocity of the apparent ground movement.

$$\theta_f = \frac{V_A}{H} \quad \dots\dots\dots(2)$$

expressed in radians/sec.

2.2 Irregular movements of the aircraft

On the steady angular velocity due to forward movement of the aircraft are superimposed the varying velocities due to angular movements of the aircraft in flight, about the three axes, i.e. rolling, pitching and yawing. These movements attain high velocities when the aircraft is turning or entering into dive or bank.

During straight and level flight these movements are due to aerodynamic, pilotage, and atmospheric causes. In steady weather conditions they are relatively small and depend largely on the skill of the pilot or on the performance of the automatic controls.

The velocities obtained in steady weather are of particular importance for photographic purposes. These are the usual conditions on clear days, without much cloud, which are suitable for air photography especially at high altitudes.

Measurements of aircraft steadiness were first made by the author by means of a gyroscopic recorder, and extremely low irregular velocities were found (1). The measurements were repeated later on the vibration tracks recorded for the purpose of testing camera mountings as reported elsewhere (2). Much higher figures for the angular velocities were obtained in this way and it is supposed that the accuracy of the gyro recording is not adequate for this purpose.

More flashing light tracks have been obtained since the issue of the note (2). This is described in Appendix I. As justified in para. 2.1 (and App. I) the R.M.S. velocity represents the relevant figure for application in calculations of photographic resolution. The results of these measurements are as follows:

In average conditions of manual straight and level flying in steady weather a R.M.S. angular velocity due to irregular aircraft movements of 0.0092 rad/sec. can be expected. The maximum velocities are more than three times as great.

With careful flying this value can be reduced to 0.005 approx. By using the automatic pilot a further reduction to 0.003 approx. can be expected, and the maximum velocities scarcely twice as great.

2.3 Camera vibration

Further image movements which are to be added to those described above are the rotational components of the camera vibration. These depend on the vibration of the airframe and on the type of camera suspension.

The results of some measurements on camera vibrations in different types of mountings have been reported in (4). These results are repeated in Table I with the addition of the R.M.S. values for angular velocities, which have been calculated from the original experimental figures.

TABLE I

Angular velocities of camera vibration, Wellington aircraft

Exp. No.	Mounting Type	$\bar{\epsilon}_1$	ϵ_1
		Mean rad/sec.	R.M.S. rad/sec.
1	Type 38	0.0070	0.0080
2	" "	0.0090	0.0098
3	Cord suspension, no damping	0.0095	0.0111
4	Cord suspension, friction damping	0.0085	0.0036
5	Cord suspension, critical viscous damping	0.0023	0.0030
6	Gimbal suspension, friction damping	0.0025	0.0031
7	" " " "	0.0038	0.0042
8	" " assymetrical load	0.0042	0.0045
9	Spring mounting friction damping	0.0055	0.0062
10	A.11 mounting	0.0065	0.0073
11	A.11 mounting, friction damping	0.0038	0.0045

The mean $\bar{\epsilon}_1$ figures of 0.0090 rad/sec. for the Type 38 mounting and 0.0042 rad/sec. for the gimbal mounting can be adopted as reasonably safe figures. The corresponding R.M.S. figures are 0.0098 and 0.0045 rad/sec.

These figures were obtained with long focus lens camera (20"). It is usually found that with the short focus lenses the vibrations are higher. For instance with the F.17 camera fitted with 6" lens in A.11 mounting in Lancaster aircraft the mean value of angular velocity $\bar{\epsilon}_1 = 0.025$ and ϵ_1 R.M.S. 0.028 has been found recently. This is however an exceptional case and tracks obtained in Mosquito aircraft with F.52 cameras in Type 38 and gimbal mountings with lenses of 20", 14" and 10" focal length have given results of the same order as in Table I.

2.4 Addition of movements

The effective angular movement of the optical image in the photographic camera is the result of the addition of the three types of movement discussed in the previous paragraphs. One of these is uniform, the two others are irregular oscillatory movements of varying directions and of different characteristic frequencies.

The velocities of these movements will add as vectors and we want to find the R.M.S. velocity of the movements superimposed. When the uniform and oscillatory movements are added and one of them is sufficiently greater than the other the resulting velocity will depend on the greater component only.

In order to estimate the effect of the superimposed uniform and oscillatory movement in cases when both are of the same order of magnitude, we consider the two cases of the directions of the movements parallel and at right angles to each other.

We may suppose that the irregular movement can be approximated by a simple harmonic movement with the velocity equation $\theta = a \sin x$ and the R.M.S. velocity equal c_1

We will thus have

$$c_1 = \frac{\sqrt{\int_0^{2\pi} a^2 \sin^2 x \, dx}}{2\pi} = \sqrt{\frac{a^2}{2}}$$

$$a = c_1 \sqrt{2}$$

When a uniform velocity c_r parallel to the oscillatory movement is added the R.M.S. velocity of the resulting movement will be

$$\theta_s = \frac{\sqrt{\int_0^{2\pi} (\sqrt{2} c_1 \sin x + c_r)^2 \, dx}}{2\pi}$$

$$= \sqrt{c_1^2 + c_r^2}$$

If the velocities are at right angles to each other they simply add as vectors and the resulting R.M.S. velocity

$$\theta_s = \sqrt{c_1^2 + c_r^2} \dots \dots \dots (3)$$

which is the same as with parallel movements.

It can be shown that the same result is obtained at all intermediate angles, and equation (3) represents the general case.

If two irregular movements differing considerably in characteristic frequencies are added the low frequency movement can be considered uniform as compared with the other and the above equation used for calculation of the R.M.S. velocity.

This is the case when considering the camera vibration and the irregular movements of the aircraft. When using the figures given in para. 2.2 and 2.3 we obtain for the standard mounting and average manual flying a probable R.M.S. velocity of image movement of 0.0134 rad/sec.

With gimbal mounting and flying on automatics this figure is reduced to 0.0054 rad/sec. The expected maximum velocities are 2 to 3 times greater.

These results were obtained in steady weather conditions. In "bumpy" weather much higher angular velocities are to be expected.

3 Effect of the movement on photographic resolution

The effect of movement of the optical image during exposure could be included in the characteristics known by the collective name of "light scatter". Under this name we understand all the optical causes preventing the formation of perfect image. When considering the lens in stationary conditions the optical aberrations and wave nature of the light cause the rays emitted from a point source not to intersect in the point predicted by geometry but to "scatter" in a characteristic pattern. Projected onto the diffusing medium of the emulsion the image is expanded and modified in a pattern characteristic for the "lens and emulsion scatter". The movement during exposure causes further expansion and change in the character of the pattern.

This "light scatter" reduces the contrast of small details and makes them invisible on the grainy background of the photographic image. We may expect that the effect of movement will depend upon the character of scatter produced by the lens and film. It is probable however that the character of scatter for different lenses is similar enough to make it possible to find an empirical function of general application relating the resolution to the image movement.

3.1 Gregory's experimental results

Gregory has measured the effect of image movement on resolution using the 20" f/5.6 Aviar lens and SXX film as a representative lens film combination (6). In the analysis of his results (7,8) he found it unnecessary to deal with the initial part of the image movement-resolution function, where the resolution is still largely dependent upon the lens scatter.

The aim of image stabilisation is to reduce the movement to such limits that its effect on resolution would be negligible. Therefore the lowest part of the curve is of special interest.

In order to arrive at a general relation Gregory's experimental results were replotted in a different way. Instead of the resolution its inverse, i.e. the magnitude of the angle resolved is plotted as function of the movement. Both variables are divided by the magnitude of the angle resolved in the stationary image. The relation can be written as follows:

$$\frac{\lambda}{\lambda_L} = f \left(\frac{c}{\lambda_L} \right)$$

where λ is the smallest angle between test lines resolved in the moving image,

λ_L the same in the stationary image, and

$c = ct$ is the angular image movement during exposure. We substitute

$$\frac{\lambda}{\lambda_L} = \lambda \quad (\text{relative magnitude angle resolved}) \text{ and}$$

$$\frac{c}{\lambda_L} = m \quad (\text{relative image movement})$$

λ can be only equal to or greater than unity and we can write the relation:

$$\lambda = 1 + \phi(m) \quad \dots\dots\dots(4)$$

with $\phi(m) = 0$ for $m = 0$

Gregory has measured the effect of movement on resolution for four different lens apertures and three angular separations from the optic axis. The measurements were made on Cobb type test objects with lines at 0° , 30° , 60° and 90° to the direction of movement and for two test contrasts, the high contrast (unspecified) and low contrast of 0.11 density difference. The relative angles resolved calculated from smoothed-out curves drawn through Gregory's experimental points are plotted against relative movements on Figs. 1, 2 and 3. On Fig. 1 the results for high contrast test object for the three angular separations and four apertures are shown for movement at 90° to the test object lines. Fig. 2 shows the same results for the low contrast tests. The points obtained for different apertures are all reasonably well represented by the same curve. The deviations of the experimental points from the common curve do not seem to indicate any systematic trend.

More systematic seem to be the differences in the shape of the curves for varying angular separations from the axis. The toe of the curves is always smaller for greater angles.

Also the shape of curves varies with the test contrast and for low contrast the curves are tangential to the movement axis. For high contrast tests this is less noticeable.

Curves on Fig. 3 are obtained from diagrams averaged by Gregory for all angles between test direction and image movement and for the image area covered by a circle of 90° angle to the optic axis. On these curves the difference between the high contrast and low contrast test is also noticeable.

It would be desirable to extend these measurements to more lenses in order to confirm these conclusions. It would also be necessary to include films of different graininess. From the general theory it would be expected that the effect of decreasing graininess would be comparable with that of increasing test contrast.

The shape of these curves is always definitely concave. Such shape has been predicted by Selwyn on the grounds of a theoretical argument (5) although the experimental results do not confirm his prediction quantitatively.

In order to find some simple power relation for $\phi(m)$ the function

$$\lambda - 1 = \phi(m)$$

is plotted on log log paper. Linear results are obtained for the high contrast test object, with the slope of the lines varying between 1.1 and 1.8 for the three image angles and an average of 1.55. The log graph is not linear for the low contrast test, and the slope increases with decreasing movement. In the lower part of the curve for $1.2 > 0.3$ the slope of the curve varies between 3 and 2. When the average results for all test object directions and a 90° image field are plotted in a similar way, slightly smaller slopes are obtained. For the high contrast tests the slope values vary between 1 and 1.8 and for the low contrast between 1.6 and 2.1 for varying apertures.

In air photography the low contrast details are of great significance and for these we can suppose that the relation expressing the resolution as a function of image movement is sufficiently well approximated by a quadratic function of the shape:

$$\lambda - 1 = v^2 (\pi^2)$$

.....(5)

It is thus justifiable to use the R.L.S. velocity values for estimation of the image movement, as has been suggested in para.3.2.

2. Limits of negligible image movement

In order to estimate what is the greatest allowed image movement during exposure, some arbitrary assumptions about the tolerable reduction in resolution have to be made. For this limiting condition it seems justifiable to consider the case when the effect of movement on resolution is greatest, i.e. with test object lines at right angles to the direction of movement. Also Gregory's curves for test object at right angles appear to be more consistent than the averaged curves.

It is usually supposed that a 10% change in resolution is scarcely noticeable in practice. An increase of the smallest test size resolved by 20% (i.e. reduction in resolution by 17%) for test lines at right angles to the movement direction has been adopted as a limit for the "negligible" reduction in resolution.

On the curves Fig.1 and 2 we find that this reduction in resolution is produced by an image movement varying between 0.5 - 0.8 λ_L according to the test contrast and image angle. It is thought that the adoption of the curve for 90° image angle and low contrast test object (Fig.2) is justified, as representative for average conditions.

The test contrast of 0.11 is expected to be more representative of the detail contrast in aerial photography than high contrast. As concerns the image angle, a great proportion of the area of the F.52 image with 20" lens corresponds to an angle greater than 90°. Supposing that the trend of change of the characteristics with image angle will continue when increasing the angle beyond 90°, the results for 90° will be more representative for the whole image area than the averaged results between 0° - 90°. Finally it is safer to adopt the curve for 90° which is steeper than the two others shown for the low contrast test object. In this way a higher estimate for the required image stability is obtained.

On these assumptions we find that an image movement equal 0.6 λ_L can be allowed before noticeable deterioration of image definition occurs.

On the averaged curves for low contrast a movement of 0.6 λ_L corresponds to an increase in size of test object resolved by 12%.

For a movement twice as great (1.2 λ_L) the size of test object resolved increases by 70% for lines perpendicular to movement and by 45% for the averaged result. This is a very significant reduction in resolution.

3.3 Results of air test

In order to obtain a check on these figures an air test was arranged in such a way that photographs with image movement during exposure equal to 0.6 and 1.2 of the size of test object resolved in the stationary image were compared with photographs obtained with image movement compensation. Two F.52 cameras fitted with 20" Aviar lenses were carried in a Wellington aircraft flying at an altitude of 6500' and 3250' and ground speed of 200 m.p.h. The lenses were used at 1/5.6 and 1/400 sec. shutter setting. In these conditions the irregular movement is negligible. Photographs of the R.A.E. test object were taken using a standard magazine and a moving film magazine. 12 photographs of the test object were obtained. After 6 photographs the magazines were interchanged on the cameras so as to eliminate the possible effect of difference in lens resolution.

The mean difference in the number of test-groups resolved when comparing the negatives with movement equal $0.6 \lambda_L$ and no movement, assessed by 6 observers, is 0.41 groups. This corresponds to an increase in size of the test object resolved by 11%. In the centre of the field (angular separation from axis less than 30°) the mean difference of 0.72 groups has been found from 4 test photographs, corresponding to an increase in test size of 18%. Thus the agreement with the prediction is good.

It was not possible to assess the difference in resolution in the photographs with movement equal $1.2 \lambda_L$ as all the test objects were resolved on all the photographs.

In Fig.4 two pairs of photographs showing the effect of movement equal to $0.6 \lambda_L$ are reproduced. The difference in resolution is just noticeable. Fig.5 shows the significant effect on resolution caused by movement equal $1.2 \lambda_L$.

It is concluded that the movement equal $0.6 \lambda_L$ can be well adopted as limiting movement value.

It is expected that the extension of this limiting value of movement to similar types of lenses of different focal length should be allowed. In view of the difference in shape of the movement test object size relation with the change of test object contrast it is thought that considerable change in graininess may affect it. Therefore the value arrived at should not be extended to fine grain emulsions. As no experimental information for fine grain emulsions is available however the same value has been used in all the arguments in this report as a first approximation. It is expected that the error introduced by this assumption would never be greater than 2 : 1.

The general concave shape of the image movement test object size relation is confirmed broadly by practical experience with image movement compensation. It has been shown that the reduction of excessive image movement has a very great effect on resolution and when approaching perfect compensation the effect becomes small. This makes great accuracy in compensation unnecessary.

3.4 Effect of movement in the present technique of air photography

On the basis of the above evidence an attempt is made to evaluate the effect of image movement on resolution in a few practical examples of air photography. The mean angular resolutions over the field of an F.52 camera for representative lenses used in reconnaissance photography are given in the following table:- (test object contrast = 0.2)

/Table

TABLE II
Resolution of lenses

	F/6.3 lin./rad.*	F/8 lin./rad.	F/11 lin./rad.
Ross 20" F/6.3 Survey lens (9)	4050	5100	6000
T.T.H. 20" F/5.6 Aviar lens(10)	(F/5.6) 5800	"	"
Ross 20" F/6.3 Survey (proto- type) (11)	8600	9200	9350
Booth 36" Ross No. 158073 F/6.3 Telephoto (12)	8600	9000	9900
Wray 36" F/6.3 prototype (13)	11000	13000	14000

At F/11 we can adopt for the lenses at present in service a mean angular resolution of 6000 lin./rad. for the 20" lens and 10000 lin./rad. for 36" lens. We may expect that in the future the respective figures will be 10000 for 20" and 14000" for 36" lens.

Therefore $0.6 \lambda_l$ i.e. the maximum movement during exposure which would not seriously affect the resolution with the lenses in use at present is 0.0001 rad. and 0.00006 rad. for the 20" and 36" lenses.

$\frac{0.6 \lambda_l}{t_E}$ is the corresponding angular velocity, where t_E is the shutter time. With 1/400 sec. shutter time this corresponds to 0.040 and 0.024 rad/sec. angular velocity.

When adding the forward velocity to the irregular movement we calculate using formula (3) that in an aircraft flying at 250 m.p.h. the effect of movement on resolution will become noticeable below an altitude of 18000' with the 36" lens and 9500 with the 20" lens. If no vibration was present these altitudes would be 15000' with the 36" lens and 9000 with the 20" lens at F/11.

The severe effect of movement as shown on Fig.5 should appear at 7500' and 4500' with the two lenses respectively.

* The term "resolution" is much used and although in recent years great progress has been made in the definition of this complicated quantity, some confusion seems to have arisen in the nomenclature in its application to air photography. The resolution of a photographic material is usually expressed as the number of resolvable lines per millimetre. The same measure is sometimes used for lens-film combinations, but it is convenient to use angular measure in this case. If R is the resolution on the negative in lines per mm. and F the focal length of the lens in mm. $1/RF$ is the angle resolved measured in radians (supposing $1/R$ small as compared with F). The inverse value RF represents therefore the number of lines resolved per unit angle. Toarle calls this the ground resolution and this name has been adopted by some other authors. This term is a little confusing and it is suggested that RF should be called the angular resolution and measured in lines/Rad. in analogy to linear resolution in lines/mm. The term ground resolution should be reserved for resolution in ground scale. Usually this is expressed as the magnitude of the detail resolved on the ground i.e. $\frac{H}{M}$ where H is the aircraft altitude.

All these altitudes will increase with the lens resolution and the ground speed of the aircraft. With a ground speed of 500 m.p.h. and the new 36" lens a severe reduction in resolution will be caused at an altitude of 23,000' and the effect of image movement will be still noticeable up to 68000', supposing that the vibration and aircraft steadiness remain unchanged. If no vibration was present these altitudes would be 43000' and 22500'. As another example the K.19 camera with 12" lens F/2.5 is taken. Here it is more difficult to make an approximate estimation as there are no comparable figures for the resolution of the lens-film combination available.

It is also not easy to decide what picture area should be adopted for calculation of the mean resolution, as in night photography the whole area is not usually sufficiently illuminated and therefore should not be taken into consideration. Tearle has measured resolution of the lens used in this camera with SXK film (15) and a mean angular resolution of 1800 lines/rad. appears to be a fair guess based on his figures and taking account of the difference in resolution between TriX and SXK films. On ground of this figure a maximum negligible image velocity with the K.19 camera is 0.033 rad/sec. with 1/100, and 0.0083 rad/sec. with 1/25 sec. shutter setting is obtained.

The optimum conditions for use of this camera with the Mc.II flash are at an altitude of 4500' with 1/100 sec. shutter setting (5). With an aircraft travelling at 250 m.p.h. the movement during exposure 1.45λ_g is obtained and thus the effect of movement will be severe. The effect of movement will further increase rapidly when reducing or increasing the flying altitude. Similar examples could be given for the "open-plate" night camera, where the effect of movement is still much greater.

When calculating the effect of movement for a given short shutter time to a first approximation only we may omit the effect of irregular camera movements and also (for a limited range of focal lengths) suppose the angular resolution to be proportional to focal length. We will then find the effect of movement to depend only on aircraft speed and image scale. At 250 m.p.h. and 1/400 sec. shutter setting the effect will begin to be severe at a scale of 1 : 2500 and increase rapidly with the scale.

3.5 Expected advantages of image immobilisation

In the preceding paragraphs an attempt has been made to estimate the limiting conditions when the image movement begins to affect the resolution adversely. The curves in Fig. 3 allow the calculation of the loss in resolution in each particular case. Few given examples show when these conditions occur in practice. The general conclusions are that with the techniques at present in use in day photography the movement affects the resolution of the lens-film combination only in large scale photography. In night photography with pyrotechnic flashes the effect of movement is always severe.

In all cases when in present technique the movement reduces the image definition immobilisation will allow attainment of the full resolution of the lens-film combination. This however is not the only possible application of image immobilisation. Further improvement can be obtained with the use of different films and different exposure times from those used in present practice.

The resolution of air photographs depends on the lens-film light scatter, the graininess of the emulsion, and the movement during exposure, which as we have seen before also affects the "scatter".

Supposing a given velocity of the optical image movement, all these elements are interdependent and we cannot alter one of them without altering the others. For instance if we try to reduce the graininess this can be achieved in general only by using a film of lower speed and an alteration of the lens aperture or exposure time will be required. The change of lens aperture will affect the light scatter and the change of exposure time the movement during exposure, and so changes the effective light scatter in another way.

The values of shutter speed, lens aperture and film graininess adopted in present practice are compromise values which in the prevailing velocities of image movement have been found to give the best possible resolution.

Improvement in any of these elements - for instance increasing the film speed without changing its graininess - will allow us the adoption of different compromise values for the two other elements and to obtain an improvement in resolution. Reduction of image velocity will allow longer exposures and improvement in resolution of the lens-film combination by either reducing the light scatter or the graininess or both.

The image stability required in order to obtain a certain gain in resolution can be estimated using the statistical relations worked out by the Kodak Research Laboratory at Harrow. According to Toarle (16) the angular resolution of the lens-film combination is represented by the formula:

$$R = K' \frac{(F/No)^{0.3}}{G^{0.5}}$$

where G is the film graininess, F/No the stop number of the lens, and K' the proportionality factor.

On the other hand the graininess of the emulsions according to a similar empirical relation (17), is proportional to the cube root of the film speed. Thus when changing the film graininess the relation between resolution and exposure time t_E is expressed by the equation

$$t_E = K'' R^6$$

The maximum negligible movement during exposure is inversely proportional to the resolution

$$m = \frac{K'''}{R}$$

and the maximum negligible angular image velocity

$$v = \frac{m}{t_E} = \frac{C'}{R^7}, \quad R = \sqrt[7]{\frac{C'}{v}} \quad \dots\dots\dots(6)$$

where C' is the new constant including K' , K'' and K''' .

By similar reasoning we find that when changing the lens aperture the maximum negligible image velocity is

$$v = \frac{C''}{R^{7.7}} \quad \dots\dots\dots(7)$$

From this we find that doubling the resolution by using finer grain film would require the increase of exposure time 64 times and an increase of image stability by a factor of 128 times. The maximum allowable angular velocity to obtain this result with the 36" telephoto lens is 0.00019 rad/sec.

These are statistical formulae and in individual cases better performance may be obtained. The results however obtainable when replacing SXX with microfilm agree reasonably well with this prediction.

The resolution used in this formula is the mean resolution over the whole image field. The gain in resolution due to reduction in graininess depends upon the pattern of light distribution of point images produced by the lens and usually it changes considerably with the lens aperture, angular separation from axis, and also with the lens type.

In order to show this the ratios of resolution $\frac{R_{\text{Microfilm}}}{R_{\text{SXX}}}$ calculated from measurements made by Tearle (18) (19) (20), are plotted in Fig.6. These ratios are plotted against (image) separation from the optic axis, for different lens apertures. Because of the scatter of the points, it was not possible to draw separate curves for each aperture and common curves for two higher and two lower apertures are drawn.

The gain in resolution is consistently higher near the axis than for large field angles and also increases with decreasing lens aperture. In general the gain is greater when the lens scatter is smaller. The mean resolution ratios are indicated on Fig.6 calculated from the curves for different lens apertures. According to the empirical relation the gain should be 1 : 2.4 which agrees reasonably well with the figures obtained for small apertures.

In view of these different results obtained for different lenses it is of interest to test the new improved lenses now coming into production (11) (13) for their resolution with fine grain film.

In order to judge the value of this method of increasing the resolution it should be compared with other ways of obtaining this aim. The method generally adopted up to date has been to increase the focal length of the lenses. It is known that the angular resolution increases at a slower rate than the focal length. According to Tearle's relation (16) the angular resolution increases in proportion to the square root of the focal length and doubling the resolution of the present 36" lens would require a lens of approximately 150" focal length if the formula can be extrapolated to such an extent. It is probable that still greater increase in focal length would be necessary.

Increase in resolution without significantly increasing the size of the camera is of special value in view of the tendency of modern aircraft to become smaller.

The disadvantage of this method however is the small size of the image obtained, requiring a new development of the viewing and interpreting technique.

In night photography the pyrotechnic flash is still the most powerful light source available, permitting high altitude application. Also in low altitude its use will probably remain widespread.

The light output is however always the most critical factor affecting the resolution, quality (suppression of haze effect) and altitude range. Also the flash duration is relatively long. Despite the use of shutters reducing the total exposure at least by half (3) (14) the effect of movement is always serious and a significant improvement would be obtained by image immobilisation. But further advantages could be obtained if adequate immobilisation is realised allowing the full duration and thus the full light output of the flash to be utilised.

It seems reasonable to expect that in this case the present altitude range could be increased by 2 and at the same time the full resolution of the present lens film combination obtained, or alternatively a lens film combination of twice as great resolution used to its full advantage. Such a great gain in resolution can be obtained by a simultaneous increase in focal length and reduction in aperture. The increase in focal length is practicable when the relative aperture is reduced.

4 Means of image immobilisation

4.1 Requirements for different types of air photography

The movement of the optical image in the camera is a result of several factors and each of them must be suppressed by different means.

The translational movement of the image cannot be eliminated as it is the necessary consequence of the forward velocity of the aircraft. However it can be compensated for as it is regular and predictable.

The irregular movements deriving from engine vibrations and aircraft unsteadiness must be eliminated. Despite their different origins they are similar in shape but differ in characteristic frequencies and a common treatment of them is possible.

The image velocities due to these causes vary within wide limits and the necessity of suppressing the different movements depends on the maximum velocities allowed in different applications of air photography. These have been calculated in para. 3 and are shown in Table III.

TABLE III

Negligible image velocities in air photography

	Type of Photography	Maximum negligible image velocity
1	Day photography 36" lens F/11 1/400 sec. SXX film	0.021 rad/sec.
2	" " new 36" "(15) F/11 1/400 sec. "	0.017 "
3	Night " 12" F/2.5 lens 1/100 sec. TriX "	0.033 "
4	" " " 1/25 " " "	0.0083 "
5	" " 25" F/4.5 lens 1/10 sec. TriX " (open plate,	0.0015 "
6	Day photo 36" F/11 0.16 sec. Microfilm film.	0.00019 "

Compared with this the velocity due to the added effect of aircraft instability and camera vibration is with (para. 2.4)

Average manual flying, standard camera mounting. } 0.0134 rad/sec.

Flying on automatics global mounting. } 0.0054 rad/sec.

The velocity due to forward movement varies within wide limits but for most operational conditions it is much higher than that due to irregular movements.

By comparing these figures we find that the velocity allowed in day photography is always greater than that due to irregular movements

in average flying conditions. The same applies to night photography with a fast shutter setting.

This means that in these cases it is sufficient to suppress the forward movement in order to obtain the full performance of the lens-film combination. In night photography with a 1/25 sec. shutter setting improved mounting and flying stability is necessary in addition to the compensation for forward movement in order to eliminate the effect of movement. In the cases of high resolution open plate night photography and high resolution day photography with fine grain film, (Table III, 5 & 6) the irregular movements must be eliminated far more completely than was possible until recently in order to obtain the expected performance.

4.2 Compensation for forward movement - required accuracy

In order to suppress the effect of forward movement we must predict or measure its rate and compensate for it. Both can be done in different ways and the device will depend on the required accuracy which has to be analysed first. It is determined by the requirement that the resolution of the lens-film combination should not be affected by the movement.

If however for technical reasons we decide to suppress the effect of forward movement only in cases when the irregular velocity is so great that it already affects the resolution, the forward velocity should be limited to such an extent that it would not appreciably affect the velocity when added to the irregular movement.

In both cases it is convenient to express the allowed error in compensation as a fraction of the uncompensated velocity.

In the first case the allowed velocity is $0.6 \lambda_T / t_E$. This should be equal to the R.A.S. velocity obtained by adding the irregular velocity and the permissible error in compensation which we will call ϵ_0 . Thus

$$\theta_0 = \sqrt{(0.6 \lambda_T / t_E)^2 - \theta_1^2}$$

$$\text{and } \epsilon_0 \% = \frac{H}{V_A} \sqrt{\left(\frac{0.6 \lambda_T}{t_E}\right)^2 - \theta_1^2} \times 100 \dots (8)$$

When the irregular movement is negligible this becomes

$$\epsilon_0 = 100 \frac{H \cdot 0.6 \lambda_T}{V_A \cdot t_E}$$

This means the permissible error is equal to 100×0.6 of the detail magnitude resolved by the stationary lens in the ground scale divided by the distance travelled by the aircraft during the exposure time. In cases when the differences in ground resolution due to application of different lenses can be neglected it will be in the first approximation inversely proportional to the image scale, aircraft speed and shutter time.

In the second case, when the irregular movement controls the resolution we may adopt arbitrarily the condition that the R.A.S. velocity resulting from adding these movements should not be affected by more than 20% by the uniform component. This will affect the average resolution by approximately 5-15%, according to the magnitude of the irregular component, as can be seen from the curve Fig. 3b. It would be more correct to adopt an arbitrary value for the reduction in resolution. In view of the approximate value of all the calculations it is thought this complication is not justified.

From the equation (3) para. 2.4 it is found that the R.M.S. velocity of the resultant motion is increased by 20% when the forward velocity is 0.65 of the irregular velocity.

We will thus have

$$\theta_e \% = 0.65 \theta_i H/V_A \cdot 100 \dots\dots\dots(9)$$

The following examples may serve as an illustration of the order of accuracy in compensation required in practice.

Supposing a day camera with 56" lens of F/11 and 1/400 sec. shutter time in an aircraft flying at 250 m.p.h. at 5000' altitude we find from formula (8) the allowed error $\pm 25\%$.

In the night camera with 12" 1/2.5 lens and 1/25 sec. shutter time in an aircraft flying at 500 m.p.h. at 7000' altitude the allowed error $\pm 8\%$ is found using formula (9).

In both cases the R.M.S. irregular velocity of 0.0134 rad/sec. has been supposed.

The required accuracy is much greater in the case of a stabilised camera with fine grain film.

Taking the same 56" lens in the aircraft flying at the same speed but at 4000' altitude and using a fine grain film which would give twice the resolution of the standard film - the allowed error in compensation is only $\pm 2\%$.

It is thus impossible to draw any figures generally applicable for the required accuracy in image movement compensation. They can, however, be calculated for each particular case.

In the above reasoning the requirement of the full utilisation of the potential resolving power of the lens/film combination has been adopted. The required image definition is an independent factor. Often much lower resolution will be adequate, especially if low altitude flying has been adopted for strategical reasons rather than for considerations of ground resolution.

The attainable accuracy in movement compensation may be limited by the accuracy of the methods adopted and by the accuracy of estimation of the required compensation velocity. Both these factors are discussed in the following paragraphs.

4.3 Methods of compensation for the forward movement

The effect of the forward velocity of the aircraft on the optical image in the camera can be compensated by introducing a suitable movement in the camera mechanism. The aim of this compensation is to immobilise the optical image in relation to the sensitive film.

The compensation can be obtained in two different ways:-

- (a) The optical image is moved parallel to itself or the film is moved in its plane at such a rate and in such a direction as to provide immobility of the image in relation to the film.
- (b) The sighting axis of the camera is rotated in such a way that the principal point of the camera has the same object point projected on it throughout the exposure.

Both principles can be applied in different ways, by means of purely mechanical or optical aids. The translational movement of the image in relation to the film can for instance be obtained mechanically by moving the lens or the film during the exposure, or optically, by rotating a glass plate arranged between the lens and the focal plans.

The angular movement of the sighting axis is obtained by rocking the camera or by rotating a mirror or prism, or a combination of mirrors or prisms in the external path of the light entering the camera lens.

4.31 Translational image movement in relation to the film

The principle of the parallel movement of the image in relation to the film is geometrically correct. Supposing the camera axis vertical and the ground plane horizontal the image will be geometrically similar to the object. The image velocity due to aircraft movement will be the same in every point of the image and will be fully compensated by parallel movement. The only errors will be those due to lens distortion or to the inaccurate fulfilment of the geometrical condition.

The parallel movement of the optical image in relation to the film can be obtained mechanically, by moving the lens or the film translationally. This does not introduce any errors in principle.

When employing the optical method of a rotating glass-plate we find that the rate of image movement is not uniform over the field. Supposing the compensation to be correct on the axis, the error is a function of the angular separation from the axis and of the index of refraction of the glass, as shown in Appendix II. In a line passing through the principal point of the image in the direction of flight the error expressed in % of the uncompensated velocity is

$$E_s = \left(\frac{1}{\mu - 1} - \frac{\mu(\mu^2 \cos^2 \alpha \sin^4 \alpha)}{(\mu - 1) \cos \alpha (\mu^2 - \sin^2 \alpha)^{3/2}} \right) \cdot 100 \quad \dots\dots(10)$$

where α is the angular separation from optic axis and μ the index of refraction of the glass.

On Fig. 7* the error is plotted against the angular separation from the axis for $\mu = 1.52$ (full line).

4.32 Rotation of the sighting axis of the camera

By rotating the sighting axis of the camera perfect compensation of the image movement can be obtained only on a line passing through the principal point of the photograph parallel to the axis of rotation.

As shown in Appendix III the errors in compensation in other points of the image, supposing the camera vertical at the moment of exposure, can be calculated from the following formula:

$$E_s = 100 \left[\frac{X^4}{H^4} + \frac{X^2 Y^2}{(X^2 + H^2)^2} \right] \quad \dots\dots(11)$$

X and Y are the coordinates of the point in the ground plane with respect of the trace of the camera axis as origin and the X axis parallel to the line of flight. H is the aircraft altitude.

* Together with Fig. 16.

The error for $Y = 0$ is recalculated for angular separation and plotted on Fig.7 as an interrupted line. It is smaller than the error obtained when using the rotating glass plate.

On Fig.8 the lines of equal error are shown on the field covered by a 9" x 9" camera fitted with a 6" lens. On the same drawing the field covered by an F.24 camera fitted with an 8" lens and on an F.52 camera fitted with a 20" and a 36" lens is indicated.

4.4 Application of movement compensation

4.4.1 Comparison of methods of compensation

When comparing the allowable error in compensation with the errors caused by the different methods of compensation we arrive at the conclusion that for most of the applications of compensation using high speed film, i.e. for low altitude photography and for night photography, all the methods discussed give sufficiently accurate results with narrow angle lenses. This applies to the F.52 camera with 20" and 36" lens.

With lenses covering an angle of 35° or more the errors in compensation when using either the rotating plate or the rocking method are beginning to be significant. For instance, for the F.24 camera fitted with 8" lens the error at the edge is 10% when the rocking method is used and 15% with a rotating glass plate. This would still not be excessive for most of the applications supposing that the compensation movement is so adjusted that the error is divided with an undercompensation on the axis and overcompensation at the edges.

For wide angle cameras both of these methods give excessive errors. For instance for a 9" x 9" camera fitted with a 6" lens the error at the edge is more than 75% with the rotating plate and more than 50% with the rocking camera.

For photography with a highly stabilised camera and fine grain film both of these methods can be used only for narrow angle photography, e.g. for the F.52 camera with a 36" or longer focal length lens.

The methods of moving the lens or the film are free from any systematic errors and convenient for mechanical solutions. The method of moving the film has the advantage of continuous compensation which is significant when it is not possible to predict exactly the moment of exposure as in night photography using pyrotechnic flashes.

An elegant construction using the moving film principle is the slit camera in which the film is passed behind a narrow slit which replaces the shutter. The exposure time is determined by the slit width and the speed of the film movement.

This method has been found very successful in low and very low altitude photography with wide angle lenses. At higher altitudes using longer focal length lenses image distortions due to the camera vibration and irregular movements of the aircraft become very apparent. Further difficulties are caused by the necessity of using very narrow slits because of the slow rate of film movement.

Both these difficulties will disappear when using a stabilised camera and fine-grain low-speed film. Supposing that the slit is intersecting the lens axis, the advantage of this scheme is that a greater proportion of the picture area is produced by the central part of the

lens. This is of significance when using the fine grain film as in this case the resolution is dropping off very much more rapidly with angular separation from the axis than with the high speed film. The gain in resolution, due to employing fine grain film when using this arrangement will thus be greater than calculated in para. 3.5.

A disadvantage of the film moving method is that it is necessary to stress the film mechanically during exposure in order to overcome the friction. This is likely to introduce differential distortion of the film during exposure which may be of significance in survey photography. It is thought however that the necessary friction can be reduced by appropriate camera design to such an extent that the elastic distortion of the film would be negligible.

The method of moving the lens is free from this disadvantage and is also convenient for elegant mechanical solutions with the lens movement coupled with the action of the inter-lens shutter.

In this case however the lens movement must be correlated with the shutter action in order to allow exact determination of the lens position during exposure.

4.4.2 Compensation in a tilted camera

It is often necessary to tilt the camera axis so that it is no more at right angles to the ground plane e.g. cameras tilted sideways are used in order to increase the ground cover. Rear tilt is used in night photography to bring the best illuminated part of the ground in the camera field.

In those cases the rate of image movement is changed as compared with the vertical camera and becomes not uniform over the field as discussed in Appendix IV. From the graphs accompanying the appendix it can be seen that movement compensation can be still used with advantage at considerable tilts. For instance in a F.24 camera fitted with 8" lens the error at the edges reaches 50% and the movement can still be reduced to half its value without compensation at a fore and aft tilt of 40° .

With the F.52 camera fitted with 36" lens and with sideways tilt the same condition is obtained at 77° angle of tilt.

If high accuracy in compensation is required the allowed margin for tilt angles is narrower but is not becoming exceedingly small. With F.52 camera with a 36" lens and an allowed error of 2% at the edge a maximum fore and aft tilt of 6° or sideways tilt of 10° is permissible.

4.4.3 Timing of the camera mechanism

With the conventional camera types taking exposures periodically at time intervals calculated so as to give the desired overlap of pictures, the time interval between exposures is inversely proportional to the image velocity in the camera. The mechanism controlling the compensation velocity can thus be designed to control the timing of the camera cycle, and replace the timing controls used at present. This applies to all the methods of compensation for progressive movement.

4.5 Estimation of the required velocity of compensation

The angular velocity of compensation movement necessary to compensate for the image movement can either be calculated from the

information given by the navigation instruments or can be measured directly by means of a sighting or ground scanning device.

Besides the velocity the actual direction of movement in relation to the aircraft axis, resulting from the aircraft movement and wind vector must be determined.

4.51 Measurement of ground speed and altitude

The information necessary to calculate the compensation velocity is the ground velocity vector and the altitude above the ground level. The most usual methods of measuring the required magnitudes in the aircraft are to measure the static air pressure (altimeter) the dynamic pressure (indicated air speed), and air temperature. The further information required is the wind vector. This is the one most likely to introduce error. From the experience of R.A.F. Squadrons using the Mk.14 bombsight it is estimated that when the wind vector is determined near the target by means of the Air Position Indicator, an overall accuracy of the angular velocity determination of $\pm 3\%$ can be expected.

If the information on wind vector given by the meteorological service is used errors of 25 m.p.h. are quite likely, and an overall error of $\pm 10\%$ should be expected with the present air speeds. If the target altitude over sea level is not known the relative errors may increase considerably, especially at low altitudes.

From these considerations it can be concluded that the calculation of compensation velocity from manometric altitude and air speed measurements gives results of adequate accuracy for most applications of image movement compensation. It is suitable for adaptation for automatic control. Its disadvantage is the problem of finding the wind vector and the inaccuracy in the case of varying ground height in the target area. The last cause makes the method of little use for low altitude photography in cases of uneven ground.

Much more reliable results in this respect are obtained by means of the radio altimeter which gives the altitude above ground level. There are also possibilities of measuring directly the ground speed and direction by means of radar methods, and feeding the information into a control. Both these methods are in development and will not be discussed here in detail. By getting over the difficulty caused by the wind vector determination, and the need to allow for ground altitude, these methods promise to be much simpler and reliable than the methods based on manometric measurement. The advantage of all these methods is that they can be used at night as well as in day time.

4.52 Sighting method

The sighting method gives quickly accurate information on the magnitude and direction of the apparent image movement.

It is estimated that the effective accuracy of the S.A.B.S. bombsight which is based on this principle is 0.5%.

It is thought that for the purpose of image movement compensation it will be convenient to arrange the sighting device in such a way that the correct compensation could be estimated at a glance or in the course of a few seconds and not as a result of a relatively long run as with a bombsight. Measurements have thus been made on the visibility of image movement in the field of a sighting telescope provided with a graticule.

It has been found when observing the moving pattern of the aerial photograph without magnification that a rate of movement of 0.0009 rad/sec. can be detected in a few seconds under good conditions of observation. A movement twice as great is easily seen in an observation of approximately 1 sec. duration.

This means that in order to obtain the accuracy of 0.00019 rad/sec. necessary when using microfilm with a 36" lens (para. 4.1) a magnification of approximately 5X and preferably 10X would be necessary in the sighting telescope. More experience is still required to decide the best magnification as it is more convenient to use a wide angle sight, providing a greater chance of finding prominent ground detail on which to observe the movement.

The sighting method besides being accurate is also simple, and certainly it is advised for experimental purposes. Its disadvantage is that it can not be developed into a fully automatic method.

It is thought that a device stopping the image in the field of sight for a reasonably long time (5-10 sec. for convenient observation) is preferable to a sight with both image and graticule travelling across the field at the same rate. In this latter case the magnification of the sight would be of less advantage as it will reduce the duration of observation in the same proportion as the movement velocity is increased.

4.53 Scanning method

When the optical image of a bright moving object is projected upon a grid of transparent and opaque lines with a photoelectric cell arranged behind it a fluctuating current is produced. The frequency of fluctuation is proportional to the velocity of the movement and the number of grid lines per unit length and can be used for measuring the velocity (23).

If instead of a single object the whole image projected on the grid is moving, e.g. the ground image seen from the aircraft, similar current fluctuations are obtained because of the differences in brightness of the image detail. Supposing the transparent lines of width a separated by opaque lines of the same width, now detail will appear in the transparent lines as long as the movement is smaller than a and the total flux transmitted by the grid will vary at random. For a movement equal to $2a$ however, the same detail as at the beginning will be projected on the transparent lines, shifted by one line spacing with the exception of the first line where new detail will have appeared. The flux transmitted will be nearly the same as at the beginning.

The phase and amplitude of this cyclical flux change will vary slowly at random as new detail appears on the grid resulting in a signal characterised by a band of frequencies. The width of this frequency band which determines the accuracy of velocity measurement depends on the number of lines in the grid.

The principle described has been applied in the Automatic Film Speed synchroniser, built for the Scano strip camera. The device applies a simplified optical system with the lens replaced by a grid (24).

This device is fully automatic and controls the speed of film movement by means of a constant speed motor and a variable transmission

worked by a servo system. A speed range of 1 : 40 is covered. The apparatus is built for very low altitudes, and the highest altitude covered is 1000' at 220 m.p.h. ground speed. An accuracy of film speed control within $\pm 10\%$ is claimed.

There is no fundamental objection to the application of this system for high altitude photography. Also the system of film speed control can be simplified by using a variable speed motor with electronic control and it is reasonable to expect that higher accuracy can be obtained.

4.6 Elimination of irregular movement

The image stability required in order to improve the resolution significantly is very high. It has been calculated in para.5 that in order to double the resolution of the present 36" lens used with Standard Pan film the angular velocity of the stabilised camera should not be greater than 0.00019 rad/sec. This is nearly thirty times greater than the stability obtainable with the gimbal mounting when flying on automatic controls.

The irregular movements of the camera are due to the vibration transmitted from the air frame, and the irregular movements of the aircraft in flight of aerodynamic pilotage, and atmospheric origin.

Both are oscillatory movements of a similar, rather irregular, character and differing mainly in frequencies. When combined they cover in effect the whole spectrum of frequencies ranging from the top frequency produced by the engine down to a few cycles per minute or less. As experiments carried out in the aircraft have shown, there exists no natural frequency which would not respond appreciably to these excitations.

A compromise is obtained by choosing a mounting of a natural frequency least affected by the usual frequency distribution of the air frame vibration and applying damping to prevent resonant vibration. In this way the best possible elimination of the higher frequencies due to engine excitation is obtained and the camera follows fairly closely the low frequency irregular movement of the aircraft.

Only rotational movements of the camera will affect the resolution. The velocities of translational vibration are always negligible as compared with the progressive velocity even in the case of compensation.

Therefore it is only necessary to eliminate the rotational vibration and to avoid transformation of translational vibration into rotational. This second condition is satisfied if as the result of translational displacement of the camera in any direction from its equilibrium position no moment of force about its C.G. is generated, i.e. the camera is supported at its C.G. In the case of a damped mounting this also means that the translational movement of the camera in the mounting must not generate moments about its C.G.

If this condition is fulfilled rigorously as it can be obtained with a gimbal suspension, the elimination of the translational vibrations is theoretically unnecessary and the gimbal can be rigid translationally. In practice this is not easily achieved and also the high accelerations characteristic of the high frequencies are undesirable in the camera. A compromise is obtained by a gimbal suspension with a certain amount of translational compliance. This is in fact a mounting with much higher translational than rotational natural frequencies. If the translational vibration is reduced to a sufficiently low value, less rigorous fulfilment of the condition of

support can be tolerated. A gimbal suspension based on this compromise with natural rotational frequencies near 100 c.p.m. and translational near 600 c.p.m. has been built (4).

In this mounting the angular velocity due to high frequency vibration has been reduced to, or below the level of irregular aircraft movement flown on automatic controls.

Still further reduction of high frequency vibration can be obtained by further reduction of the natural frequency and rigorous fulfilment of the condition of suspension at the C.G. which requires compensation for the mass movement due to film winding in the camera magazine. To obtain advantage of this further reduction of vibration the low frequency irregular movements due to aircraft instability have to be eliminated by stabilisation of the camera support in space. With a rather imperfect gyro stabilised mounting obtained by modification of the Minneapolis Honeywell mounting a reduction in the low frequency movements by a factor of 2-3 has been obtained. This performance could probably be considerably improved (21).

A better plan however is to reduce the natural frequency of the gimbal suspension to zero i.e. suspend the camera quite freely in neutral equilibrium without elastic restoring forces. Such suspension will be insensitive to all angular aircraft movements. In fact no rotational forces can be transmitted to the camera from outside. A self contained vertical seeking device must be provided on the camera, efficient enough to compensate for the accidental forces acting on the camera.

This plan has been adopted in an experimental suspension for an F.24 camera stabilised by means of a heavy gyroscope (Vickers Mk. II gyroscope) connected rigidly to the camera. The suspension is described in detail in Appendix V and the flying tests carried out with it in para. 5.22. It is considered that satisfactory stability can be obtained in this way. The contrivance is however cumbersome and not suitable for practicable application.

A new scheme to carry out this plan has been suggested by the Instrument Division R.A.E. in which electro-magnetic erecting torques controlled by gyroscopes mounted on the camera are applied to the gimbal axes. Application of the space cross principle is suggested.

In the devices constructed up to now care was taken to reduce the angular movement about two horizontal axes and less attention was given to the vertical axis. This is justified by the fact that the movement about the vertical axis will cause rotational movement of the image in the focal plane about the principal point as centre. It will thus be negligible in the middle of the image and will increase towards the edges. With the long focus lenses which are mainly coming into consideration for this type of photography, it will at the edge, scarcely be greater than 1/5 of the movement which would be produced by the same angular velocity about the horizontal axis.

With the high requirement for image stability however it will probably be necessary to account for the rotational movements about the vertical axis as well. This can be obtained by suspending the camera in a three axis gimbal. The movement about the vertical axis is necessary in any case for wind drift adjustment. By arranging for this axis to be gyro controlled by a direction seeking gyroscope with the azimuthal equilibrium position remotely controllable in relation to the fore and aft axis of the aircraft, both requirements could be satisfied. Alternatively the gyro stabilisation may be replaced by drift adjustment only if very high stability is not required.

In this case suspension at the C.G. must be rigorously satisfied and the mass shift due to film winding has to be compensated, in order to avoid transformation of translational vibration into rotational. It is thought however that small departures of the C.G. of the camera from the intersection of the gimbal axes in the vertical direction can be allowed and the compensation for the mass shift made unnecessary, if the film spools are arranged vertically provided that the whole gimbal is suspended as a free pendulum sufficiently damped, as shown in a schematic drawing on Fig.9.

In this way the accelerations acting on the camera at its point of suspension in horizontal directions will be limited in magnitude and rate of change by the low natural frequency of the pendulum suspension. It is expected that in case of a vertical c.g. shift of the camera the small and slowly varying moments of force caused by swinging of the pendulum suspension can be compensated by an efficient gyro controlled crusting system.

The translational vertical natural frequency of the suspended gimbal system should be low enough to eliminate the high frequencies of the support which would be harmful to the apparatus and could produce resonant vibrations of some of its parts. Also, resonance of the whole suspension must be avoided in order to keep the vertical accelerations low and allow greater error in the C.G. position in relation to the gimbal axes. It is considered that a natural frequency near 300 c.p.m. (between 200-600) with adequate damping would be convenient and produce no excessive gravity deflection.

The advantage of this scheme of suspension (pendulum with vertical compliance) is that it can be obtained by means of one compliant element only and the number of the necessary damping elements is also reduced. The compliant element can also play the part of the pendulum hinge.

5 Flying experiments

5.1 Experiences and applications in war time

During the late war reduction of the image movement in relation to the film was applied with success in certain cases. In all these cases the resolution was considerably affected by the movement and the stabilisation was limited to compensation for the progressive movement of the image.

In day photography movement compensation was applied to low altitude - large scale photography for reconnaissance of landing beaches. U.S.A.A.F. used the "Sonno" strip camera for that purpose. In the R.A.F. the orthodox camera with continuously moving film and periodically operated shutter was used. The movement was overcompensated and the effective image movement was reduced to half its value. This reduction in image movement has however produced a very significant improvement in resolution and no "blurr" could be observed (25).

In night photography movement compensation was applied at medium and low altitudes. At medium altitudes a relatively high degree of image stability was attempted in order to allow for a relatively long exposure time equal to the duration of the $\frac{1}{4}$ " Mk.II pyrotechnic flash i.e. of the order of $\frac{1}{15}$ - $\frac{1}{30}$ sec. This was successful at altitudes between 7-10000' and the results were better than those obtained with the American K-19b camera with photoelectrically operated shutter. At lower altitudes however, the shutter camera without compensation was giving better results.

Attempts were also made by reducing camera vibration and relying on good flying to stabilise the image sufficiently to allow high altitude photography using long focus lenses and more powerful flashes with longer duration. They were not successful because of insufficient flying stability. The contemplated use of automatic controls for increasing the stability was never tested adequately, but in view of the stability figures obtained (para.4.1) it is not expected that this would be successful. Stabilised camera mounting is required to achieve this aim.

At low altitudes utilising the $\frac{1}{2}$ " Verco flash cartridge of shorter flash duration partial image movement compensation was applied (over-compensation by 30%) with very good results similar as in day photography (26).

5.2 Experiments aiming at increased resolution

Two plans for utilising image immobilisation in order to increase the resolution of the lens-film combination in day photography were tested experimentally.

In the first plan advantage was taken of the fact that the image stability obtained with the gimbal mounting in the case of good flying is significantly greater than that required by the high speed film and $1/400$ sec. exposure. It is thus possible when compensating for the progressive velocity to increase the shutter time and to utilise the increased exposure for improving the resolution of the lens film combination.

The second plan included gyroscopic camera stabilisation about two horizontal axes.

5.21 Compensation for forward movement

In order to test the first scheme it was decided to replace the SIX film by an experimental fine grain film which was available at R.A.E., of a graininess similar to Panatomic X film and to reduce the lens aperture by one stop. It was decided to carry out the flying tests with the 20" Aviar and 36" Tulophoto lenses.

When calculating from the resolution measurements made by Toarle (19) (20) with these lenses, the expected gain in mean resolution when replacing the SIX film with Panatomic X and reducing the aperture by one stop an increase of 35% was predicted. A slightly smaller figure is obtained from Toarle's generalised formula (16). This would require an increase in exposure time of 6 times and the corresponding allowed image velocity would be 0.0050 rad/sec. with the 20" lens and 0.0030 with the 36" lens. This should be just obtainable for the 20" lens.

Test with 20" lens

Two F.52 cameras fitted with matched 20" F/5.6 Aviar lenses were flown in a Wellington aircraft at 10,000' and 240 mph. ground speed.

Camera A with a standard type 33 mounting, SIX film, lens at F/8, $1/400$ sec. shutter setting, and a minus blue filter.

Camera B was on a gimbal mounting with a moving film magazine loaded with fine grain film at F/11 with $1/70$ sec. shutter setting and a minus blue filter.

The movement during exposure in camera A is 0.00009 rad. which equals 0.45λ , for the lens at F/8. This corresponds to a reduction in resolution of 10% for test objects at right angles to the direction of movement. Thus we may expect that the effect of movement in Camera A is negligible and the difference in resolution between the two cameras is due to the difference in resolution of the lens-film combination.

It was intended to photograph the test object in order to compare the resolution quantitatively. Because of the formation of cloud in that area however only two photographs of the test object were obtained with $2\frac{1}{2}$ and $\frac{1}{2}$ groups more resolved on the fine grain negative than on the standard. This corresponds to an improvement in resolution of 58% and 12%.

A series of photographs of different objects in other parts of the country have been taken, allowing qualitative comparison. When comparing the resolution of the negatives obtained it has been found that out of the 71 pairs of negatives made, in 60 pairs, i.e. 84.5%, the fine grain compensated camera negative was noticeably better than the standard, in 5 pairs (7%) no difference in resolution could be found between the negatives and in 6 pairs (8.5%) the fine grain negative was noticeably worse than the standard.

Photographs in Figs. 10 and 11 which are 10 diam. enlargements from the original negatives show the representative improvement in resolution in different parts of the image field.

Tests with 36" lenses

Despite the smaller chance of obtaining improved resolution with the 36" lens, in view of the high requirements for image stability, tests have been carried out with these lenses because of their importance for reconnaissance photography.

Two flights have been made at an altitude of 15,000' and ground speed of 210 m.p.h.

In both cases camera A was on a standard Type 38 mounting with SXI film, F/8, 1/400 sec. shutter setting, minus blue filter.

Camera B on a gimbal mounting, moving film magazine with fine grain film F/11, 1/70 sec. shutter setting, minus blue filter.

The movement during exposure in the standard camera is 0.43λ at an aperture of F/8 and thus can be considered negligible.

Flight on 24.2.45

20 photographs of the R.A.E. test object were obtained. On the average an increase in resolution of 0.97 groups, i.e. 25% was obtained. On Fig. 17A the number of groups resolved is plotted against the angular separation from the camera axis. It indicates that the difference in resolution is greater in the centre than off axis. This difference is partly due to the lenses in both cameras being not perfectly matched. The lens in camera A was a standard lens and in camera B a lens with its spherical correction improved by figuring. The laboratory test (22) has shown that the figuring has improved the resolution noticeably on the axis, the average resolution has not been altered however, as off axis the resolution is slightly reduced. The interrupted line on Fig. 17A indicates the resolution of camera B after the difference in lens resolution as found in the laboratory test has been subtracted. It can be seen that after introducing this correction the resolution is with the

movement compensation higher all over the field by very nearly 1 group than in the comparison camera. This is slightly less than expected, when taking no account of the irregular movement.

On Fig. 18A the frequency distribution of the groups resolved is shown. The curve for the compensated camera is much flatter, which is due to the greater effect of irregular movement on the resolution but partly also due to the greater resolution differences over the field of the figured lens.

Photographs in Fig. 12 show the improvement in resolution obtained in the centre of the field, and fig. 13 at an angle of 4° where the difference in performance of the two lenses is not noticeable.

Flight on 13.4.45

In order to obtain more direct evidence of the gain due to improved lens/film resolution the test has been repeated in the same conditions as before with the exception that the magazines were exchanged on the cameras during the flight after several runs to eliminate the effect of differences in resolution of the lenses.

A third camera was also carried with fine grain film and movement compensation, exactly as camera B with the exception that it was mounted on a standard mounting instead of on a gymbal mounting in order to show the effect of vibration. The test was a failure however and on the 27 test photographs recorded on the average the resolution with stabilised cameras with fine grain film is 0.2 groups worse than in the standard camera. On several photographs the resolution on the compensated camera is from $2-2\frac{1}{2}$ groups higher than on the standard. On the majority of them however, the effect of movement in irregular directions is noticeable, which makes the average result lower than in the standard camera.

This scatter of results is shown on the 17B and 18R.

It is thought that this failure was due to unsatisfactory flying and in particular that the turn in was made too near the target and therefore the aircraft was not sufficiently steady over the target.

The flight was not repeated because the supply of fine grain film was exhausted.

Discussion of the results

In order to find the opinion of interpreters on the value of the improvement in resolution obtained in these tests a set of 9 pairs of prints obtained in the test with 20" lenses (5 pairs) and 36" lenses from flight on 24.2.45 (4 pairs) chosen at random have been submitted to third phase interpreters. The prints have been assessed by 8 interpreters and in 87% of the cases the print from the fine grain compensated negative was preferred.

These results confirm in broad lines the conclusions arrived at on a theoretical basis. An improvement in definition slightly smaller than predicted has been obtained. The results however depend very much on the steadiness of flying and it is not considered that the technique could be used with advantage in operational conditions in the way it has been tested.

It is concluded however on the basis of these results that if movement compensation is used a moderate improvement in resolution could be obtained at all altitudes by increasing the exposure time to

1/150 sec. and replacing the Standard Panchromatic film with a fine grain film of correspondingly lower speed - without changing the lens aperture at present in use. Supposing the shutter time in use at present to be 1/400 sec. an increase in resolution by approximately 15% could be obtained. This improvement is not significant but it should be kept in mind that it is comparable with the effect obtainable by trebling the film speed without changing its graininess or reducing the film graininess correspondingly without changing its speed. In actual effect it will be greater because the efficiency of the shutters improves with the increased shutter time. For example when trebling the blind width the effective exposure is trebled but the effective shutter - open time as it affects the movement will be increased by a factor smaller than 3.

It is thought that this improvement is one of the arguments justifying the recommendation of image movement compensation as a feature of the standard aerial camera.

The further, more important arguments in favour of this recommendation are:-

1. A great range of altitudes at which the effect of movement directly affects the resolution and therefore the gain is greater than that due only to improved lens/film performance. This range is increasing in proportion to the increase of aircraft velocity.
2. The introduction of movement compensation does not complicate the normal technique of air photography as the movement compensation mechanism will take care of the timing of camera cycles thus replacing the separate timing control.

As shown in para. 3.1 the accuracy of compensation necessary in most cases of high altitude photography even when the shutter time is increased will be small enough to make it easy in application. As a rule it will not be greater than the accuracy of timing required to obtain the correct overlap.

5.22 Gyro stabilisation and movement compensation

A gyro stabilised mounting for the F.24 camera described in Appendix V was constructed and ground tested by the author in the Kodak Research Laboratory at Harrow at the end of 1941. Early in 1942 it was brought to R.A.E. for air tests. There were several difficulties in carrying out the test. Later it was decided that no adequate development and production capacity was available at that time for the rather complicated project. Further tests on gyro stabilisation were postponed and the effort directed to the application of image movement compensation in night photography in unstabilised cameras.

Since the cessation of hostilities the work on this problem has been resumed and the experimental mounting air tested.

Microfilm film has been used in the air test with the 8" F/2.9 Pentax lens stopped to F/8 with minus blue filter and shutter time 0.09 sec.

A standard F.52 camera fitted with 20" F/5.6 Aviar lens stopped to F/11 with minus blue filter and 1/400 sec. shutter setting and standard panchromatic film was used as comparison.

The tests were carried out in a Wellington aircraft at 10,000'

altitude and 190 m.p.h. ground speed.

The angular resolution on the axis of the 8" Pentax at $f/8$ with Microfile film is according to Tearle (18). 13,400 lines/rad. (average for the three lenses investigated) and that of 20" Lyiar at $f/11$ with SX film is 9,000. Therefore considerably higher resolution should be expected with the stabilised camera. In a resolution test of the Pentax lens used in the experiment only an angular resolution of 9200 lines/rad. was obtained on the axis. No further investigation has been made into this discrepancy. It does not seem to be outside the probable margin of differences for different lenses of the same type as indicated by Tearle's results (18).

Only one successful flight has been made with the camera. Further tests had to be postponed because of unfavourable winter illumination and weather conditions. Of the resulting negatives 45% were unsharp because of movement, 28% show slight effect of movement and 27% are quite satisfactory.

Enlargements Fig. 14 and 15 show the results obtained on the sharp negatives. The Microfile negatives are enlarged 20 diameters and the negatives on SX film 8 diam. so that they are brought to the same scale. Fig. 16* shows a negative obtained with 8" lens and SX film taken in similar conditions with $1/400$ sec. at $f/11$ and enlarged 20 diam. When compared with 14A and 15A it shows the difference due to the use of fine grain film and stabilisation. The comparison of prints Fig. 14 and 15 A and B obtained with lenses of different focal length reveals practically the same ground resolution. The Microfile print appears slightly less sharp at first sight but this is usual when comparing two prints of the same resolution and different graininess. The actual resolution of high contrast detail is the same on both prints. In the low contrast detail the fine grain print shows a noticeable advantage, e.g. in the pattern of the framework on the roof of the shed on Fig. 15 or the pattern of the tree-crowns and detail on the ground on Fig. 14 marked by circles. This is in agreement with the effect of graininess on resolution of low contrast detail observed in an earlier work (27).

The small proportion of sharp negatives obtained in this test is probably due to the movement compensation arrangement not being very satisfactory and it is expected that with more experience in handling the camera in the air a better result could be achieved. It is thought, however, that the results obtained justify further work along these lines and the development of a stabilised mounting capable of carrying a camera fitted with a long focus lens.

5.3 Utilisation of the High Resolution Negative

The results of this test are bringing into light another problem connected with increasing resolution by means of image stabilisation, the problem of utilisation of the high definition negative.

The enlargements Fig. 14 and 15 were made by means of a 2" $f/3.5$ Elmar lens stopped to $f/12$. No significant loss of detail is noticeable when comparing the enlargements with the original negative. This is obtained, however, only by very careful work and it is expected that the difficulties would be much greater if enlargements of greater areas are taken into account requiring longer focal length lenses for enlarging. Also enlarging of all negatives would require very large quantities of photographic paper and skilful work and the efficiency of the process is small. It is thus essential that the photographs should be interpreted from contact prints as usual at present.

* Together with Figs. 25 & 26.

It has been found, however, that the resolving power of the standard Service bromide papers on the usual base is not adequate to reproduce the image of these very sharp negatives and a very significant loss of detail is noticeable on the contact prints. Still worse results are obtained on the waterproof base.

Satisfactory prints could be obtained on Kodak Maximum Resolution plates. It is probably not necessary to use such an extreme resolution emulsion to obtain adequate reproduction of the negative detail and the development of satisfactory positive material should not present very great difficulties.

A further problem however, arises in viewing the prints. A magnification of 15 - 20X is necessary to allow convenient observation of image detail. This requires a completely novel design of interpreting and stereo viewing equipment.

6 Conclusions

6.1 The image movement which can be tolerated during exposure without affecting significantly the resolution is approximately 0.6 of the test magnitude resolved by the lens film combination in the stationary image.

6.2 It is estimated that the effect of camera vibration and aircraft instability on the resolution of aerial photographs is negligible in the present technique of day photography. This is in agreement with practical experience. It is expected, however, that a further increase in angular resolution of 30% or more obtained, e.g. by increasing the focal length of the lens would make the adverse effect of these movements noticeable. This would make necessary a reduction in irregular aircraft movement and vibration or, alternatively, a reduction in shutter time. In night photography with pyrotechnic flashes the effect of these movements is significant in many cases.

6.3 The effect of forward movement of the aircraft is significant in a great range of altitudes and overrides that of the irregular movement and vibration. It is estimated that in day photography with the new type of 36" lens and 500 m.p.h. ground speed the effect of movement with 1/400 sec. exposure will be still noticeable at an altitude of 43000' and above at 22000'. This applies to the perfect stabilized mounting. With the presence of vibration and irregular movement these altitudes will be still greater because of the additive effect of movements. In all applications of night photography with pyrotechnic flashes the adverse effect of image movement on resolution is significant.

6.4 It is thus concluded that in day photography the effect of movement can be eliminated completely by image movement compensation without the need to modify the mountings and the shutter time of 1/400 sec. at present in use. The same still applies to 1/300 sec. exposure time.

6.5 It is estimated that in night photography with 12" F/2.5 or shorter focal length lenses and shutter times of 1/50 sec. or shorter the effect of movement can be eliminated completely and the resolution of the lens film combination obtained by means of image movement compensation. For longer exposure times and lens film combinations of higher resolution, reduction of the irregular movement and vibration in addition to the compensation becomes necessary.

The reduction of irregular movement and vibration by means of a stabilized mounting and movement compensation is the condition for obtaining satisfactory ground resolution in high altitude night

photography with long focus lenses employing the "open plate" technique and utilizing the full light output of powerful pyrotechnic flashes of relatively long duration.

6.6 When the immobility of the optical image in relation to the film is increased, the resolution of the photographs can be improved by introducing fine grain film. By compensating for the forward velocity and improving the camera mounting, an improvement of approximately 25% can be obtained in this way. The results, however, depend largely upon the steadiness of flying. By means of full stabilisation of the optical image, i.e. by means of an efficient stabilised anti-vibration camera mounting in conjunction with compensation for forward movement, doubling of the resolution is practicable. This is a gain of the same order as has been obtained during this war by increasing the focal length of the lenses. It corresponds to an increase of the focal length by a factor of four.

6.7 If the irregular movements are negligible, the accuracy in compensation for forward velocity required in order to obtain the full resolution of the lens-film combination, may be expressed as a percentage of the velocity. It is equal to 100×0.6 of the magnitude of ground detail resolved by the stationary lens, divided by the distance travelled by the aircraft during the exposure time. It is thus in the first approximation inversely proportional to the image scale, aircraft speed and shutter time.

6.8 The accuracy of methods of image movement compensation by moving the film or lens, or by rotating a glass plate arranged between the lens and film, or by rocking the camera is adequate for most purposes when using narrow angle lenses. For wide angle lenses the errors become excessive and only the methods of moving the film or the lens are satisfactory.

6.9 The accuracy in estimation of the velocity of image movement compensation from the information given by the navigational instruments is adequate for most purposes. At low altitudes the use of a radio altimeter is preferable. Higher accuracy required if gyro stabilised mountings are used can be obtained with the sighting method and also may be expected from the scanning method.

6.10 The resolution obtainable in the stabilised aerial camera on fine grain film is higher than the resolution of printing papers at present in use. Also the magnification of the optical appliances used for viewing and interpretation of aerial photographs is not adequate to resolve all the detail of such negatives.

7 Recommendations

7.1 The introduction of a camera with image movement compensation and automatic overlap control as a standard camera for reconnaissance photography for use with the standard panchromatic film and short shutter times, is recommended. The moving film camera is suggested. The use of the camera in the stabilised mounting with long duration exposures should be allowed for in the design.

7.2 The development of a stabilised anti-vibration camera mounting for day and night photography with long exposure times is recommended. The mounting should be capable of carrying a camera fitted with 36" telephoto lens. The principle of gimbal mounting without elastic or gravitational coupling forces, with gyro controlled camera altitude, is suggested in conjunction with a pendulum type anti vibration mounting.

R.A.E. Report No. Ph. 1.

7.3 Research and development on a photoelectric scanning device for low, medium and high altitudes for automatic control of movement compensation is recommended.

7.4 Further research on the effect of image movement on resolution is recommended. Extension of measurements to a greater number of lenses and films of different graininess is suggested.

7.5 The development of negative and positive fine grain materials for use with the stabilised camera in day photography is recommended.

7.6 The development of a magnifier and stereoscope for viewing the high resolution photographs is recommended.

8 Acknowledgments

I wish to thank Mr. C.J. Duncan for discussions and encouragement during the progress of the work and to Mr. K.E. Williams for working out the argument found in Appendix III.

REFERENCES

<u>No.</u>	<u>Author</u>	<u>Title, etc.</u>
1	W. Romer	Compensation for image movement in night photography. A.P.R.C. Note No. 171. R.A.E. Ph. No. 216. January, 1943.
2	W. Romer	Image movement compensation - Aircraft stability measurements. A.P.R.C. Note No. 172. R.A.E. Ph. No. 236. July, 1943.
3	W. Romer	Service trial of night cameras: F.52 open plate with Type 44/52 moving film magazine versus K19B. A.P.R.C. Note No. 226. R.A.E. Ph. No. 312. December, 1944.
4	W. Romer	Progress report on investigation on camera mountings. A.P.R.C. Note No. 178. R.A.E. Ph. No. 270. April, 1944.
5	E.W.H. Selwyn	Theoretical estimation of combined effects of film and lens on resolution. A.P.R.C. Note No. 3, H.698. April, 1940.
6	J.M. Gregory	Interim report on the effect of image movement on definition of air photographs. A.P.R.C. Note No. 154, H.1178. October, 1943.
7	J.M. Gregory	Optimum exposure time and aperture for air photography with 20" Aviar lens and SXX film. A.P.R.C. Note No. 192, H.1227. June, 1944.
8	J.M. Gregory	The optimum lens film exposure time combination for use in air photography. A.P.R.C. Note No. 212, H.1258. February, 1945.
9	W.M. Wreathall & D.J. Walters	Test on two Ross 20" F/6.3 Survey lenses. R.A.E. Tech. Note No. Ph. 300. July, 1944.
10	D.J. Walters	Comparison tests on three 20" F/5.6 T.T.H. Aviar lenses. R.A.E. Tech. Note No. Ph. 305. November, 1944.
11	W.M. Wreathall	Tests on a prototype lens Ross 20" F/6.3 Xpress R.A.E. Tech. Note No. Ph. 296. July, 1944.
12	W.M. Wreathall & B. Denton	Comparison of British, Canadian and Australian 36" F/6.3 Telephoto lenses. R.A.E. Tech. Note No. Ph. 318. February, 1945.
13	W.M. Wreathall	Tests on a prototype Wray 36" F/6.3 telephoto lens. R.A.E. Tech. Note No. Ph. 328. June, 1945.
14	W. Romer	Design and testing of moving film magazine for night photography. R.A.E. Ph. 269. A.P.R.C. Note No. 183. April, 1944.

R.A.E. Report No. Ph. 1.

No.	Author	Title, etc.
15	J.L. Tearle	Resolution tests on a 7" T/2.5 Ektar lens and a 12" F/2.5 Ektar lens. A.P.R.C. Note No. 195, H.1295. May, 1944.
16	J.L. Tearle	Survey of lenses used in air photography Part VI. Analysis of experimental data. A.P.R.C. Note No. 147, H.1146. July, 1943.
17	Davies, Selwyn, Tearle and Gregory	Present position of work for the Air Photography Research Committee on lens and film characteristics. A.P.R.C. Note No. 141, H.1104. April, 1943.
18	J.L. Tearle	Survey of lenses (Pt. II) three 8" Pentax lenses. A.P.R.C. Note No. 42, H.882. January, 1942.
19	J.L. Tearle	Resolution tests on two 20" Aviar F/5.6 lenses. A.P.R.C. Note No. 44, H.906. February, 1942.
20	J.L. Tearle	Survey of lenses Pt. IV. 30" Ross Astro Aero and 36" Booth 36" telephoto. A.P.R.C. Note No. 98, H.1012. October, 1942.
21	K.R. Williams	Ground tests of a gyro stabilised camera mounting. R.A.E. Tech. Note No. Ph. 338. January, 1946.
22	C.A. Padgham, J.M. Kelly & D.J. Walters	Comparison of figured and unfigured T.T. & H. Booth Telephoto 36" lenses. R.A.E. Tech. Note No. 260. December, 1943.
23	A.S. Fitzgerald	The Petoscope: A new principle in photoelectric applications 1936. Journ. Frankl. Inst. Vol. 222, pp. 289-236.
24	Chicago Aerial Survey Corp.	Automatic Film Speed synchroniser for Sonne Strip Aircraft Camera. Preliminary handbook. April, 1945.
25	Staff of Photographic Division	Large scale vertical air photography employing the moving film principle. A.P.R.C. Note No. 198, R.A.E. Ph. 291. June, 1944.
26	C.J. Duncan & R.R. Voller	Progress report - Low altitude night photography. Cartridge 1/2" flash (Veray). A.P.R.C. Note No. 210, R.A.E. Ph. 277. April, 1944.
27	W. Römer	Resolution of test objects of low contrast. A.P.R.C. Note No. 102, H.1006. November, 1942.

Circulation:-

D.Inst./E.D.	
A.D.H.D.Inst.	
D.D.Photos	
R.D.Inst.(RH.) A.	(Action copy) (3)
R.T.P./T.I.B.	(70 + 1)
C.S.A.	-
D.G.S.A./A.	
D.D.G.S.R.	
E.D.T.D.	
D.T.R.D.	
K.A.E.E.	(2)
A. & A.T.R. Boscombe Down	
C.S.(E), R.A.E.	
Library	
Head of Dept. (Mr. Richards)	
Head of Air Photo Div. (Mr. Brock)	
Specifications	
Heads of Sections	

Appendix IMeasurement of irregular aircraft movement.

A short account of the method of measuring the aircraft stability by recording the light tracks in a camera carried in the aircraft, is given as well as the obtained results. More details are found in (2).

The tracks were obtained in Wellington and Mosquito aircraft flown at night in smooth weather over a flashing light. The light flashing at a frequency of 35 c.p.s. was obtained by rotating a scooter disc above a steady light. The camera was flown over the flashing light with the shutter open and the film was wound over after each run. The measurements include 29 runs over the target made in 6 flights by four different pilots. 2 runs were made with a Mk. IV Automatic Pilot. The total duration of the analysed flight is 7 minutes.

The co-ordinates of every tenth spot were measured with a travelling microscope with the x-axis parallel to the fore and aft aircraft axis.

The mean \bar{x} and \bar{y} displacement corresponding to the forward aircraft movement and to the drift velocity respectively, was subtracted from the individual displacements and in this way the δx and δy due to irregular movements were obtained.

These displacements are due to the camera vibration and irregular movements of the aircraft. The camera vibrations are of relatively high frequency as compared with the aircraft movements. In order to eliminate their effect the displacement values are plotted against time and the smoothed curves of the slow motion drawn. From these curves are read the δx and δy displacements due to aircraft movements only.

The fore-aft and athwartship components were then added geometrically and the magnitude of the vector of the resulting movement calculated.

$$\delta = \sqrt{(\delta x)^2 + (\delta y)^2}$$

This displacement represents the sum effect of the roll, pitch and yaw movement of the aircraft. Supposing there was no yaw the angular velocity of rotation about a horizontal axis resulting from the pitch and roll movement would be for small image angles $\frac{\delta}{tF}$ where t is the period of flashing and F the focal length of the lens. If there was no pitch and roll, the angular velocity of yaw would be $\frac{\delta}{t\ell}$ where ℓ is the distance of the recorded spot from the principal point of the photograph. The mean value of ℓ in the described experiment was 1.9", the F value was 10", 14" and in few cases 20". Thus at least 5 times as great yaw velocity as compared with roll or pitch is necessary to produce the same δ value. From the aircraft stability measurements made by means of the gyroscopic recorder it is known that the roll, pitch and yaw movements are of similar order. This means that the yaw movement is only responsible for the movements recorded in the camera to a relatively small extent. It was therefore thought justifiable to express the measured irregular aircraft movements as pitch and roll movement only and in order to simplify the notation to calculate the angular velocity from the formula

$$\theta_1' = \frac{\delta}{tF} \text{ radian/sec.}$$

In order to calculate the mean velocity from these varying movements we must first know the function in which the mean values have to be applied. In this case this is the photographic resolution as a function of the image movement. The discussion of experimental results para. 3.2 leads to the conclusion that this function has a concave shape and is reasonably well approximated by a quadratic function. The R.M.S. velocity values should thus be used. As in previous reports the mean velocities were quoted, the mean and R.M.S. velocities were calculated and are shown in Table I. The maximum velocity found in the last column has been obtained by calculating the mean of the 10% highest velocities recorded during the run.

Table IV

Angular velocities of image movement in aerial camera due to irregular aircraft movement

$$\theta_1' = \frac{\delta}{tF} \text{ rad./sec.} \quad \delta = \sqrt{(\delta x)^2 + (\delta y)^2}$$

Exp. No.	Aircraft	Altitude feet	Run dur. measured sec.	F inch	θ_1 Mean rad/sec	θ_1 R.M.S. rad/sec	θ_1 Max. rad/sec	
1	Wellington	10,000'	9.0	14"	0.0020	0.0023	0.0042	Auto- matics
2	"	"	10.0	"	0.0027	0.0032	0.0050	
3	"	"	12.0	"	0.0094	0.0109	0.0170	Manual
4	"	"	14.0	"	0.0014	0.0016	0.0030	
5	"	11,000'	15.2	"	0.0015	0.0018	0.0035	"
6	"	10,100'	14.3	"	0.0029	0.0032	0.0045	"
7	"	10,000'	14.3	"	0.0039	0.0046	0.0173	"
8	"	10,100'	17.7	"	0.0042	0.0049	0.0070	"
9	"	10,200'	15.0	"	0.0090	0.0105	0.0210	"
10	"	10,000'	17.0	"	0.0170	0.0203	0.0320	"
11	"	10,100'	14.0	"	0.0074	0.0087	0.0160	"
12	"	10,000'	15.0	"	0.0090	0.0103	0.0165	"
13	"	10,000'	14.0	"	0.0056	0.0065	0.0120	"
14	"	10,100'	13.0	"	0.0075	0.0081	0.0115	"
15	"	9,800'	18.0	"	0.0082	0.0088	0.0170	"
16	"	10,000'	16.0	"	0.0067	0.0078	0.009	"
17	"	10,000'	13.0	"	0.0048	0.0056	0.011	"
18	"	9,900'	13.0	"	0.0074	0.0087	0.014	"
19	"	10,000'	11.0	"	0.0102	0.0119	0.0175	"
20	"	10,000'	12.0	"	0.0044	0.0051	0.0090	"
21	Mosquito	10,100'	7.2	20"	0.0035	0.0040	0.0075	"
22	"	14,100'	10.0	"	0.0042	0.0052	0.0100	"
23	"	10,000'	17.0	10"	0.0040	0.0047	0.0125	"
24	"	10,400'	12.0	"	0.0071	0.0083	0.0170	"
25	"	10,200'	18.0	"	0.0040	0.0047	0.0100	"
26	"	10,100'	14.0	"	0.0034	0.0040	0.0070	"
27	"	12,200'	18.0	"	0.0042	0.0049	0.0120	"
28	"	14,100'	17.0	"	0.0049	0.0057	0.0100	"
29	"	13,000'	22.0	"	0.0035	0.0045	0.0155	"
		Total	412.7					
Mean					0.0058	0.0083		

These results are in good agreement with those obtained previously using the same method (2). The mean angular velocity obtained in the runs 1 and 2 made with automatic pilot (16. IV) is 0.0023 rad./sec. and the R.M.S. is 0.0028 rad./sec.

Runs 3-20 with manual control were made by three different pilots and can be considered as examples of average straight and level flying in good weather conditions. The mean angular velocity obtained in these runs is 0.0062 rad./sec. and the corresponding R.M.S. velocity is 0.0092 rad./sec. The corresponding maximum velocities for individual runs oscillate between values of 0.0020 - 0.032 rad./sec.

The runs 21-29 were made in Mosquito aircraft by one pilot, who was trying to fly the aircraft as steadily as possible. The pilot was not experienced in this type of flying and this was his second attempt, the first being a failure. The resulting mean angular velocity is 0.0043 rad./sec. and the R.M.S. velocity is 0.0052 rad./sec. The obtained steadiness is fairly consistent in all those runs and the maximum velocities vary between 0.0070 - 0.0155 rad./sec.

The mean angular velocity obtained for all the runs is 0.0058 and the R.M.S. velocity is 0.0083 rad./sec.

A few figures on the steadiness in actual photographic reconnaissance flights in Mosquito aircraft over enemy territory at night were obtained from the analysis of photographs reported in (3) page 9. The angular velocities calculated from the figures given in that note are shown in Table V. There was some evidence that the very high value of movement in Exp. No.4 is due to the aircraft assuming a horizontal position after a banked turn at the beginning of the series of exposures.

Table V

Angular velocity of image movement in an aerial camera due to irregular aircraft movement in service conditions. Mosquito aircraft - night photography.

Exp. No.	Altitude	θ_1 rad./sec.
1	10,000	0.0064
2	"	0.0002
3	7,000	0.0130
4	"	0.0650
5	"	0.0097
6	"	0.0069
7	"	0.0160

Omitting this figure the mean angular velocity for the remaining 6 observations is 0.0088 rad./sec. and the corresponding R.M.S. value is 0.0109 rad./sec. The figures given in Table IV represent the effect of pitch roll and yaw of the aircraft, the figures in Table V include drift and errors in estimation of altitude and ground speed as well as errors of the camera mechanism. These figures are obtained from measurements made over relatively long time intervals of the order of 10 seconds. Therefore the figures obtained are rather low and should be considered only as a very rough confirmation of the results contained in Table IV.

Appendix IIRotating Glass Plate - Error in Compensation.

Consider a pencil of light in a plane perpendicular to the axis of rotation of the glass plates of thickness p and refraction index μ . From the diagram fig. 17 it follows:

$$\frac{\sin \alpha + \beta}{\sin \gamma} = \mu$$

$$S = \frac{p}{\cos \gamma} \sin [(\alpha + \beta) - \gamma] \frac{1}{\cos \alpha}$$

$$\frac{S \cos \alpha}{p} = \sin (\alpha + \beta) - \frac{\frac{1}{2} \sin 2 (\alpha + \beta)}{\mu^2 - \sin^2 (\alpha + \beta)}$$

considering $\alpha = \text{constant}$ and differentiating with respect to $(\alpha + \beta)$ we find

$$\frac{dS}{d(\alpha + \beta)} = \left\{ \cos (\alpha + \beta) - \left(\frac{\mu^2 \cos 2 (\alpha + \beta) + \sin^4 (\alpha + \beta)}{\mu^2 - \sin^2 (\alpha + \beta)} \right)^{1/2} \right\} \frac{p}{\cos \alpha}$$

β must always be near zero because a glass plate inclined at a considerable angle to the lens axis introduces astigmatic aberration.

On the axis $\alpha = 0, \beta = 0$

$$\frac{dS}{d(\alpha + \beta)} = p \left(1 - \frac{1}{\mu} \right)$$

Supposing the angular velocity of the plate adjusted so as to obtain the correct compensation on the axis we find for any value of α the error in compensation expressed in % of the uncompensated velocity.

$$E\% = \frac{1}{\mu - 1} - \frac{\mu (\mu^2 \cos 2\alpha + \sin^4 \alpha)}{(\mu - 1) \cos \alpha (\mu^2 - \sin^2 \alpha)^{3/2}} \cdot 100 \quad (10)$$

In Fig. 7 the errors are plotted as functions of α (the angular separation from the optical axis) for $\mu = 1.52$ (full line).

Appendix III

Rocking Camera - Error in Compensation.

Suppose L to be the lens of a camera carried in the aircraft and P a point on the ground and p its image in the camera, shown in the diagram on fig. 20 in three projections. Q and q represent the traces of the camera axis in the ground plane and image plane respectively.

The camera is rotating about a horizontal axis $A-A$ passing through the lens perpendicularly to the flight direction in such a way that Q does not move with respect to the ground. The third projection marked "3" is in a plane parallel to the axis of rotation and the line $P-p$. We consider Q on the ground and its image in the camera as origins of two co-ordinate systems in the ground plane and the image plane. The traces of a plane passing through Q and q parallel to the line of flight in the ground plane and the image plane respectively are the X axes of the two co-ordinate systems.

In the triangle $O''L''P''$

$$\frac{X}{\sin \Omega} = \frac{H \sec \alpha}{\cos (\alpha + \Omega)}$$

If $\sec \alpha \sin \Omega = X (\cos \alpha \cos \Omega - \sin \alpha \sin \Omega)$ dividing throughout by $\cos \Omega$ and rearranging

$$\tan \Omega = \frac{X \cos \alpha}{H \sec \alpha + X \sin \alpha}$$

$$\text{now } x = f \tan \Omega = \frac{F X \cos \alpha}{H \sec \alpha + X \sin \alpha}$$

$$\frac{dx}{d\alpha} = -F X \frac{\sin \alpha (H \sec \alpha + X \sin \alpha) + \cos \alpha (H \frac{\sin \alpha}{\cos^2} \alpha + X \cos \alpha)}{(H \sec \alpha + X \sin \alpha)^2}$$

Supposing $\alpha = 0$

$$\frac{dx}{d\alpha} = -F \frac{X^2}{H^2}$$

and

$$\frac{d\alpha}{dt} = -\frac{V_A}{H}$$

where V_A is the ground speed of the aircraft

$$\frac{dx}{dt} = \dot{x} + \frac{FV_A}{H} \frac{X^2}{H^2}$$

From the diagram we find

$$y = y''' = F \sec \Omega \cdot \tan Y$$

$$\tan Y = Y''' / P''L'' = \frac{X}{H^2 + (X + H \tan \alpha)^2}$$

The variation in length of L' P' during exposure may be neglected since it will only involve a second order correction and

$$y = \frac{f Y}{\sqrt{H^2 + (X + H \tan \alpha)^2}} \sec \Omega$$

$$\frac{\partial y}{\partial \alpha} = \frac{(H \tan \alpha + X) \sec^2 \alpha H}{H^2 + (X + H \tan \alpha)^2} \sec \Omega$$

when $\alpha \rightarrow 0$

$$\sec \Omega = \frac{\sqrt{X^2 + H^2}}{H}$$

$$\frac{\partial y}{\partial \alpha} = \frac{F Y V_A}{H} \cdot \frac{X}{H^2 + X^2}$$

$$\frac{\partial y}{\partial t} = y \frac{F Y X V_A}{H (H^2 + X^2)}$$

$$(\dot{s})^2 = (\dot{x})^2 + (\dot{y})^2$$

where (\dot{s}) is the scalar velocity of the image p

$$(\dot{s}) = F V_A / H \sqrt{\frac{X^4}{H^4} + \frac{X^2 Y^2}{(X^2 + H^2)^2}}$$

Thus the error in compensation expressed as a percentage of uncompensated angular velocity is

$$E\% = 100 \left[\frac{X^4}{H^4} + \frac{X^2 Y^2}{(X^2 + H^2)^2} \right] \quad (11)$$

Appendix IVImage movement in a tilted camera.

In order to calculate the mean velocity of image movement and to show the magnitude of errors involved two special cases are discussed. Diagram Fig.21.

Consider the camera C in the aircraft tilted at an angle α to the vertical about the transverse axis (fore and aft tilt) and a point A or A' on the ground lying in the vertical plane passing through the lens parallel to the line of flight. Assume the sighting angle of A or A' from the aircraft to be $\alpha + \beta$ or $\alpha - \beta$ to the vertical. The image angle to the camera axis is then $+\beta$ or $-\beta$

From geometrical consideration we find the velocity of movement of the image of A or A' in the focal plane of the camera for fore and aft tilt

$$\begin{aligned} V_f &= \frac{V_A \cdot F}{H} \cdot \frac{\cos^2 (\alpha \pm \beta)}{\cos^2 \beta} \\ &= V_v \cdot \frac{\cos^2 (\alpha \pm \beta)}{\cos^2 \beta} \end{aligned} \quad (12)$$

where V_v is the velocity in the vertical camera.

The image movement of points not lying in the plane passing through the lens parallel to the line of flight will not be parallel to the intersection of the said plane with the focal plane. The above formula expresses the component of the movement parallel to this intersection. The angle β is then measured in projection on that plane.

In a similar way we find for a camera tilted about the axis parallel to the line of flight (sideways tilt) the velocity of image movement is

$$V_s = V_v \frac{\cos (\alpha \pm \beta)}{\cos \beta} \quad (13)$$

This formula is valid for all points of the image supposing β measured in projection on a plane perpendicular to the axis of tilt.

The image velocity in the focal plane varies with the angular separation from the axis as a non-linear function which is not symmetrical with respect to the principal point of the photograph.

The velocity of compensation which will produce equal errors in compensation for $+\beta$ and $-\beta$ for a given $|\beta|$ (e.g. on image edges) is for fore and aft tilt.

$$V_f (\text{mean}) = V_v \frac{1}{2} \left(\frac{\cos^2 (\alpha + \beta)}{\cos^2 \beta} + \frac{\cos^2 (\alpha - \beta)}{\cos^2 \beta} \right) \quad (14)$$

and for sideways tilt

$$V_s (\text{mean}) = V_v \frac{1}{2} \left(\frac{\cos (\alpha + \beta)}{\cos \beta} + \frac{\cos (\alpha - \beta)}{\cos \beta} \right) \quad (15)$$

R.A.E. Report No. Ph. 1.

These correction factors for tilt by which the image velocity calculated for the vertical camera has to be multiplied are very near $\cos^2 \alpha$ and $\cos \alpha$. On Fig.22 the correction factors for fore aft tilt calculated from (15) are plotted against tilt angles for an F.52 camera fitted with 36" $\beta = 5^\circ 30'$ lens and an F.24 camera with 8" lens $\beta = 17^\circ 30'$ supposing equal errors at the edges. On the same graph the differences between image velocity at the edge and mean compensation velocity expressed as fraction of V_f mean, i.e. the errors in compensation are plotted. The sideways component of the movement has not been taken into account and the figures apply to the middle points of edges of the camera field.

Fig.23 shows in similar way the correction factors and maximum errors for sideways tilt.

Appendix V

Construction and Ground Tests of a Gyro
Stabilised Camera Mounting.

The design and construction of this experimental mounting was undertaken early in 1941 in order to obtain experience on stabilisation of the optical image in the aerial camera and confirm experimentally the expected gain in resolution.

The plan adopted was the rigorous fulfilment of the principle of suspension at the C.G. with the smallest possible friction without elastic or gravitational restoring force and stabilising the direction of the camera axis in space by rigid connection with a gyroscope spinning about a vertical axis.

The compensation for forward movement was obtained by rocking the camera.

The experimental suspension was designed for the F.24 camera and is shown on figs. 24 and 25. The author was at that time with Messrs. Kodak at Harrow. An F.24 camera with 8" Pentac f/2.9 was lent by R.A.E. and a Vickers Mk.II gyroscope was obtained on loan from the Admiralty. The camera and the gyroscope are mounted on an H shaped steel tubing frame (1) suspended by means of a small ball race gimbal (4). The whole is carefully balanced by means of three weights (5) (6) and the third weight moving inside the tube by means of the screw (7). The weight (5) is calculated in such a way that shifting it for one turn compensates the C.G. shift due to rewinding of one frame of film.

The gyroscope has a radius of gyration of 2.21" and $5\frac{1}{2}$ lb. mass. It is A.C. driven and spinning at a rate of 19,000 r.p.m. It has been mounted in an evacuated sphere in order to reduce the drag. This has allowed the gyroscope to be driven by a Brown Compass rotary converter driven by 50V D.C. supplied from accumulator battery. No vertical rocking device was provided and the camera was maintained in the desired attitude by applying manually the necessary torque.

This size of gyroscope was found adequate to obtain satisfactory stability of the suspended camera even in case of small inaccuracies in C.G. balance. It was found at first, however, that due to the great inertia of the camera connected rigidly with the gyroscope there was a tendency for circular vibrations to occur in which the vertical axis of the system was describing a cone with the apex at the C.G. The vibrations are very easily excited, e.g. by the rocking movement of the camera, and take several seconds to die out. This was eliminated by mounting the gyroscope freely about one of its horizontal axes, with application of viscous damping. This was obtained by means of the two soft rubber bushings (8) and the syphon bellows (9). The suspension on rubber bushings insulates the camera from gyroscope vibration.

The camera is arranged to rock on the pivots (10) about the horizontal axis passing through its C.G., so that this movement does not upset the balance of the whole mounting. The position of the camera is adjustable with relation to the rocking axis to allow the fulfilment of this condition for lenses of different focal length. The rocking movement is obtained by means of a cam mechanism driven by a small D.C. motor controlled by a potentiometer. The motor and worm gear is covered by (11). The cam (12) is shaped so as to provide the correct compensation movement ($d \tan \alpha / d t = \text{constant}$) for

$\frac{2}{3}$ of the cam rotation. The return movement is with constant acceleration the sign changing on half way.

The whole frame is rotatable on the short shaft (13) in relation to the gimbal about the vertical axis in order to take account of the wind drift of the aircraft, and can be clamped by means of the nut (14).

A low power sighting telescope (3X) with a graticule and a deflecting mirror allowing convenient head attitude is fixed parallel to the camera axis (15). The exit pupil of the telescope is arranged $\frac{1}{2}$ " outside the eyepiece lens in order to avoid touching the camera when using the sight.

The compensation device is operated by adjusting the motor speed and the drift angle until immobility of image in the sight during the compensation stroke is obtained.

The camera shutter is modified by enlarging the slit width and slowing down the movement of the blind by means of an air vane mechanism.

In the first version of the mounting the supporting bars (15) were much longer and rested on soft sponge rubber cushions in order to reduce the effect of airframe vibration. When testing the suspension on a vibrating frame noticeable rotational vibration of the camera could be detected. This was not expected in view of the suspension in the C.G. of the system and is probably due to insufficient rigidity of the whole structure. This causes elastic deformations in the structure due to translational accelerations resulting in rotational movements of components. Also some resonance in frequencies about 2800 c.p.m. was noticed.

To obviate this the line of more perfect insulation from airframe vibration was adopted. The sponge rubber cushions were replaced by rubber cords (17) with hydraulic dampers (18). Satisfactory results were obtained.

Ground tests of resolution were carried out with the aim of checking the effect of vibration caused by the gyroscope and the shutter action on the resolution as well as efficiency of co-ordination of compensation movement of the camera with the ground movement. The camera was suspended in the mounting 15' above the test object. Microfilm fine grain film was used with Cobb test objects of 0.7 and 1.6 density difference.

No effect of vibration caused by the gyroscope on the resolution could be noticed.

The effect of vibration caused by shutter action was tested by making the exposure by means of a lens cap without touching the lens and by means of the shutter. With the shutter set for 0.05 sec. and electrically released the resolution was consistently reduced by 10 - 25%. The shutter seemed to work extremely smoothly but the action of the releasing solenoid causes a shock which is recorded on fig. 26. This record has been obtained by photographing a stationary point light source with the rocking camera with shutter blind removed.

When the shutter has been adjusted for an exposure time of 0.09 sec. by modifying the gearing the effect disappeared completely. No further investigation into this effect has been made and the slower shutter setting was used for further tests.

R.A.E. Report No. Ph.1.

When the movement compensation was tested with a moving test object and rocking camera, it was found somewhat difficult to obtain perfect immobility of the image in the camera sight. This is probably due to unsatisfactory accuracy of the cam. No reduction of resolution was noticed due to this cause for slow test object movements corresponding to flying at high altitudes. For the angular velocity of test object movement of 0.035 rad./sec. corresponding to 9000' altitude and 225 m.p.h. ground speed, slight deterioration of resolution could be noticed. When doubling the speed of test object movement a reduction in resolution of 10 - 15% was observed.

It was considered that these results justified an air test of the suspension.

REPORT PH. I
FIG. I.

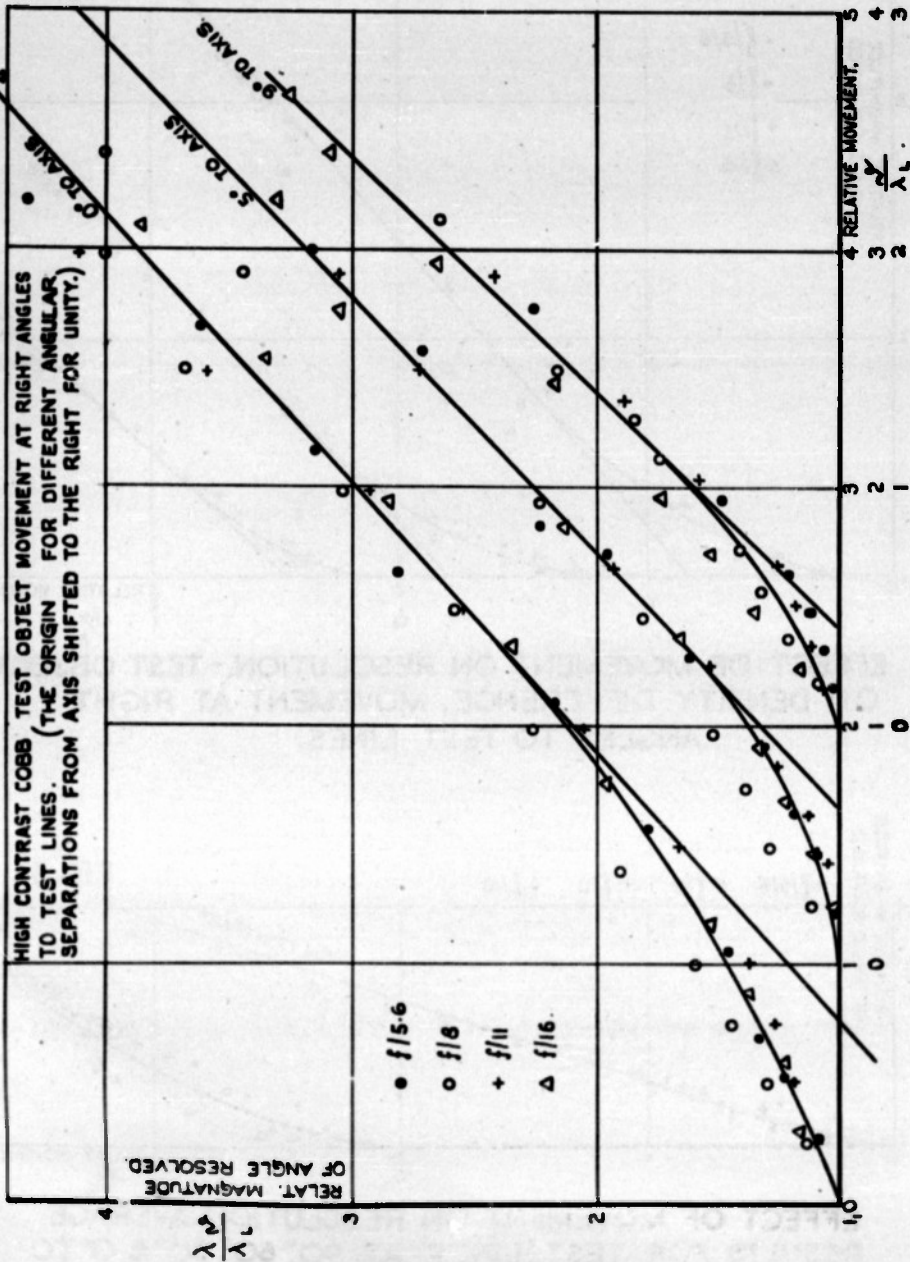

EFFECT OF MOVEMENT ON RESOLUTION

49-

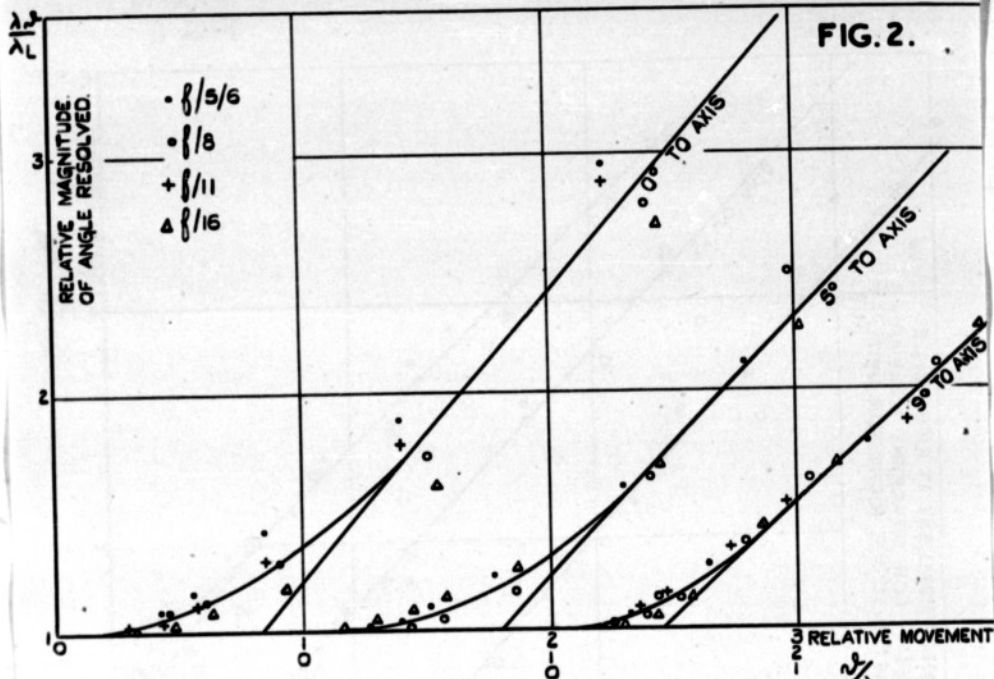

EFFECT OF MOVEMENT ON RESOLUTION.-TEST OBJECT. O/I DENSITY DIFFERENCE, MOVEMENT AT RIGHT ANGLES TO TEST LINES.

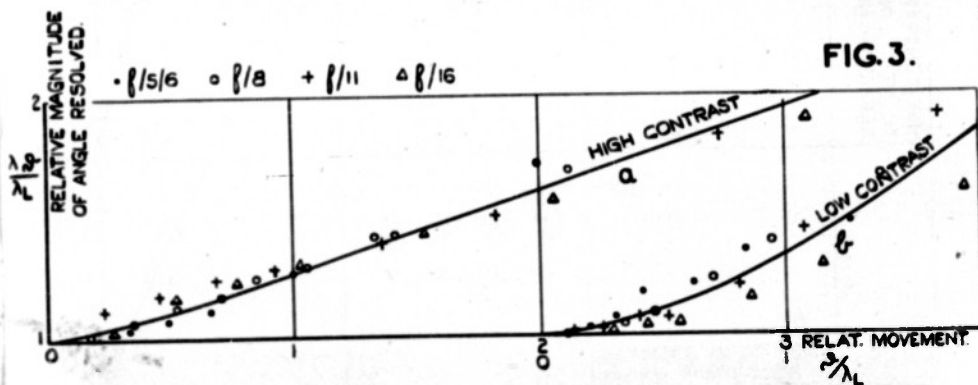

EFFECT OF MOVEMENT ON RESOLUTION. AVERAGE RESULTS FOR TEST LINES AT 90°, 60°, 30° & 0° TO MOVEMENT FOR CIRCULAR IMAGE AREA COVERING 9° FIELD.

FIG. 4.

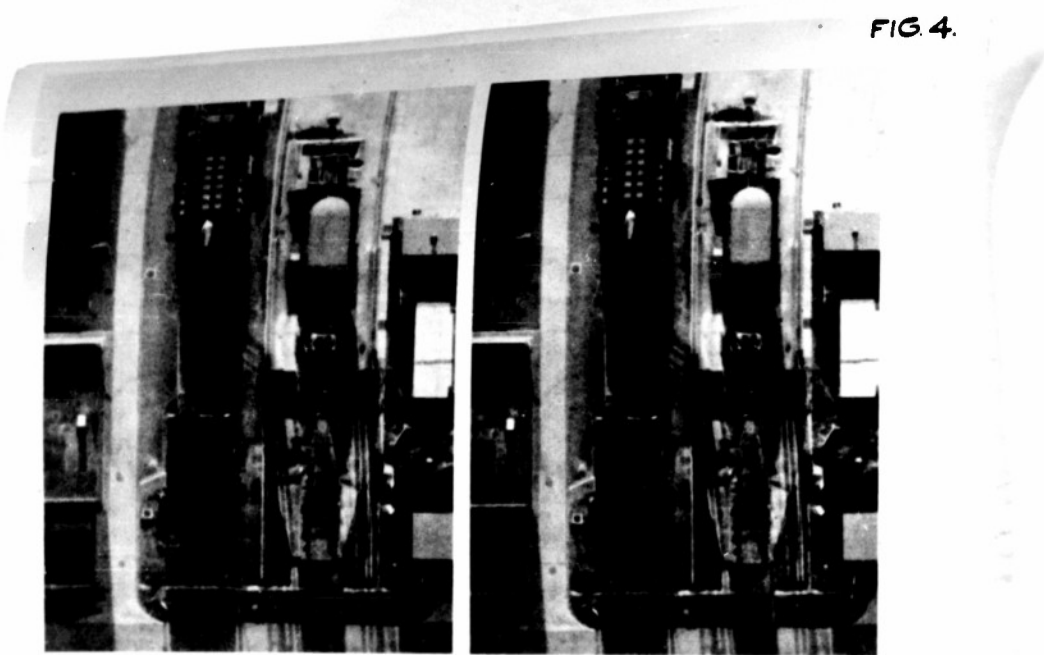

MOVEMENT = $0.6 \lambda L$



MOVEMENT COMPENSATED

EFFECT OF MOVEMENT ON RESOLUTION

MOVEMENT DURING EXPOSURE 0.6 OF THE DETAIL SIZE RESOLVED BY THE STATIONARY LENS (LIMITING ALLOWED AMOUNT OF MOVEMENT) EFFECT ON RESOLUTION JUST NOTICEABLE.

(ALTITUDE 6500' 200 M.P.H. GROUND SPEED: $1/400$ SEC EXPOSURE: 20° AVIAR $f/56$; MINUS BLUE FILTER; ENLARGED 8 DIAM)

ROYAL AIR FORCE ESTABLISHMENT
RESEARCH DIVISION
COPY NO. 67556
DATE 28. 1. 46

- 50 -

FIG. 5.

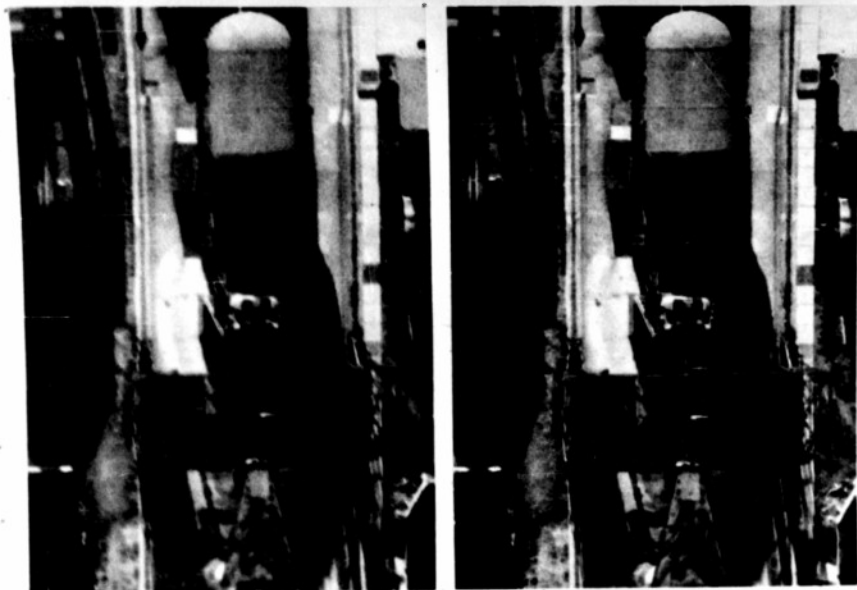

MOVEMENT 1/27L



MOVEMENT COMPENSATED

EFFECT OF MOVEMENT ON RESOLUTION.

MOVEMENT DURING EXPOSURE 1/2 X DETAIL SIZE RESOLVED BY
THE STATIONARY LENS. SIGNIFICANT REDUCTION IN RESOLUTION
(ALTIT. 3250': 200 M.P.H. GROUND SPEED: 1/400 SEC EXPOSURE:
20° AVIAR f/5.6: MINUS BLUE FILTER: ENLARGED 8 DIAM)

51-
ROYAL AIRCRAFT ESTABLISHMENT
COPY NEG. NO. 67557
DATE 28.1.46.

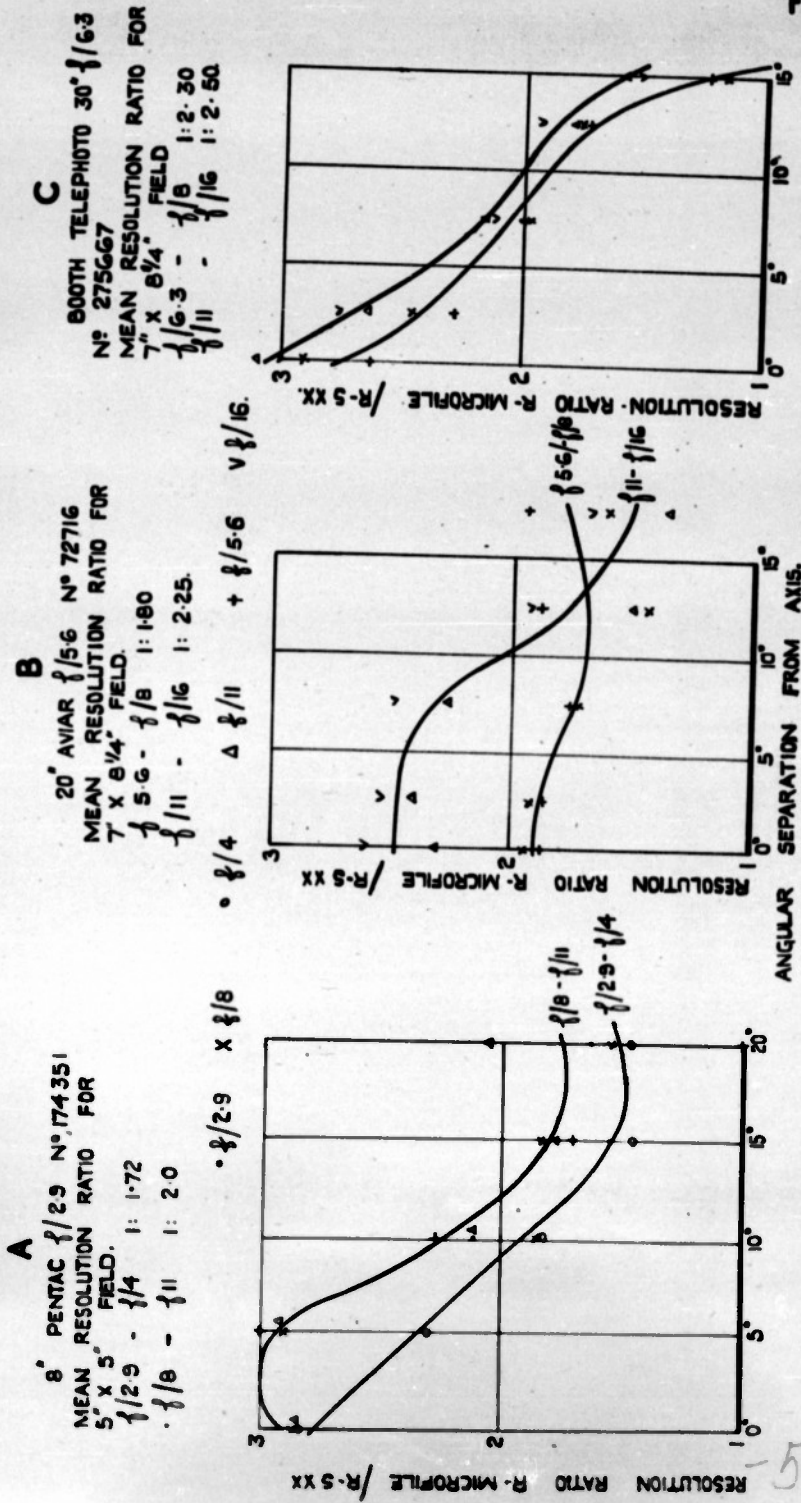

MICROFILM / SXX RESOLUTION RATIO.

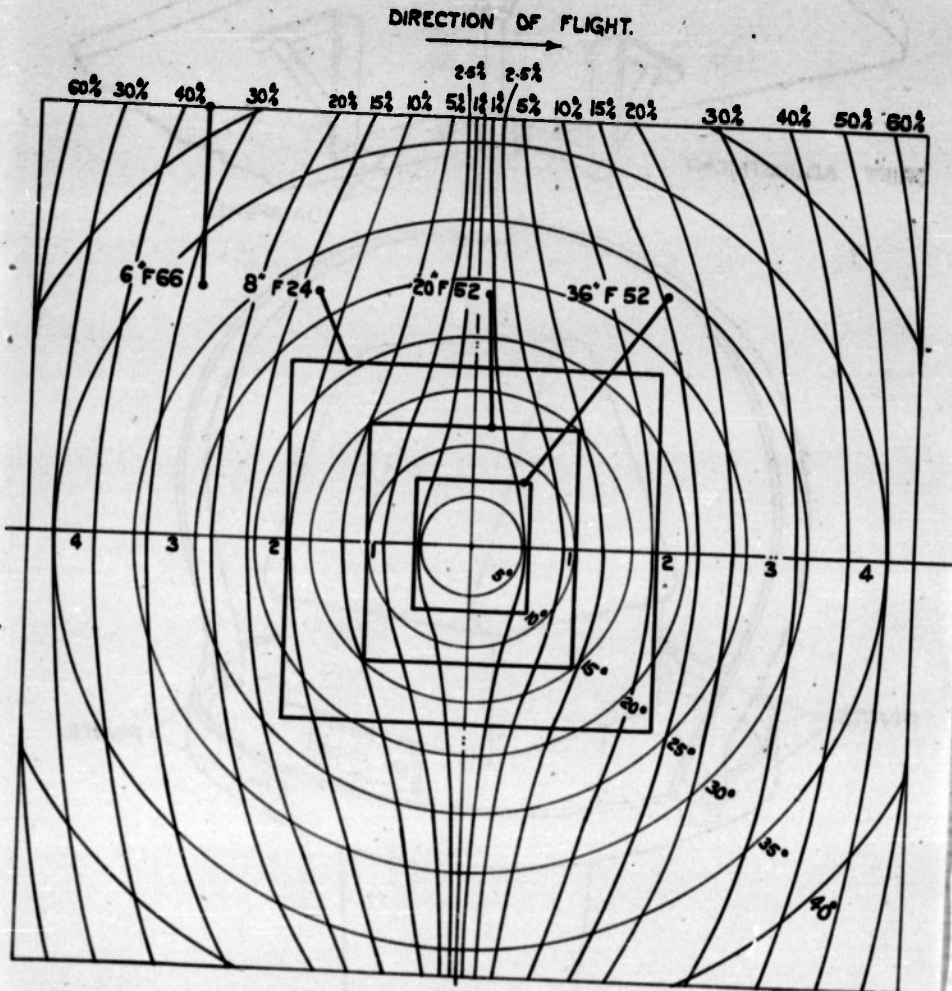

**ERROR IN MOVEMENT COMPENSATION OVER THE
IMAGE FIELD.**

$(\frac{1}{2} \frac{v}{v_0} \times 100)$

NR. PH. 8529...

REPORT: PH. 1.
FIG. 9.

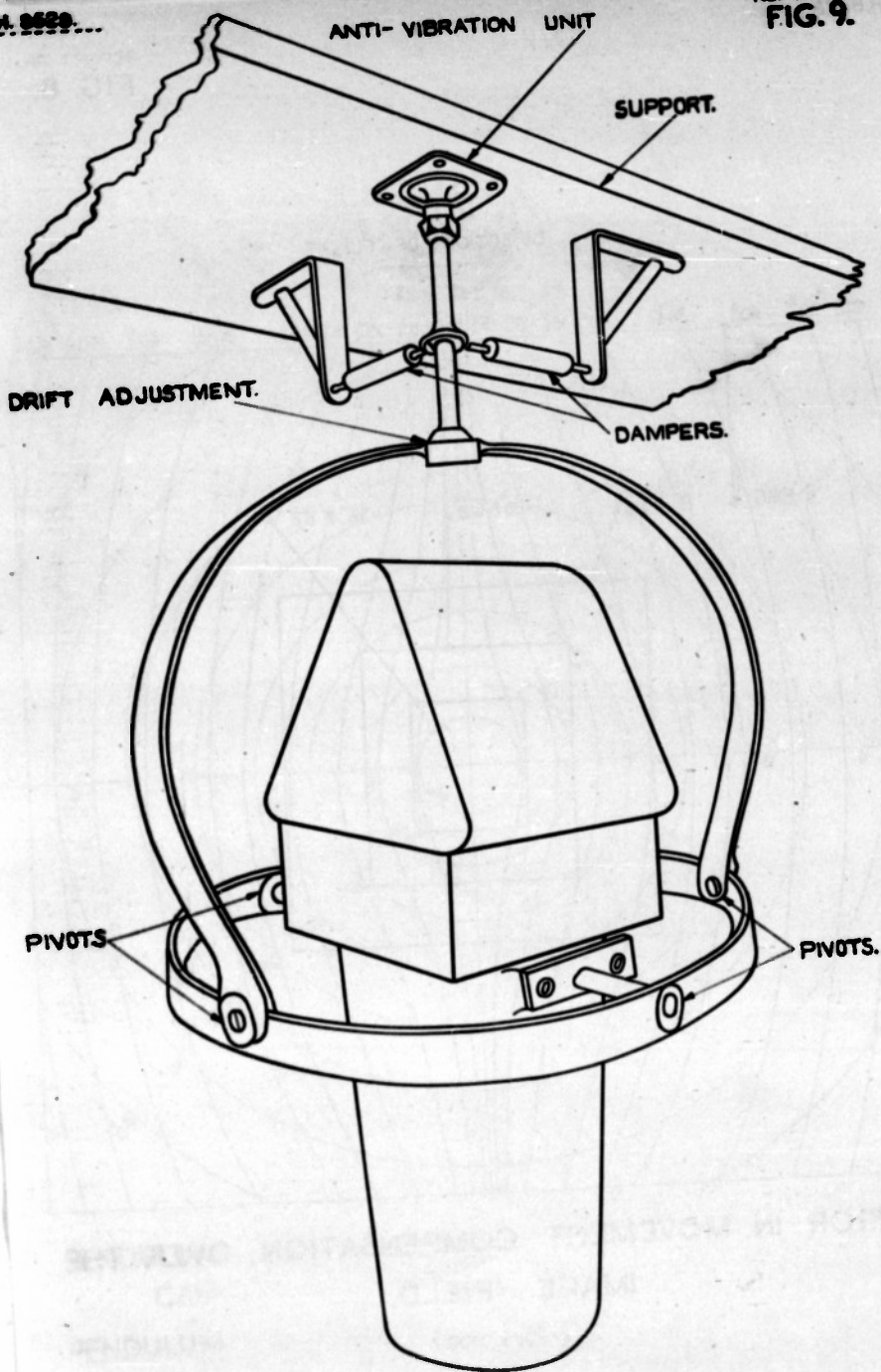

PENDULUM SUSPENSION FOR THE GYRO CONTROLLED
CAMERA MOUNTING (CONTROLS NOT SHOWN.)

53A-

FIG 10



A. STANDARD PANCHROMATIC FILM: f/8: 1/400 SEC: MINUS BLUE FILTER:
STANDARD F52 CAMERA: STANDARD TYPE 38 MOUNTING.



B. EXPERIMENTAL FINE GRAIN FILM: f/11: 1/70 SEC: MINUS BLUE FILTER:
MOVING FILM MAGAZINE: GYMBAL MOUNTING.

54

IMPROVED RESOLUTION BY MOVEMENT COMPENSATION
20" AVIAR LENS: 10000' ALTITUDE: 240 MPH GROUND SPEED:
MAGNIFICATION 10X: AXIAL IMAGE.

PHOTO RESEARCH ESTABLISHMENT
PHOTOGRAPHIC DIVISION
CORP. NO. 67558
28 1-46

FIG. 11



A



B

IMPROVED RESOLUTION BY MOVEMENT COMPENSATION

THE SAME CONDITIONS AS IN FIG. 10 BUT IMAGE
90° OFF OPTIC AXIS

55-

ROYAL AIRCRAFT ESTABLISHMENT
REPORT NO. 67559
1946 28 1-46

FIG.12.



A. STANDARD PANCHROMATIC: $1/400$ SEC: $f/8$: MINUS BLUE FILTER:
STANDARD F52 CAMERA: TYPE 36 MOUNTING.

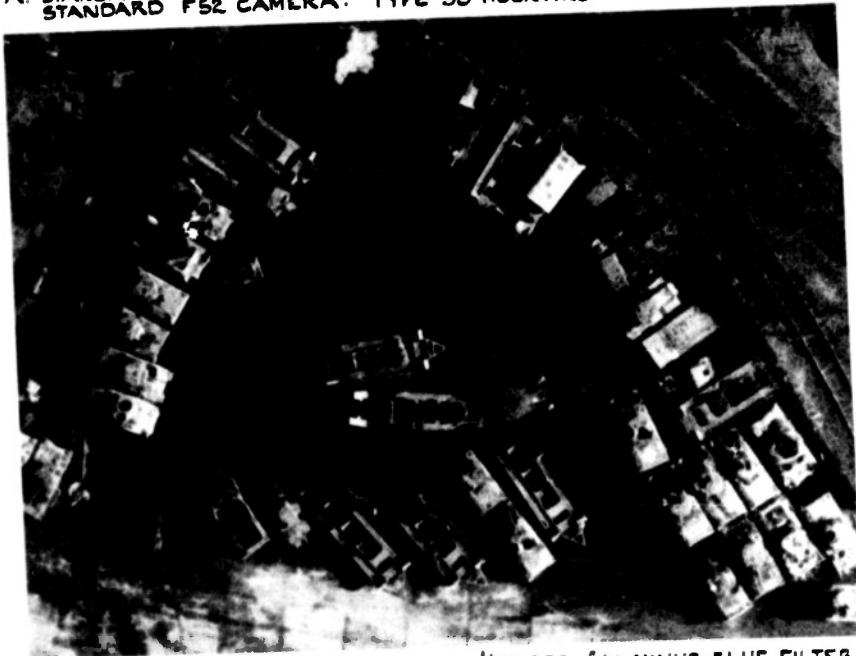

B. EXPERIMENTAL FINE GRAIN FILM: $1/70$ SEC $f/11$: MINUS BLUE FILTER:
MOVING FILM MAGAZINE: GYMBAL MOUNTING.

IMPROVED RESOLUTION BY MOVEMENT COMPENSATION

36" TELEPHOTO LENS: 15000' ALTITUDE: 210 MPH GROUND SPEED:
MAGNIFICATION 15 X: AXIAL IMAGE.

56-
SERIAL AIRCRAFT ESTABLISHMENT
COPY NO. 67560
DATE 28-1-46

FIG. 13.



A

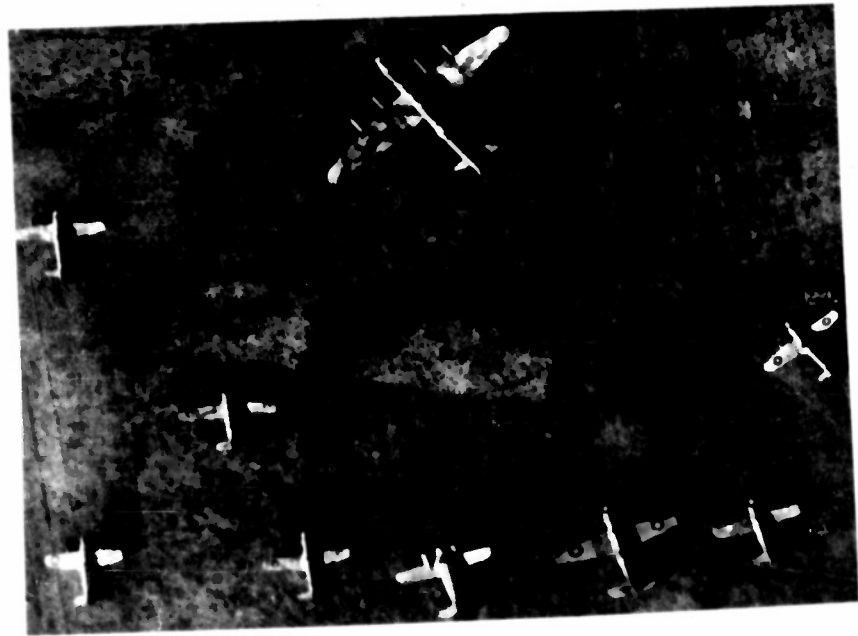

B

IMPROVED RESOLUTION BY MOVEMENT COMPENSATION
THE SAME CONDITIONS AS IN FIG. 12 BUT IMAGE
4° OFF OPTIC AXIS MAGNIFICATION 10 X

57-

QUAL. AIRCRAFT ESTABLISHMENT
COPY NO. 87561
18 1 46

FIG. 14.

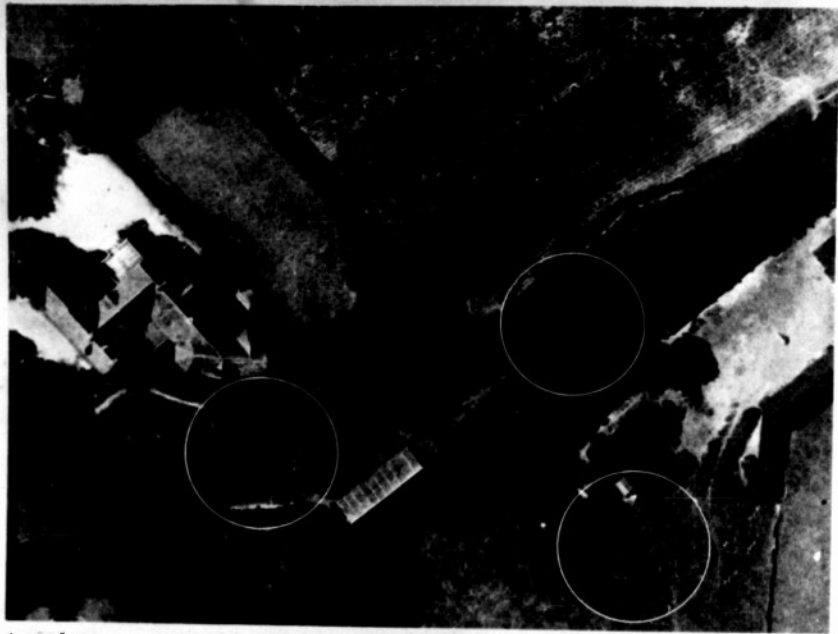

A. 20" AVIAR. LENS: $f/11$: MINUS BLUE FILTER: $1/400$ SEC: STANDARD F52. CAMERA.
MAGNIFICATION 8X

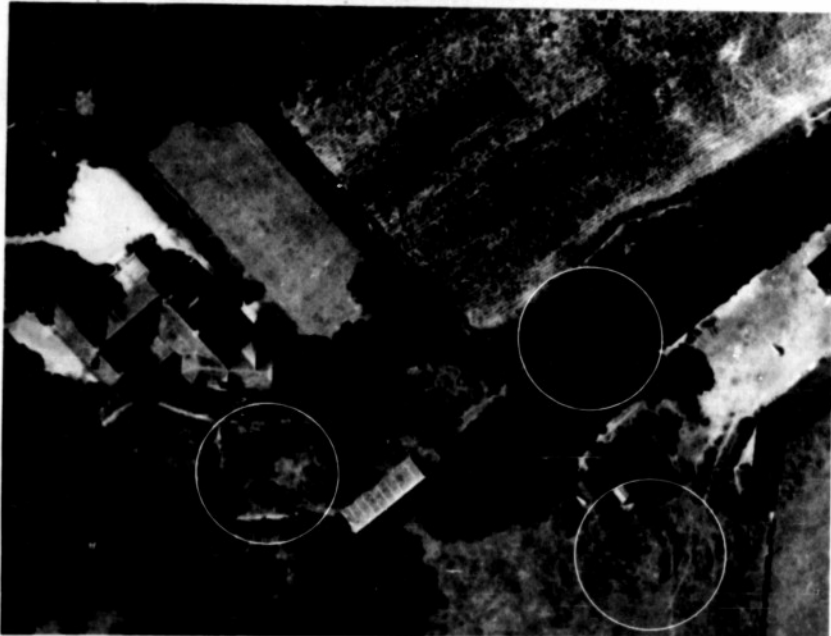

B. 5" PENTAC: $f/8$: MINUS BLUE FILTER: 0.09 SEC. GYRO STABILISED F24 CAMERA
MOVEMENT COMPENSATION: MAGNIFICATION 20X

IMPROVED RESOLUTION IN STABILISED CAMERA.

10000 ALTITUDE: 210 MPH GROUND SPEED.

58-

ROYAL AIR FORCE ESTABLISHMENT
COPY NO. 67562
DATE 25-1-46

FIG 15



IMPROVED RESOLUTION IN STABILISED CAMERA
CONDITIONS AS FIG 14

59-

SIGNAL SECRETARY ESTABLISHMENT
COPY NO. 87563
DATE 28-1-48

REPORT PH. I.
FIGS. 17A & 17B.

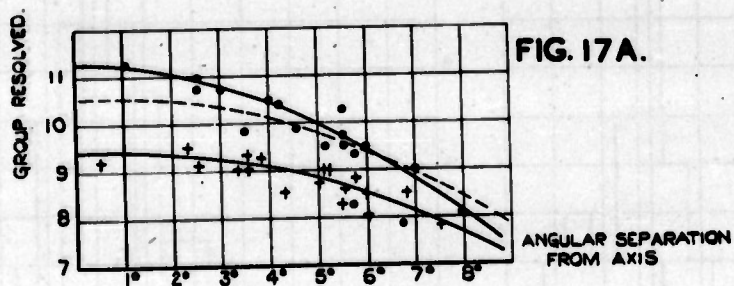

- + SXX FILM STANDARD CAMERA
- FINE GRAIN FILM, MOVEMENT COMPENSATION

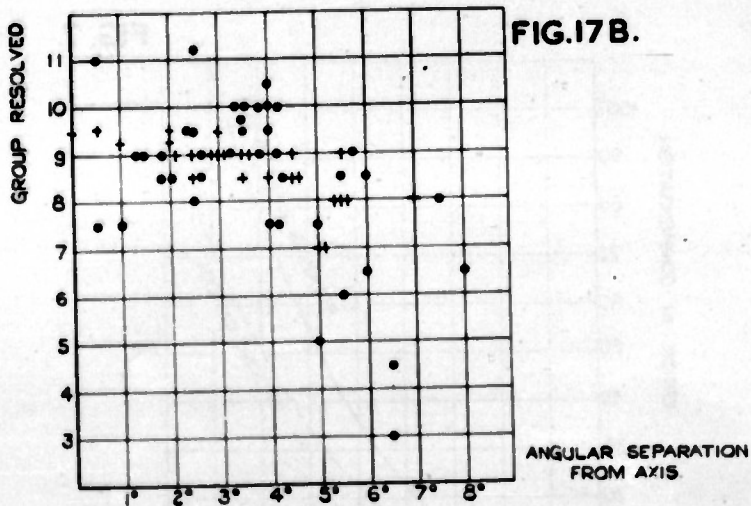

RESULTS OF AIR TEST
RESOLUTION - IMAGE ANGLE.

-60-

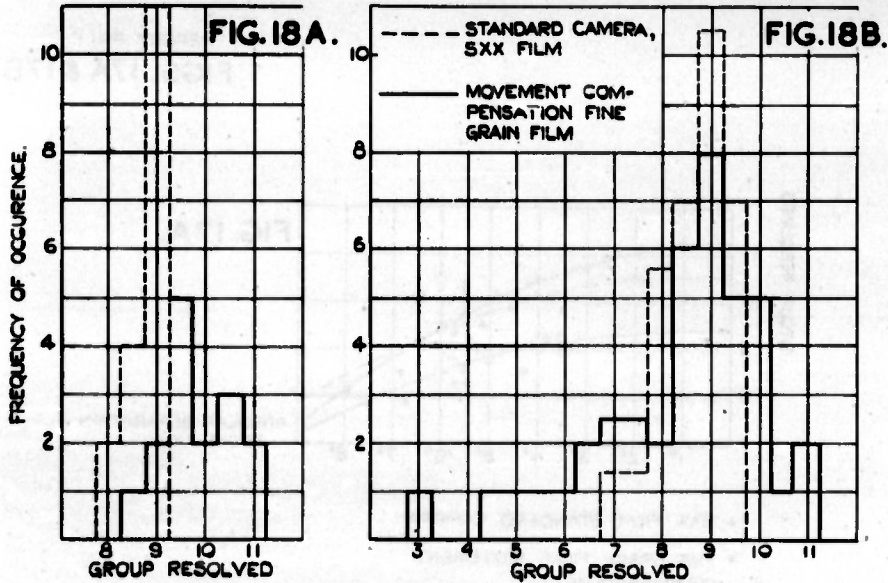

**FREQUENCY DISTRIBUTION OF RESULTS
RESOLUTION TESTS**

FIG. 7.

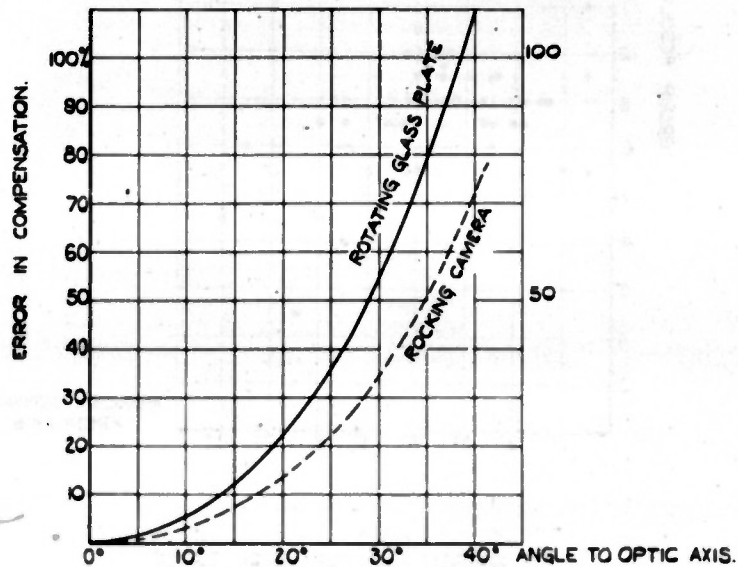

**ERROR IN MOVEMENT COMPENSATION, ROTATING
GLASS PLATE AND ROCKING CAMERA**

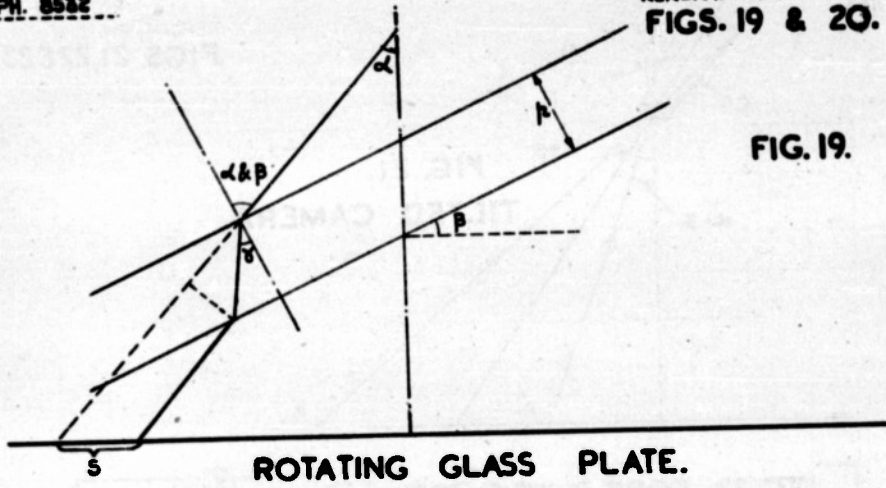

FIG. 19.

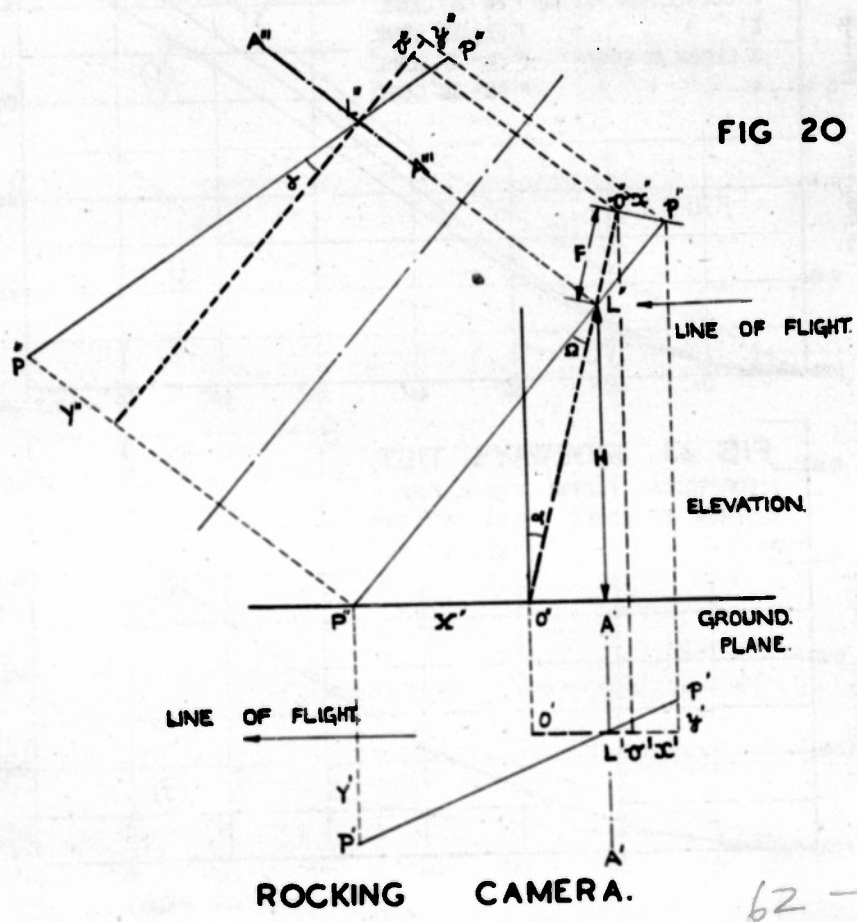

FIG 20

ROCKING CAMERA.

62 -

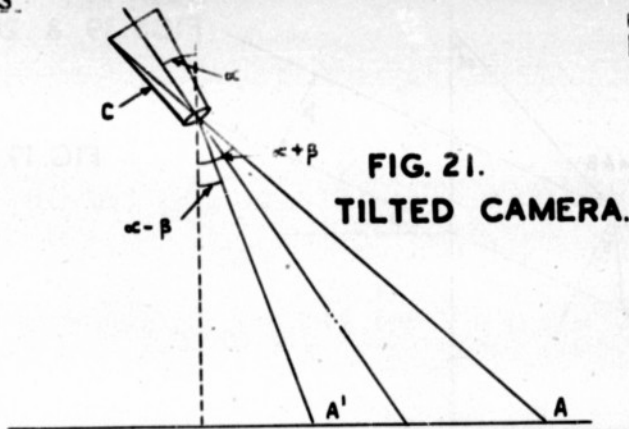
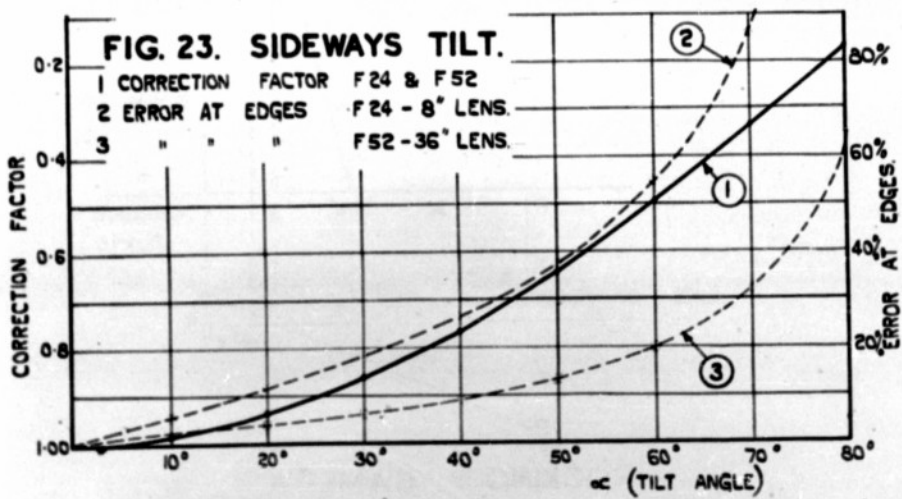
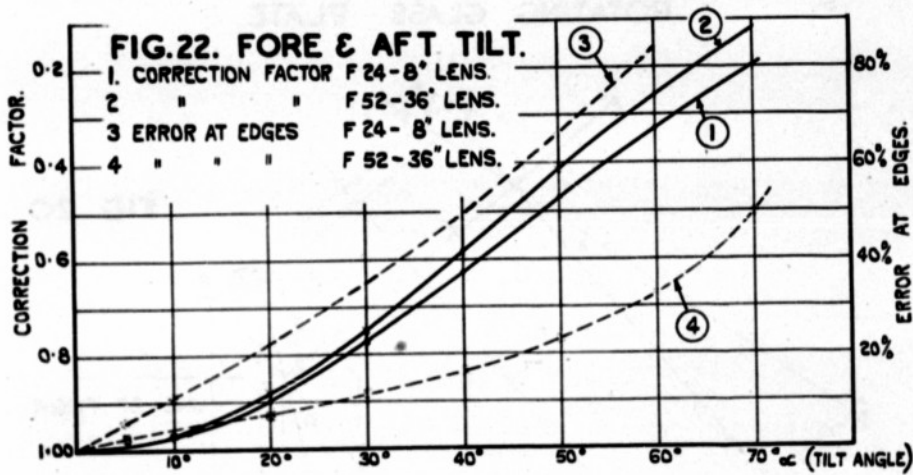
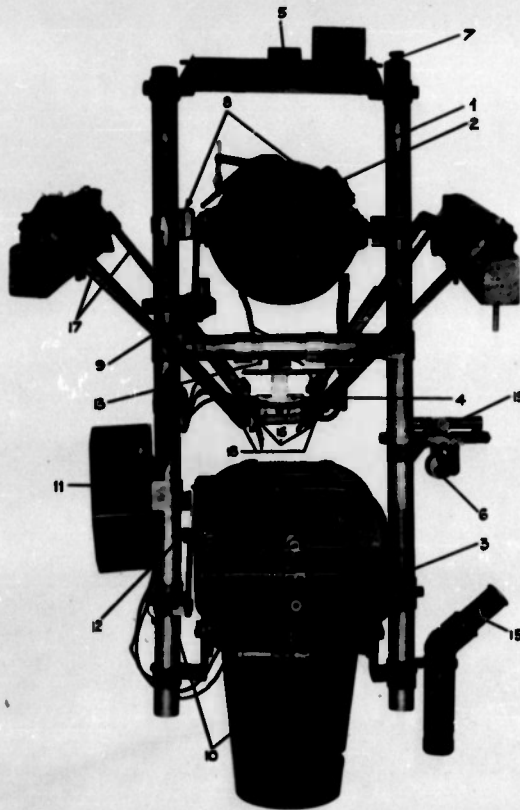

FIG. 21.
TILTED CAMERA.



63-

FIG 24.



STABILISED CAMERA MOUNTING

- | | |
|---|--------------------------------------|
| 1. H-SHAPED STEEL TUBING FRAME | 11. ROCKING MECHANISM. |
| 2. GYROSCOPE IN EVACUATED SPHERE | 12. ROCKING CAM |
| 3. F24 CAMERA | 13. LOCATION OF THE VERTICAL SHAFT |
| 4. BALL RACE GYMBAL | 14. LOCKING NUT FOR DRIFT ADJUSTMENT |
| 5. BALANCING WEIGHT. | 15. SIGHTING TELESCOPE |
| 6. BALANCING WEIGHT | 16. SUPPORTING BARS |
| 7. KNOB CONTROLLING BALANCING WEIGHT | 17. RUBBER CORDS. |
| 8. SOFT RUBBER BUSHINGS SUPPORTING THE GYRO | 18. HYDRAULIC DAMPERS |
| 9. HYDRAULIC DAMPER. | 19. SPIRIT LEVELS. |
| 10. CAMERA SUSPENSION HINGES. | |

6744
1946

64-



FIG. 16

F.24. CAMERA 8" 1/800 SEC f/11 SUPER XX FILM MAGNIFICATION 20X.

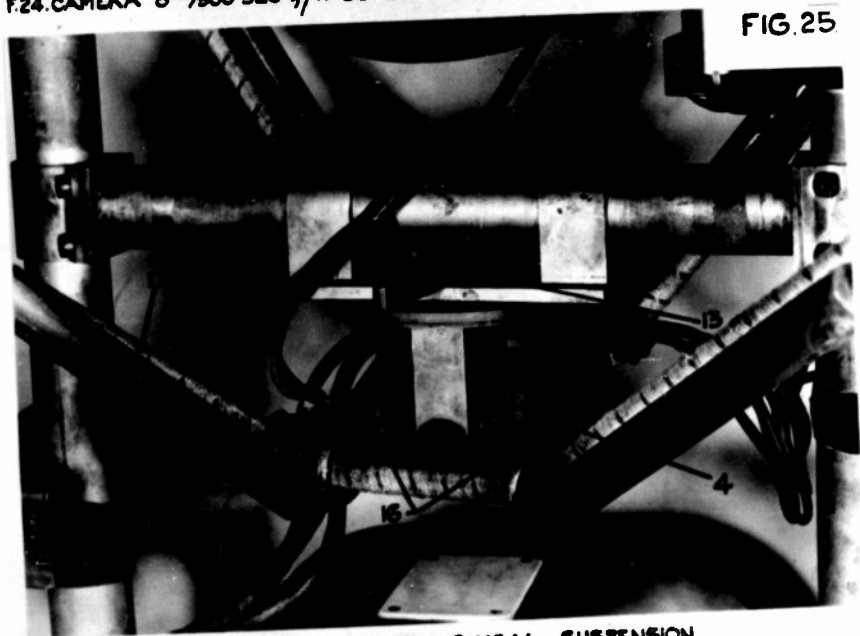
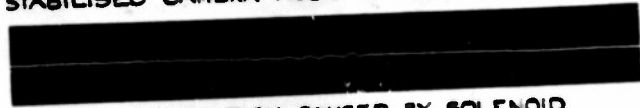

FIG. 25

STABILISED CAMERA MOUNTING - GIMBAL SUSPENSION.



TRACK OF VIBRATION CAUSED BY SOLENOID ACTION (MAGNIFICATION 10X)

FIG. 26

ROYAL AIRCRAFT ESTABLISHMENT
PHOTOGRAPHIC DEPARTMENT
COPY NO. 67565
DATE 28-1-46

65-

REEL - C

3 4 3

A.T.I.

9 5 2 5

ATI 9525

Restricted

Copies obtainable from ASTIA by
U.S. Government agencies only

Subj: Suppression of image movement in air photography.

OA: Royal Aircraft Establishment, Farnborough, England

April'46. 66pp. Photos, Tables, Graphs.

Division: Photography (26)

Section: Aerial Photography (1)

Restricted

ATI 9525

~~CONFIDENTIAL~~
(Restricted)

Copies obtainable from ASTIA by
U.S. Government agencies only

Subj: Suppression of image movement in air photography.

OA: Royal Aircraft Establishment, Farnborough, England

April '46. 66pp. Photos, Tables, Graphs.

Division: Photography (26) ⁵⁶

Section: Aerial Photography (1) ₂

~~CONFIDENTIAL~~
Restricted

EO 10501 dtd 57 Nov 53

E.O. 10501 dcl

5 Nov. 53 - 28 January

C

Orig. Agcy. ~~North Atlantic Division~~ Series ~~1000~~

Author ~~None~~

Date ~~28 Feb 53~~ ADD No. ~~152 923~~

Division _____ Section _____

File No. _____ Classif. ~~Secret~~

Title ~~SECRETION OF THE ...~~



Documentation Centre
Knowledge Services
[dstl] Defence Research
Agency
Box
507 000
Cranfield, Bedfordshire
MK43 0QJ
Tel: +44 (0)1235 437373
Fax: +44 (0)1235 437374

Defense Technical Information Center (DTIC)
8725 John J. Kingman Road, Suit 0944
Fort Belvoir, VA 22060-6218
U.S.A.

AD#: ADA800711

Date of Search: 19 Oct 2009

Record Summary: AVIA 6/19332, AVIA 6/17013

Title: Suppression of image movement in air photography
Availability Open Document, Open Description, Normal Closure before FOI Act: 30 years
Former reference (Department): REPORT PH 1
Held by The National Archives, Kew

This document is now available at the National Archives, Kew, Surrey, United Kingdom.

DTIC has checked the National Archives Catalogue website (<http://www.nationalarchives.gov.uk>) and found the document is available and releasable to the public.

Access to UK public records is governed by statute, namely the Public Records Act, 1958, and the Public Records Act, 1967.

The document has been released under the 30 year rule.

(The vast majority of records selected for permanent preservation are made available to the public when they are 30 years old. This is commonly referred to as the 30 year rule and was established by the Public Records Act of 1967).

This document may be treated as UNLIMITED.