

NATIONAL ADVISORY COMMITTEE FOR AERONAUTICS

# WARTIME REPORT

ORIGINALLY ISSUED  
February 1942 as  
Advance Restricted Report

AN INVESTIGATION OF DIFFUSER-RESISTANCE COMBINATIONS  
IN DUCT SYSTEMS

By Charles H. McLellan and Mark R. Nichols

Langley Memorial Aeronautical Laboratory  
Langley Field, Va.

# NACA

WASHINGTON

NACA WARTIME REPORTS are reprints of papers originally issued to provide rapid distribution of advance research results to an authorized group requiring them for the war effort. They were previously held under a security status but are now unclassified. Some of these reports were not technically edited. All have been reproduced without change in order to expedite general distribution.

AN INVESTIGATION OF DIFFUSER-RESISTANCE COMBINATIONS  
IN DUCT SYSTEMS

By Charles H. McLellan and Mark R. Nichols

SUMMARY

An investigation was conducted to determine the properties of diffuser-resistance combinations. This work applies to the design of airplane cooling ducts in which air is expanded in front of resistances, such as radiators, oil coolers, intercoolers, or the cylinders of an air-cooled engine. The magnitude of the resistance and the boundary layer present at the entrance of the diffuser were systematically varied for each of a series of diffuser shapes for expansion ratios of 2:1 and 3:1. The effects of these variations on the diffuser-resistance efficiencies, on the diffuser efficiencies, and on the velocity distributions across the resistances were studied. Good diffuser shapes were determined for a wide range of conditions.

The results show that the presence of a resistance at the rear of a diffuser allows the expansion to be made much more rapidly for a given expansion energy loss than is possible with a diffuser discharging into a straight exit tube. The greater the resistance, the higher is the expansion rate that can be used for a specified expansion energy loss. The results also show the large effect of the entrance boundary layer. The initial increments cause a rapid decrease in the diffuser efficiency obtained by a given diffuser shape. Further increases have little additional effect.

INTRODUCTION

Incorporated in a modern airplane are a great many ducts that convey air to heat exchangers, compressors, carburetors, and similar devices. It is always necessary in this process to increase or decrease the air velocity as the occasion demands. To increase the velocity in an efficient manner is a simple matter; but to decrease it efficiently in actual airplane installations is often

more difficult because there usually is insufficient space to house diffusers of the low expansion rates commonly considered to be desirable.

A number of methods of increasing the rates of expansion have been tried with varying degrees of success, such as the use of vanes or boundary-layer control. Fortunately, high rates of expansion may also be used with good efficiencies by taking advantage of the resistances to the flow imposed by a heat exchanger. This arrangement eliminates the necessity of using guide vanes or boundary-layer control.

In experiments conducted several years ago at Langley Memorial Aeronautical Laboratory with a duct supplying air to a radiator, it was discovered that the flow did not separate from the diffuser in front of the radiator even though the expansion rate was unusually high. This finding suggested the present basic investigation for determining the properties of diffusers followed by resistances.

This investigation was limited to conical diffusers of expansion ratios of 2:1 and 3:1. Six resistances having conductivities ranging in magnitude from that of a radial engine to a radiator were covered. The diffuser shapes and the rates of expansion were varied through wide ranges. The effect of an initial boundary layer of various thicknesses was also studied.

#### APPARATUS AND METHODS

The tests were conducted with a blower that sucked air successively through an entrance tube, a diffuser, a resistance, a damping chamber, and a venturi for measuring the quantity. (See fig. 1.) Sucking the air through the system allowed the condition of the air at the entrance of the diffuser to be determined by the entrance tube alone. The thickness of the boundary layer at the beginning of the diffuser was a function only of the Reynolds number, the entrance-tube length, and the smoothness of the entrance tube.

The Reynolds number of these tests varied between 250,000 and 600,000, based on the diameter of the entrance tube.

Preliminary tests indicated that the effect of tube length on the behavior of the diffusers was quite noticeable for tubes of 6 diameters and less in length; longer tubes had little additional effect. The length of the entrance tubes was therefore confined to lengths ranging between 0.12 and 6 diameters. The free air was allowed to flow into the pipe with the aid of a well-rounded entrance bell.

The diffuser shapes (fig. 2) were formed of plasticine. Preliminary tests were made using a large variety of shapes, but these shapes were later limited to a few types that were found to be satisfactory.

A series of interchangeable screens (table I) were used to represent the resistances encountered in airplane design. This arrangement satisfactorily represents resistances that have a series of air passages parallel to the direction of flow. (Most radiators and oil coolers are of this type.) These resistances may be represented by a screen because little radial flow can take place through either the screen or the resistance and the velocity distribution is the same at the rear as at the front of the resistance in both cases.

Resistances such as oil coolers have often been represented by a series of screens spaced over the actual length required by the resistance. Such an arrangement does not represent the actual flow through the resistance, as radial flow can take place between the layers of screen and the velocity distribution is different at the rear of the resistance than at the front. Some types of resistances cannot be represented satisfactorily by screens whether they are all in one plane or distributed over the length of the space required by the actual resistance. A resistance of this type is the tubular intercooler, in which the center line of the intercooler tubes is perpendicular to the direction of the cooling-air flow. In this case the resistance itself allows flow perpendicular to the duct axis through the resistance.

After passing through the resistance, the air passed through a short length of straight tube and then into a damping chamber. (See fig. 1.) The purpose of this chamber which consisted of a conical expansion with a screen at the largest diameter and a converging section directing the air to the calibrated venturi was to damp out any oscillations in the air before it reached the calibrated

venturi used to determine the quantity of flow. A constant calibration of the venturi was maintained by the use of this damping chamber.

In order to obtain the efficiencies of the system it was necessary to measure the total and static pressures both before the expansion and after the resistance. (See fig. 2.) The total and static pressures were not measured at the front face of the resistance because accurate measurements could not be obtained at this point.

The total-pressure survey before the diffuser was made with a fine wedge-shaped total-pressure tube with an opening of about 0.005 by 0.05 inch and an outside size of 0.010 by 0.06 inch. This instrument allowed total-pressure measurements to be taken within 0.005 inch of the wall. The exact location of the total-pressure tube was determined by a micrometer screw as it traversed the entrance tube. In most cases the static pressure in the entrance tube was measured by surface orifices in the tube. This method was sufficiently accurate to be used in determining both the velocity distribution of the diffuser entrance and the entrance-tube losses even for the short entrance tubes since the large entrance bells caused a nearly uniform induction of the air into the entrance tube.

The total and static pressures behind the resistance were measured by a stationary rake consisting of five static tubes and nine total-pressure tubes and extending from the wall to the center line of the exit duct. A location 1 inch back of the screen was chosen because the velocity distribution here would be, for all practical purposes, the same as the distribution immediately in front of the resistance. A rake closer to the resistance might have been influenced by the individual wires of the screen.

## ANALYSIS

### Symbols

The following symbols are used:

A area of duct section

d diameter of entrance tube

- D diameter of duct
- H total pressure
- K conductivity of resistance
- l length of entrance tube
- p static pressure
- $\Delta p_r$  pressure drop across resistance for given quantity of air transmitted per unit time for uniform flow
- q dynamic pressure
- Q quantity of air passing through duct section per unit time
- r radius
- R radius of duct
- $R_u$  radius between entrance tube and diffuser cone  
(See fig. 2.)
- $R_d$  radius between conical portion of diffuser and front of resistances (See fig. 2.)
- V velocity of air
- $V_D$  velocity at center of duct
- $\rho$  mass density of air
- $2\theta$  equivalent diffuser cone angle (See fig. 2.)
- $2\beta$  diverging angle of straight conical section of diffuser (See fig. 2.)
- $\eta_e$  diffuser efficiency
- $\eta_t$  diffuser-resistance efficiency

An average value obtained from an integration against the quantity of flow across the stream is shown by a bar above the symbol. Subscripts 1, 2, and 3 refer to the corresponding sections in figure 2.

### Derivation of Formulas

The coefficient  $\eta_e$  represents the efficiency of the conversion of kinetic energy of the air entering the diffuser to potential energy. From this definition the efficiency is

$$\eta_e = \frac{\int_0^{Q_2} p_2 dQ_2 - \int_0^{Q_1} p_1 dQ_1}{\int_0^{Q_1} q_1 dQ_1 - \int_0^{Q_2} q_2 dQ_2}$$

When the small change in air density due to the expansion is neglected and average pressures are substituted for integrated pressures, the efficiency becomes

$$\eta_e = \frac{\bar{p}_2 - \bar{p}_1}{\bar{q}_1 - \bar{q}_2}$$

The coefficient  $\eta_t$  is an over-all efficiency of the expansion-resistance system. The useful work of the system is regarded as the work expended in forcing the air through the resistance for uniform flow. The work expended is the loss in energy of the air from the entrance of the diffuser to the rear of the resistance.

Therefore,

$$\eta_t = \frac{\Delta p_r \bar{q}_3}{\int_0^{Q_1} H_1 dQ_1 - \int_0^{Q_3} H_3 dQ_3}$$

or

$$\eta_t = \frac{\Delta p_r}{\bar{H}_1 - \bar{H}_3}$$

The conductivity is a flow coefficient defined as

$$K = \frac{Q}{A_2 \sqrt{2\Delta P_r / \rho}}$$

and since  $Q = A_2 \bar{V}_2$

$$K = \sqrt{\bar{q}_2 / \Delta P_r}$$

The ratio of  $\Delta P_r / \bar{q}_2$  is frequently used in place of the conductivity. The relation between  $\Delta P_r / \bar{q}_2$  and  $K$  is shown in figure 3.

### Conversion of $\eta_t$ to $\eta_e$

The diffuser efficiency  $\eta_e$  could not be directly obtained in these experiments because of the difficulties involved in obtaining measurements of pressures directly in front of the resistance. A mathematical method was therefore devised to obtain  $\eta_e$  from  $\eta_t$ , the over-all efficiency of the system. The relation between these two efficiencies was found to be

$$\eta_e = 1 - \frac{1 - \eta_t}{\eta_t K^2 [(A_2/A_1)^2 - 1]}$$

The conversion chart (fig. 4) was developed from this relationship.

This conversion method is based on the assumption that the pressure drop across the resistance is the same under test conditions as it would be for uniform flow. The conversion, therefore, is inaccurate where the velocity distribution through the screen is nonuniform. The diffuser efficiencies obtained by this conversion method when the velocity distribution is poor will be lower than the actual efficiencies. Fortunately, all the diffusers except those with very high angles and with large values of conductivity for the 3:1 expansion ratio had good

velocity distributions through the resistance. The error incurred in using the conversion chart or the equation is therefore very small except in the few cases just mentioned.

## RESULTS AND DISCUSSION

The velocity distribution or boundary-layer thickness at the entrance of the diffuser for the various lengths of entrance tube are shown in figures 5 and 6. The length of the entrance tube had a considerable effect on the diffuser-resistance efficiency, as is clearly shown in figure 7. The efficiency decreased very rapidly at first as the entrance length was increased but, as the length became greater, the effect of length on efficiency became smaller. At a length of about six times the diameter of the entrance tube the effect of further increase was negligible. Apparently, the initial boundary layer was the most detrimental and further increase in thickness had little effect.

The conductivity of the resistance is one of the main variables affecting the efficiency of the diffuser-resistance system. Decreasing the conductivity increases the efficiency in two ways. First, it causes an improvement in the diffuser efficiency because the damming-up effect of the stream due to the resistance results in spreading the stream and retards separation; and, second, it raises the pressure drop across the entire system, thus making the losses in the diffuser alone a smaller portion of the total losses across the diffuser-resistance system. The second effect, of course, is algebraic and does not indicate an improvement in the flow of the diffuser. The effects of the conductivity on the maximum diffuser-resistance efficiency are shown in detail in figures 8 and 9.

The values of the conductivity  $K$  for several of the resistances encountered in airplane installations may be of interest. Oil coolers and radiators have values of the order of 0.4 while intercoolers are usually in the neighborhood of 0.2. Modern two-row radial aircraft engines of 1000 to 2000 horsepower have  $K$  values ranging from 0.10 to 0.17, based on the over-all diameter of the engine. If these  $K$  values are based on the portion of the frontal area of the engine through which the cooling air passes, these values would range from 0.25 to 0.4.

The most important variable, the only one over which much control can be had in actual installations, is the diffuser shape. In this investigation the diffuser shape was defined by three quantities: a radius  $R_u$  at the entrance of the diffuser, an angle  $2\beta$  of a cone tangent to  $R_u$ , and a radius  $R_d$  tangent to the cone through the intersection of the diffuser with the large diameter exit tube. (See fig. 2.) At high angles the conical section disappeared and  $R_d$  became tangent to  $R_u$ .

The radius at the diffuser entrance was found to have only a small effect. From the tests made, apparently the only requirement of  $R_u$  is that it should be large enough to remove the abruptness of the corner. The value used was found to satisfy this requirement.

A study of the requirements for  $R_d$  indicates that a value should be used which would keep the diffuser walls within the region influenced by the high static pressure immediately in front of the resistance. The value of the  $R_d$  used was obtained from a series of tests which showed that a value of about  $0.33D_2$  was apparently slightly better than the other radii tested. This value gave satisfactory results until the diffuser became so short that the beginning of the curve was very abrupt. Beyond this point  $R_d$  was allowed to be equal to  $0.167D_2$ .

The angle  $2\beta$  of the cone had a large effect on the diffuser-resistance efficiency. This effect is shown in figures 10 to 13. For a given effective angle, conductivity, and expansion ratio, the efficiency was plotted against the cone angle  $2\beta$ . These curves show that the maximum possible value of  $2\beta$  produced the highest efficiency at low effective angles. At larger effective angles the efficiency was found to be a maximum at values of  $2\beta$  considerably below the effective angle  $2\theta$ . These curves also show that the losses in over-all efficiency are not large if  $2\beta$  is varied slightly from the value for maximum efficiency, except at high conductivities.

Figures 14 and 15 show the diffuser shapes that provided the highest efficiency of the ones tested. These shapes were obtained from an extensive preliminary investigation and are believed to have very nearly (if not

actually) the maximum efficiency that can be obtained without the use of diffusers embodying boundary-layer control or other aids to diffusion.

The velocity and static-pressure distributions immediately behind the resistance are shown in figure 16 for sample cases of the optimum diffuser forms presented in figures 14 and 15. The velocity-distribution measurements show that the flow was nearly uniform through the resistance in all but a few cases in which the conductivity was high and the expansion was made at a high angle, such as the two conditions of high conductivity ( $K$  of nearly 0.6) shown in figure 16(e) for  $2\theta = 64.8^\circ$  and  $A_2/A_1 = 3$ . The velocity-distribution curves were very good for all the resistances used with the diffuser forms shown in figures 14 and 15 that had expansion angles less than  $30^\circ$  and were also very good for the high-angle diffuser forms tested in conjunction with the high-resistance screens. The static distribution plots show that there is little radial flow through the screens, even at high conductivities, and that this flow becomes less and less as the conductivity is decreased.

It may be noted that the velocity distributions in figure 16 do not average exactly one largely because the average velocity is calculated from the dynamic pressure in the calibrated venturi rather than from the integrated average of the local velocities.

The efficiencies of the diffuser-resistance combinations are presented in figures 17 and 18 for the two expansion ratios. Those for the 2:1 expansion ratio are very high at low effective angles. No appreciable decrease occurs for angles up to about  $30^\circ$ , except for the conductivity of 0.6 with a long entrance tube (thick boundary layer at the diffuser entrance). At angles above  $30^\circ$  the efficiencies drop off considerably for the higher conductivities; but for  $K = 0.2$  the efficiencies remain above 95 percent over the entire range tested. This result, of course, does not mean that the diffuser efficiencies will be high but that the diffuser losses will be very small in comparison with the losses across the resistance.

The efficiencies of the 3:1 expansion ratio are affected approximately the same by the several variables. All the efficiencies are considerably lower, however, than the efficiencies of the 2:1 expansion ratio for corresponding conditions.

The effect of the resistance on the diffuser-alone efficiency is partly shown in figures 19 and 20. The results with both the 2:1 and the 3:1 expansion ratios show considerably higher diffuser efficiencies with low values of  $K$  than with high values, as would be expected. The difference, in general, is greater at high angles where the diffuser losses are greater. With the 2:1 expansion ratio the effect on the efficiency of changing  $K$  was much less when the boundary layer was almost zero in thickness. The results with the 3:1 expansion ratio showed considerable effect of changing the resistance under all conditions.

An indication of the improvement in diffuser efficiencies due to the presence of a resistance can be obtained by comparing the present results with those given by Peters (reference 1) and Gibson (reference 2). This comparison is shown in figure 21. Though some difference in the efficiencies may be due to differences in the test conditions, most of it is undoubtedly due to the presence of the resistance at the exit of the diffuser on these tests. It should be pointed out that the initial boundary-layer conditions are unknown for the tests of references 1 and 2, whereas the present efficiencies correspond to the condition of the thickest boundary layer obtained.

In figure 21 an inconsistency may be noted in that the efficiency of the diffuser is lower at high angles for the 2:1 expansion ratio than the 3:1 expansion ratio when the conductivity is 0.2. Unfortunately the accuracy of the curve is poor at extremely low values of  $K$  with an expansion ratio of 2:1. A study of the conversion equation shows that, at low values of  $K$  and  $A_2/A_1$ , any error in the over-all efficiency is multiplied many times in converting it to diffuser efficiency. At higher values of  $A_2/A_1$  and  $K$  the accuracy of the conversion process becomes very good.

#### SUGGESTED METHOD FOR DESIGNING DIFFUSERS IN FRONT OF RESISTANCES IN AIRPLANE DUCTING SYSTEMS

The length of the diffuser is obviously the most important consideration in its design; great care should therefore be exercised in locating the various heat exchangers, compressors, and similar devices so that sufficient diffuser lengths may be obtained to insure efficient

flow. If the various units can be so located that conical diffusers of approximately  $7^\circ$  included angle may be utilized, the system will be about as efficient as possible. (See reference 3.) If the space available does not allow a  $7^\circ$  conical diffuser to expand the air the required amount, as is usually the case, the following layout procedure is suggested for the case where a resistance follows the diffuser:

(a) Lay out a  $7^\circ$  or  $8^\circ$  conic diffuser, starting from the duct entrance. (See fig. 22.)

(b) Lay out a cone of, say,  $20^\circ$  using the resistance as the base and projecting the elements back until they intersect the  $7^\circ$  or  $8^\circ$  entrance cone.

(c) Check ratio of duct area at resistance to that at intersection of  $7^\circ$  and  $20^\circ$  cones. If this expansion ratio is less than 3, the diffuser is within the scope of these tests and is considered to be satisfactory. Draw in diffuser in detail, according to figures 14 and 15. The value of  $l/d$  used should correspond to the thickest boundary layer encountered at any point at the entrance of the diffuser. Thus, a diffuser close to the entrance of a wing duct could use a low value of  $l/d$ . On the other hand, a diffuser close to the entrance of an under-slung fuselage duct would usually require a high value of  $l/d$  because of the thick boundary layer present at the side next to the fuselage.

A certain amount of latitude may be exercised in the design details to suit the case in question. For instance, most duct passages in actual installations will not be circular in cross section. Although a great deal is not known about the behavior of diffusers other than those with circular cross sections, it seems reasonable that the rate of expansion should be slightly less for other cross sections especially for rectangular ducts where the air in the corners is actually expanding at a much greater rate than the air along the center of the sides.

A possibility suggested in reference 4 for diffusers located immediately behind an entry in which the entrance velocity is less than free-stream velocity is that of using a high rate of expansion just back of the entrance, thereby taking advantage of the initial divergence of the

streamlines at the entry. When the entrance remains lined up with the direction of the approaching air stream, a high angle of divergence can probably be used with good efficiency by taking advantage of this effect.

### CONCLUSIONS

The results of this investigation indicated that:

1. The presence of a resistance at the exit of a diffuser allowed the expansion to be made much more rapidly for a given expansion energy loss than was possible with a diffuser discharging into a straight exit tube. The diffuser losses were found to remain small for included angles up to  $30^{\circ}$  with conductivities up to 0.6.

2. The velocity distribution over the face of the resistances was found to be nearly uniform for all conditions except for combinations of high expansion angles and low resistances, which corresponded to inefficient diffusers.

3. The conductivity of the resistance had an important effect on the diffuser efficiency; the greater the resistance, the higher was the diffuser efficiency or the greater was the allowable expansion angle for the same losses.

4. The thickness of the entrance boundary layer had a considerable effect on the efficiency. The initial increments of boundary layer caused a rapid decrease in the diffuser efficiency obtained by a given diffuser shape. Further increases had little additional effect.

5. The correct design of the diffuser form for each expansion ratio, diffuser length, entrance boundary-layer condition, and resistance value was necessary to obtain the highest diffuser efficiency.

Langley Memorial Aeronautical Laboratory,  
National Advisory Committee for Aeronautics,  
Langley Field, Va.

## REFERENCES

1. Peters, H.: Conversion of Energy in Cross-Sectional Divergences Under Different Conditions of Inflow. T.M. No. 737, NACA, 1934.
2. Gibson, A. H.: On the Flow of Water through Pipes and Passages Having Converging or Diverging Boundaries. Proc. Roy. Soc., (London) ser. A, vol. 83, no. 563, March 2, 1910, pp. 366-378.
3. Patterson, G. N.: Modern Diffuser Design. Aircraft Engineering, vol. X, no. 115, Sept. 1938, pp. 267-273.
4. Patterson, G. N.: The Design of Aeroplane Ducts. Aircraft Engineering, vol. XI, no. 125, July 1939, pp. 263-268.

TABLE I.- SCREEN SIZES FOR RESISTANCES

Resistance	Number of screens	Mesh of screen (wires/in.)	Wire diameter (in.)	K for Reynolds number of 270,000 based on screen diameter
1	1	32 x 32	0.012	0.568
2	1	55 x 60	.008	.445
a <sub>3</sub>	1	100 x 100	.005	.315
	1	80 x 65	.006	
a <sub>4</sub>	2	200 x 200	.002	.253
a <sub>5</sub>	2	200 x 16	.005	.174
a <sub>6</sub>	1	200 x 200	.002	.163
	2	200 x 16	.005	

<sup>a</sup> Composed of more than one screen; the mesh of alternate layers is rotated 45°.

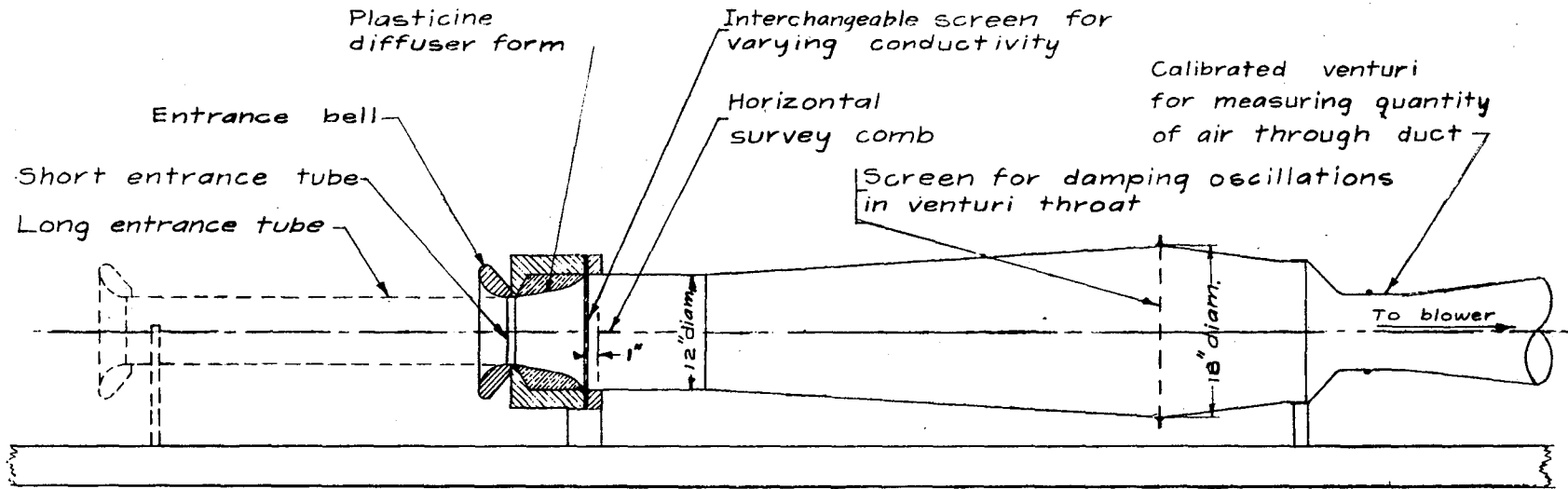

Figure 1. - Arrangement of diffuser test equipment.

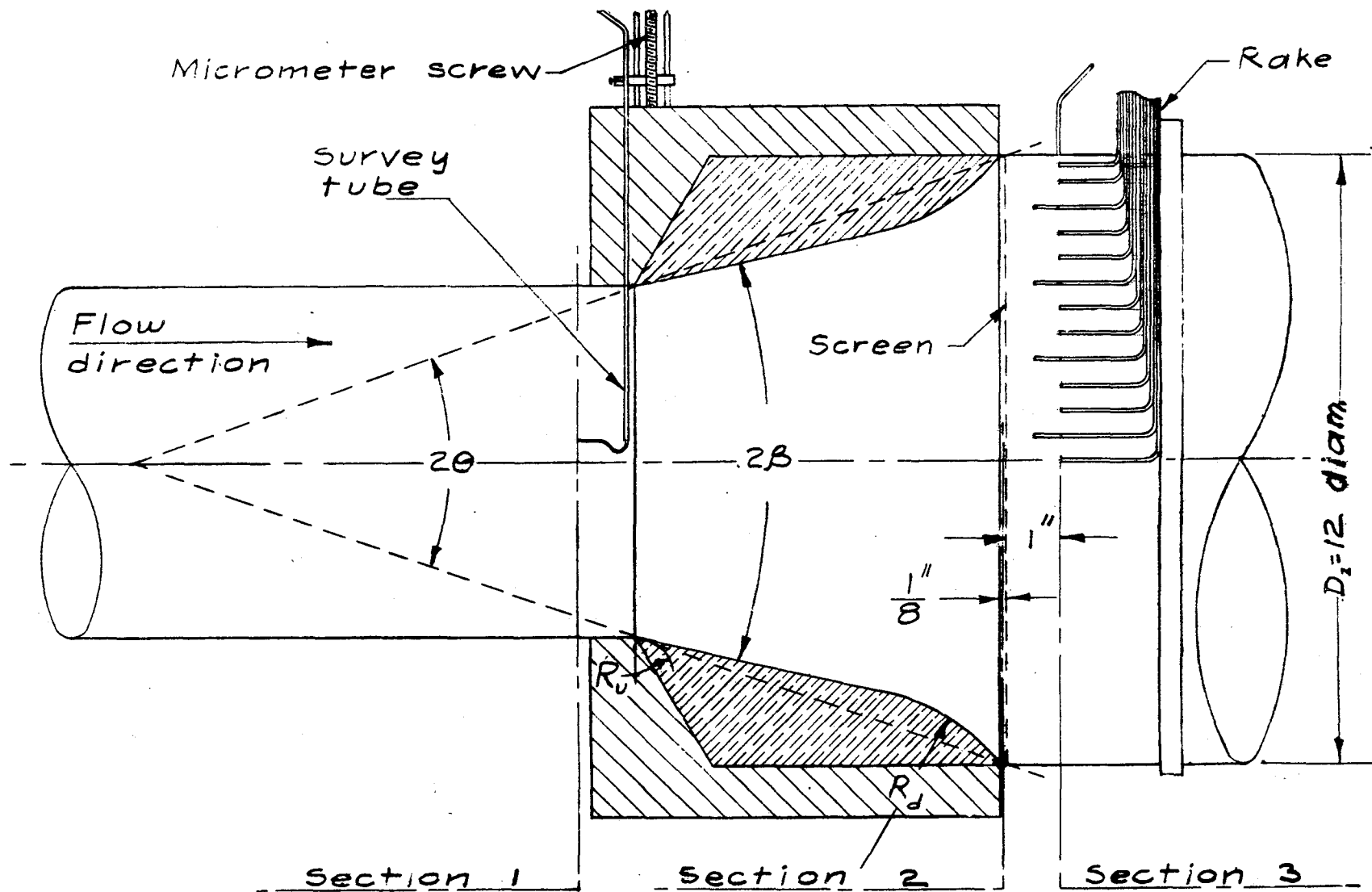

Figure 2.- Diffuser shape and location of survey tubes

Fig. 2

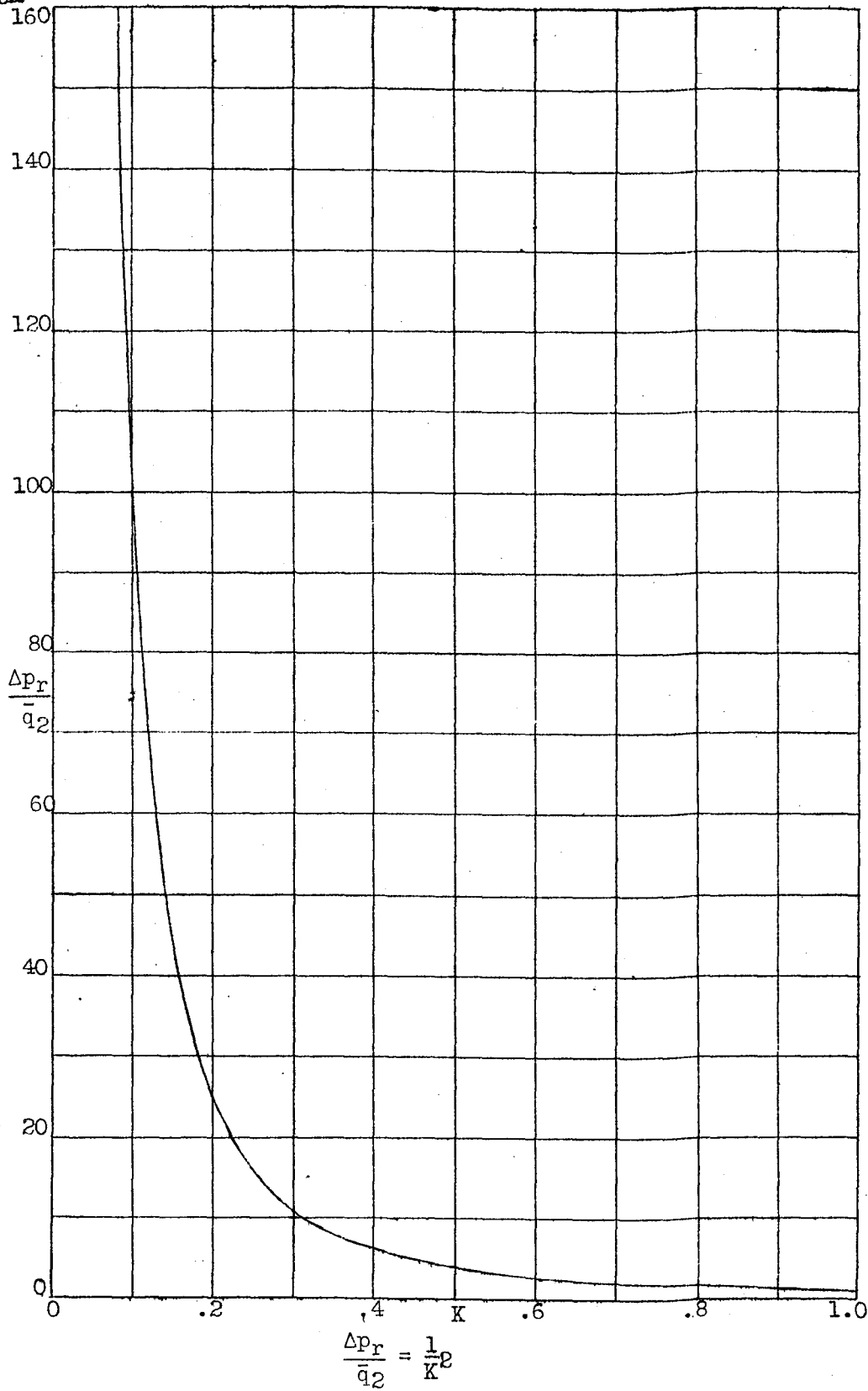

Figure 3.- Relationship between  $\frac{\Delta p_r}{q_2}$  and K.

$$\frac{\Delta p_r}{q_2} = \frac{1}{K} p$$

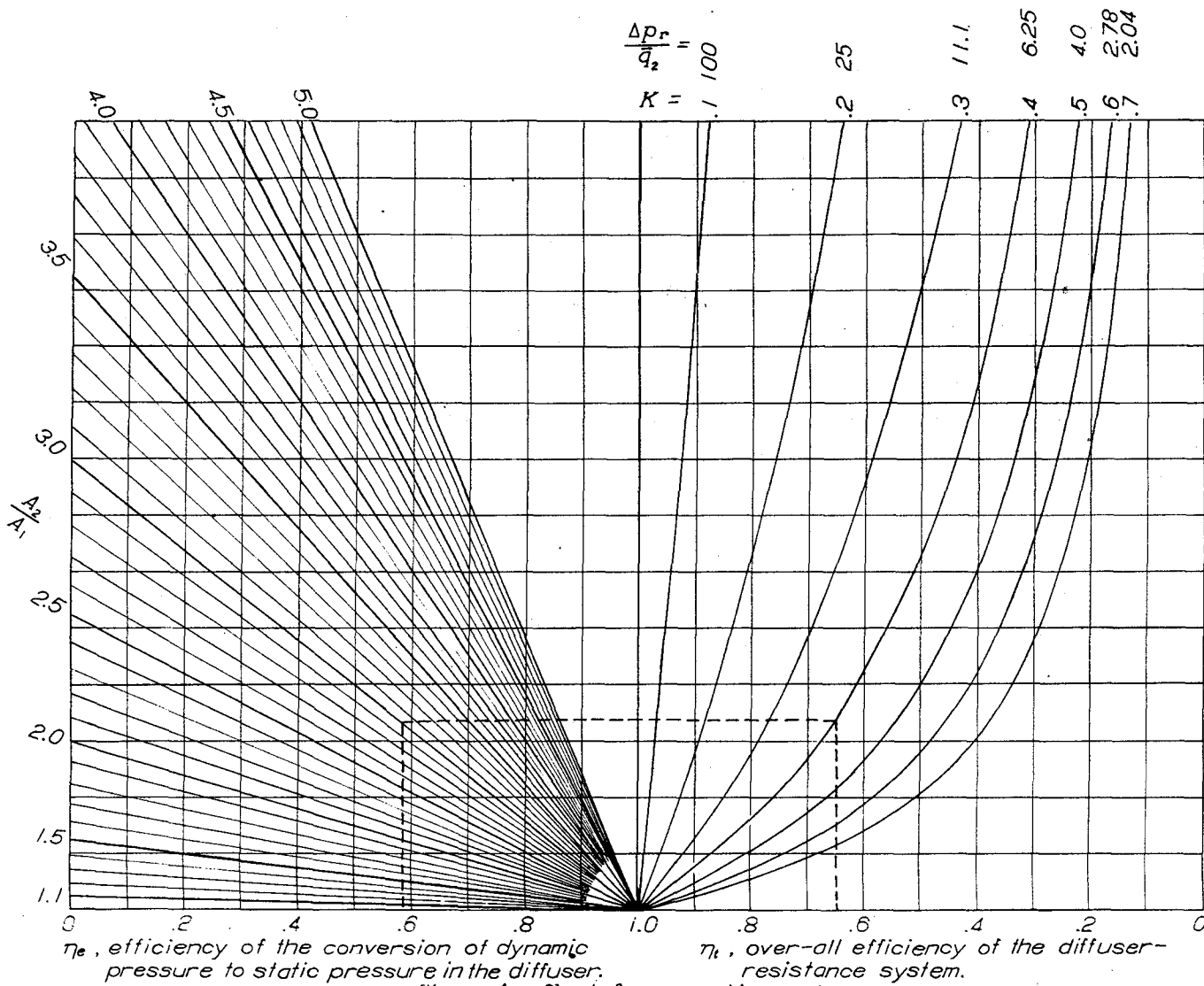
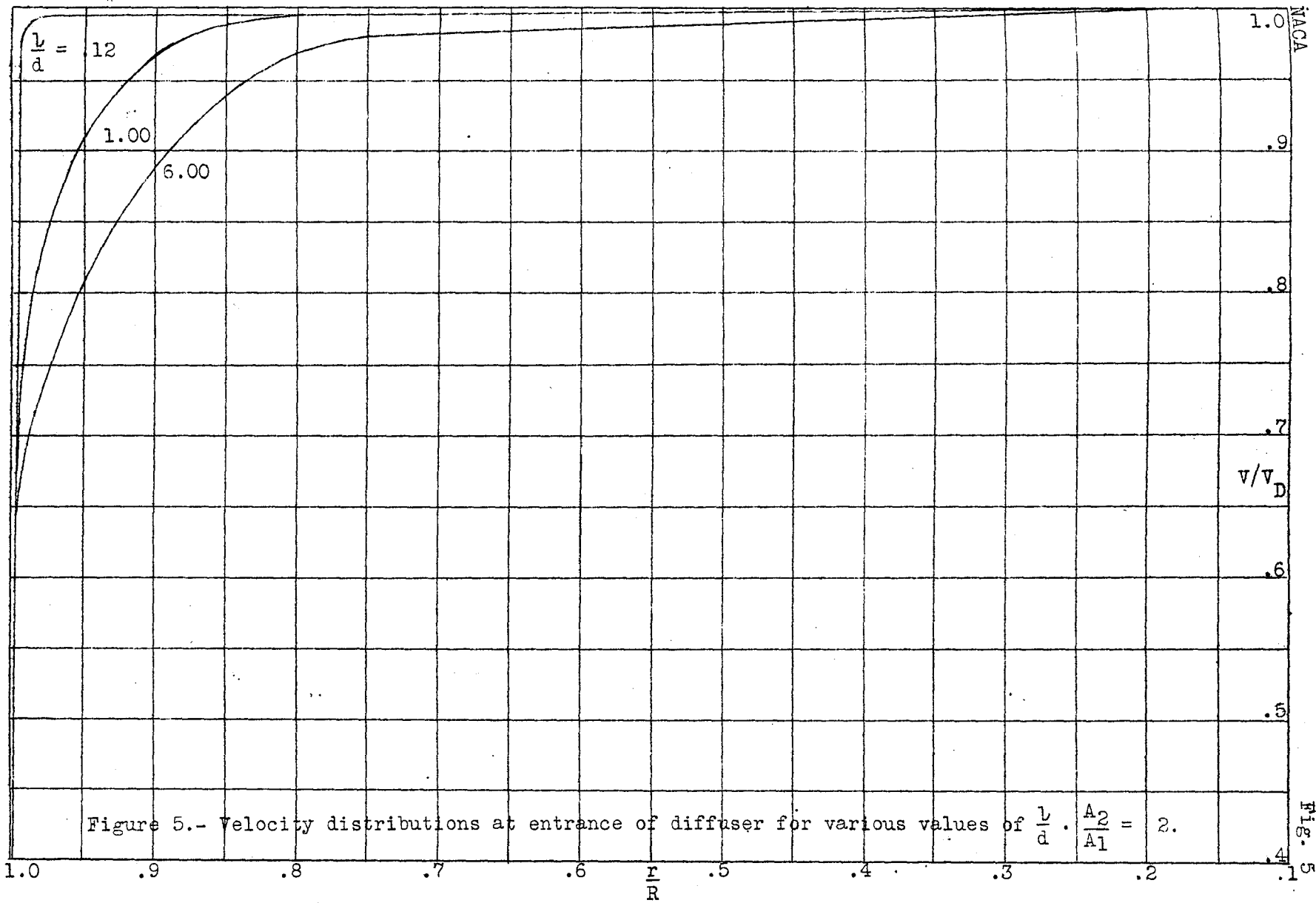

Figure 4.- Chart for converting  $\eta_t$  to  $\eta_e$ .

$$\eta_e = 1 - \frac{1 - \eta_t}{\eta_t K^2 \left[ \left( \frac{A_2}{A_1} \right)^2 - 1 \right]}$$



NACA

FIG. 5

NACA

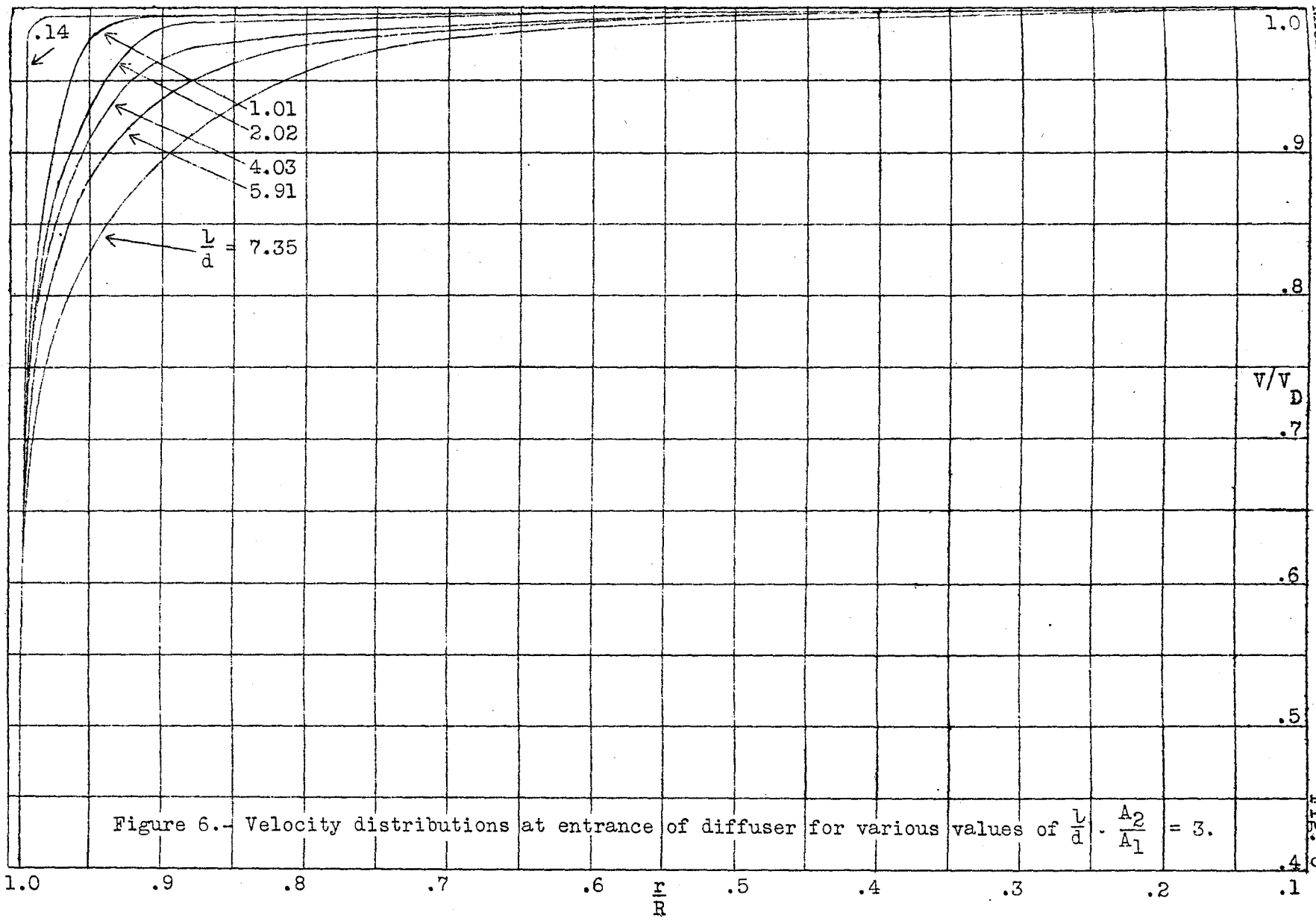

Figure 6.- Velocity distributions at entrance of diffuser for various values of  $\frac{L}{d} \cdot \frac{A_2}{A_1} = 3.$

Fig. 6

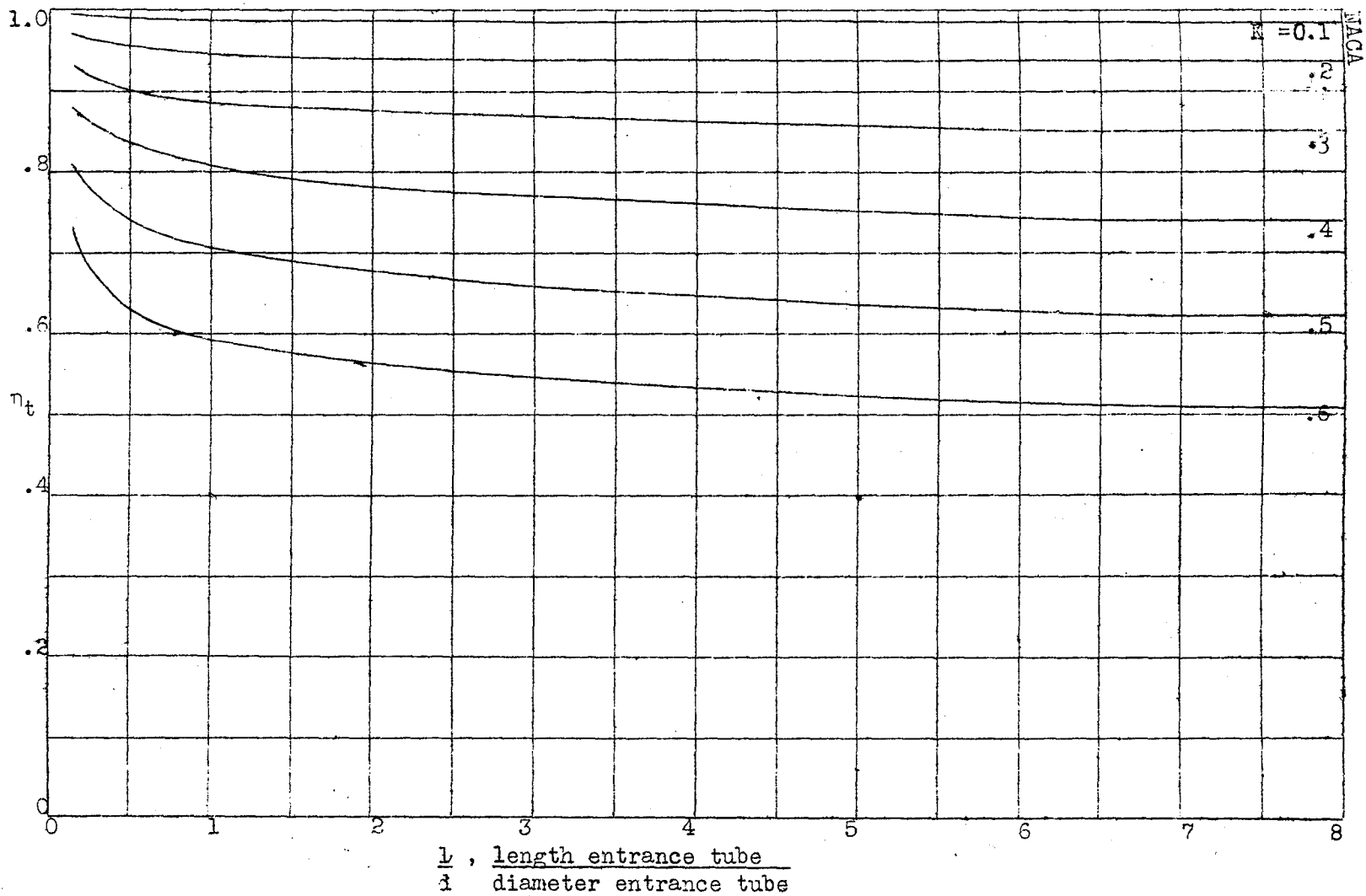

Figure 7.- Variation of  $\eta_t$  with  $\frac{l}{d}$  for various values of  $K$ .  $\frac{A_2}{A_1} = 3$ ;  $2\theta = 24^\circ$ ;  $2\theta = 38.5^\circ$ .

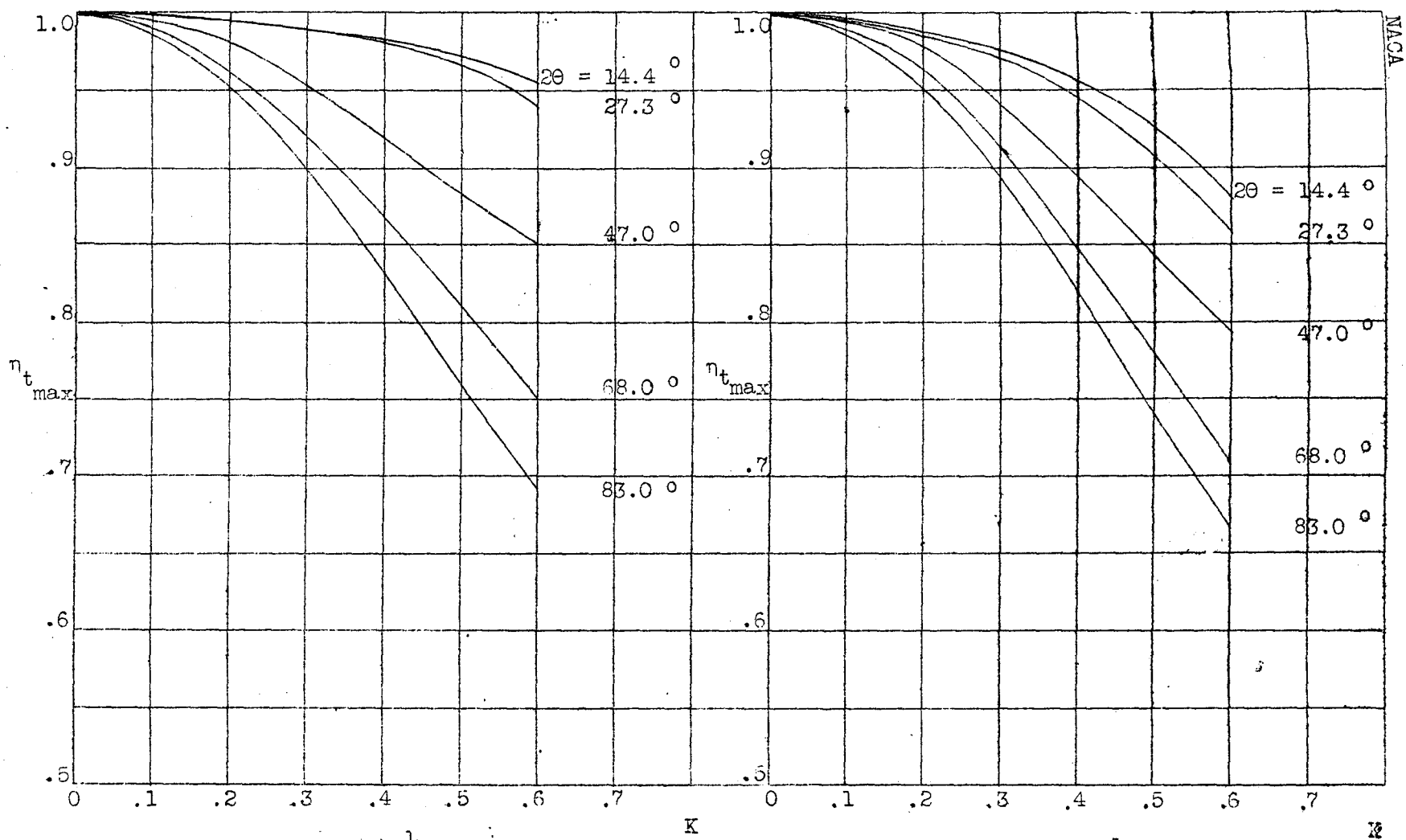

Figure 8.- Variation of  $\eta_{t_{max}}$  with  $K$  for various effective angles.  $\frac{A_2}{A_1} = 2$ .

NACA

Fig. 8

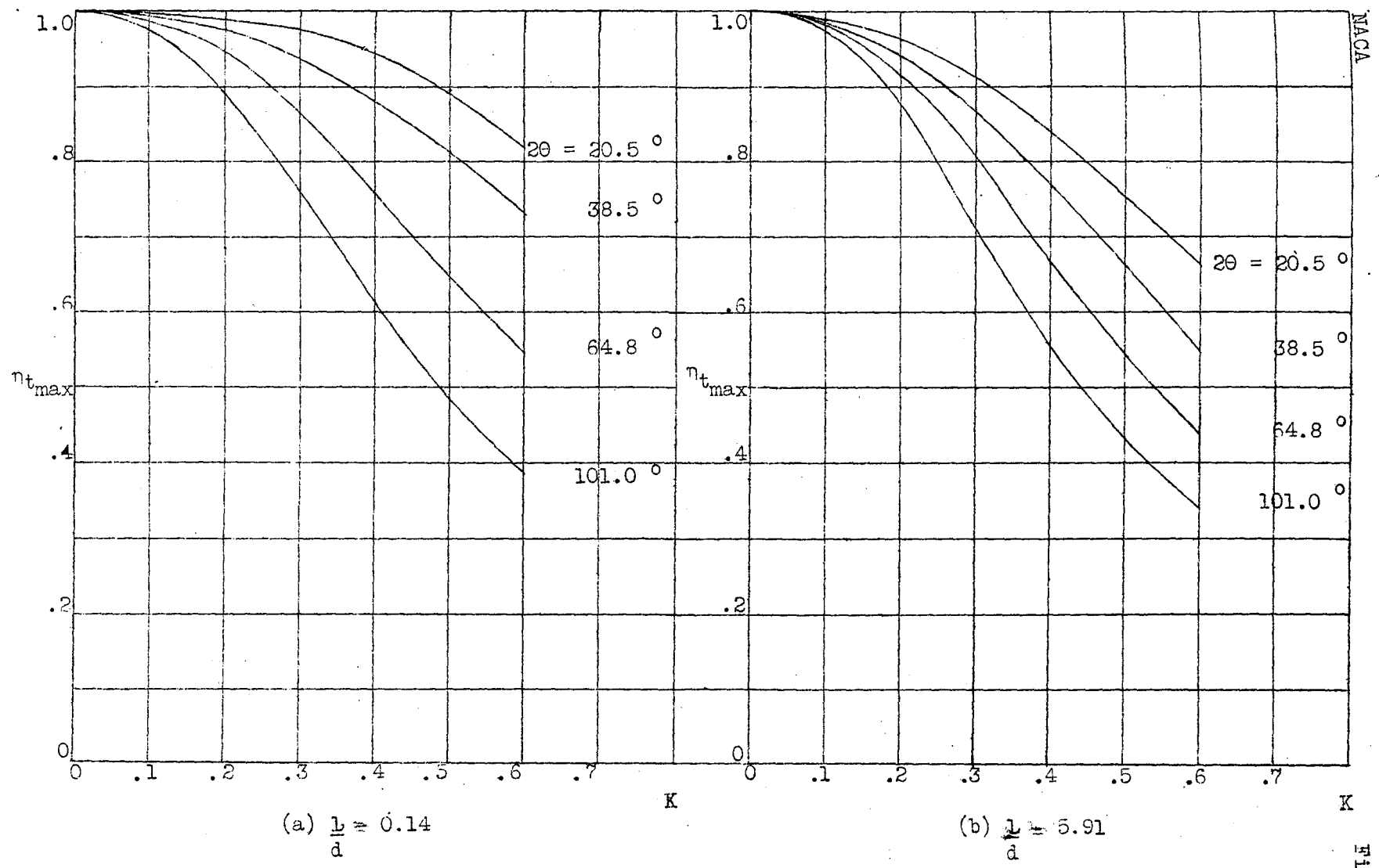

Figure 9.- Variation of  $\eta_{t,max}$  with  $K$  for various effective angles.  $\frac{A_2}{A_1} = 3$ .

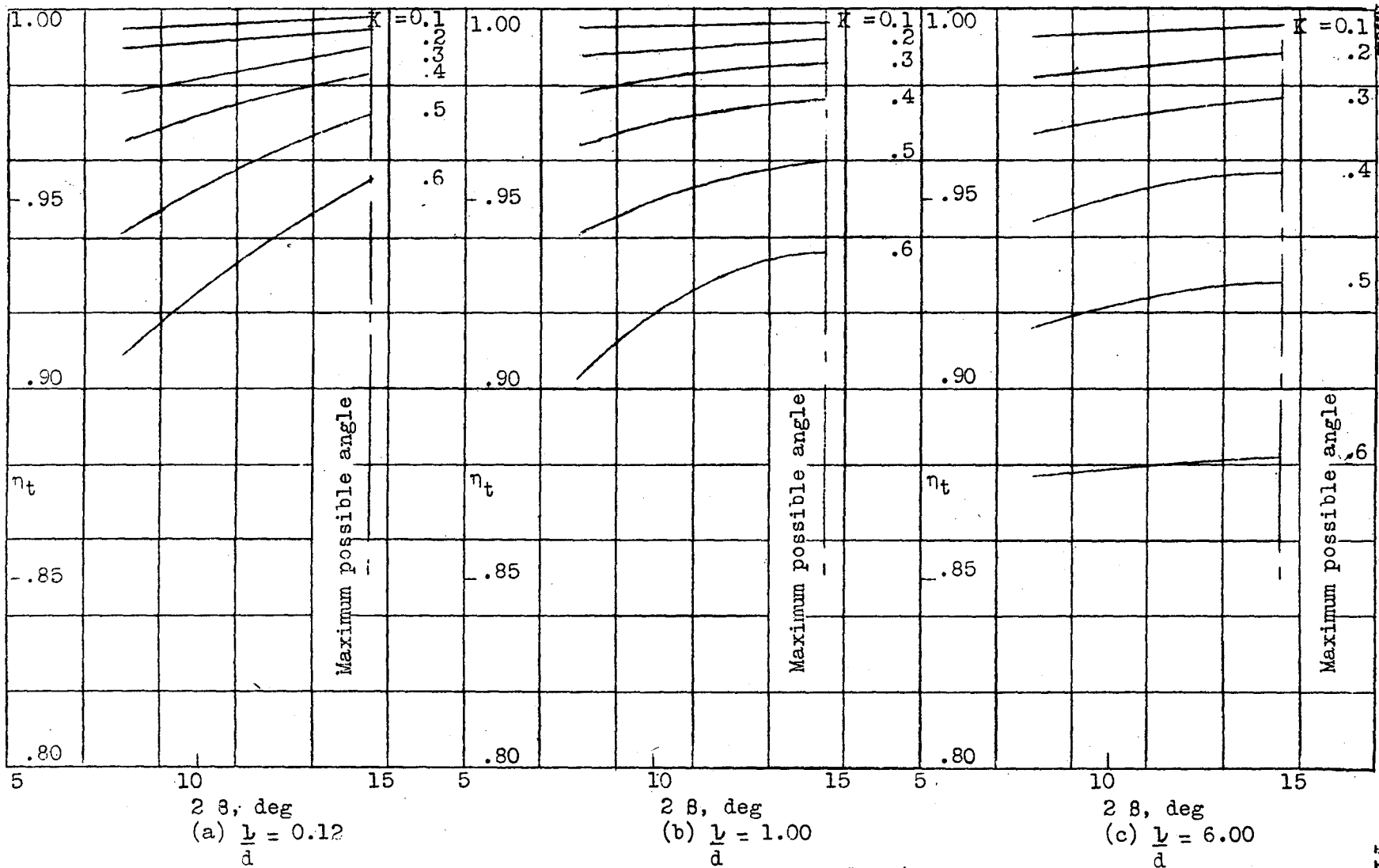

Figure 10.- Variation of  $\eta_t$  with  $2\beta$  for various values of  $K$  and  $\frac{l}{d} \cdot \frac{\Lambda_2}{\Lambda_1} = 2$ ;  $2\theta = 14.4^\circ$ .

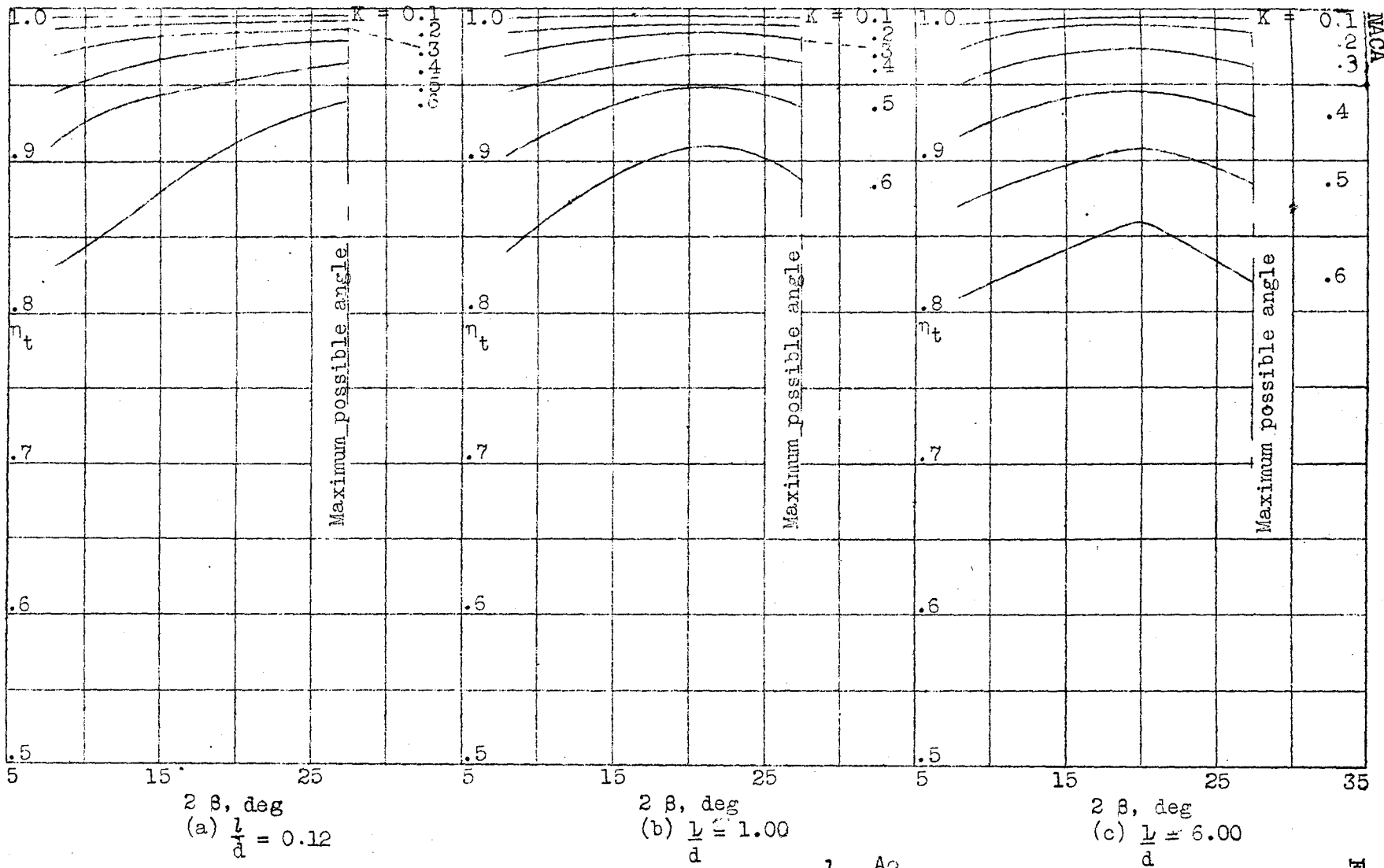

Figure 11.- Variation of  $\eta_t$  with  $2\beta$  for various values of  $K$  and  $\frac{l}{d} \cdot \frac{A_0}{A_1} = 2$ ;  $2\theta = 27.3^\circ$ .

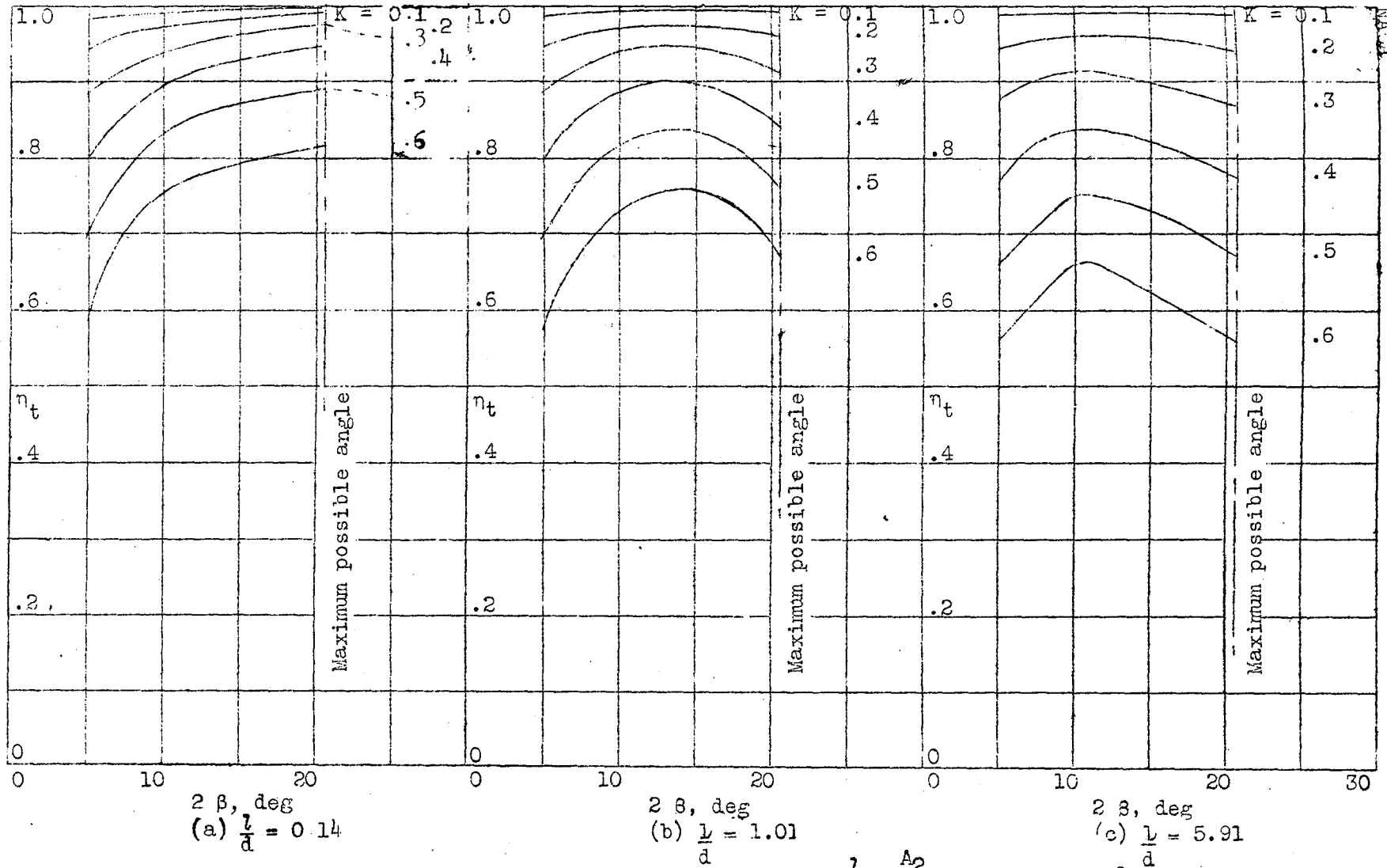

Figure 12.- Variation of  $\eta_t$  with  $2\beta$  for various values of  $K$  and  $\frac{l}{d}$ .  $\frac{A_2}{A_1} = 3$ ;  $2\theta = 20.5^\circ$ .

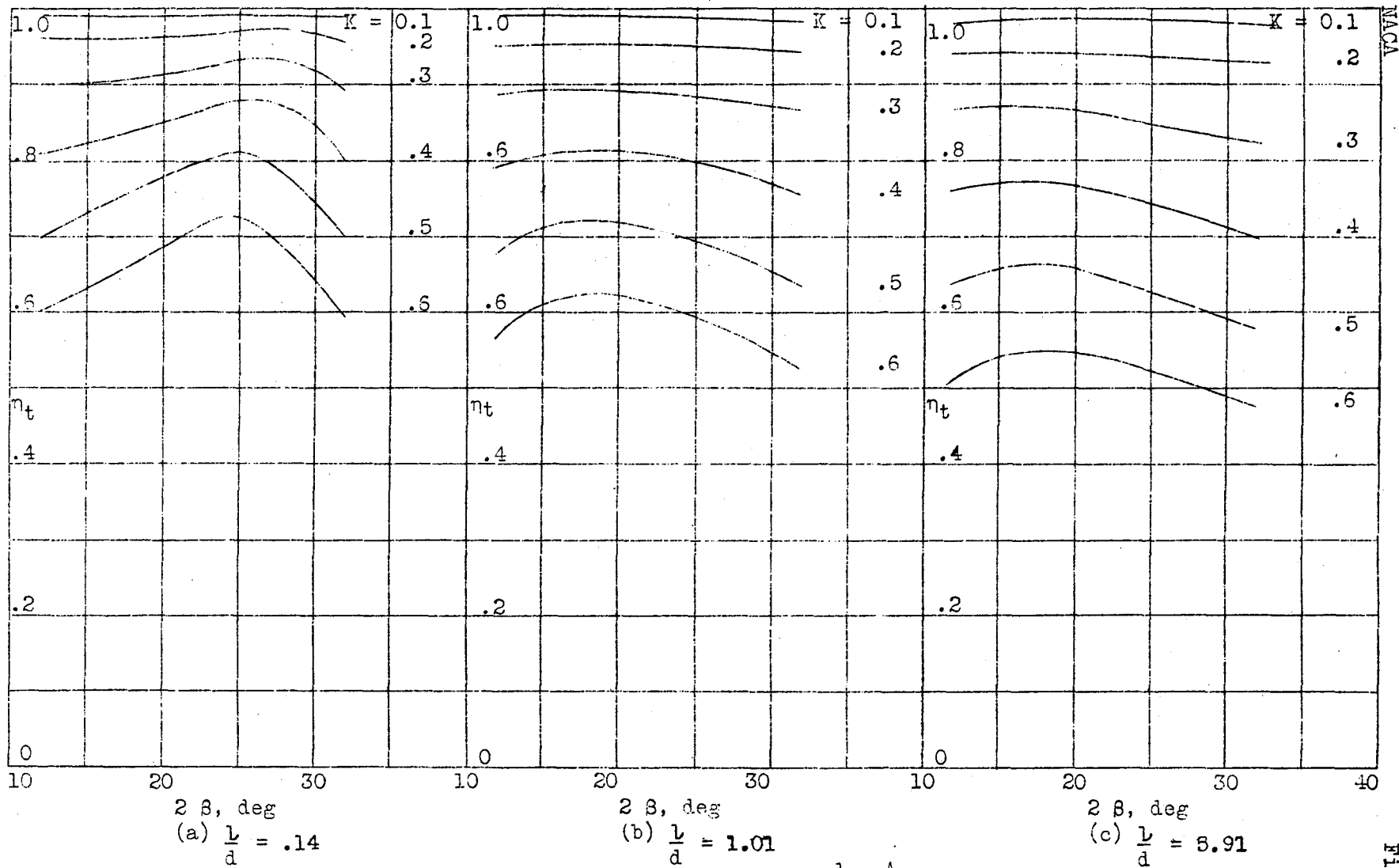
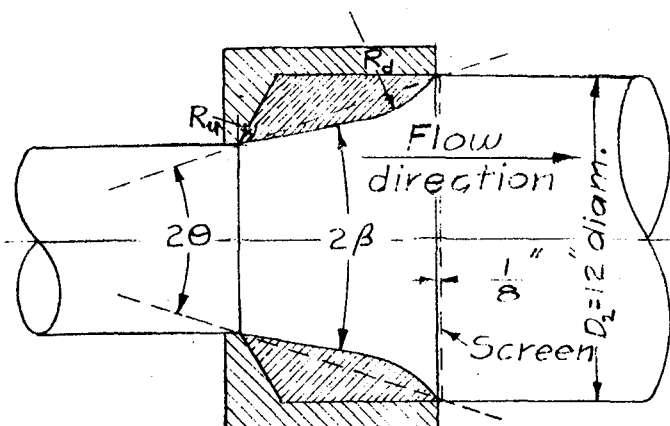

Figure 13.- Variation of  $\eta_t$  with  $2\beta$  for various values of  $K$  and  $\frac{l}{d} \cdot \frac{A_2}{A_1} = 3$ ;  $2\theta = 38.5^\circ$ .

NACA

Fig. 13



$R_2 = .333 D_2$  } except where  
 $R_1 = .0625 D_2$  } otherwise noted  
 -----  
 unverified portions  
 of curve -----

K	Symbol
.2	○
.4	□
.6	△

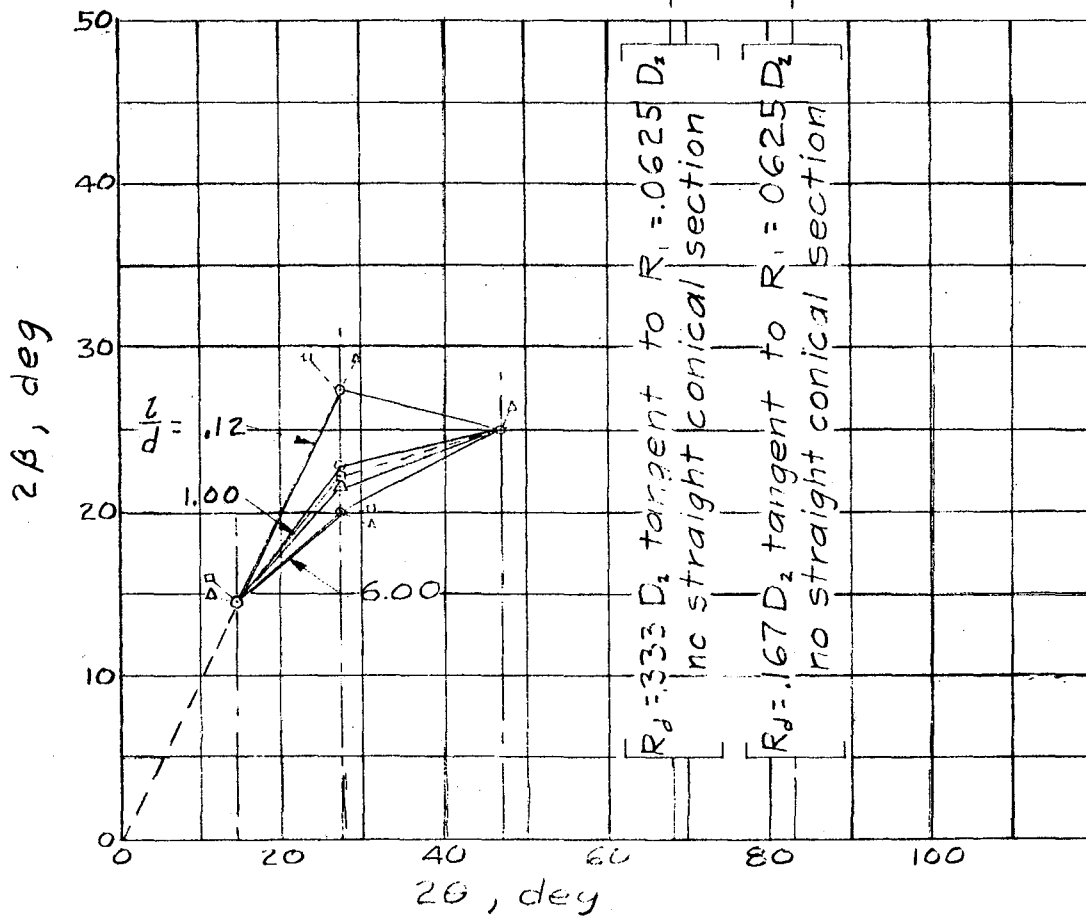
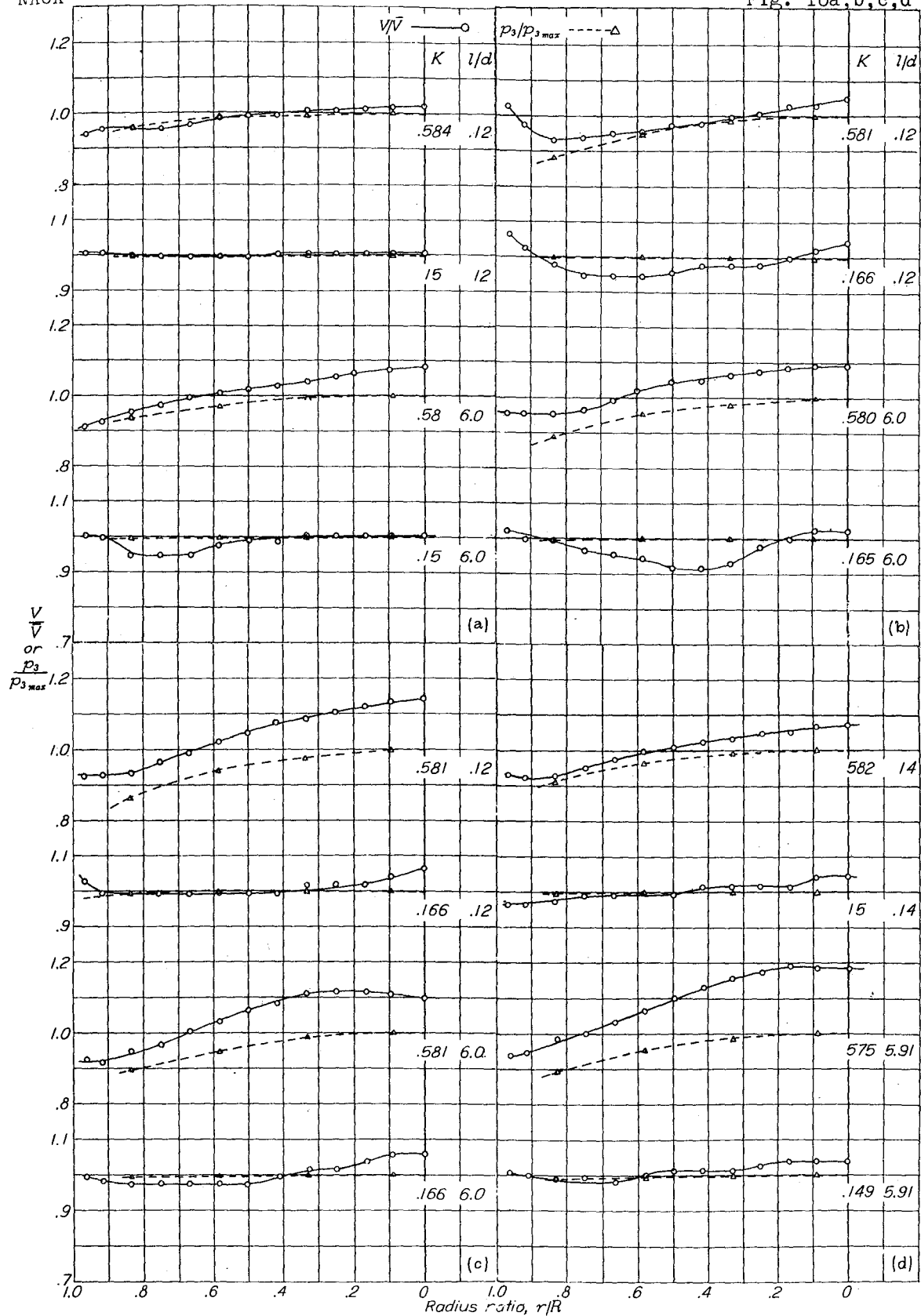

Figure 14-Diffuser forms for  $\eta_{t_{max}}$  at various values of  $2\theta$ .  $\frac{A_2}{A_1} = 2$ .





(a)  $A_2/A_1=2$ ;  $2\theta=14.4^\circ$ ;  $2\beta=14.5^\circ$

(b)  $A_2/A_1=2$ ;  $2\theta=47^\circ$ ;  $2\beta=25^\circ$

(c)  $A_2/A_1=2$ ;  $2\theta=83^\circ$

(d)  $A_2/A_1=3$ ;  $2\theta=20.5^\circ$ ;  $2\beta=16^\circ$

Figure 16 (a to e).- Velocity and static-pressure distributions behind the resistance for various values of  $l/d$  and  $K$ .

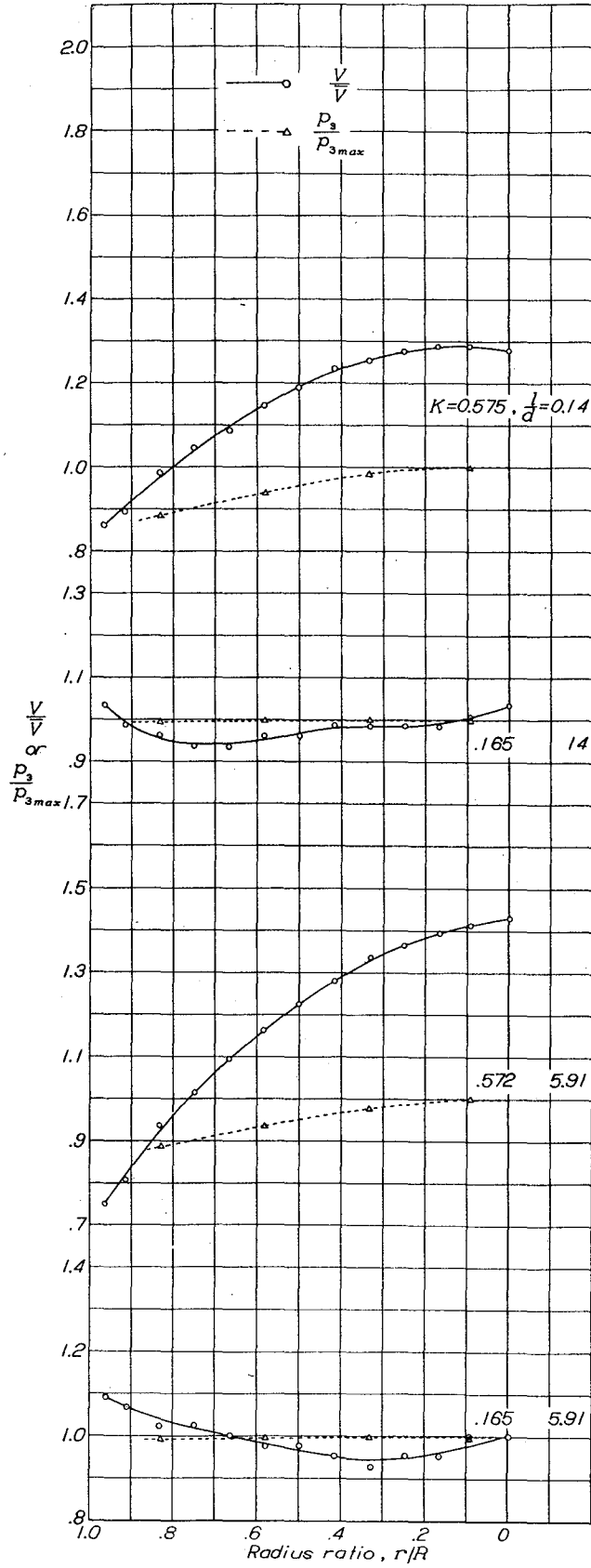

(e)  $\frac{A_2}{A_1} = 3;$   
 $2\theta = 64.8^\circ;$   
 $2\beta = 25^\circ.$

Figure 16e.

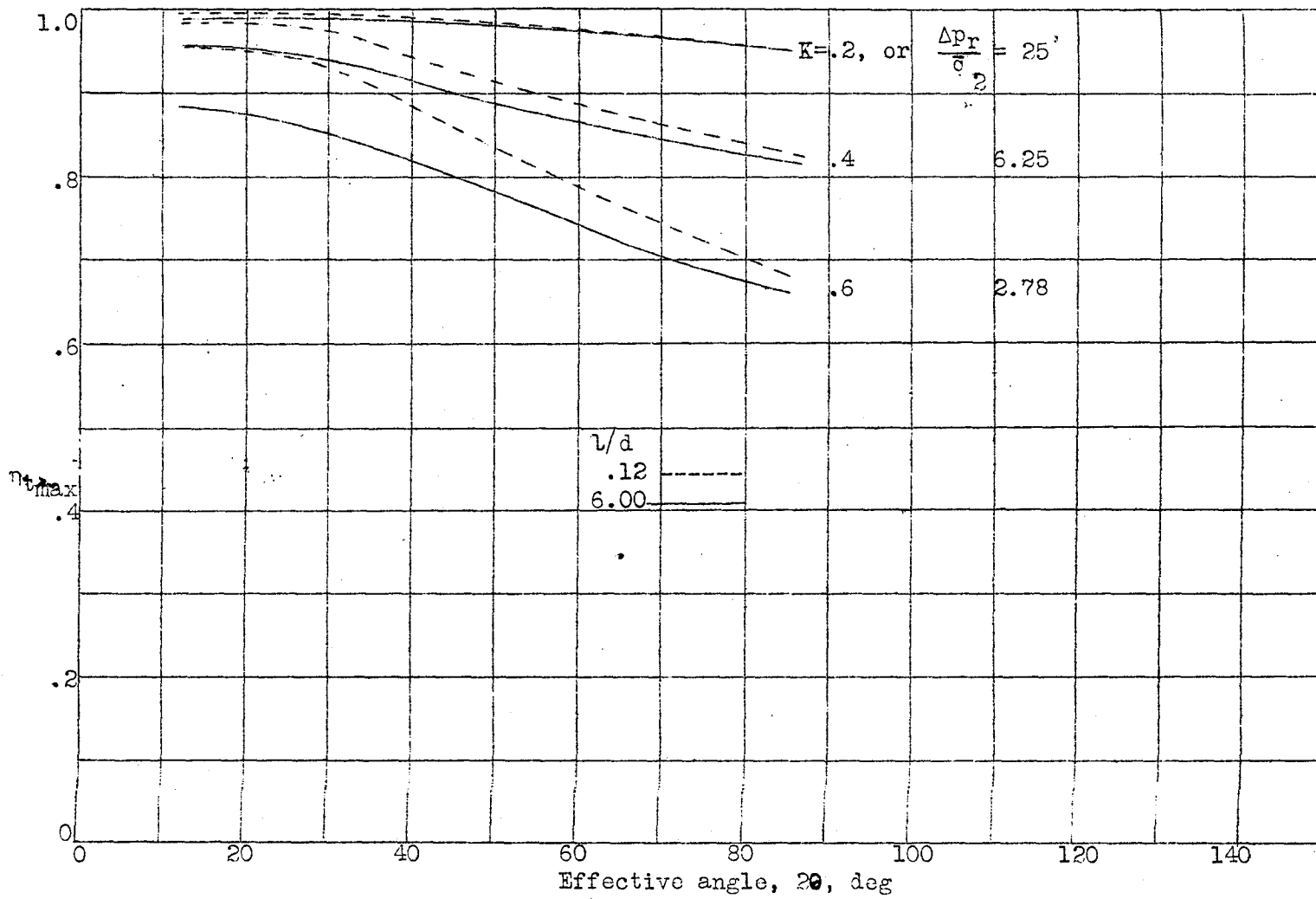

Figure 17.- Maximum over-all diffuser-resistance efficiencies for various values of  $K$  and  $\frac{l}{d} \cdot \frac{A_2}{A_1} = 2.4$

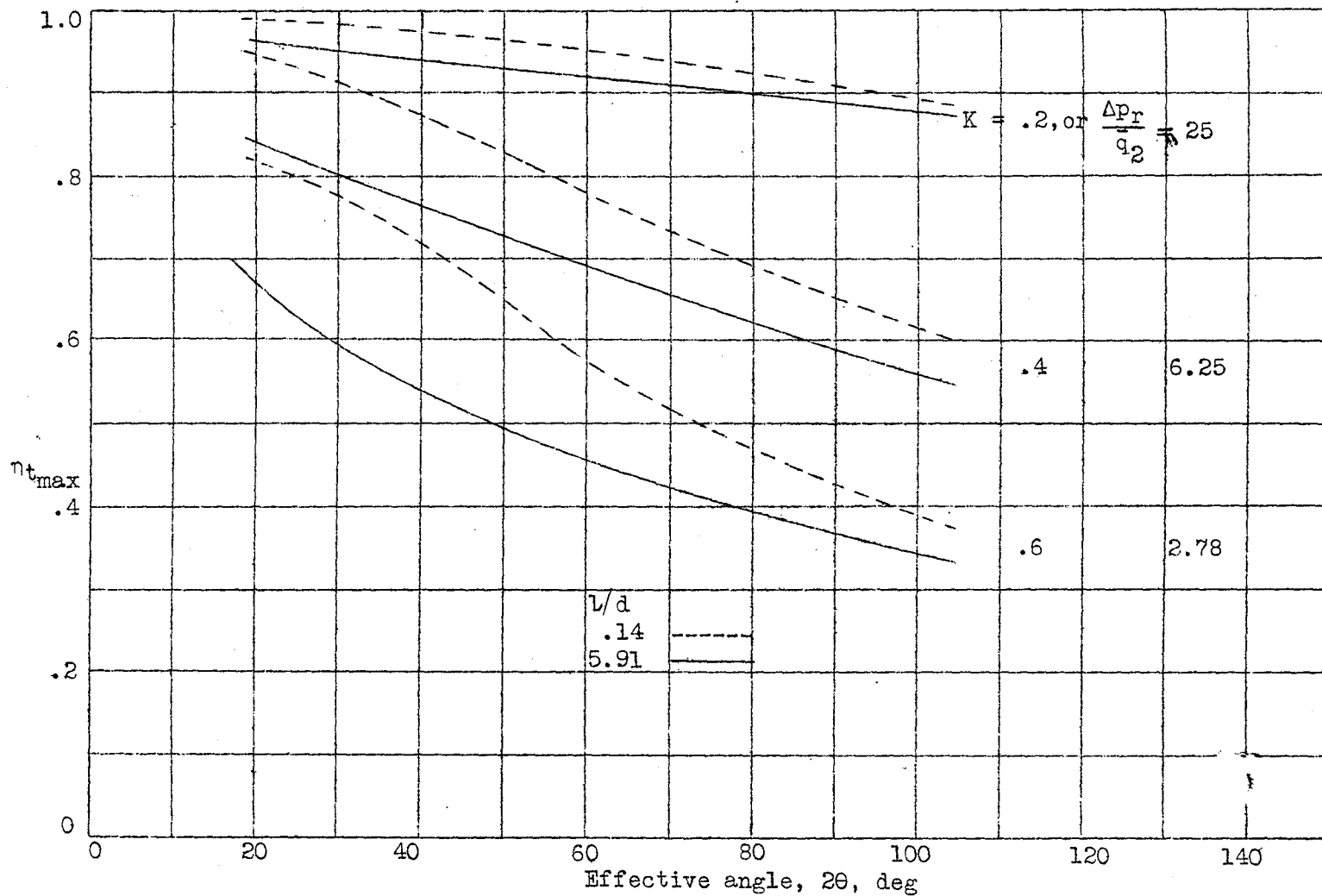
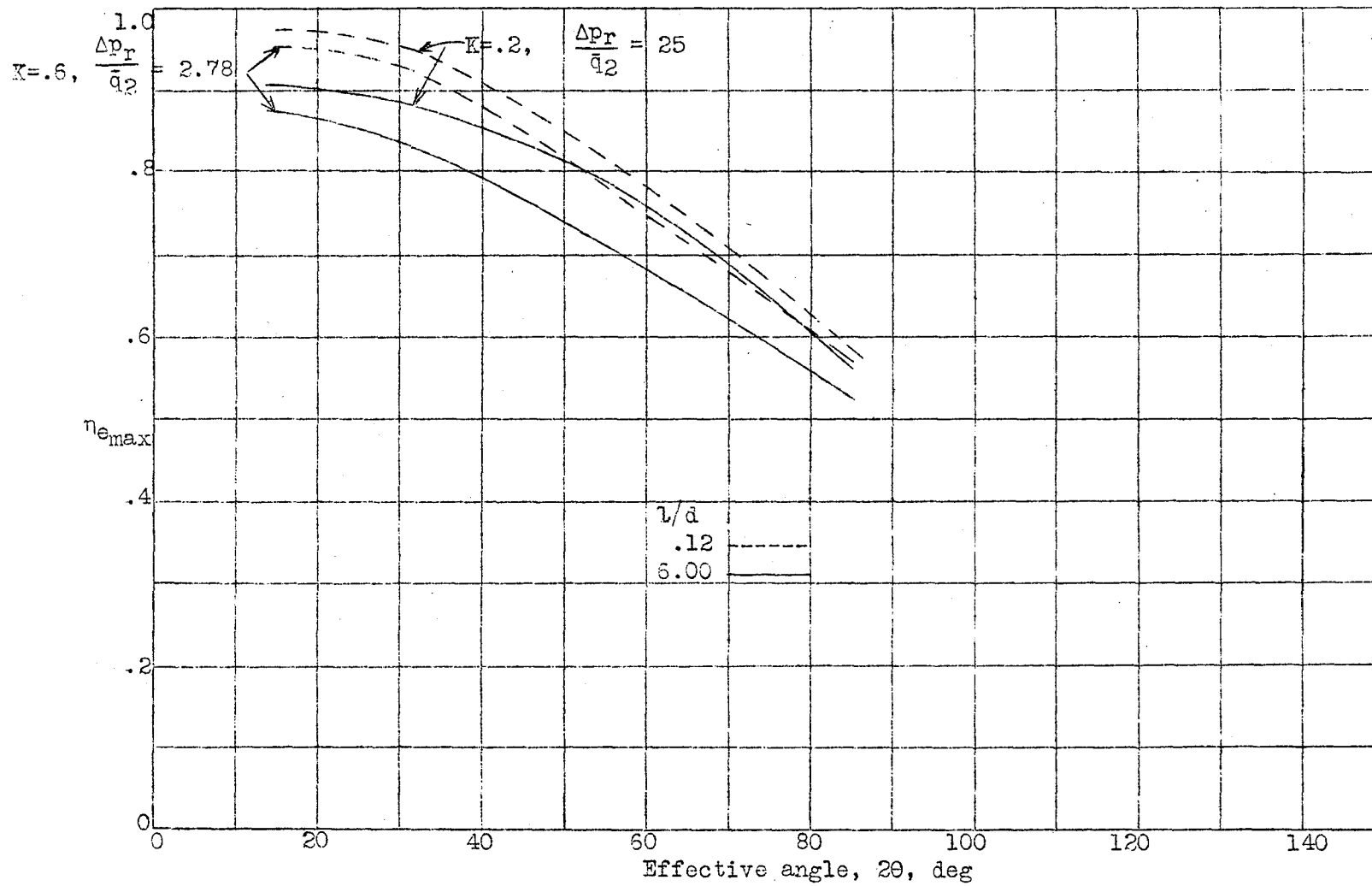

Figure 18.- Maximum over-all diffuser-resistance efficiencies for various values of  $K$  and  $\frac{l}{d} \cdot \frac{A_2}{A_1} = 3$ .



NACA

Figure 19.- Maximum diffuser efficiencies for various values of  $K$  and  $\frac{t}{d} \cdot \frac{A_2}{A_1} = 2$ .

FIG. 19

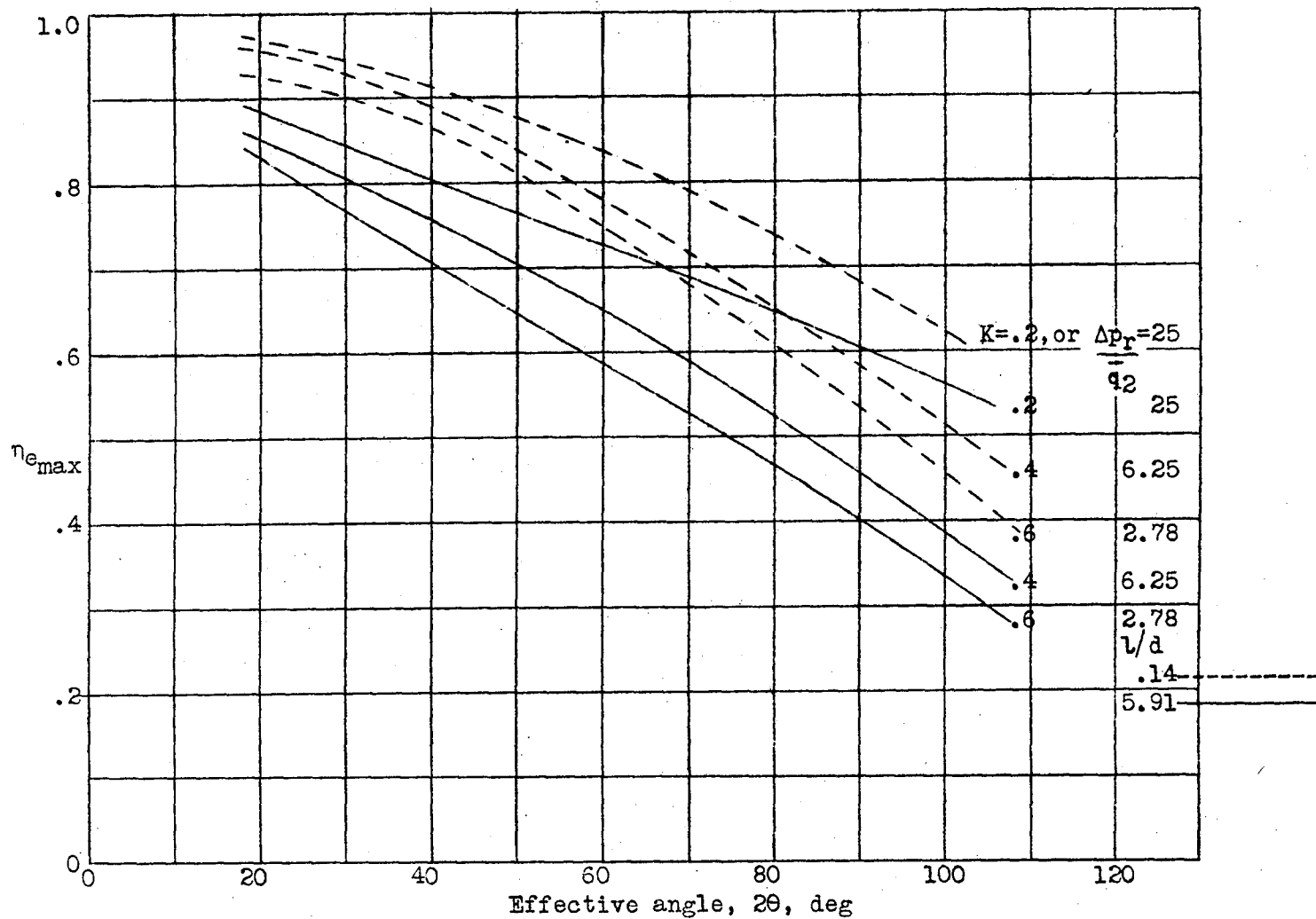

Figure 20.- Maximum diffuser efficiencies for various values of K and  $\frac{l}{d} \cdot \frac{A_2}{A_1} = 3$ .

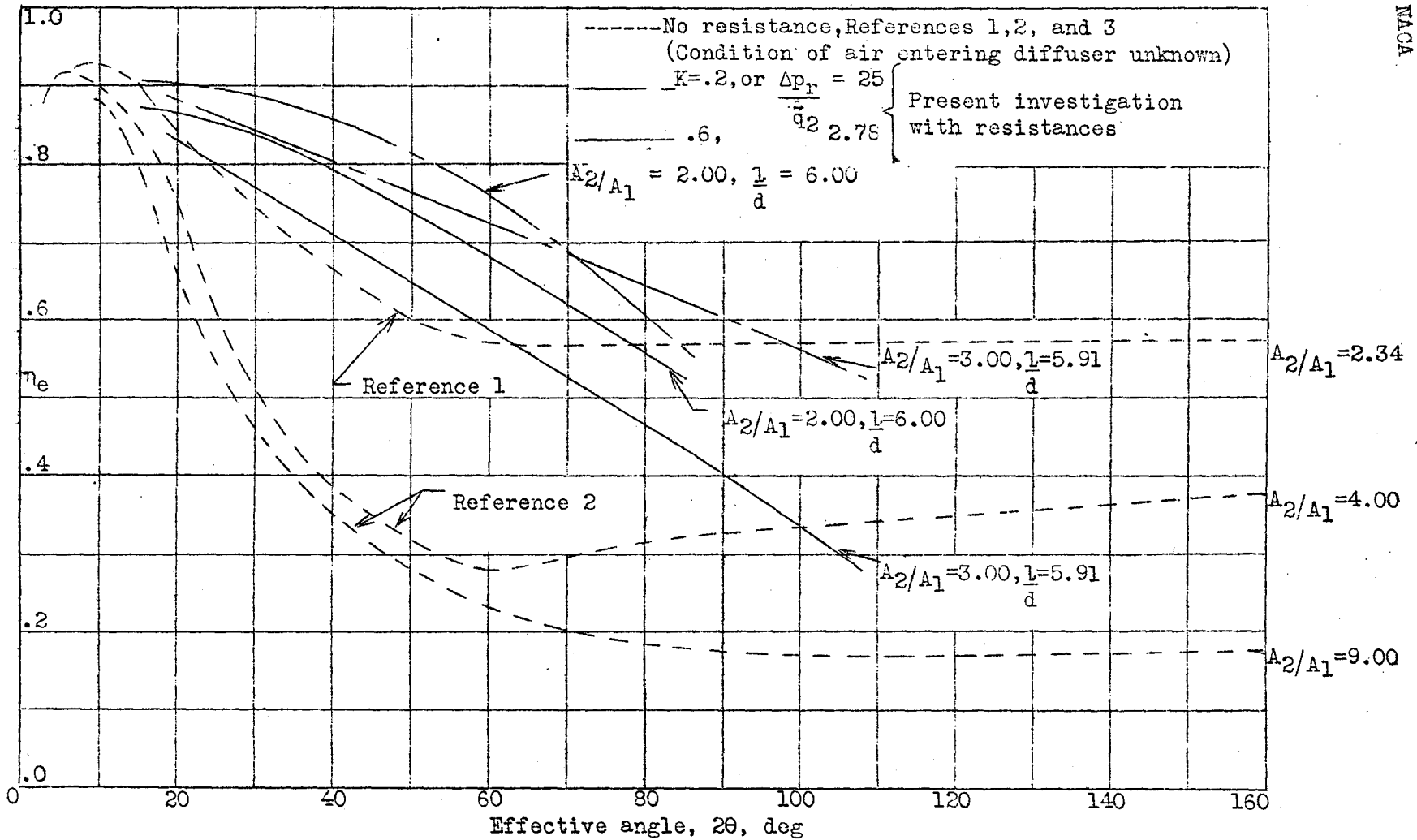

Figure 21.- Comparison of diffuser efficiencies with and without resistance, circular sections.

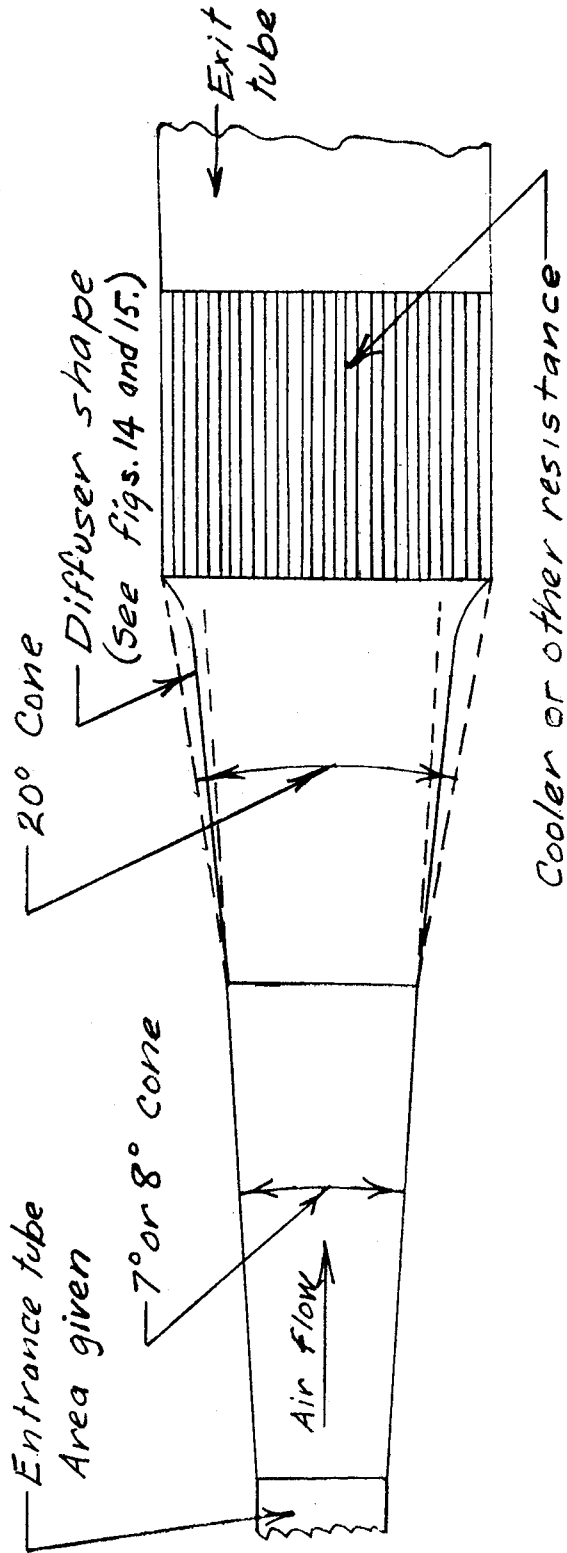

Figure 22. - Suggested diffuser design.

**TITLE:** An Investigation of Diffuser-Resistance Combinations in Duct Systems

ATI- 7385

**AUTHOR(S):** McLellan, C.; Nichols, M. R.

REVISION

(None)

**ORIGINATING AGENCY:** National Advisory Committee for Aeronautics, Washington, D. C.

ORIG. AGENCY NO.

ARR-L-329

**PUBLISHED BY:** (Same)

PUBLISHING AGENCY NO.

DATE	DOC. CLASS.	COUNTRY	LANGUAGE	PAGES	ILLUSTRATIONS
Feb '42	Unclass.	U.S.	Eng.	37	tables, graphs, drwgs

**ABSTRACT:**

Ducts in which air is expanded in front of diffuser resistances are investigated. For expansion ratios of 2:1 and 3:1, the magnitudes of resistance and boundary layer present at entrance of diffuser were varied for a series of diffuser shapes. Effects on diffuser-resistance efficiencies, diffuser efficiencies, and velocity distributions were studied. Good diffuser shapes were determined for a wide range of conditions. Greater resistance allows a higher expansion rate. Entrance boundary layer had large effect.

**DISTRIBUTION:** Request copies of this report only from Originating Agency

**DIVISION:** Aerodynamics (2)  
**SECTION:** Boundary Layer (5)

**SUBJECT HEADINGS:** Boundary layer (18200); Diffusers (30200); Flow through ducts (41200)

**ATI SHEET NO.:** R-2-5-8

Air Documents Division, Intelligence Department  
Air Materiel Command

AIR TECHNICAL INDEX

Wright-Patterson Air Force Base  
Dayton, Ohio