

*Revision Copy*

NATIONAL ADVISORY COMMITTEE FOR AERONAUTICS

# WARTIME REPORT

ORIGINALLY ISSUED  
March 1945 as  
Advance Restricted Report L5C01a

ON THE SHEAR STRENGTH OF SKIN-STIFFENER PANELS

WITH INSPECTION CUT-OUTS

By Paul Kuhn and Simon H. Diskin

Langley Memorial Aeronautical Laboratory  
Langley Field, Va.

# NACA

WASHINGTON

NACA WARTIME REPORTS are reprints of papers originally issued to provide rapid distribution of advance research results to an authorized group requiring them for the war effort. They were previously held under a security status but are now unclassified. Some of these reports were not technically edited. All have been reproduced without change in order to expedite general distribution.

NACA ARR No. L5C01a

## NATIONAL ADVISORY COMMITTEE FOR AERONAUTICS

## ADVANCE RESTRICTED REPORT

## ON THE SHEAR STRENGTH OF SKIN-STIFFENER PANELS

## WITH INSPECTION CUT-OUTS

By Paul Kuhn and Simon H. Diskin

## SUMMARY

Strength tests and strain measurements were made of 19 long shear panels with rectangular inspection cut-outs; that is, cut-outs obtained by removing the sheet between two adjacent stringers without cutting any stringer. The test results indicated that the stress concentration existing at low stresses tends to disappear at very high stresses and that the assumption of uniform stress distribution leads to a satisfactory correlation of the test results. Stiffening of the sheet bay containing the cut-out was found to have practically no effect on the panel strength. Reinforcing the bay containing the cut-out by means of doubler plates raised the strength of the panel, but the efficiency of the doubler plates varied widely and was low in all cases.

## INTRODUCTION

The simplest type of cut-out in a stiffened shell is the type in which the skin between two adjacent stringers is removed for some distance along the stringers to form a rectangular opening. The only type of loading of importance for such cut-outs is that producing shear, because normal stresses in the plane of the panel are absorbed mainly by the stringer-rib system. The shear stress carried by the critical sheet bay (the bay containing the cut-out) theoretically reaches its maximum at the end of the cut-out and decreases rapidly with increasing distance from the cut-out. If suitable simplifying assumptions are made, the stress concentration caused by the cut-out may be calculated by a simple formula derived from the shear-lag theory (reference 1), which has been verified experimentally (reference 2) in the elastic range for

sheet not subjected to shear buckling. At the high stresses encountered just before the ultimate load is reached, buckling as well as yielding usually occurs in the sheet. Under these conditions, the formula requires modification that must be based on additional simplifying assumptions if the analysis is to remain simple. For these and other reasons (see reference 1), the accuracy of the modified theory as applied to the calculation of the ultimate load is doubtful, and the exploratory tests of reference 1 were too limited in scope to allow definite conclusions to be made.

The present investigation was undertaken in order to obtain additional information on the problem of how to calculate the ultimate strength and, incidentally, to obtain some preliminary conclusions on the effectiveness of various types of reinforcements.

#### TEST SPECIMENS AND TEST PROCEDURE

Cut-out panels.- Tests were made in the Langley Structures Research Laboratory of 19 skin-stiffener panels with cut-outs. Two basic types of test panel were used. (See fig. 1.) Each panel consisted of a long narrow sheet of 24S-T aluminum alloy with a rectangular cut-out in the center. The cut-out was bounded by longitudinal stringers of either steel or 24S-T aluminum alloy. (See table 1.) Transverse ribs also were provided to furnish the transverse reactions necessary to permit the development of diagonal tension. Panels of type 1 were slightly longer than those of type 2 and had stringers as well as transverse ribs on both sides of the sheet; panels of type 2 had stringers on one side and ribs on the other side. Detailed dimensions of the individual panels are given in table 1. The net cross-sectional area listed in this table is the product of sheet thickness and length of net section, which was taken as panel length minus cut-out length minus the sum of the diameters of the rivet holes along the stringer.

Additions made to the basic panels in attempts to increase the strength were of two types. The first type merely stiffened the critical sheet bay either by very closely spaced transverse angles (fig. 2(a)), by a stiffener plate (fig. 2(b)), or by an auxiliary stringer (fig. 2(c)). The second type reinforced the critical

bay either by small individual doubler plates (fig. 2(d)) or by a large doubler plate surrounding the cut-out (fig. 2(e)). It should be noted that the stiffener plate indicated in figure 2(b) did not extend beneath the stringers, whereas the doubler plate indicated in figure 2(d) did.

The stringers were attached with  $\frac{1}{8}$ -inch rivets pitched  $\frac{3}{4}$  inch. On the panels with short cut-outs or without cut-out (panels 7, 8, and 9), doubler plates were used over the edge sheet bays to ensure that failure would take place along the stringer rather than along the edge of the panel. The panels were riveted with  $\frac{3}{16}$ -inch rivets pitched  $\frac{3}{4}$  inch along one long edge to a fixture attached to a rigid abutment. The other long edge was riveted to a heavy loading bar. A longitudinal load applied to the loading bar produced essentially pure shear in the test panel. The load was applied by means of a hydraulic jack accurate to better than 1 percent. Thickness measurements on the sheet were accurate to about 0.0002 inch.

Electric strain gages (Baldwin-Southwark SR-4) were applied to specimens 5 to 11 and to specimen 16 in order to obtain some information about the uniformity of the lengthwise strain distribution. The gages were applied in pairs on opposite sides of the sheet. The axes of the gages were at  $45^\circ$  to the axes of the specimens and were approximately parallel to the diagonal-tension folds. No attempt was made to measure shear stresses by means of rosettes because tests have demonstrated that it is impossible at present to evaluate with sufficient accuracy strain readings taken across severe buckles such as diagonal-tension folds.

Coupon tests.— The ultimate tensile strengths of the sheets were obtained by tests on standard tensile coupons cut parallel to the grain. In addition, special tensile tests were made that are believed to offer more promise than the standard tests for correlating coupon tests with tests on a complete structure. (See reference 3.) These special tests were made on strips having parallel sides, with the width arbitrarily chosen equal to the rivet pitch of the test panels, and having a hole in the center of the same size as the rivet holes along the stringers of the test panels. On one set of specimens the holes

were open; on a duplicate set the holes were filled with rivets. The special specimens were cut at  $45^\circ$  to the grain, because the sheet in the test panels is in a condition approaching pure diagonal tension when failure is imminent. The average ultimate tensile strengths of the coupons, based on the net areas, were as follows:

Standard specimens

0.020-inch sheet, ksi . . . . . 71.1

0.040-inch sheet, ksi . . . . . 71.6

Perforated specimens, holes open

0.020-inch sheet, ksi . . . . . 63.6

0.040-inch sheet, ksi . . . . . 63.0

Perforated specimens, holes filled

0.020-inch sheet, ksi . . . . . 64.2

0.040-inch sheet, ksi . . . . . 64.0

#### ANALYSIS OF TEST RESULTS

General remarks.- The results of the strength tests are given in table 2, and the results of the strain measurements are given in figure 3. The ultimate shear stress  $\tau_{ult}$  given in table 2 is the ultimate load  $P_{ult}$  divided by the net cross-sectional area. This stress is only nominally a shear stress, because the sheet is actually in a highly developed state of diagonal tension when failure takes place.

In a number of panels, cracks developed at loads averaging about 5 percent less than the ultimate loads. The differences between the loads for the first crack and the ultimate loads were about 2 percent for the basic panels with steel stringers and about 7 percent for the basic panels with aluminum-alloy stringers; the differences for the stiffened and the reinforced panels fell between these values. In the basic panels, the first cracks always occurred at the corners of the cut-outs; in the other panels, the first cracks appeared anywhere in the stiffened or reinforced region. Inasmuch as the detection of the first crack is difficult because the stringer may hide the crack, the data on cracking were not considered sufficient to warrant very definite conclusions, and the discussion is therefore confined to ultimate loads.

Basic panels.- An attempt was made to correlate the tests of the basic panels (no stiffening or reinforcement) by means of the formula and method given in reference 1. The curve of effective shear modulus against stress given in reference 1 was assumed to be valid, and trial-and-error calculations were made with assumed ultimate shear stresses. The correlation was poor, which was not surprising in view of the numerous uncertainties attending these calculations.

The calculations indicated stress-concentration factors ranging from 1.3 to 1.8. Inspection of the strain-gage data (fig. 3) indicated that stress-concentration factors as high as 1.8 did not exist. The experimental curves shown in figure 3 in a number of cases fail to agree even qualitatively with the theoretical curves. Instead of showing maximum stresses at the cut-out, these curves show maximum stresses located some distance away from the cut-out in some panels and essentially uniform distribution in other panels. The two halves of the panel in some cases showed marked differences in the strain distribution.

A peculiarity worth mentioning is exhibited by the strains measured in panel 16 near the cut-out (dashed lines, fig. 3). On either side of the cut-out, the second gage shows much lower strains than the first or the third gage. Panel 16 was the panel with the auxiliary stringer (see fig. 2(c)); the first and the third gage stations were located to one side of the auxiliary stringer, the second gage station to the other side, but there is no apparent reason why this difference in location should cause such a marked difference in strain.

Because of the wide divergences in the shapes of the curves (fig. 3), it appeared justifiable to replace the theory of reference 1 by the simplifying assumption that the shear stress is distributed uniformly over the entire length of the panel when failure is imminent. It may be expected that a uniform distribution will be approached more and more closely as the strains increase; and in panel 6, which had the highest strains measured, the distribution is indeed remarkably uniform. This uniformity is also evident visually from the uniform depth of the buckles along the entire length of the panels after failure (fig. 4).

If the assumption of uniform distribution of the shear stresses is valid, the ultimate shear stresses given in table 2 should compare directly with the allowable shear stress. For a sheet with a well-developed

diagonal-tension field, the allowable shear stress is a little over one-half of the allowable tensile stress (reference 3). If the coupon tests of the perforated tensile specimens with holes filled are used as a basis, and these tests seem the most rational choice, one-half of the allowable tensile stress is 32.1 ksi (average of both thicknesses). The average shear stress developed by test panels 1 to 9 and 11 is 33.7 ksi which is about 5 percent higher than the allowable value. Only one test panel (panel 7) developed an ultimate shear stress slightly lower than the allowable value. It may be concluded, therefore, that the lengthwise distribution of the ultimate shear stress was essentially uniform in all test panels regardless of length of cut-out, size of stringer, or thickness of sheet.

Panels with stiffening in critical bays.- The effectiveness of the various methods of stiffening the critical sheet bays was evaluated by noting the gain in ultimate shear stress over the stress developed by the corresponding basic specimens. The percentage gain is shown in table 2. The stiffener plates (panels 13 and 15) and the auxiliary stringers (panel 16) effected gains of 1 to 3 percent; these differences are within the experimental scatter and consequently are of little real significance. The gains effected by the transverse stiffener angles (panels 12 and 14) were 8 to 9 percent. The amount of stiffening used, however, would be considered excessive in practice, inasmuch as the angles were placed so close that they almost touched each other. It seems probable that more reasonable amounts of stiffening would show gains of the order of only 2 to 4 percent. Somewhat larger gains might be effected in practice if the failure were not caused by tearing of the sheet, as in these panel tests, but by rivets pulling through the sheet; when failure occurs by rivets pulling through the sheet, the potential strength of the material is obviously not being utilized and appreciable gains are consequently possible. If the strength of the material is already fully utilized in diagonal tension, gains can be made by reducing the development of the diagonal-tension buckles to take advantage of the higher allowable stress in a less completely developed diagonal-tension field (reference 3), but these gains will be only moderate.

Panels with reinforcements in critical bays.- The test panels having reinforced sheet bays were first

analyzed on the assumption that the stress was uniformly distributed over the entire net area (including that of the reinforcements). The ultimate stresses calculated on this assumption were found to be appreciably lower than those found for the basic specimens. If the ultimate stress developed in a reinforced panel is assumed equal to that developed in a panel without reinforcement, efficiency factors may be calculated for the doubler plates. These efficiencies are given in table 2 and are noted to vary widely. The number of tests was too small, however, to establish the reasons for the variations.

#### SUGGESTED DESIGN PROCEDURE

The results of the tests appear to justify the assumption that the shear stress in a sheet bay with a cut-out is uniformly distributed over a considerable length of the structure, provided the proportions of the actual structure do not deviate too much from the proportions of the test panels. The length over which the shear stress is considered to be uniformly distributed, which may be termed the distribution length, depends on all the parameters involved.

General knowledge of stress-distribution problems and experience with these problems indicate that the most important single item determining the distribution length is the width of the cut-out. The tests indicate that the distribution length on each side of the cut-out is equal to at least 11 times the width of the cut-out. In order to obtain a conservative design rule, it is therefore suggested that the distribution length be assumed equal to 10 times the width of the cut-out unless the actual length is less, in which case the distribution length should be taken as equal to the actual length. Full allowance should be made for the presence of the rivet holes along the stringers. The allowable shear stress should be taken as one-half of the ultimate tensile stress of the material at  $45^\circ$  to the grain and should be reduced to account for the stress-concentration effect of the rivet holes (about 10 percent for 24S-T aluminum alloy). Until more test evidence is available, reinforcing doubler plates should not be assumed to have more than 30 percent efficiency if these plates extend only to the stringers bounding the cut-out or 70 percent if they extend to the adjacent stringers. (See table 2.)

The suggested design procedure should be somewhat conservative provided the proportions do not differ too greatly from those of the test panels and provided the detail design is such that failure is caused by tearing of the sheet. A complete design procedure would include considerations of the compressive or tensile strength of the stringers near the cut-out, of the possibility of the rivets pulling through the sheet, of lateral bending in the stringers along the edge of the cut-out caused by diagonal tension in the adjoining bays, and of local weaknesses caused by discontinuities, for example, when the transverse ribs are intercostal.

### CONCLUSIONS

Results of shear tests of skin-stiffener panels with inspection cut-outs are believed to justify the following conclusions:

1. When a skin-stiffener panel with an inspection cut-out approaches its ultimate strength under shear loading, the shear stress in the interrupted sheet bay approaches uniform distribution over a considerable distance.
2. The efficiency of doubler plates is low.

Langley Memorial Aeronautical Laboratory  
National Advisory Committee for Aeronautics  
Langley Field, Va.

## REFERENCES

1. Kuhn, Paul: Skin Stresses around Inspection Cut-Outs. NACA ARR, Dec. 1941.
2. Moggio, Edwin M., and Brilmyer, Harold G.: A Method for Estimation of Maximum Stresses around a Small Rectangular Cut-Out in a Sheet-Stringer Panel in Shear. NACA ARR No. L4D27, 1944.
3. Kuhn, Paul: Ultimate Stresses Developed by 24S-T Sheet in Incomplete Diagonal Tension. NACA TN No. 333, 1941.

TABLE 1.- TEST PANELS

[Width of cut-out, 3.188 inches for all panels.  
For other dimensions of basic panels, see figure 1.]

NATIONAL ADVISORY  
COMMITTEE FOR AERONAUTICS

| Panel<br>(a)                                | Type<br>(See<br>fig. 1.) | Thickness<br>of<br>sheet<br>(in.) | Stringer            |   | Length of<br>cut-out<br>(in.) | Net cross-<br>sectional<br>area<br>(sq in.) | Remarks  |
|---|--------------------------|-----------------------------------|---------------------|---|-------------------------------|---|--|
|   |                          |                                   | Material            | Cross-<br>sectional<br>area<br>(sq in.) |                               |   |  |
| Basic panels                                |                          |                                   |                     |   |                               |   |  |
| 1   | 1                        | 0.0208                            | 2 $\frac{1}{2}$ S-T | 0.0833                                  | 18                            | 1.058                                       | } Edge bays reinforced by doubler plates<br>to ensure failure along stringer |
| 2   | 1                        | .0214                             | 2 $\frac{1}{2}$ S-T | .0859                                   | 18                            | 1.076                                       |  |
| 3   | 2                        | .0214                             | 2 $\frac{1}{2}$ S-T | .0358                                   | 15                            | .955  |  |
| 4   | 2                        | .0213                             | 2 $\frac{1}{2}$ S-T | .0350                                   | 15                            | .970  |  |
| 5   | 2                        | .0205                             | 2 $\frac{1}{2}$ S-T | .0835                                   | 15                            | .925  |  |
| 6   | 2                        | .0206                             | Steel               | .4722                                   | 15                            | .929  |  |
| 7   | 2                        | .0208                             | Steel               | .4500                                   | 7 $\frac{3}{4}$               | 1.061                                       |  |
| 8   | 2                        | .0205                             | Steel               | .4500                                   | 3                             | 1.127                                       |  |
| 9   | 2                        | .0206                             | Steel               | .4530                                   | No cut-out                    | 1.184                                       |  |
| 10  | 2                        | .0403                             | 2 $\frac{1}{2}$ S-T | .0792                                   | 15                            | 1.813                                       |  |
| 11  | 2                        | .0404                             | Steel               | .3825                                   | 15                            | 1.817                                       |  |
| Panels with stiffening in critical bays     |                          |                                   |                     |   |                               |   |  |
| 12(a)                                       | 1                        | 0.0208                            | 2 $\frac{1}{2}$ S-T | 0.0833                                  | 18                            | 1.058                                       | Transverse stiffener angles  |
| 13(b)                                       | 1                        | .0209                             | 2 $\frac{1}{2}$ S-T | .0831                                   | 18                            | 1.062                                       | Stiffener plate  |
| 14(a)                                       | 2                        | .0212                             | 2 $\frac{1}{2}$ S-T | .0358                                   | 15                            | .955  | Transverse stiffener angles  |
| 15(b)                                       | 2                        | .0212                             | 2 $\frac{1}{2}$ S-T | .0858                                   | 15                            | .955  | Stiffener plate  |
| 16(a)                                       | 2                        | .0205                             | 2 $\frac{1}{2}$ S-T | .0839                                   | 15                            | .922  | Auxiliary stringer   |
| Panels with reinforcements in critical bays |                          |                                   |                     |   |                               |   |  |
| 17(d)                                       | 1                        | 0.0214                            | 2 $\frac{1}{2}$ S-T | 0.0857                                  | 18                            | 1.622                                       | Small doubler plate on both sides<br>of sheet                                |
| 18(d)                                       | 2                        | .0212                             | 2 $\frac{1}{2}$ S-T | .0358                                   | 15                            | 1.268                                       | Small doubler plate on one side<br>of sheet                                  |
| 19(e)                                       | 2                        | .0213                             | 2 $\frac{1}{2}$ S-T | .0350                                   | 15                            | 1.283                                       | Large doubler plate on one side<br>of sheet                                  |

\*Letters in parentheses refer to corresponding stiffeners and reinforcements shown in figure 2.

TABLE 2.--TEST RESULTS

| Panel<br>(a)                                | P <sub>ult</sub><br>(kips) | T <sub>ult</sub><br>(ksi) | Gain over<br>basic<br>(percent) | Efficiency of<br>doubler plate<br>(percent) |
|---|----------------------------|---------------------------|---------------------------------|---|
| Basic panels                                |                            |                           |                                 |   |
| 1   | 36.5                       | 34.5                      |                                 |   |
| 2   | 36.3                       | 33.7                      |                                 |   |
| 3   | 32.3                       | 33.8                      |                                 |   |
| 4   | 31.8                       | 32.8                      |                                 |   |
| 5   | 31.2                       | 33.8                      |                                 |   |
| 6   | 31.8                       | 34.2                      |                                 |   |
| 7   | 33.6                       | 31.7                      |                                 |   |
| 8   | 30.8                       | 32.7                      |                                 |   |
| 9   | 40.8                       | 34.5                      |                                 |   |
| 10  | 56.7                       | <sup>b</sup> 31.3         |                                 |   |
| 11  | 63.5                       | 34.9                      |                                 |   |
| Panels with stiffening in critical bays     |                            |                           |                                 |   |
| 12(e)                                       | 39.8                       | 37.6                      | 9                               |   |
| 13(b)                                       | 37.3                       | 35.1                      | 2                               |   |
| 14(a)                                       | 34.6                       | 36.2                      | 8                               |   |
| 15(b)                                       | 32.5                       | 34.0                      | 1                               |   |
| 16(c)                                       | 32.0                       | 34.7                      | 3                               |   |
| Panels with reinforcements in critical bays |                            |                           |                                 |   |
| 17(d)                                       | 43.1                       | 26.6                      |                                 | 31  |
| 18(d)                                       | 36.5                       | 28.8                      |                                 | 60  |
| 19(e)                                       | 39.8                       | 31.0                      |                                 | 73  |

<sup>a</sup>Letters in parentheses refer to corresponding stiffeners and reinforcements shown in figure 2.

<sup>b</sup>Premature failure (collapse of stiffener angle at upper end of panel).



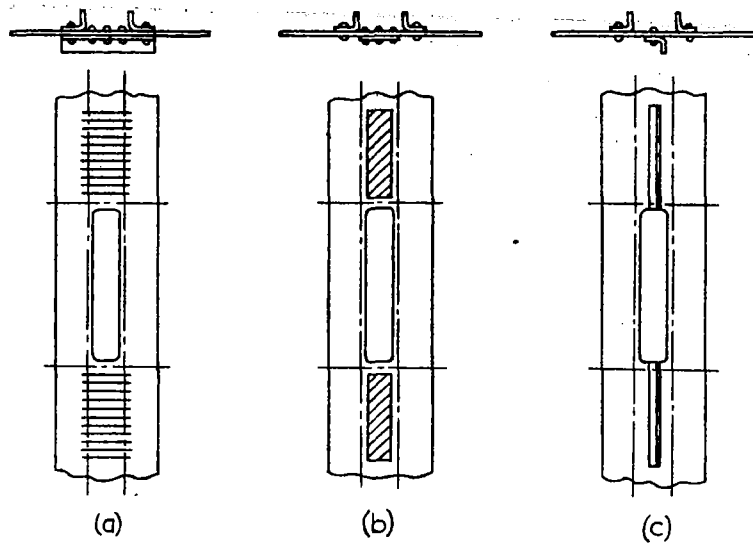

Critical bays stiffened

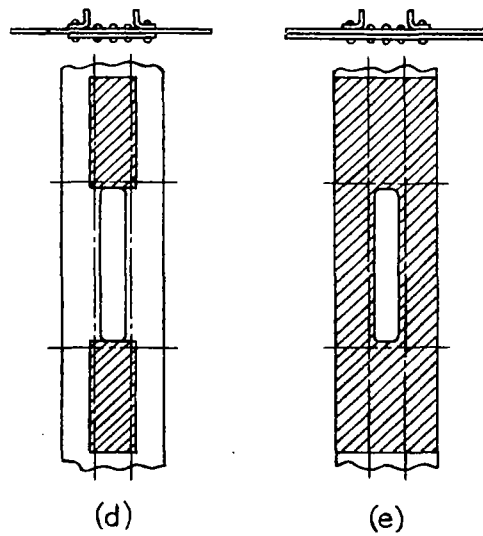

Critical bays reinforced

NATIONAL ADVISORY  
COMMITTEE FOR AERONAUTICS

Figure 2:-Diagrams showing stiffening and reinforcement of critical bay.  
(Note that cross sections are double size.)

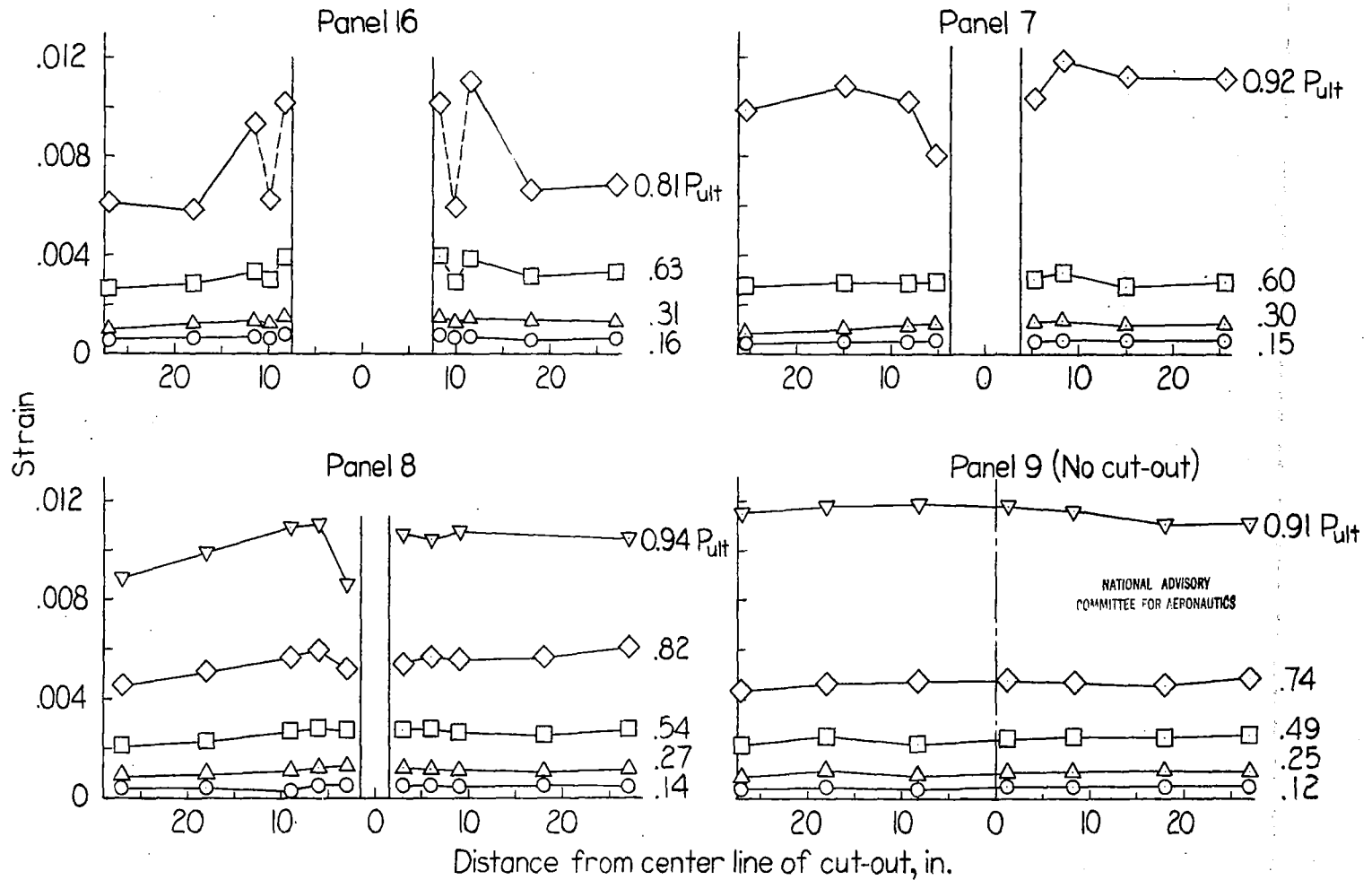

Figure 3.-Lengthwise distribution of strain.

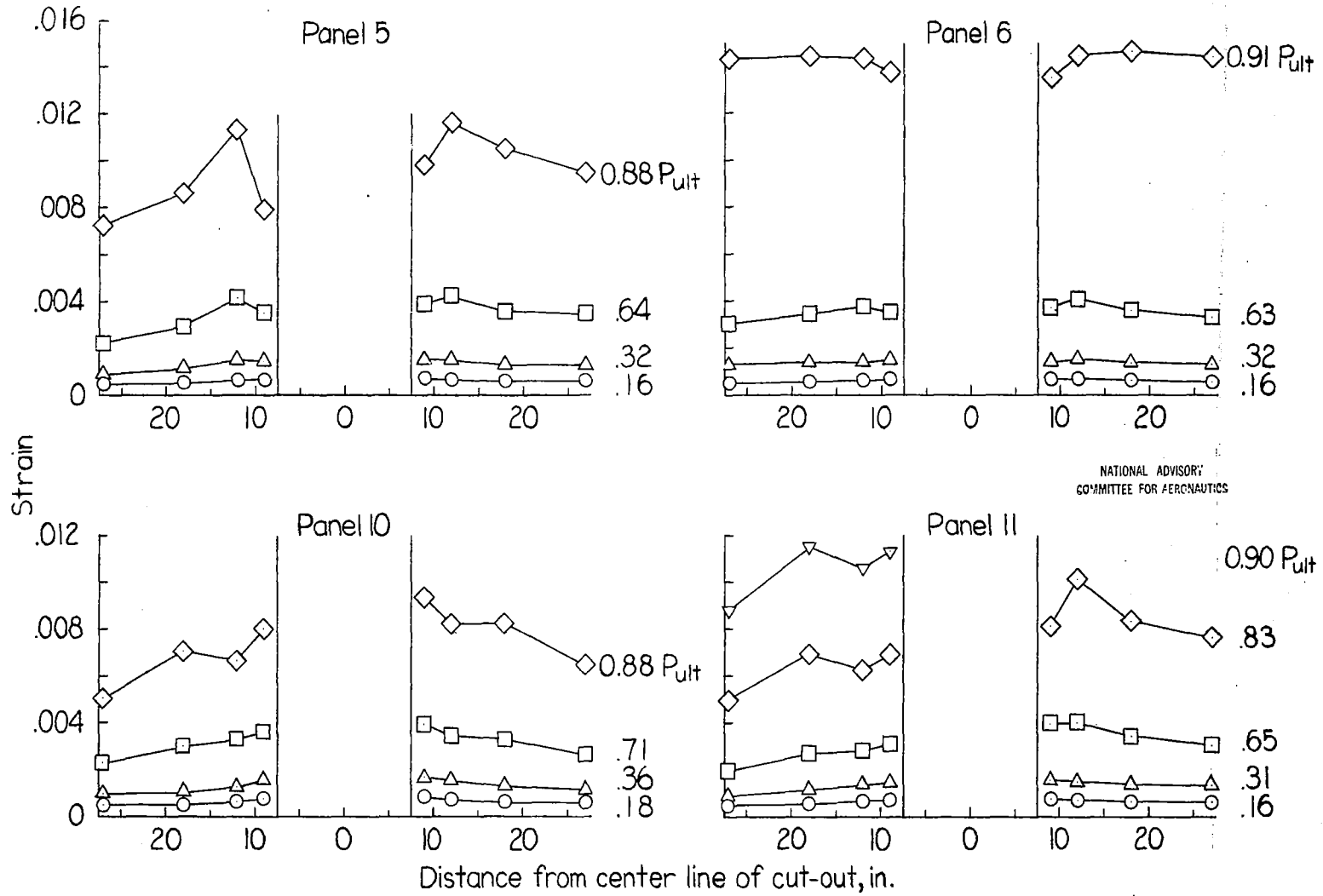

Figure 3.- Concluded.



NACA LMAL  
375351

NACA LMAL  
375361

Panel 5

Panel 6

Panel 5

Panel 6

(a) Front view.

(b) Rear view.

Figure 4.- Test panels of type 2 after failure.

FD-117 FORM 69 (13 MAR 47)

Kuhn, Paul  
Diskin, Simon H.

R-7-3-19

DIVISION: Stress Analysis and Structures (7)  
SECTION: Structural Design and Details (3)  
CROSS REFERENCES: Panels, Stiffened - Strength (68747.7)

ATI- 7552

ORIG. AGENCY NUMBER

ARR-15001a

REVISION

AUTHOR(S)

AMER. TITLE: On the shear strength of skin stiffener panels with inspection cut-outs

FORG'N. TITLE:

ORIGINATING AGENCY: National Advisory Committee for Aeronautics, Washington, D. C.

TRANSLATION:

| COUNTRY | LANGUAGE | FORG'N. CLASS. | U. S. CLASS. | DATE   | PAGES | ILLUS. | FEATURES                     |
|---------|----------|----------------|--------------|--------|-------|--------|------------------------------|
| U.S.    | Eng.     | .              | Unclass.     | Mar'45 | 16    | 7      | photos, tables, graphs, drug |

ABSTRACT

Strength tests and strain measurements were made of 19 long, skin-stiffener panels of 24S-T aluminum alloy with rectangular inspection cut-outs in center. When ultimate strength is reached under shear loading, the shear stress in the interrupted sheet bay approaches uniform distribution over a considerable distance. Stiffening of the sheet bay was found to have practically no effect on panel strength. Efficiency of doubler plates is low.

NOTE: Requests for copies of this report must be addressed to: N.A.C.A., Washington, D. C.

STRESS ANALYSIS