

DEC 23 1946

copy 1

NATIONAL ADVISORY COMMITTEE FOR AERONAUTICS

WARTIME REPORT

ORIGINALLY ISSUED

March 1945 as
Advance Restricted Report L5C09

SPIN-TUNNEL TESTS OF AIRPLANE MODELS WITH EXTREME
VARIATIONS IN MASS DISTRIBUTION
ALONG THE THREE BODY AXES

By Robert W. Kamm

Langley Memorial Aeronautical Laboratory
Langley Field, Va.

NACA

WASHINGTON

N A C A LIBRARY
LANGLEY MEMORIAL AERONAUTICAL
LABORATORY
Langley Field, Va.

NACA WARTIME REPORTS are reprints of papers originally issued to provide rapid distribution of advance research results to an authorized group requiring them for the war effort. They were previously held under a security status but are now unclassified. Some of these reports were not technically edited. All have been reproduced without change in order to expedite general distribution.

NATIONAL ADVISORY COMMITTEE FOR AERONAUTICS

ADVANCE RESTRICTED REPORT

SPIN-TUNNEL TESTS OF AIRPLANE MODELS WITH EXTREME
VARIATIONS IN MASS DISTRIBUTION
ALONG THE THREE BODY AXES

By Robert W. Kamm

SUMMARY

An investigation was conducted in the Langley 15-foot and 20-foot free-spinning tunnels to determine the effect of extreme changes in mass distribution along each of the three body axes. Two models of single-engine airplanes having different geometric arrangements and aerodynamic characteristics were tested with a series of different loadings. The test results were analyzed to investigate the effects of the individual inertia moment parameters upon spin and recovery characteristics.

The test results indicated that the value of the inertia yawing-moment parameter mainly determined the effect of aileron setting on recovery, that the values of the inertia yawing-moment and inertia rolling-moment parameters influenced the effect of elevator setting on recovery, and that the value of the inertia pitching-moment parameter determined the attitude of the spin at the normal spinning control configuration (ailerons neutral, elevators up, and rudder full with the spin) when mass was distributed chiefly along the wing. The inertia pitching-moment parameter also determined the angular velocities of the spins. Steady spins could not be maintained when all three moments of inertia were equal.

INTRODUCTION

Existing literature on spinning indicates that mass distribution may greatly affect the spin and recovery characteristics of a given airplane. Some of the previous

██████████

investigations of the effect of mass distribution on spinning have been presented in references 1 to 5.

The previous work has indicated that the mass distribution of airplanes determines the relative effectiveness of the various controls in producing recovery from spins. Although geometric characteristics have affected the number of turns for recovery from a spin, they generally have not influenced the relative effectiveness of the controls in producing recovery for a given loading condition.

Reference 1 indicates that the inertia yawing-moment parameter may be used to predict the relative effectiveness of various control settings and movements on recovery. In reference 2 it is indicated that multiengine models spin steeply, that aileron-against settings expedite recovery, and that the elevator is the most effective single control for recovery. Multiengine models have relatively more mass along the wing and less mass along the fuselage than single-engine models; that is, the inertia yawing-moment parameter is positive for multiengine models and is generally negative for single-engine models. Single-engine models may spin either steeply or flatly, aileron-with settings expedite recovery, and the rudder is the most effective single control for recovery. It was shown in reference 3 that, when the loading along the wings was increased for several single-engine models until the inertia yawing-moment parameter was positive, control effects typical of multiengine models were obtained but the spins were not so steep as the spins that are characteristic of multiengine models.

Inasmuch as previous work indicated the effect of only the inertia yawing-moment parameter, the present investigation was conducted in the Langley 15-foot and 20-foot free-spinning tunnels in an attempt to determine the effects of the inertia rolling-moment and inertia pitching-moment parameters. A primary purpose of this investigation was to determine which inertia moment parameter determines the attitude of the spin. The scope of some of the previous investigations is shown in figure 1, which indicates the envelopes of the inertia moment parameters of the models considered in the investigations of references 1 to 3. The inertia moment parameters of most of the models of conventional airplanes tested in the Langley spin tunnels since the investigation described in reference 1 lie within or quite close

to the envelope indicated for reference 1. Figure 1 also shows the loading conditions as represented by the inertia moment parameters with which the models were tested in the present investigation. Very extreme changes in the loading along the three body axes were made in the present investigation with the hope that the results obtained at the extreme conditions would be of aid in isolating the effects of the individual inertia moment parameters. Additional tests were made with the moments of inertia about the three body axes equal in order to determine the effect of zero inertia moment parameters. Tests were also made to determine the effect of increasing all moments of inertia by equal amounts and thus keeping the moment-of-inertia differences constant. Two models having different geometric characteristics were tested in order to determine whether aerodynamic differences would influence the effect of the large loading changes.

The effects of control settings on the steady-spin and recovery characteristics were determined for the various loadings. The center-of-gravity location was held fixed, and the total weight was kept constant for each model during the test program. All tests were made with the landing gear and flaps retracted.

SYMBOLS

X, Y, and Z	airplane body axes
m	mass, slugs
b	wing span, feet
S	wing area, square feet
I_x	moment of inertia about X-axis, slug-feet ²
I_y	moment of inertia about Y-axis, slug-feet ²
I_z	moment of inertia about Z-axis, slug-feet ²
k_x	radius of gyration about X-axis, feet
k_y	radius of gyration about Y-axis, feet

k_z	radius of gyration about Z-axis, feet
V	airplane true rate of descent estimated by scaling from model values, feet per second
α	acute angle between thrust axis and vertical (approx. equal to absolute value of angle of attack at plane of symmetry), degrees
ϕ	angle between Y-axis and horizontal, degrees
Ω	airplane angular velocity about spin axis estimated by scaling from model values, radians per second
ρ	density of air, slugs per cubic foot
p	angular velocity about X-axis, radians per second
q	angular velocity about Y-axis, radians per second
r	angular velocity about Z-axis, radians per second
t	time, seconds
$\frac{k_x^2 - k_y^2}{b^2}$	inertia yawing-moment parameter
$\frac{k_y^2 - k_z^2}{b^2}$	inertia rolling-moment parameter
$\frac{k_z^2 - k_x^2}{b^2}$	inertia pitching-moment parameter

EQUATIONS OF MOTION APPLICABLE TO SPINNING

If the airplane body axes are assumed to coincide with the principal axes, as is very nearly the case for

conventional airplanes, Euler's equations for the moments acting on a rotating body may be written for an airplane in a spin as

$$\begin{aligned} \text{Inertia yawing moment} &= - \text{Aerodynamic yawing moment} \\ &= (I_X - I_Y)pq - I_Z \frac{dr}{dt} \end{aligned}$$

$$\begin{aligned} \text{Inertia rolling moment} &= - \text{Aerodynamic rolling moment} \\ &= (I_Y - I_Z)qr - I_X \frac{dp}{dt} \end{aligned}$$

$$\begin{aligned} \text{Inertia pitching moment} &= - \text{Aerodynamic pitching moment} \\ &= (I_Z - I_X)pr - I_Y \frac{dq}{dt} \end{aligned}$$

In a steady spin, the acceleration terms (the last terms in the equations) disappear; the formulas indicate, therefore, that the individual moments of inertia may affect recoveries although they should have no effect on the steady spin. The moment-of-inertia differences determine the inertia moments acting during a steady spin at a given attitude and given angular velocities. These differences may be expressed nondimensionally by the inertia moment parameters

$$\frac{I_X - I_Y}{mb^2}$$

$$\frac{I_Y - I_Z}{mb^2}$$

$$\frac{I_Z - I_X}{mb^2}$$

or by

$$\frac{k_X^2 - k_Y^2}{b^2}$$

$$\frac{k_Y^2 - k_Z^2}{b^2}$$

$$\frac{k_Z^2 - k_X^2}{b^2}$$

APPARATUS AND TESTS

Apparatus and Geometric Characteristics of Models

Testing technique and construction of spin models are described in reference 6. Dimensions of the airplanes represented by the two models used for the present tests are given in table I. Three-view drawings of the

models, which are designated A and B, are presented in figures 2 and 3, and photographs of the models are given as figures 4 and 5. The tests were made with the landing gear retracted. Model A represents a recent scout-bomber airplane and model B represents a recent experimental fighter design. The scales were 1/18 for model A and 1/20 for model B.

Mass Loadings Tested

The initial loading conditions of the models, as represented by the inertia moment parameters, were almost the same. In order to obtain the other loading conditions tested, lead ballast was redistributed along the three body axes. The total weight of each model and the center-of-gravity location were held constant. Extending or retracting mass along any one axis increases or decreases the moments of inertia about the other two axes and therefore changes two of the inertia moment parameters, as is shown by the following table:

Extending mass along	Change in			Algebraic change in		
	I_X	I_Y	I_Z	$\frac{k_X^2 - k_Y^2}{b^2}$	$\frac{k_Y^2 - k_Z^2}{b^2}$	$\frac{k_Z^2 - k_X^2}{b^2}$
X-axis	-----	Increase	Increase	Decrease	-----	Increase
Y-axis	Increase	-----	Increase	Increase	Decrease	-----
Z-axis	Increase	Increase	-----	-----	Increase	Decrease

The three inertia moment parameters therefore are inter-related, and any two parameters determine the third. It is impossible to vary only one parameter at a time and determine its effect.

In most cases it was impossible to make the desired retraction of mass along any one axis, and accordingly changes that gave the desired values of the inertia moment parameters were obtained by extending mass along the other two axes. In order to change appreciably the mass distribution along the Z-axis, weights were installed on rods that passed through the center of gravity and projected into the air stream. Tests indicated that the effect of the rods on the spin and recovery characteristics was small.

In tables II and III, which show the various loading conditions simulated on models A and B, respectively, the actual changes made to obtain the various loadings and the effective changes thus simulated are given. Tests for models A and B were made at equivalent spin altitudes of 6000 and 8000 feet, respectively.

Accuracy

Because the models were damaged frequently during the tests, it was recognized that the results obtained were primarily of qualitative value and were not accurate enough to permit rigid quantitative comparisons. Check tests with the models in the initial loading condition were made at the end of the test program, however, and the results agreed reasonably well with the original results. For some loadings and control configurations, the results obtained may have been influenced by sensitivity to small variations in control settings - especially at conditions for which the results varied greatly with changes in aileron and elevator setting.

PRESENTATION OF RESULTS

The detailed test results are presented in charts 1 and 2 for models A and B, respectively. The boxes on the charts give the steady-spin and recovery characteristics for principal combinations of aileron and elevator settings. The keys in the lower right-hand corners of the charts show the order of presentation of the results in the boxes. All recoveries were attempted by full rapid rudder reversal, and the recovery characteristics were determined by the number of turns the model made from the time the rudder was fully reversed until the spin rotation ceased.

A simplified presentation of the results, which shows directly the effects of changes in mass distribution on the optimum direction of aileron and elevator setting for recovery, on the angle of attack, on the angle between the Y-axis and the horizontal, and on the turns for recovery from the spin at the normal spinning control configuration (ailerons neutral, elevators up, and rudder full with the spin), is given in figure 6 for model A and in figure 7 for model B. In these figures, a question

mark indicates that the aileron or elevator setting had little apparent effect on recovery. Quantitative results are given in figures 6 and 7 only for the spin at the normal control configuration for spinning. The quantitative effects of the changes in mass distribution on the spins obtained with other combinations of aileron and elevator settings can be determined from charts 1 and 2.

DISCUSSION

Initial Loading Conditions

For the present tests, the initial loadings of the models corresponded approximately to the basic loadings of the airplanes represented by the models. These loadings were arbitrarily selected as convenient starting points for the test program and are fairly representative of single-engine airplanes.

For both models in the initial loading condition (condition 1), aileron-with spins (right aileron up and left aileron down in a right spin) were very steep with high angular velocities and recoveries were rapid. Aileron-neutral and aileron-against spins were fairly flat and recoveries from these spins were slower than from aileron-with spins. For model B, elevator-down settings retarded recovery whereas, for model A, elevator setting apparently had only little effect on the general spin characteristics. The difference in the effect of elevator setting for the two models at almost the same loading conditions was probably caused by the aerodynamic differences in the models.

Variations in Mass along Body Axes

Along X-axis.- Figure 6 shows that for model A an extreme extension of mass along the X-axis (condition 2) had little effect on the spin characteristics. A further large extension of the mass distributed along the X-axis (condition 3) prevented the model from spinning except when the ailerons were set against the spin. Retracting the mass distributed along the X-axis (condition 4) steepened the spin at the normal control configuration, increased the angular velocity, prevented the model from

spinning with the elevator neutral or down, and reversed the effect of aileron setting on recovery from that obtained at normal loading since, in this condition, aileron-against settings gave the most rapid recoveries.

The results obtained for model B (fig. 7) were generally similar to those obtained for model A.

Along Y-axis.- For both models, retracting mass along the wing accentuated the effect of aileron setting on recovery, and extending mass along the wing reversed the effect of aileron setting on recovery. No consistent variation in angle of attack with the mass variations was apparent.

Along Z-axis.- For both models, either retracting mass along the Z-axis (condition 10) or extending mass along the Z-axis (condition 8) retarded recovery from the spin at the normal control configuration. The angle of attack did not change appreciably as mass was varied along the Z-axis. The results shown in charts 1 and 2 show that retracting mass along the Z-axis tended to make the aileron-with spins flat and that extending mass along the Z-axis tended to increase the angle of bank and caused the models to spin with the inner wing inclined up considerably. At condition 9, the change in mass distribution from the initial value was greater for model A than for model B (see fig. 1) and, whereas model A would not spin for any combination of aileron and elevator control settings, spins were obtained for model B when the ailerons were neutral or with the spin and the elevators were neutral or down. During these spins the fuselage was nearly horizontal, and the inner wing was up approximately 45° . Recoveries from these spins varied considerably, and the model tumbled - that is, rotated about the Y-axis - during recovery. An explanation for the fact that model A would not spin at condition 9 may be that the inertia pitching-moment parameter was zero and therefore no inertia couple acted to flatten the model and hold it in a spinning attitude.

Special Loading Conditions

Equal moments of inertia.- Tests made with all moments of inertia equal (condition 11), so that there would be no inertia moments acting during the spin, resulted in conditions for both models for which steady

spins could generally not be obtained. When the elevators were up and the ailerons were neutral or with the spin, however, model A continued to rotate and the value of α varied between limits of -4° and 46° and the wing inclination varied between limits of 30° up (inner wing) and 18° down. Reversal of the rudder terminated the motion rapidly. With the same control settings, model B descended at a velocity too high to permit testing.

Increased moments of inertia.- In an attempt to determine the importance of the moments of inertia as compared with the moment-of-inertia differences, all three moments of inertia were increased by equal increments from the initial single-engine loading conditions so that the inertia moment parameters remained constant at the initial values. The results obtained at this loading (condition 13) indicated little effect of the increases in moments of inertia upon either the steady spin or the recoveries obtained by rudder reversal.

Typical multiengine loading.- Loading conditions that were considered representative of the mass distribution of multiengine airplanes were obtained by extending weight along the wing and effectively retracting weight along the fuselage (condition 12). The control effects obtained were typical of multiengine models in that aileron-against and elevator-down settings tended to prevent the spin. The aileron-with spins obtained were much flatter than the corresponding spins for the initial loadings; however, the spins obtained with ailerons against and at the normal spinning control configuration were steeper.

Effect of Aerodynamic Differences in Models

The two models tested differed somewhat in aerodynamic characteristics as measured by the tail damping-power factor (see table I) and in other respects such as wing location. These aerodynamic differences were large enough to cause some differences in the test results. For model A in the initial loading condition, for example, elevator setting had little effect on recovery, whereas for model B elevator-up settings expedited recovery. Model A had a partial-length rudder so that deflecting the elevators either up or down did not appreciably change the shielding effect of the horizontal tail on the rudder during spins. Model B, however, had a full-length rudder and, when the

elevators were down, more of the rudder was shielded by the horizontal tail than when the elevators were up, with the result that the rudder was less effective in producing recovery. For both models the spins were somewhat steeper with the elevators down than with the elevators up, an indication that deflecting the elevators gave an increment in pitching moment even though they were stalled.

With the greatest extension of mass along the X-axis tested for model A (condition 3), the model would spin when the ailerons were set against the spin; model B at condition 2 (which was not so extreme a loading as condition 3 for model A), however, would not spin for any aileron-elevator combination even when the rudder was full with the spin. It was thought that these results might be attributed to the difference in the longitudinal stability characteristics of the models. Extension of mass along the fuselage increases the spin-flattening moment acting during a spin and, at very large angles of attack, the aerodynamic pro-spin moments have been found to become very small (reference 7). For model B at condition 2 the spin-flattening moment evidently was large enough to cause the model to assume such a flat attitude that spinning equilibrium was not possible. It was also noticed that the ratio of horizontal-tail area to wing area was considerably smaller for model B than for model A. Brief tests were therefore made with the stabilizer area increased for model B (aerodynamic diving moment increased), and spins were obtained when the ailerons were against the spin.

For the two models, variations in mass distribution along the Y-axis had opposite effects on the attitude of the spin at the normal control configuration for spinning. For model A, extending mass along the Y-axis steepened this spin and, for model B, retracting mass along the Y-axis steepened the spin. The reason for this difference is not apparent.

Either extending or retracting mass along the Z-axis of model B caused the spins with the ailerons against the spin (elevators neutral or down) to become very oscillatory in pitch and roll. This effect was not obtained for model A.

It should be remembered that other models which differed greatly in aerodynamic characteristics from the two models tested might have given results that were

somewhat different from the present results. The indications are, however, that the effects of the mass changes on the relative effectiveness of the controls in producing recovery would have been the same.

Effect of Individual Inertia Moment Parameters

Certain inferences concerning the effects of the individual inertia moment parameters can be made from the preceding results. It appears that, as was previously indicated and explained in reference 1, the directions of aileron and elevator deflections for optimum recovery vary with the value of the inertia yawing-moment parameter $\frac{k_x^2 - k_y^2}{b^2}$. Figures 6 and 7 show that, when mass was distributed chiefly along the wing $\left(\frac{k_x^2 - k_y^2}{b^2} \text{ positive}\right)$, elevator-down and aileron-against settings generally were favorable to rapid recovery whereas, when mass was distributed chiefly along the fuselage $\left(\frac{k_x^2 - k_y^2}{b^2} \text{ negative}\right)$, elevator-up and aileron-with settings were, in most cases, favorable to recovery.

Varying the mass along the wing (conditions 1, 5, 6, and 7) had little consistent effect on the attitude of the spin at the normal control configuration - an indication that, for a constant value of the inertia pitching-moment parameter, variations of the inertia rolling-moment or inertia yawing-moment parameters do not affect the spin attitude. This result agrees with conclusion 1 of reference 3. When mass was distributed chiefly along the wing (inertia yawing-moment parameter positive), the inertia pitching-moment parameter $\frac{k_z^2 - k_x^2}{b^2}$ determined the attitude of the spin at the normal spinning control configuration; low values of the parameter resulted in steep spins. A simple qualitative explanation for this steepening of the spin is that, when mass was effectively added along the Z-axis, the centrifugal forces acting on the mass along the Z-axis gave a pitching moment that nosed the model down.

When mass was distributed chiefly along the fuselage, the spin attitude did not vary consistently with any parameter until the inertia pitching-moment parameter was made so large or so small that spinning equilibrium could not be maintained.

A general comparison of all results indicates that the inertia pitching-moment parameter also influenced the angular velocities of the spins; low values of the parameter generally gave high angular velocities.

When mass was distributed chiefly along the fuselage (inertia yawing-moment parameter negative), the adverse effect on recovery of setting the elevators down was emphasized as the inertia rolling-moment parameter

$\frac{k_Y^2 - k_Z^2}{b^2}$ approached zero.

CONCLUSIONS

An investigation was conducted to determine the effect of extreme changes in mass distribution along each of the three body axes for two models of single-engine airplanes having different geometric arrangements and aerodynamic characteristics. The test results were analyzed to investigate the effects of the individual inertia moment parameters upon spin and recovery characteristics. It was recognized that the extent to which the spin would be affected by mass changes would depend upon the aerodynamic characteristics of the design. The test results indicated the following qualitative conclusions:

1. The value of the inertia yawing-moment parameter mainly determined the effect of aileron setting on recovery, and the values of both the inertia yawing-moment and the inertia rolling-moment parameters influenced the effect of elevator setting on recovery.

2. When mass was distributed chiefly along the wing (inertia yawing-moment parameter positive), the inertia pitching-moment parameter determined the attitude of the spin at the normal spinning control configuration.

3. The value of the inertia pitching-moment parameter determined the angular velocities of the spins.

4. The moment-of-inertia differences were apparently of primary importance in determining the spin and recovery characteristics of a given design. The magnitudes of the individual moments of inertia appeared to be of secondary importance.

5. Steady spins generally could not be maintained when all three moments of inertia were equal.

Langley Memorial Aeronautical Laboratory
National Advisory Committee for Aeronautics
Langley Field, Va.

REFERENCES

1. Nelhouse, A. I.: A Mass-Distribution Criterion for Predicting the Effect of Control Manipulation on the Recovery from a Spin. NACA ARR, Aug. 1942.
2. Seidman, Oscar, and Kamm, Robert W.: Multiengine Airplane Spin Characteristics as Indicated by Model Tests in the Free-Spinning Wind Tunnel. NACA ARR, July 1942.
3. Kamm, Robert W.: The Effect of Spanwise Mass Distribution upon the Spin Characteristics of Airplanes as Determined by Model Tests Conducted in the Free-Spinning Wind Tunnel. NACA ARR, Aug. 1942.
4. Scudder, Nathan F.: A Study of Factors Affecting the Steady Spin of an Airplane. NACA TN No. 468, 1933.
5. Gates, S. B., and Francis, R. H.: An Analytical Survey of the Effect of Mass Distribution on Spinning Equilibrium. R. & M. No. 1644, British A.R.C., 1934.
6. Zimmerman, C. H.: Preliminary Tests in the N.A.C.A. Free-Spinning Wind Tunnel. NACA Rep. No. 557, 1936.
7. Knight, Montgomery, and Wenzinger, Carl J.: Rolling Moments Due to Rolling and Yaw for Four Wing Models in Rotation. NACA Rep. No. 379, 1931.
8. Seidman, Oscar, and Donlan, Charles J.: An Approximate Spin Design Criterion for Monoplanes. NACA TN No. 711, 1939.

TABLE I

DIMENSIONS OF AIRPLANES REPRESENTED BY MODELS

	Model A	Model B
Wing span, ft	39	35
Over-all length, ft	27.8	29.8
Normal weight, lb	6450	6340
Normal c.g. location, percent M.A.C.	29.1	31.5
Wing:		
Area, sq ft	259	232
Section		
Root	NACA CYH, 18 percent thick	NACA 0015
Tip	NACA CYH, 11.8 percent thick	NACA 23009 modified
Root (reference) chord, in.	98.7	100.0
Root-chord incidence, deg	0	2
Tip-chord incidence, deg	0	2
Aspect ratio	5.9	5.3
Sweepback of L.E. of wing, deg	1.6 (approx.)	3.6
Dihedral at 30 percent chord line, deg	Outer panel { Top, 3 Bottom, 5 1/2	3
M.A.C., in.	83.3	84.3
L.E. of M.A.C. rearward of L.E. of root chord, in.	3.1	5.6
Ailerons:		
Chord, percent root chord	16.4	11.3
Area behind hinge line, sq ft	19.4	12.3
Span, percent b/2	36.8	40.5
Horizontal tail surfaces:		
Total area, sq ft	61.1	30.5
Span, ft	14.8	10.9
Elevator area behind hinge line, sq ft	28.1	12.0
Distance from c.g. to elevator hinge line, ft	16.8	16.2

TABLE I - Concluded

DIMENSIONS OF AIRPLANES REPRESENTED BY MODELS - Concluded

	Model A	Model B
Vertical tail surfaces:		
Total area, sq ft	25.8	14.4
Rudder area behind hinge line, sq ft	13.5	8.0
Distance from c.g. to rudder hinge line, ft	16.7	16.5
Maximum control settings:		
Rudder, deg	30 right, 30 left	30 right, 30 left
Elevators, deg	30 up, 20 down	35 up, 15 down
Ailerons, deg	30 up, 15 down	25 up, 10 down
Tail damping-power factor (calculated according to method of reference 8)	0.0000727	0.000175

NATIONAL ADVISORY
COMMITTEE FOR AERONAUTICS

TABLE II.- FULL-SCALE MASS DISTRIBUTION OF MODEL A FOR VARIOUS LOADING CONDITIONS TESTED

[Wing loading, 25 lb/sq ft; equivalent test altitude, 6000 ft; relative density $\frac{\rho}{\rho_0}$ at test altitude, 10.0]

Condition	Actual change from initial loading	Effective change from initial loading	I_x (slug-ft ²)	I_y (slug-ft ²)	I_z (slug-ft ²)	$\frac{k_x}{b/2}$	$\frac{k_y}{b/2}$	$\frac{k_z}{b/2}$	$\frac{k_x^2 - k_y^2}{b^2}$	$\frac{k_y^2 - k_z^2}{b^2}$	$\frac{k_z^2 - k_x^2}{b^2}$
*1	-----	-----	4,000	6,680	9,960	0.229	0.297	0.362	-88 × 10 ⁻⁴	-108 × 10 ⁻⁴	196 × 10 ⁻⁴
2	Mass extended along X-axis	(b)	4,000	12,520	15,800	.229	.405	.456	-280	-108	388
3	-----do-----	(b)	4,000	16,300	19,580	.229	.463	.507	-404	-108	512
4	Mass extended along Y- and Z-axes	Mass retracted along X-axis	13,480	11,590	14,870	.421	.390	.442	62	-108	46
5	Mass extended along X- and Z-axes	Mass retracted along Y-axis	7,270	13,230	13,230	.309	.418	.418	-196	0	196
6	Mass extended along Y-axis	(b)	8,960	6,680	14,920	.343	.297	.443	75	-270	196
7	-----do-----	(b)	12,140	6,680	18,100	.399	.297	.488	180	-375	196
8	Mass extended along Z-axis	(b)	7,280	9,960	9,960	.309	.362	.362	-88	0	88
9	-----do-----	(b)	9,960	12,640	9,960	.362	.408	.362	-88	88	0
10	Mass extended along X- and Y-axes	Mass retracted along Z-axis	6,965	9,645	15,900	.302	.356	.457	-88	-205	293
^c 11	Mass extended along Y- and Z-axes	(b)	12,640	12,640	12,640	.408	.408	.408	0	0	0
^d 12	Mass extended along Y- and Z-axes	Mass extended along Y-axis and retracted along X-axis	11,380	9,420	14,600	.387	.352	.438	64	-170	106
13	Mass extended along X-, Y-, and Z-axes	None	7,150	9,830	13,110	.307	.359	.415	-88	-108	196

*Initial loading condition (typical single-engine loading).

^bEffective change same as actual change listed in preceding column.

^cEqual moments of inertia.

^dTypical multiengine loading.

TABLE III.- FULL-SCALE MASS DISTRIBUTION OF MODEL B FOR VARIOUS LOADING CONDITIONS TESTED

[Wing loading, 27.3 lb/sq ft; equivalent test altitude, 8000 ft; relative density $\frac{m}{\rho S b}$ at test altitude, 13.0]

Condition	Actual change from initial loading	Effective change from initial loading	I_X (slug-ft ²)	I_Y (slug-ft ²)	I_Z (slug-ft ²)	$\frac{k_X}{b/2}$	$\frac{k_Y}{b/2}$	$\frac{k_Z}{b/2}$	$\frac{k_X^2 - k_Y^2}{b^2}$	$\frac{k_Y^2 - k_Z^2}{b^2}$	$\frac{k_Z^2 - k_X^2}{b^2}$
^a 1	-----	-----	3,050	5,250	7,850	0.225	0.295	0.360	-91×10^{-4}	-108×10^{-4}	199×10^{-4}
2	Mass extended along X-axis	(b)	3,050	10,500	13,100	.225	.418	.466	-309	-108	417
3	-----	-----	-----	-----	-----	-----	-----	-----	-----	-----	-----
4	Mass extended along Y- and Z-axes	Mass retracted along X-axis	12,650	10,980	13,580	.459	.426	.475	69	-108	39
5	Mass extended along X- and Z-axes	Mass retracted along Y-axis	5,650	10,450	10,450	.306	.416	.416	-199	0	199
6	Mass extended along Y-axis	(b)	6,940	5,250	11,740	.340	.295	.441	70	-269	199
7	-----do-----	(b)	9,520	5,250	14,320	.397	.295	.487	176	-375	199
8	Mass extended along Z-axis	(b)	5,650	7,850	7,850	.306	.360	.360	-91	0	91
9	-----do-----	(b)	6,750	8,950	7,850	.334	.385	.360	-91	46	45
10	Mass extended along X- and Y-axes	Mass retracted along Z-axis	4,520	6,720	10,790	.274	.335	.424	-91	-169	260
^c 11	Mass extended along Y- and Z-axes and retracted along X-axis	(b)	7,850	7,850	7,850	.360	.360	.360	0	0	0
^d 12	Mass extended along Y- and Z-axes and retracted along X-axis	Mass extended along Y-axis and retracted along X-axis	6,750	5,250	9,360	.334	.295	.394	62	-170	108
13	Mass extended along X-, Y-, and Z-axes	None	5,990	8,190	10,790	.314	.368	.424	-91	-108	199

^aInitial loading condition (typical single-engine loading).

^bEffective change same as actual change listed in preceding column.

^cEqual moments of inertia.

^dTypical multiengine loading.

NATIONAL ADVISORY
COMMITTEE FOR AERONAUTICS

CHART 1 - SPIN CHARACTERISTICS OF MODEL A

[Effect of mass variations along the X-axis; loading as indicated; cockpit closed; landing gear retracted; flaps neutral; recovery by full rapid rudder reversal; recovery attempted from and steady-spin data presented for rudder-with spins.; right erect spins]

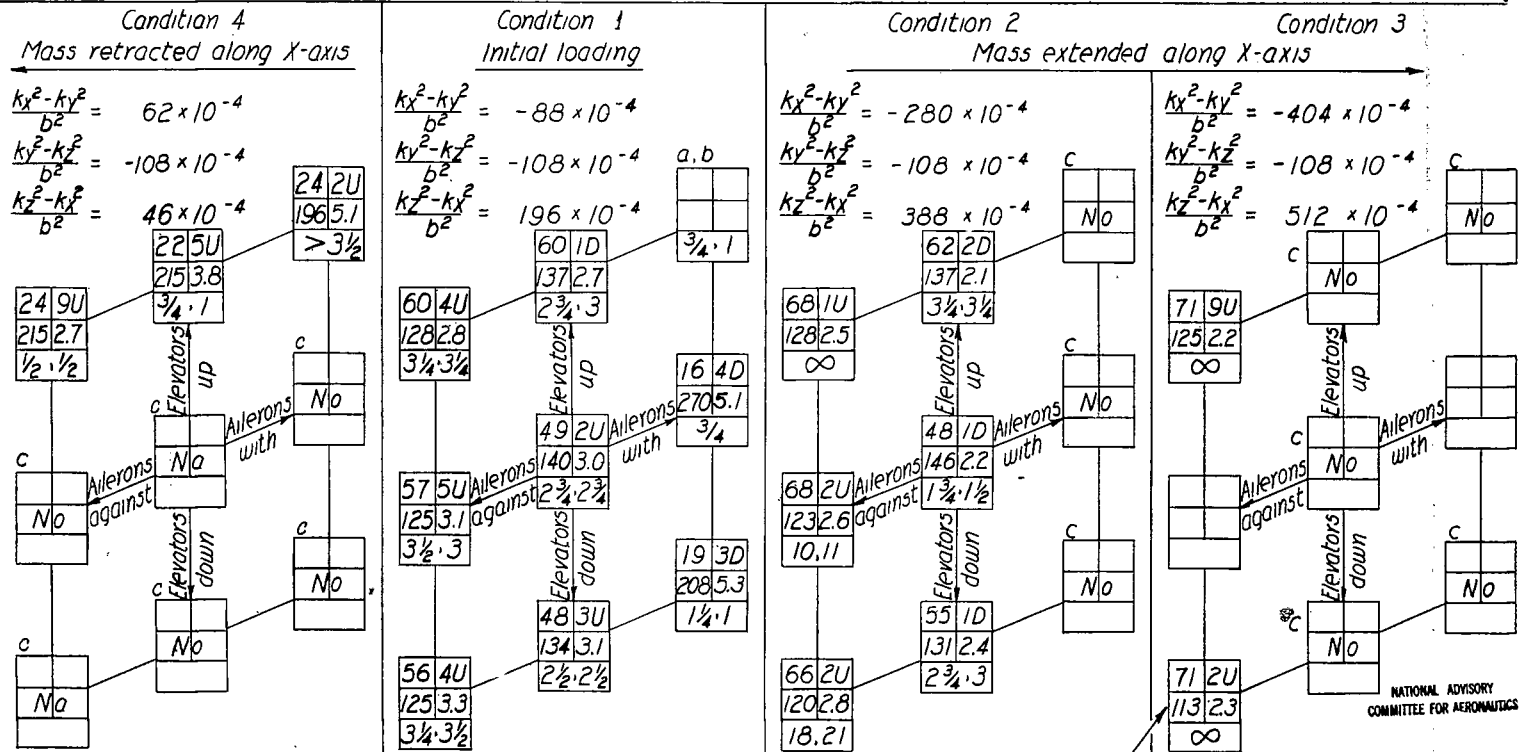

- a Wandering spin.
- b Oscillatory spin.
- c No means model would not spin.

Also spins jerkily. Fuselage appears to yaw to right about Z-axis in an attempt to become horizontal. As fuselage reaches horizontal, right wing reaches horizontal, right wing and nose drop. The cycle then repeats.

Model values converted to corresponding full-scale values.
 U denotes inner wing up,
 D, inner wing down

α (deg)	$\dot{\theta}$ (deg)
V (fps)	$\dot{\theta}$ (rad/sec)
Turns for recovery	

NATIONAL ADVISORY COMMITTEE FOR AERONAUTICS

CHART 1. - SPIN CHARACTERISTICS OF MODEL A - Continued

[Effect of mass variations along the Y-axis; loading as indicated; cockpit closed; landing gear retracted; flaps neutral; recovery by full rapid rudder reversal; recovery attempted from and steady-spin data presented for rudder-with spins; right erect spins]

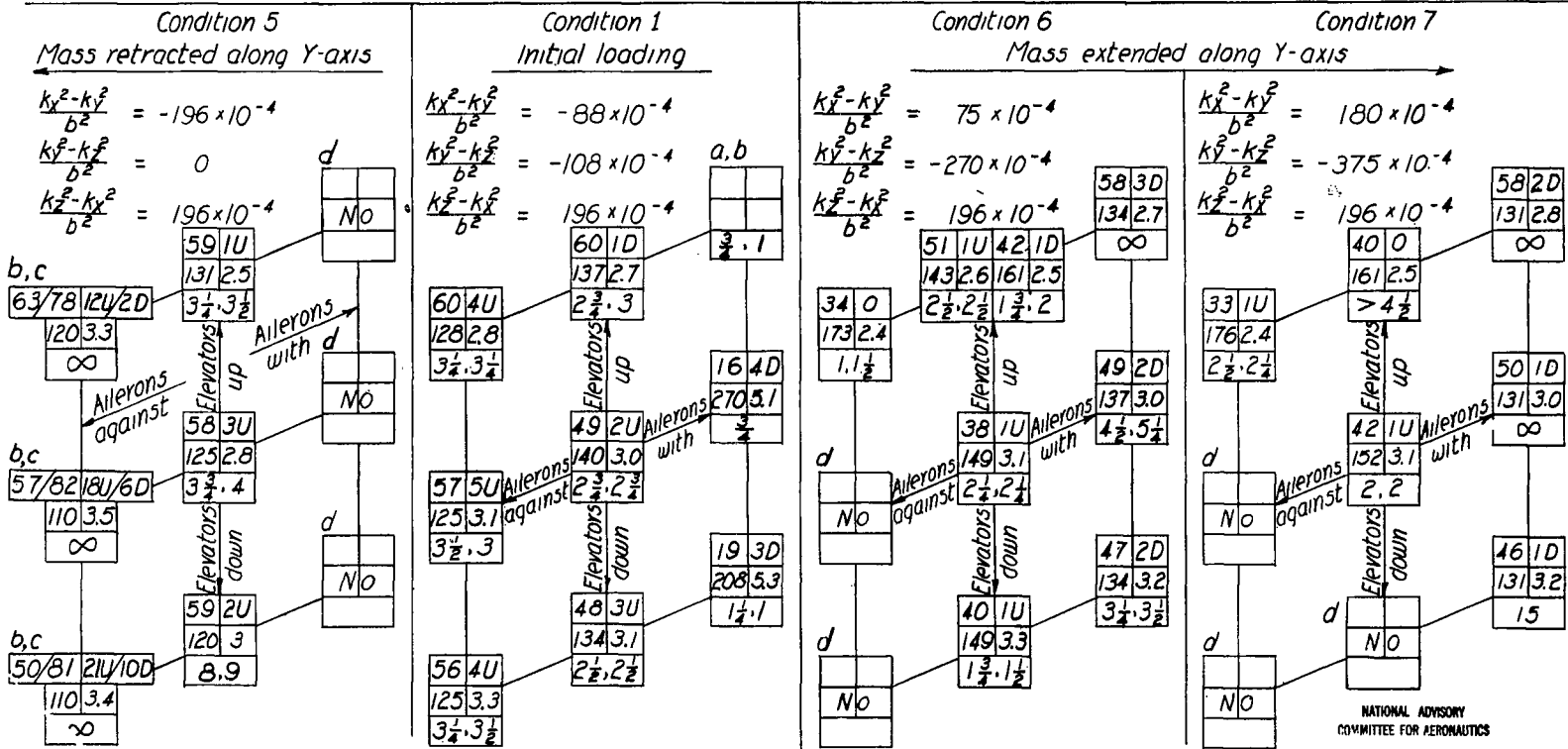

- a Wandering spin.
- b Oscillatory spin.
- c α and $\dot{\theta}$ vary between values indicated.
- d No means model would not spin.

Model values converted to corresponding full-scale values.
 α (deg) $\dot{\theta}$ (deg)
 V (fps) $\dot{\theta}$ (rad/sec)
 U denotes inner wing up; D, inner wing down.
 Turns for recovery

CHART 1. - SPIN CHARACTERISTICS OF MODEL A - Continued

[Effect of mass variations along the Z-axis; loading as indicated; cockpit closed; landing gear retracted; flaps neutral; recovery by full rapid rudder reversal; recovery attempted from and steady-spin data presented for rudder-with spins; right erect spins]

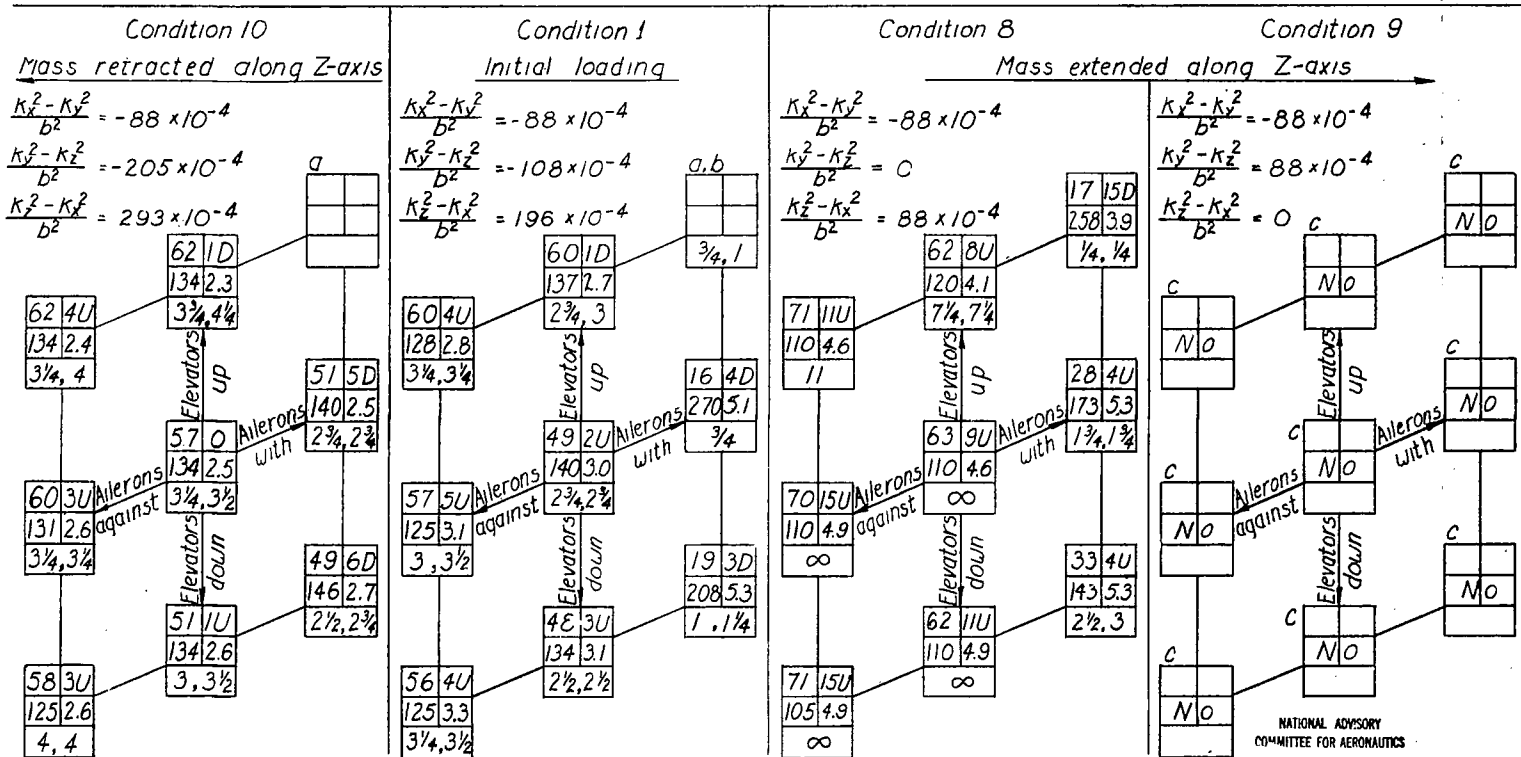

- a Wandering spin.
- b Oscillatory spin.
- c No means model would not spin.

Model values converted to corresponding full-scale values.
U denotes inner wing up; D, inner wing down.

α (deg)	θ (deg)
V (fps)	$\frac{rd}{sec}$
Turns for recovery	

NATIONAL ADVISORY COMMITTEE FOR AERONAUTICS

CHART 1.- SPIN CHARACTERISTICS OF MODEL A - Concluded

[Effect of special loading conditions; loading as indicated; cockpit closed; landing gear retracted; flaps neutral; recovery by full rapid rudder reversal; recovery attempted from and steady-spin data presented for rudder-with spin; right erect spins]

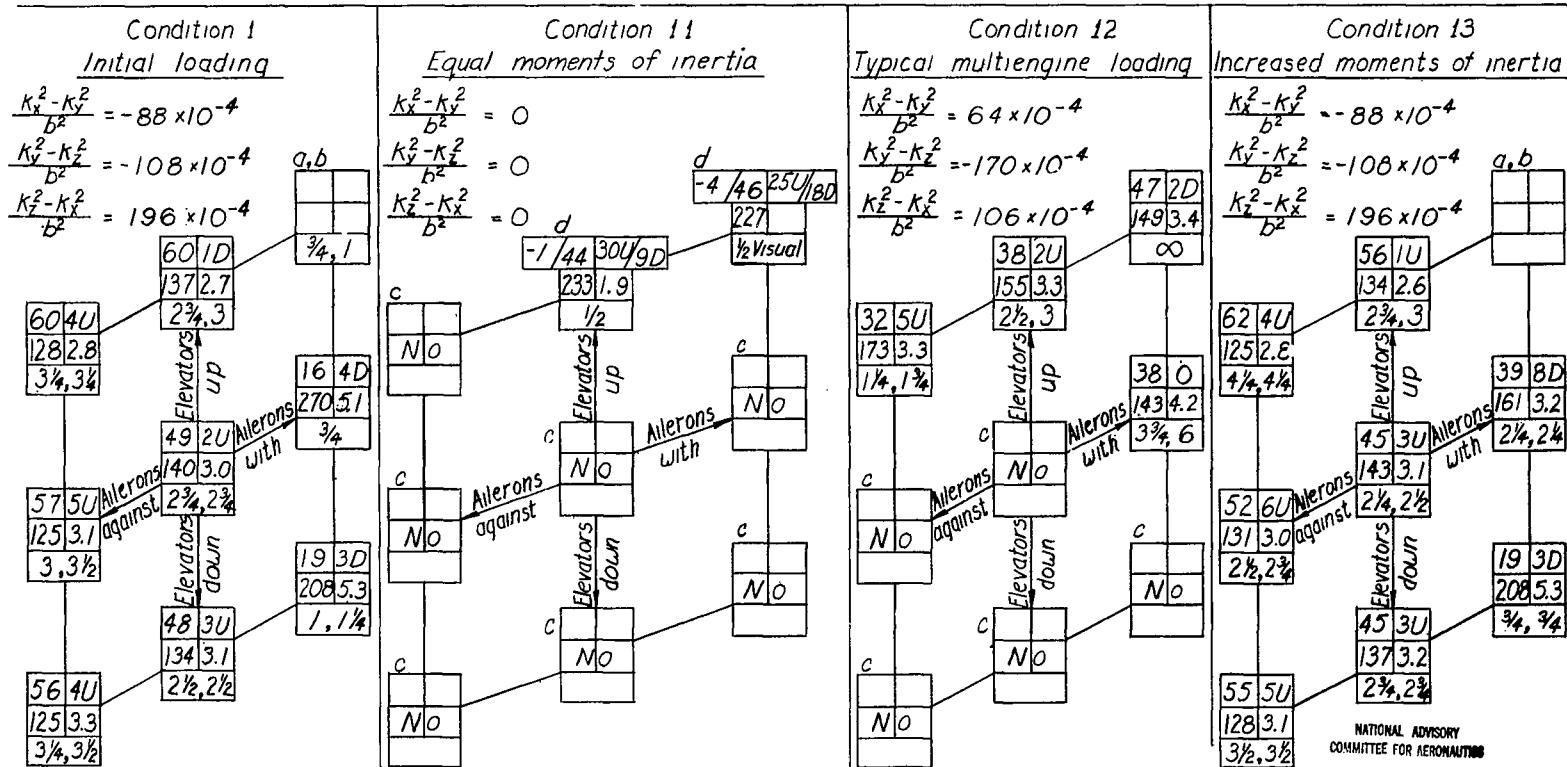

- a Wandering spin.
- b Oscillatory spin.
- c No means model would not spin.
- d α and θ vary between values indicated.

Model values converted to corresponding full-scale values.	α (deg)	θ (deg)
	(fps)	(rad/sec)
U denotes inner wing up; D, inner wing down.	Turns for recovery	

NATIONAL ADVISORY
COMMITTEE FOR AERONAUTICS

CHART 2.- SPIN CHARACTERISTICS OF MODEL B

[Effect of mass variations along the X-axis; loading as indicated; cockpit closed; landing gear retracted; flaps neutral; recovery by full rapid rudder reversal; recovery attempted from and steady-spin data presented for rudder-with spins; right erect spins]

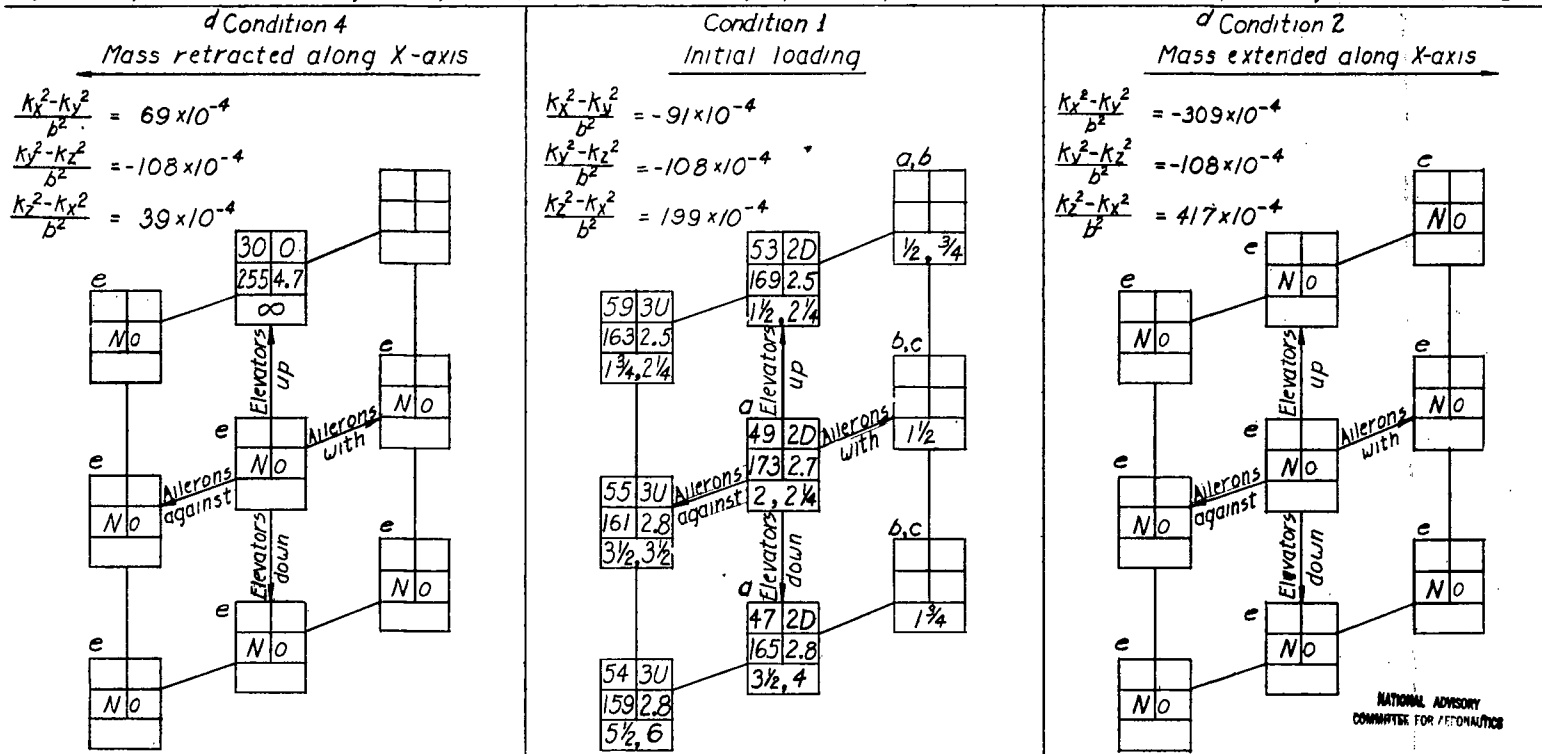

- a Wandering spin.
- b Recovery was attempted before model reached final attitude.
- c Steep spin.
- d Condition 3 was not tested for model B.
- e No means model would not spin.

Model values converted to corresponding full-scale values.
U denotes inner wing up, D, inner wing down.

α	θ
(deg)	(deg)
V	$\frac{\pi}{\text{rad}}$
(fps)	(rad/sec)

Turns for recovery

CHART 2. - SPIN CHARACTERISTICS OF MODEL B - Continued

[Effect of mass variations along the Y-axis; loading as indicated; cockpit closed; landing gear retracted; flaps neutral; recovery by full rapid rudder reversal; recovery attempted from and steady-spin data presented for rudder-with spins; right erect spins]

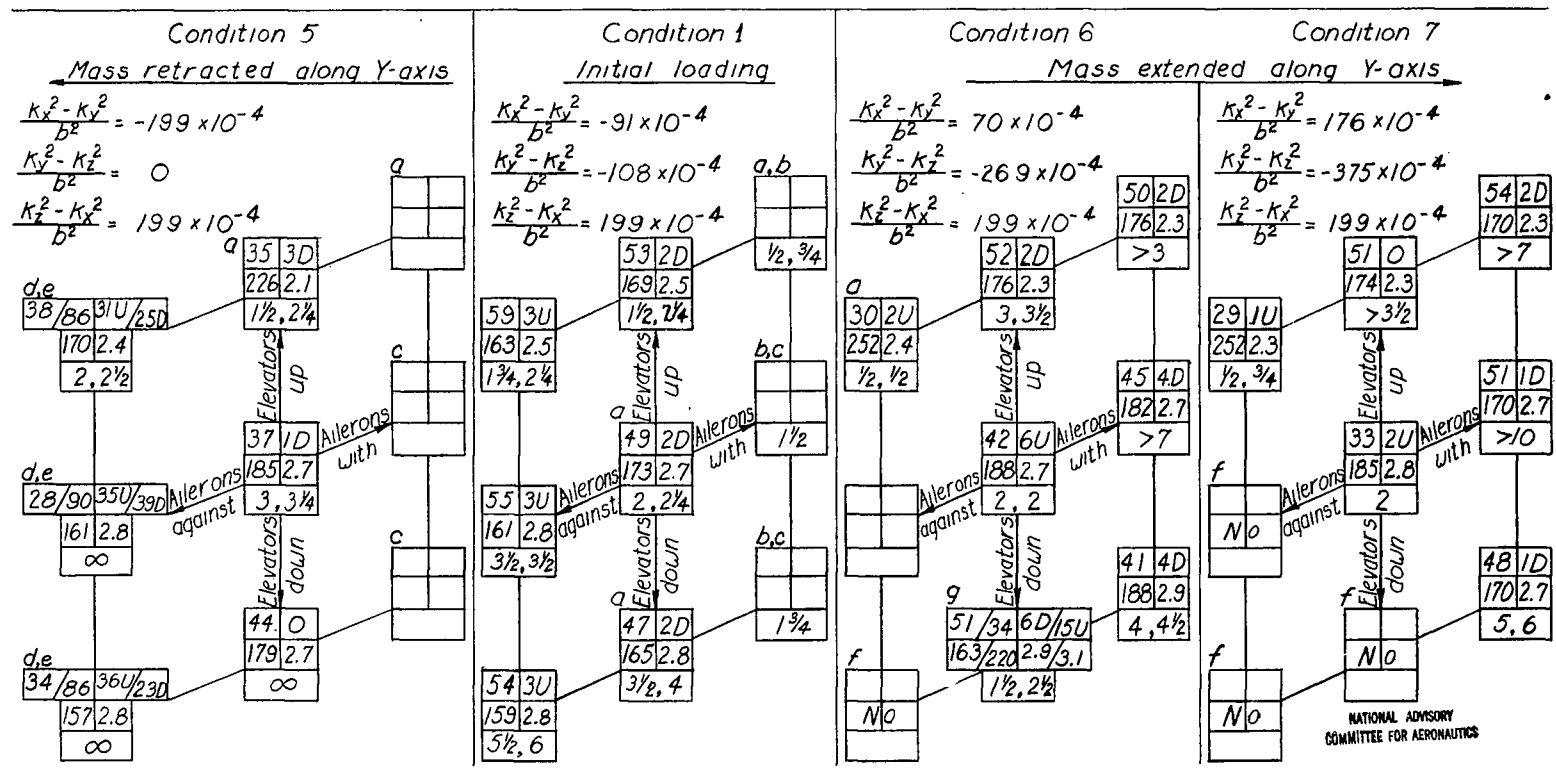

- a Wandering spin.
- b Recovery was attempted before model reached final attitude.
- c Steep spin.
- d Oscillatory spin.
- e α and ϕ vary between values indicated.
- f No means model would not spin.
- g Velocities and angles vary between values indicated.

Model values converted to corresponding full-scale values.
 U denotes inner wing up, D, inner wing down.

α (deg)	ϕ (deg)
V (fps)	$\dot{\phi}$ rad/sec
	Turns for recovery

NATIONAL ADVISORY COMMITTEE FOR AERONAUTICS

CHART 2. - SPIN CHARACTERISTICS OF MODEL B - Continued

[Effect of mass variations along the Z-axis; loading as indicated; cockpit closed; landing gear retracted; flaps neutral; recovery by full rapid rudder reversal; recovery attempted from and steady-spin data presented for rudder-with spins; right erect spins]

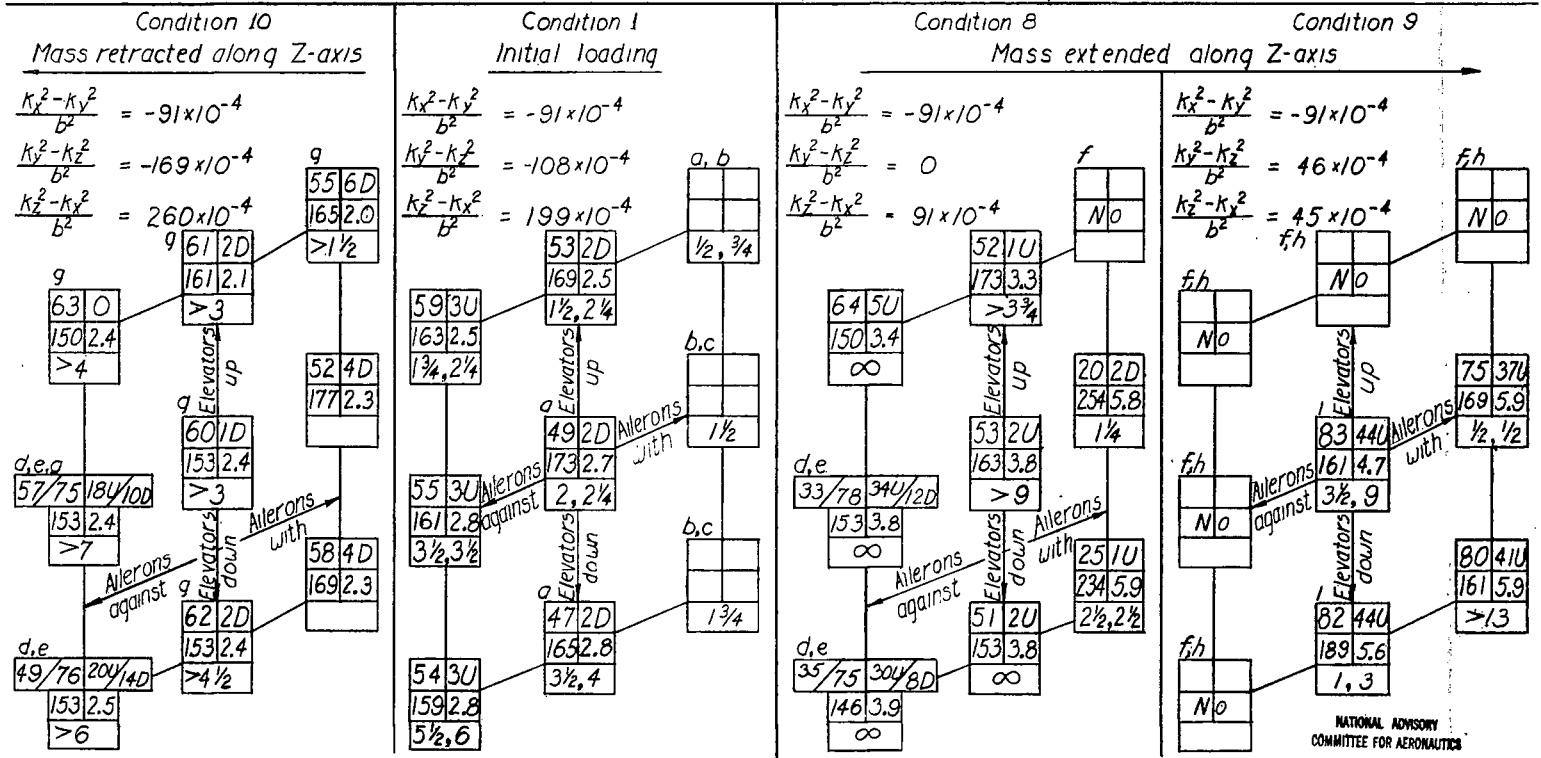

- a Wandering spin.
- b Recovery was attempted before model reached final attitude.
- c Steep spin.
- d Oscillatory in pitch and roll.
- e α and β vary between values indicated.
- f No means model would not spin.
- g On verge of recovery.
- h Model tumbled (rotated about lateral axis).
- i Model tumbled after recovery.

NATIONAL ADVISORY COMMITTEE FOR AERONAUTICS

Model values converted to corresponding full-scale values.	α (deg)	β (deg)
U denotes inner wing up,	ψ (ps)	θ (deg)
D, inner wing down.		Turns for recovery

CHART 2.- SPIN CHARACTERISTICS OF MODEL B- Concluded

[Effect of special loading conditions; loading as indicated; cockpit closed; landing gear retracted; flaps neutral; recovery by full rapid rudder reversal; recovery attempted from and steady-spin data presented for rudder-with spin ;right erect spins]

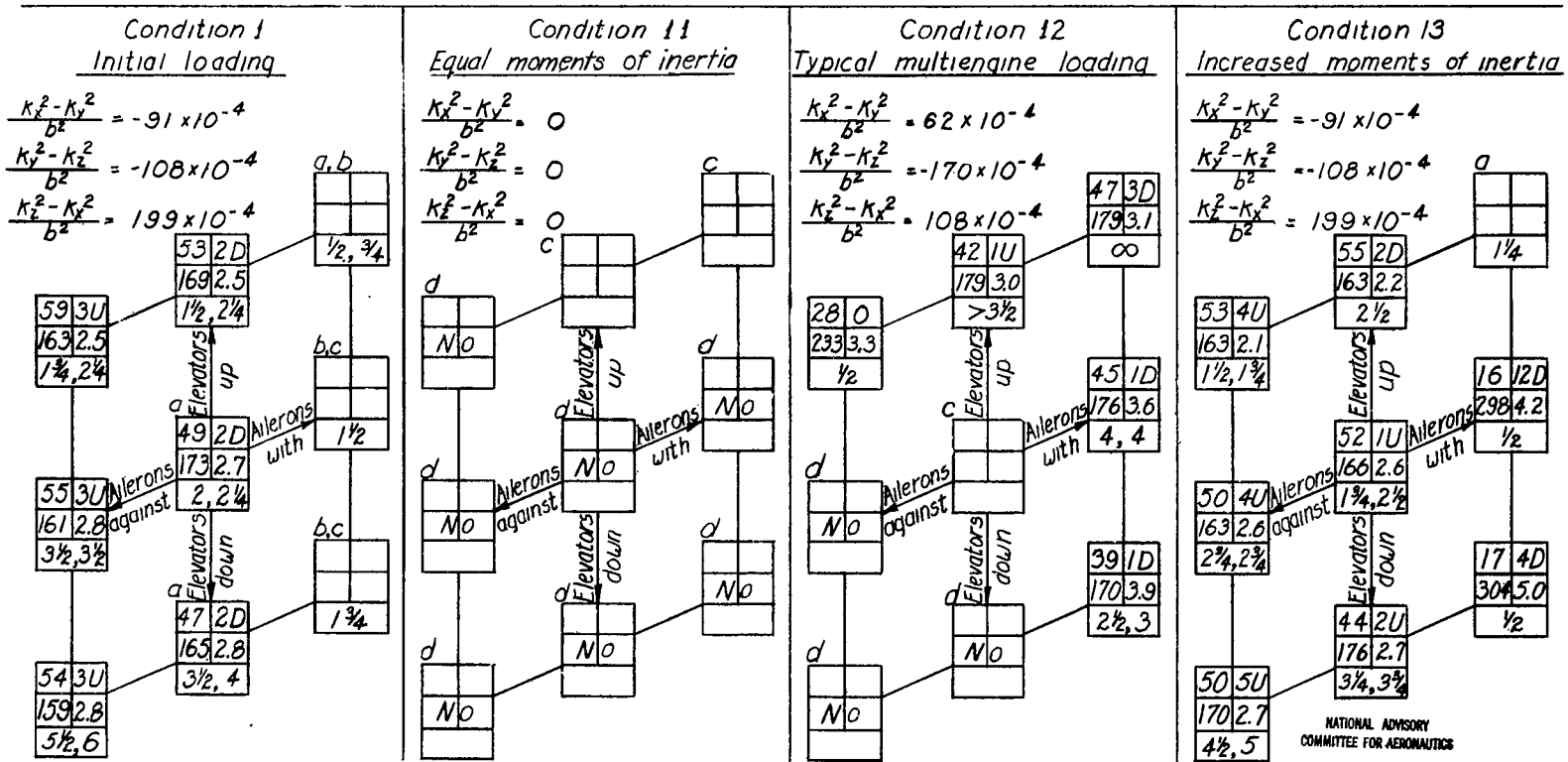

- a Wandering spin.
- b Recovery was attempted before model reached final attitude.
- c Steep spin.
- d No means model would not spin.

Model values converted to corresponding full-scale values.
 U denotes inner wing up; D, inner wing down.

α (deg)	β (deg)
V (fps)	$\dot{\psi}$ (rad/sec)
Turns for recovery	

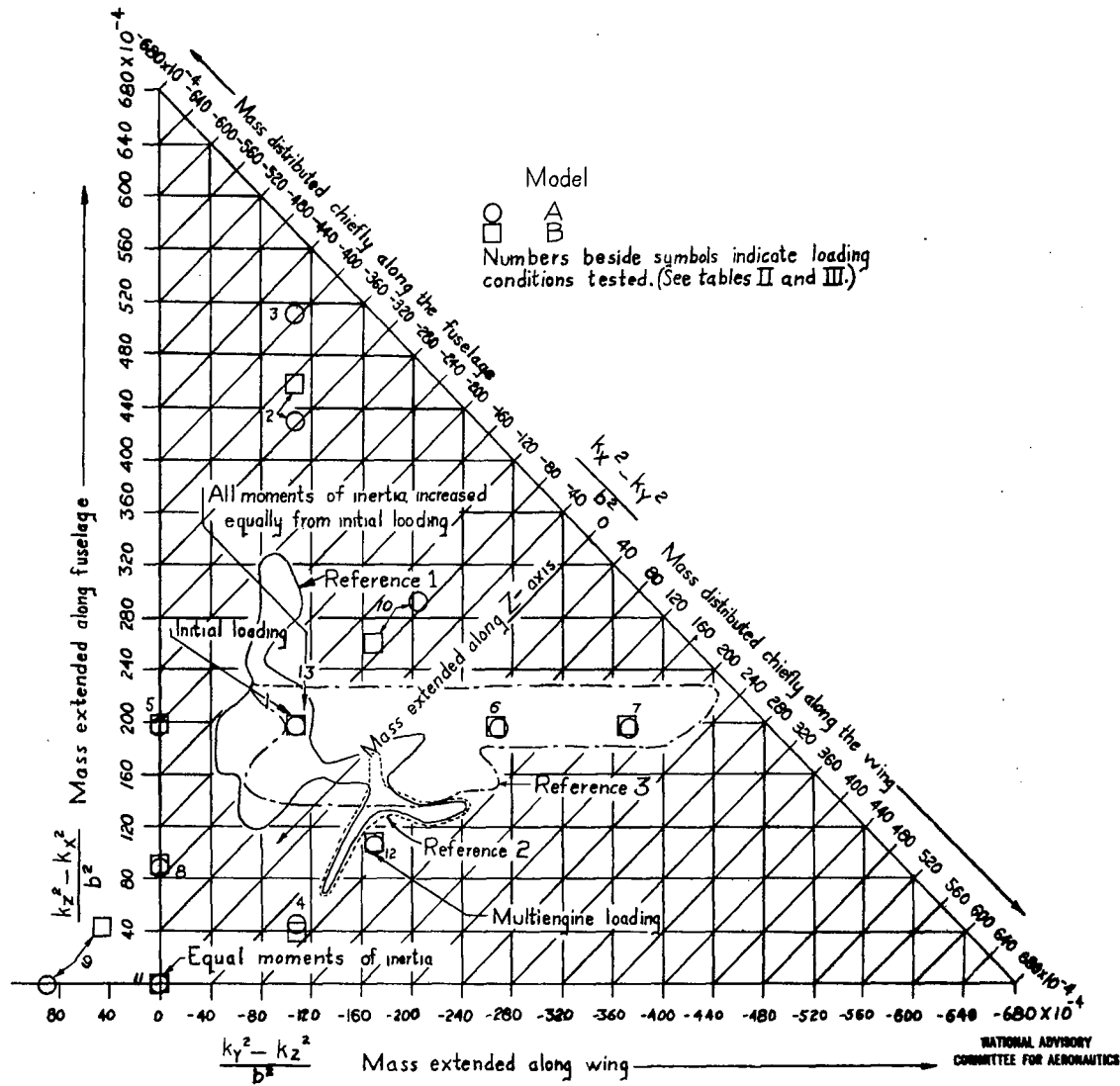
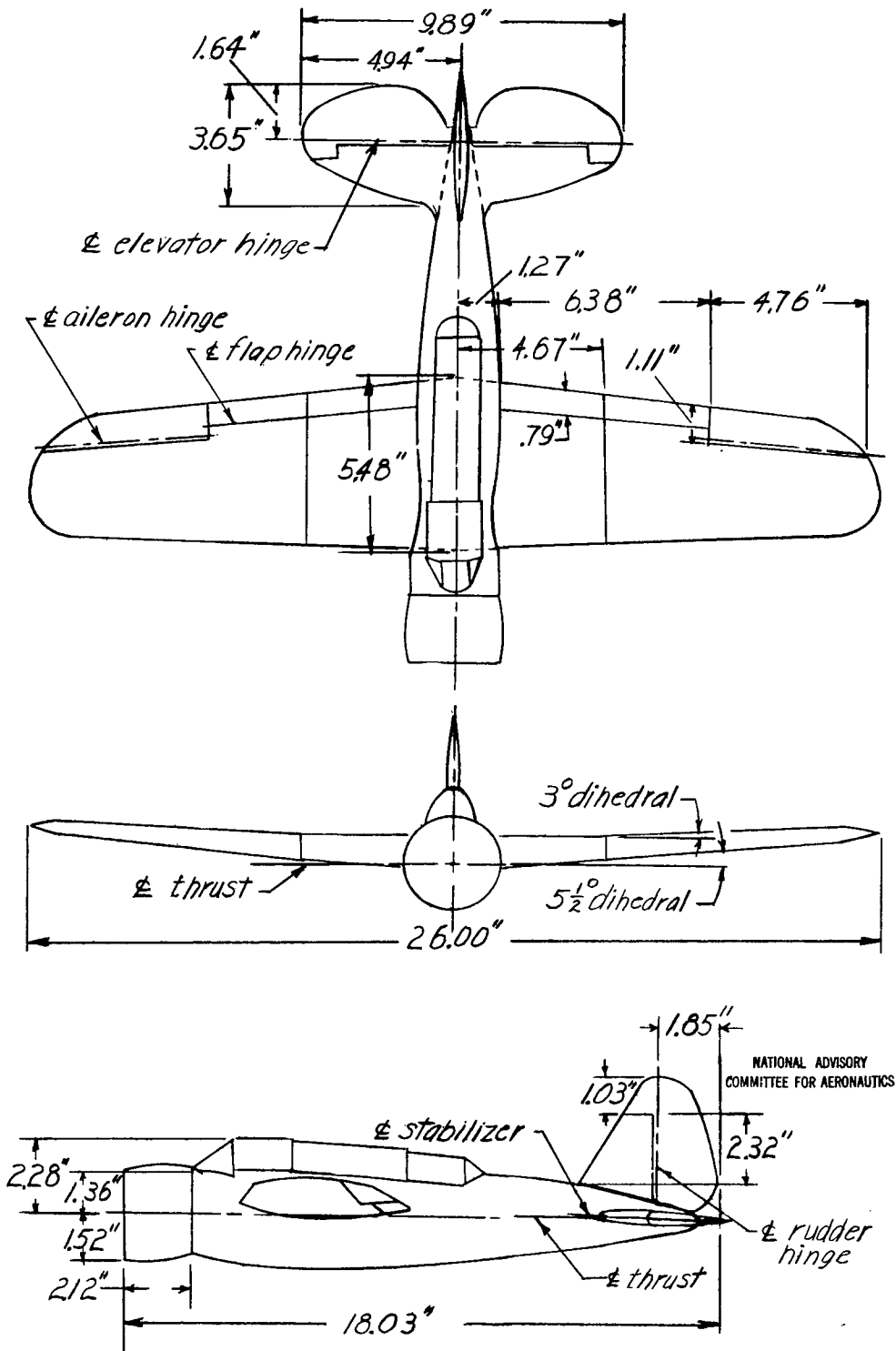

Figure 1.- Conditions tested with models A and B and ranges of inertia moment parameters for investigations described in references 1 to 3.



NATIONAL ADVISORY
COMMITTEE FOR AERONAUTICS

Figure 2.- The $\frac{1}{18}$ -scale model of airplane A as tested in the Langley 15-foot and 20-foot free-spinning tunnels.

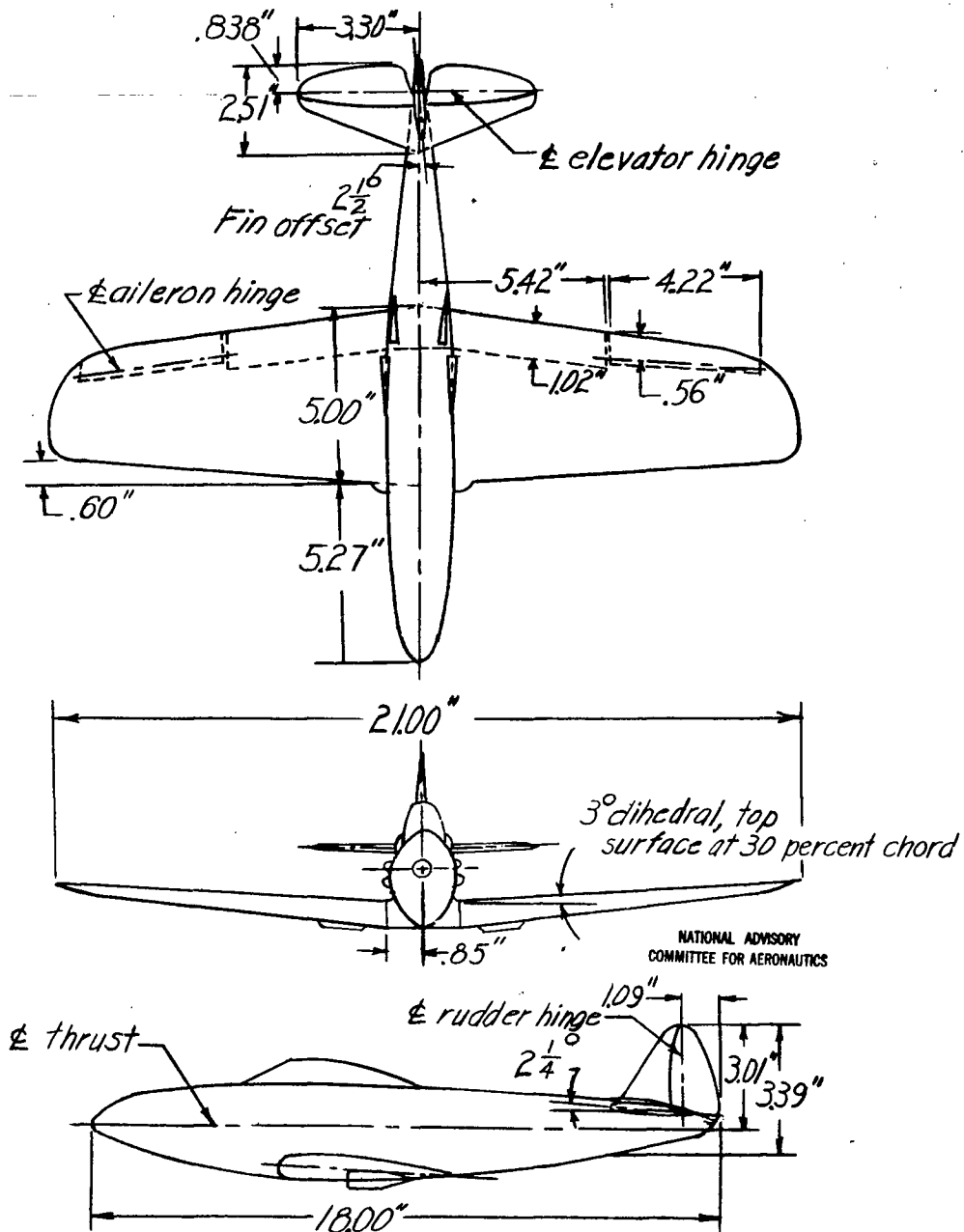

Figure 3.- The $\frac{1}{20}$ -scale model of airplane B as tested in the Langley 15-foot and 20-foot free-spinning tunnels.

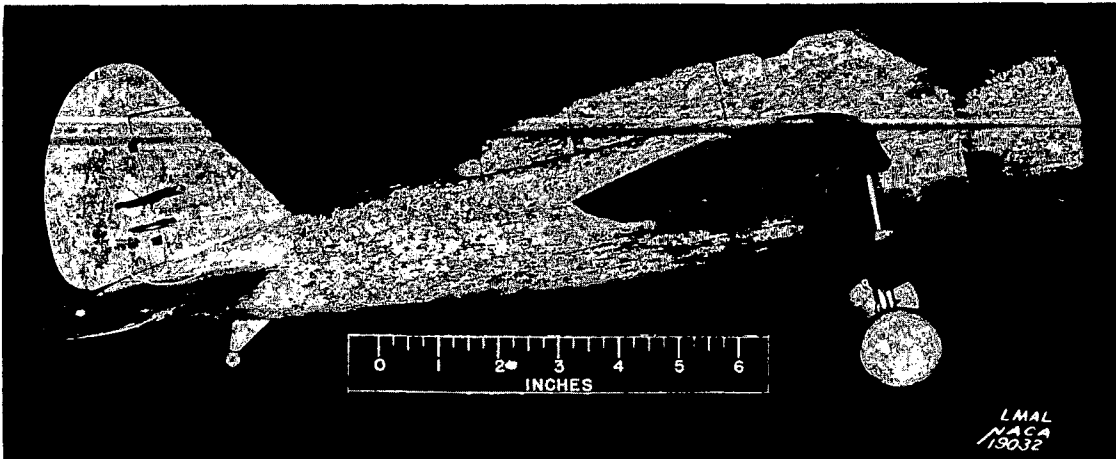

Figure 4.- Side view of model A.
Tests made with landing gear
retracted.

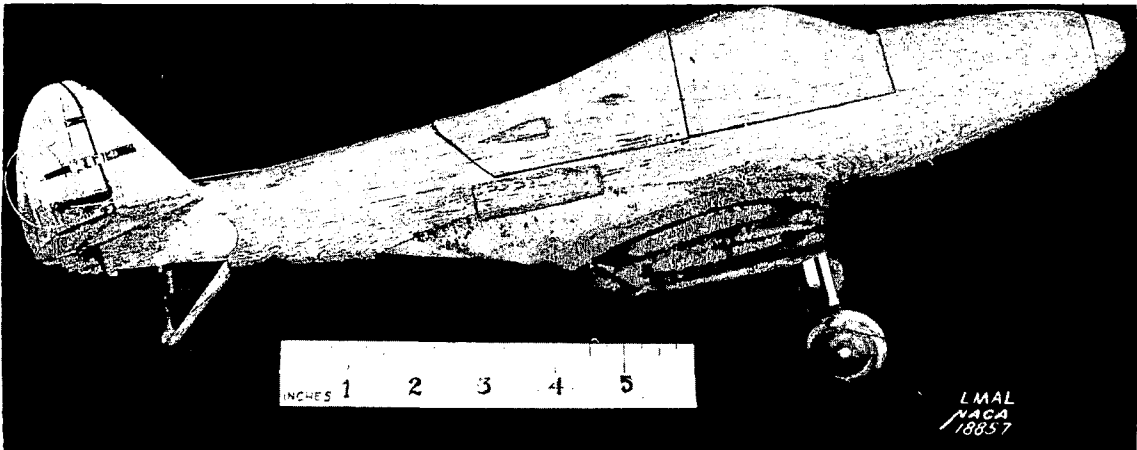

Figure 5.- Side view of model B.
Tests made with landing gear
retracted.

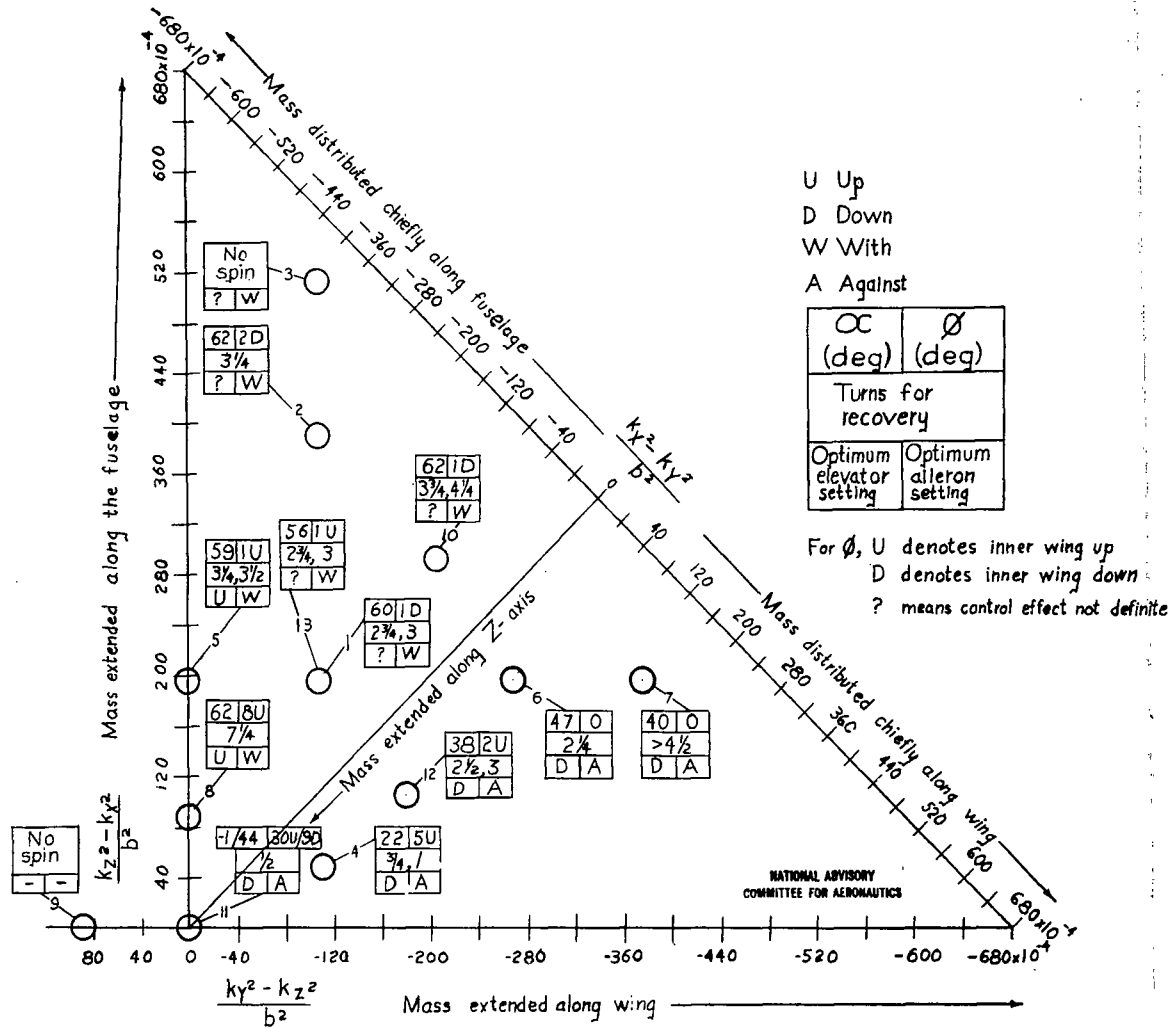

Figure 6.-A simplified presentation of the results obtained with model A. α , ϕ , and turns for recovery are given for the spin at the normal spinning control configuration (ailerons neutral, elevators up, rudder with).

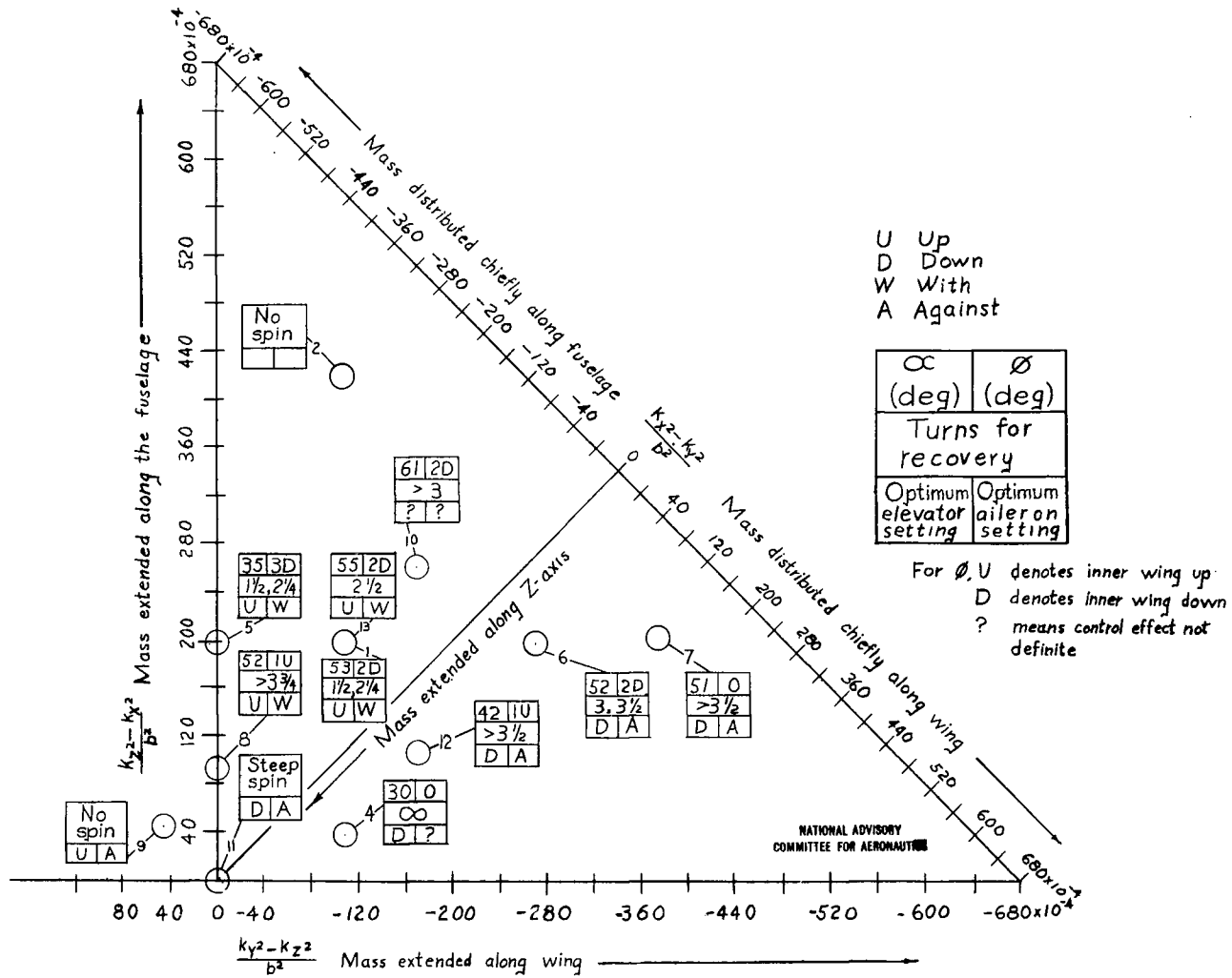

Figure 7.- A simplified presentation of the results obtained with model B. ∞ , \emptyset , and turns for recovery are given for the spin at the normal spinning control configuration (ailerons neutral, elevators up, rudder with).

TITLE: Spin-tunnel Tests of Airplane Models with Extreme Variations in Mass Distribution Along the Three Body Axes

AUTHOR(S): Kamm, Robert W.

ORIGINATING AGENCY: National Advisory Committee for Aeronautics, Washington, D. C.

PUBLISHED BY:

ATI- 7795

REVISION none

ORIG. AGENCY NO.
ARR-L5C09

PUBLISHING AGENCY NO.

DATE	DOC. CLASS.	COUNTRY	LANGUAGE	PAGES	ILLUSTRATIONS
March '45	Unclass.	U.S.	Eng.	33	photos, tables

ABSTRACT:

Two models of single engine airplanes of different design and aerodynamic characteristics were used with a series of different loadings in the investigation. Test results show the effects of the individual inertia moment parameters upon spin and recovery characteristics and the relative effectiveness of the various controls under different values of the three inertia moment parameters. Effect of these parameters on attitude, angular velocity, and steadiness of spin is also studied.

DISTRIBUTION: Request copies of this report only from Originating Agency

DIVISION: Aerodynamics (2)
SECTION: Stability and Control (1)

SUBJECT HEADINGS: Airplanes - Spin characteristics (084845); Airplanes - Spin recovery (08485)

ATI SHEET NO.: R-2-1-38

Air Documents Division, Intelligence Department
Air Materiel Command

AIR TECHNICAL INDEX

Wright-Patterson Air Force Base
Dayton, Ohio