

# NATIONAL ADVISORY COMMITTEE FOR AERONAUTICS

TECHNICAL NOTE

No. 1215

AN IMPROVED CONTINUOUS-INDICATING DEW-POINT METER

By Frank A. Friswold, Ralph D. Lewis  
and R. Clyde Wheeler, Jr.

Aircraft Engine Research Laboratory  
Cleveland, Ohio



Washington  
February 1947

# NATIONAL ADVISORY COMMITTEE FOR AERONAUTICS

## TECHNICAL NOTE NO. 1215

### AN IMPROVED CONTINUOUS-INDICATING DEW-POINT METER

By Frank A. Friswold, Ralph D. Lewis  
and R. Clyde Wheeler, Jr.

#### SUMMARY

A continuous-indicating dew-point meter that automatically maintains a mirror surface at the dew point has been developed. Heat conducted from the mirror to a coolant is balanced by heat generated at the mirror surface by radio-frequency induction heating. The heating is controlled by a photoelectric bridge circuit that detects the formation of dew on the mirror. This dew-point meter has two improvements over previously developed instruments of this type in that the use of induction heating greatly improves the stability and response to rapid variations in humidity and the photoelectric bridge circuit is one that renders the effect of ordinary variations in light intensity and operating voltage negligible.

The instrument was found to have an average accuracy of  $\pm 1^{\circ}$  F over the range of  $75^{\circ}$  to  $-45^{\circ}$  F. The error frequently exceeded the average for long periods in the range  $0^{\circ}$  to  $25^{\circ}$  F and for shorter periods at lower temperatures unless a special precaution was taken to assure indication of the vapor-solid rather than the vapor-liquid equilibrium temperature. This precaution was applicable only below  $15^{\circ}$  F, and there remains in the range  $15^{\circ}$  to  $32^{\circ}$  F an uncertainty in accuracy equal to the difference in the two possible equilibrium temperatures. The time to reach equilibrium after a sudden change in dew point was less than 3 seconds per  $^{\circ}$ F change.

A dew-point meter was used to measure the moisture content of air in the induction system of a military airplane during an investigation of ice formation in the induction system.

#### INTRODUCTION

In research on icing and de-icing characteristics of various aircraft and engine components, the moisture content of the air must be determined in order to evaluate results. If the dew point and total pressure of the air are measured, the moisture content may be calculated from fundamental gas laws.

A method of measuring dew points was devised by Regnault about 1845 and later modified by Alluard. This method requires the cooling of a mirror surface by evaporation of a volatile liquid, the observation of condensation upon the mirror surface, and the observation of the temperature of the mirror surface when the condensation appears. The performance of these operations is a tedious process and some practice is required to obtain accurate results. The observation of the first trace of dew upon the mirror is particularly difficult.

Continuous-indicating dew-point meters were developed by C. W. Thornthwaite and J. C. Owen of the Soil Conservation Service, U. S. Department of Agriculture about 1939 (reference 1) and by D. R. Storey of the National Research Laboratories of Canada about 1942 (references 2 and 3). In these continuous-indicating dew-point meters, the mirror is continuously cooled by a refrigerant whose temperature is well below the dew point and continuously heated by a resistor embedded beneath the mirror surface. Light from a lamp is reflected from the mirror surface to a photoelectric cell. Dew forming on the mirror causes a change in light intensity on the photoelectric cell. The appearance of dew is thus detected by the photoelectric cell, which energizes an electronic relay that increases the flow of heat to the mirror to hold its temperature at the dew point. The mirror temperature is measured by means of a thermocouple.

The instruments described in references 1, 2, and 3 have two disadvantages:

1. No method of compensation is provided for changes in intensity of the light source. The photoelectric cell is unable to distinguish a change in light intensity caused by dew from a change caused by voltage fluctuations or lamp aging. Extremely close lamp voltage regulation is required because the illumination varies as the third or higher power of the filament voltage.
2. Because heat originating in the resistor requires some time to reach the mirror surface, the surface may cool below the dew point and accumulate excessive dew before the surface temperature reaches the dew point. Inasmuch as the large quantity of dew cannot evaporate as soon as the mirror surface reaches the dew point, heat continues to flow from the resistor and causes the mirror temperature to overshoot the dew point. The mirror temperature may thus cycle about the dew point for a 5-minute period before equilibrium conditions are established, but this period of cycling is reduced by manually adjusting the current through the heating resistor in order to supply most of the heat required at equilibrium. The determination of a series of different dew points is, however, troublesome because a new

adjustment then becomes necessary for each substantial change in dew point. These disadvantages were overcome by a continuous-indicating dew-point meter developed at the NACA Cleveland laboratory. In this dew-point meter, a photoelectric bridge circuit is used that compensates for any changes in intensity of the light source. A high-frequency induction-heating system generates the necessary heat at the mirror surface and reduces the time required for the mirror temperature to reach equilibrium at the dew point.

An early model of the NACA dew-point meter was operated from a 28-volt direct-current source and utilized the change in diffused reflected light from the mirror to operate the photoelectric bridge. The present model is completely operated by alternating current and utilizes the specularly reflected light from the mirror to operate the bridge circuit.

This report describes in detail the present NACA dew-point meter, the results of calibration tests, and the application of the earlier meter to a flight investigation of ice formation in the induction system of a military airplane.

## DESCRIPTION OF INSTRUMENT

### Principle of Operation

A simplified schematic circuit diagram of the NACA dew-point meter is shown in figure 1. Light from the lamp is focused on mirrors 1 and 2 by means of lenses. The mirrors reflect the light beams to photoelectric cells 1 and 2, which are connected in series across a battery and form two arms of a bridge circuit. The battery is center-tapped to complete the bridge. The amount of light striking photoelectric cell 1 is adjusted by means of a shutter until an equal amount of light strikes each photoelectric cell. The bridge is now in balance and no voltage appears across points A and B.

Heat is conducted from mirror 2 by means of a copper rod immersed in a coolant. When the temperature of the mirror drops to the dew point, moisture condenses on the mirror surface and less light strikes photoelectric cell 2 than 1; the bridge becomes unbalanced. A voltage occurs across points A and B and is impressed upon the grid of the vacuum tube. The tube, in turn, causes high-frequency current to flow through the heater coil. The mirror surface is thus heated to the point where the moisture partly evaporates. The reflectivity of the mirror is partly restored and the bridge tends to return to balance. The moisture does not entirely evaporate, but an equilibrium point is reached where the reflectivity of the mirror is just sufficient to

maintain the mirror temperature at the dew point. The temperature of the mirror is measured by means of a thermocouple connected to a potentiometer or any other suitable indicating or recording instrument.

If no current is drawn from the bridge in a circuit of the type described and both photoelectric cells have identical characteristics it can be shown that the voltage  $e$  across A and B will be given by the equation

$$e = \frac{\frac{L_1}{L_2} - 1}{\frac{L_1}{L_2} + 1} E$$

where  $L_1$  and  $L_2$  are the light intensities on the two photoelectric cells and  $E$  is the total battery voltage. The output voltage therefore depends only upon the battery voltage and the ratio of light intensities. Any variation of light intensity at the lamp changes the light intensity on both photoelectric cells in the same proportion and therefore leaves the ratio of intensities at the cells unchanged. The voltage across A and B is therefore not affected by changes in light intensity at the source. This property of the bridge circuit serves to compensate for fluctuations in lamp intensity.

#### Complete Circuit

A complete circuit diagram of the NACA dew-point meter built to operate from the 115-volt, 60-cycle line is shown in figure 2.

When the circuit is being wired, the instantaneous polarities indicated by the + and - signs in figure 2 must be observed because alternating-current voltages are used throughout the circuit. The absence of a rectifier and a filter leads to simplicity in design of the direct-coupled amplifier. The circuit consists of the following three stages: (1) photoelectric cell bridge and coupling tube; (2) modulator stage; (3) oscillator stage.

The photoelectric cell bridge consists of two 925 photoelectric cells connected in series across a center-tapped transformer secondary. The output voltage of the bridge is impressed on the plate of a 6J5 triode, which is connected as a combined inverted triode and cathode follower and which offers very high impedance to the bridge circuit but has low output impedance. The current drawn from the bridge is therefore very small and consequently the effect of variation in light intensity at the source upon the output voltage of the

bridge is very slight. Experiments with the bridge showed that for a 50-percent change in lamp intensity the change in unbalance voltage is about 2 percent when the bridge is far from balance and negligible when the bridge is near balance.

A jack is provided in the cathode circuit of the 6J5 triode to permit insertion of a milliammeter to indicate bridge balance. If closing the normally open push-button switch in the bridge circuit produces no change in the milliammeter reading, the bridge is balanced.

The output voltage of the 6J5 triode is taken from the cathode and is applied to the control grid of the modulator tube. The modulator stage contains one 6AG7 vacuum tube, which is used as a high-gain amplifier for the output voltage of the 6J5. The grid bias is variable from 100 to 111 volts by means of a rheostat potentiometer. The bias may be manually increased to cut-off by the potentiometer, which permits maximum output of the oscillator and allows the bridge to be balanced when the instrument is in operation. The output of the 6AG7 is fed into the suppressor grid of the oscillator.

The oscillator stage contains one 802 vacuum tube in a conventional Hartley circuit. A fixed tank condenser is used of such capacity that the operating frequency is about 1 megacycle. The amplitude of oscillation is controlled by the potential of the suppressor grid. The screen grid of the tube receives its potential from a fixed source in series with a current-limiting resistor.

### Construction

The dew-point meter is assembled on a 14- by 10- by 3-inch base of 1/8-inch duralumin. A photograph of the instrument with cover removed is shown in figure 3. A cover of sheet metal is used to provide optical and electrical shielding, to protect the instrument from mechanical damage, and to protect the operating personnel from high voltage. (See fig. 4.) A hole in the top of the cover permits filling of the coolant box with dry ice, which is used to cool the mirror, without removal of the instrument cover. The arrangement of parts is shown in figure 5.

Figure 6 shows an enlarged section of a portion of the coolant box and accompanying parts. The coolant box consists of an inner copper box, which is thermally insulated by an outer double-walled box of pressed wood containing insulation between the walls. A 1/8-inch-diameter copper rod is pressed into a hole in the bottom of the copper box and extends through the front of the insulating box. This rod conducts heat away from the mirror.

The mirror is a 1/4-inch-diameter polished cap of 440 stainless steel pressed on the end of the copper rod. Several other metals were tried as mirror materials, but 440 stainless steel was judged to be the best of the rust-resisting materials tested because of its more rapid response to induction heating. The outside of the cap is threaded and fitted with a ring of heat-resistant plastic of 1/2-inch outside diameter. The ring extends from the outer wall of the coolant box to within one-sixteenth inch of the mirror surface. The induction heating coil is wound around the outside of this ring. The junction of a 36-gage iron-constantan thermocouple is placed about 0.005 inch below the mirror surface in a small hole drilled parallel to the mirror surface. The thermocouple leads terminate in a thermocouple connector located at the back of the chassis. A plastic block containing the dew chamber is clamped to the plastic ring; the joint is sealed by a pure gum rubber gasket.

The dew chamber is a cavity in the plastic block that forms a small compartment about the mirror surface. Two holes are drilled through opposite sides of the plastic block to the dew chamber to permit the passage of gas over the mirror. The gas sample is led to and from the dew chamber by plastic tubing connected to fittings in the back of the chassis. The two opposite sides of the plastic block not containing holes for gas passage are fitted with glass windows to permit a light beam to be reflected from the mirror surface to a photoelectric cell.

The optical system is shown in figure 5. The light source is a 25-candlepower, concentrated filament lamp. The filament of the lamp is focused on the mirror by lens 1. The light beam passes from the mirror at an angle of about  $12^\circ$  with the surface and is condensed by lens 2 onto photoelectric cell 2 so as to cover as much of the cathode as possible. Photoelectric cell 1 is illuminated by reflecting light to it through lens 3 by means of a glass mirror.

A screw (at right angles to the plane of the figure) in front of photoelectric cell 1 passes through a threaded hole in the chassis and is connected to a knob at one end of the chassis by a flexible shaft. This device serves as a variable aperture for balancing the photoelectric cell bridge.

## CALIBRATION AND OPERATION TESTS

### Calibration

Below  $32^\circ$  F, water vapor may exist in equilibrium with either ice or supercooled water. The temperature of supercooled water in equilibrium with vapor at any pressure is lower than the temperature

of ice in equilibrium with vapor at the same pressure. The equilibrium temperature for ice and vapor will be referred to as the "frost point." The equilibrium temperature for water and vapor will be referred to as the "dew point." These equilibrium temperatures obtained from reference 4 are shown in figure 7.

When the dew-point meter is in operation, the deposit on the mirror may be considered to exist in equilibrium with the water vapor in the gas passing over the mirror. The formation of super-cooled water on the mirror therefore results in a lower temperature indication than does the formation of ice.

Above 20° F, the NACA dew-point meter was calibrated by comparing its readings with the dew point or frost point of room air obtained with a wet- and dry-bulb psychrometer. Results of the calibration are shown in table 1.

TABLE 1. - CALIBRATION TESTS OF NACA

DEW-POINT METER ABOVE 20° F

Wet- and dry-bulb psychrometer		NACA dew-point meter
Dew point (°F)	Frost point (°F)	Indicated temperature (°F)
22	23	22
23	24	21
26	27	25
29	29	30
31	31	32
37	-----	38
38	-----	38
47	-----	49
48	-----	50
53	-----	54
55	-----	55
55	-----	56
71	-----	71
72	-----	72
73	-----	73
73	-----	74

A similar calibration below 20° F was impossible because air with dew points below 20° F was not readily available and because accurate determination of dew points by the wet- and dry-bulb method becomes increasingly difficult as dew-point temperatures decrease.

For example, at a dew point of  $-40^{\circ}$  F it would be necessary to measure wet- and dry-bulb temperatures with an accuracy of about  $0.01^{\circ}$  F in order to determine the dew point within  $1^{\circ}$  F. The dew-point meter was therefore calibrated in the range from  $10^{\circ}$  to  $-45^{\circ}$  F by means of a modification of the apparatus described in reference 5. Figure 8 is a schematic diagram of the calibration apparatus.

Air from a compressed-air source is filtered and then divided into two parts: one part passes in succession through a copper coil, a Milligan gas-washing bottle containing water, a bottle of wet sand, and a trap, all of which are contained in a water bath held at  $70^{\circ} \pm 1^{\circ}$  F. Walker and Ernst (reference 6) found that a similar arrangement produced air 93 to 96 percent saturated. The other part of the air is passed in succession through a drying tower containing silica gel, a trap cooled by dry ice and alcohol, and two drying towers containing activated alumina and anhydrous magnesium perchlorate, respectively.

The wet and dry air streams pass into separate pressure regulators, which control the pressure drop across two orifices. The two air streams emerging from these orifices are mixed to form the mixture used in calibration. The size of the orifices is varied to obtain required calibration points.

A portion of the mixture is drawn into a dry pump, which divides the mixture into two parts. One part is passed through the dew-point meter and the other through two absorption tubes containing anhydrous magnesium perchlorate and then through a wet-test gas meter.

The average vapor pressure of the mixture is calculated from the weight of water absorbed in the two absorption tubes and the total volume of air registered on the wet-test gas meter. The dew point and the frost point may be determined from the vapor pressure by the use of the tables given in references 4 and 6. It is advisable to have the weight of absorbed water as high as practical in order to obtain high accuracy in weighing. The mixture is pumped through the absorption tubes rather slowly (25 to 50 liters/hr) in order to insure complete absorption of the water. Practically all of the moisture is absorbed in the first tube.

The mixture from the calibration apparatus is pumped through the dew-point meter at a rate of 300 to 400 milliliters per minute. The pressure drop across the instrument is noted and one-half of this value is added to the mean barometric pressure during the run. The sum of these pressures is taken as the pressure at the mirror and is considered to be the total pressure in calculating the vapor pressure. A potentiometer-type pyrometer is used to record the temperature indicated by the dew-point meter for calibration.

The temperature is recorded for 2 to 6 hours, the time depending on the amount of moisture in the mixture. The temperature is then averaged over this time.

The constancy of the dew point of the mixture produced by this apparatus could only be judged by the record given by the dew-point meter. The maximum total variation that might be traced to variation in mixture composition during calibration at a point was 5° F at -45° F. At higher dew points, this maximum total variation was 3° F. The maximum variation in average dew points, determined gravimetrically, of mixtures produced on different days with the same orifices was 1.9° F.

Results of the calibration in the range 10° F to -45° F are shown in table 2. Two runs were made at each test condition. Calibration results from table 1 and table 2 are shown in figure 9.

TABLE 2. - CALIBRATION TESTS OF NACA DEW-POINT  
METER IN RANGE 10° F TO -45° F

Record	Dew point (°F)	Frost point (°F)	Mean recorded temperature (°F)
1	5.8	8.7	8.4
2	5.5	8.5	5.2
3	-2.6	.9	.2
4	-4.5	-.9	-1.2
5	-17.0	-12.3	-13.7
6	-17.4	-12.8	-13.8
7	-29.5	-24.0	-24.5
8	-29.8	-24.2	-24.7
9	-51.7	-45.5	-44.6
10	-53.3	-47.0	-46.3

Assuming the dew-point meter to indicate dew point above 32° F and frost point below, the average accuracy of the instrument is  $\pm 1^\circ$  F. Figure 9 shows errors exceeding the average accuracy occurring in the range 0° to 32° F. These errors may be explained by the fact that in this range supercooled water may frequently form on the mirror and remain for long periods without freezing. This water causes an indication of dew point rather than frost point. In the case of record 2 in table 2, the dew-point meter indicated dew point for 2 hours with a variation in the record of less than 1° F. In the other 9 records, the frost point was indicated. The instrument has

been observed to indicate dew points at temperatures as low as  $-30^{\circ}$  F in some cases for 15-minute periods before the indicated temperature rises to the frost point. During calibration these periods of dew-point indication below  $0^{\circ}$  F were of such short duration as to have little effect on the mean recorded temperature. In no case during calibration was any special precaution taken to insure indication of the frost point.

When the indicated temperature is between  $15^{\circ}$  and  $-40^{\circ}$  F, an indication of frost point is assured by closing the push-button switch in the bridge circuit, thus shutting off the induction heating, until the indicated temperature drops to  $-40^{\circ}$  F, and then opening the switch. The indicated temperature will then rise above the frost point, but will not rise to  $32^{\circ}$  F and will return to equilibrium at the frost point.

Frost-point indications are then assured by use of this technique unless the indicated temperature rises above  $32^{\circ}$  F or unless the frost point of the sample suddenly drops so low that the ice on the mirror is completely evaporated before the mirror temperature can drop to the new frost point. The complete evaporation of ice is evidenced by the current indication on the radio-frequency ammeter dropping to zero. In either case the procedure of closing the push button must be repeated in order to assure frost-point indication.

When indicated temperatures between  $15^{\circ}$  and  $32^{\circ}$  F are approached from above, no method of assuring frost-point indication has been devised. Allowing the indicated temperature to drop from that range to  $-40^{\circ}$  F causes an excessive deposit on the mirror. When the heat is released the mirror temperature rises above  $32^{\circ}$  F and the ice on the mirror melts. In the range  $15^{\circ}$  to  $32^{\circ}$  F, the accuracy is therefore uncertain by the amount of difference between the vapor-solid and vapor-liquid equilibrium temperatures. This difference is a maximum of  $2^{\circ}$  at  $15^{\circ}$  F.

#### Speed of Response

In order to check the speed of response, the following procedure was adopted: Air from a compressed-air source was passed through a drying tower and two tubes which bypassed the drying tower. The resulting mixture of dried and undried air was then passed through the dew-point meter. The dew point of the mixture could be suddenly changed by changing the flow of air through the bypass tubes. The average time required for the indicated temperature to come to equilibrium at the new value is given in table 3.

TABLE 3. - SPEED OF RESPONSE OF  
NACA DEW-POINT METER

Indicated temperature (°F)		Average time (sec)
From	To	
0	36	24
36	0	47
0	-10	14
-10	0	13
-10	-20	25
-20	-10	13
-20	-30	24
-30	-20	10
-30	-40	28
-40	-30	11
-40	0	25
0	-40	51

#### Effect of Change in Operating Voltage

The effect of a change in operating voltage was studied by operating the instrument from a variable transformer. Air was passed through the instrument to give an indicated temperature of 0° F and the operating voltage was varied between 100 and 135 volts. A sudden change in operating voltage upset the equilibrium and caused hunting; when equilibrium was regained, however, the total variation in indicated temperature was 1° F. After a sudden change in operating voltage of 5 volts, the average time for equilibrium to be recovered was 11 seconds.

#### APPLICATIONS OF DEW-POINT METER TO ICING RESEARCH IN FLIGHT

##### Induction System Icing

During an investigation of ice formation in the induction system of a military airplane conducted at the NACA Cleveland laboratory, it was necessary to know the moisture content of the air at three points in the induction system. An early model of the direct-current operated dew-point meter was used for this purpose. Tests were conducted on the ground and at altitudes up to 10,000 feet.

Figure 10 shows the dew-point meter installed in the airplane. A system was so arranged that a sample could be drawn through the dew-point meter from any one of the three stations where the moisture content was required.

During ground tests, the dew point of air entering the air scoop could be determined by means of a sling psychrometer. Agreement between these data and dew-point-meter readings was within about 2° F. When no free water was present, the moisture content of the air passing through the induction system did not change and a check on the precision of results could thus be obtained. The moisture content of samples from the three stations, as computed from dew-point-meter readings and pressure measurements, generally agreed within about 3 percent. This precision was considered to be adequate.

During the tests water spray was so introduced into the air scoop that the moisture content varied from station to station. It was found that the dew point at any sampling station could be determined in about 30 seconds. The range of dew points was 15° to 50° F.

#### Free-Water Content of Air

A method employing the dew-point meter was devised for obtaining the free-water content of air. A sample of the water-and-air mixture is collected by a heated scoop that vaporizes the free water, and the dew point of the resulting mixture is then measured. The dew point of the air alone is then obtained from a scoop that excludes free water. From the two dew points and the pressures in the dew chamber, the moisture content of the air may be calculated for each case. The difference in moisture contents is the amount of free water in the air.

An attempt was made to use this method in flight tests to determine the icing characteristics of the inlet screen of a jet-propulsion engine. It was found necessary, however, to differentiate more closely between moisture contents than the accuracy of the dew-point meter would permit.

#### GENERAL APPLICATIONS

The dew-point meter is of particular use in measuring extremely low humidity, or humidity at low temperatures, where other methods become slow and less reliable. In cases where humidity changes rapidly, the dew-point meter also should be useful in following the rapid fluctuations. The thermocouple output may be used to operate some alarm or control device for the purpose of humidity control.

Some care should be devoted to obtaining a true sample of air. When the sample is at a pressure below atmospheric, the sampling system must, of course, be free from leaks. Should the sampling line pass through regions where the ambient temperature is below the dew point of the sample, the line must be heated to avoid condensation in the line. The amount of rubber or plastic tubing used in the sampling line should be kept at a minimum because some of these materials absorb water at high humidities and then release it at low humidities. A flow of sample through the dew chamber should be maintained; otherwise, the moisture condensing on the mirror lowers the dew point of the sample so that a false reading is obtained. In calibration a flow of 300 to 400 milliliters per minute was found to be sufficient.

#### DISCUSSION

Although the dew-point meter has been successfully applied in some cases, it is still in the experimental stage. It is particularly desirable to prevent the formation of supercooled water on the mirror so that no manual manipulation of controls would be required to insure measurement of the frost point at temperatures below 32° F.

By a change of mechanical design, it should be possible to obtain sufficient cooling with dry ice to extend the lower operating limit. It is also entirely possible that the cooling could be done by mechanical refrigeration, although this method would involve a considerable increase in bulk. Modification of the mechanical design to facilitate observation and cleaning of the mirror surface is also desirable.

#### CONCLUSIONS

The dew-point meter developed by the NACA has two advantages over previously developed instruments of this type: (1) The use of the photoelectric-bridge circuit greatly reduces the effect of variation of light-source intensity and has made close regulation of the operating voltage unnecessary; (2) the use of induction heating improves the stability and response and thus increases the usefulness of the instrument. Laboratory and flight tests have shown that the use of induction heating permits measurement of rapidly changing dew points, which are varied by artificial means, as well as measurement of atmospheric dew points which usually vary slowly.

From records over long periods of time on air of fairly constant humidity, calibration data have been obtained that show an average accuracy of  $\pm 1^\circ$  F; but in the range 0° to 32° F, the error was frequently greater than average. This error was caused by supercooled

water forming on the mirror and remaining for long periods without freezing. Although below  $0^{\circ}$  F the probability of supercooled water remaining on the mirror for extended periods without freezing appears to be slight, the possibility of its forming at any temperature below  $32^{\circ}$  F is recognized. Therefore, unless precautionary measures are taken to insure the formation of ice on the mirror, the accuracy of the instrument below  $32^{\circ}$  F is uncertain by the difference in vapor-solid and vapor-liquid equilibrium temperatures. This uncertainty is especially noticeable when the equilibrium temperature is approached from above and observed only briefly. In the range  $15^{\circ}$  to  $32^{\circ}$  F, no method of assuring frost-point indications has been discovered. Thus, an accuracy of  $\pm 1^{\circ}$  F appears to be obtainable everywhere except in the range from  $15^{\circ}$  to  $25^{\circ}$  F.

Aircraft Engine Research Laboratory,  
National Advisory Committee for Aeronautics,  
Cleveland, Ohio, October 22, 1946.

#### REFERENCES

1. Thornthwaite, C. W., and Owen, J. C.: A Dew-Point Recorder for Measuring Atmospheric Moisture. *Monthly Weather Rev.*, vol. 68, no. 11, Nov. 1940, pp. 315-318.
2. Storey, D. R.: Preliminary Report on an Improved Dew-Point Hygrometer. Rep. No. MD-23, Nat. Res. Council of Canada, Sept. 3, 1942.
3. Storey, D. R.; An Improved Dew Point Hygrometer for Use at High Altitude. Rep. No. MD-28, Nat. Res. Council of Canada, Aug. 23, 1943.
4. Shields, C. D.: Mixtures of Air and Vapor at Temperatures Below Freezing. *Refrigerating Eng.*, vol. 38, no. 5, Nov. 1939, pp. 293-297.
5. Marvin, C. F.: Psychrometric Tables for Obtaining the Vapor Pressure, Relative Humidity, and Temperature of the Dew Point. W.B. No. 235, Weather Bur., U. S. Dept. Commerce, 1941.
6. Walker, A. C., and Ernst, E. J., Jr.: Preparation of Air of Known Humidity and Its Application to the Calibration of an Absolute-Humidity Recorder. *Ind. and Eng. Chem. (Anal. ed.)*, vol. 2, no. 2, April 15, 1930, pp. 134-138.

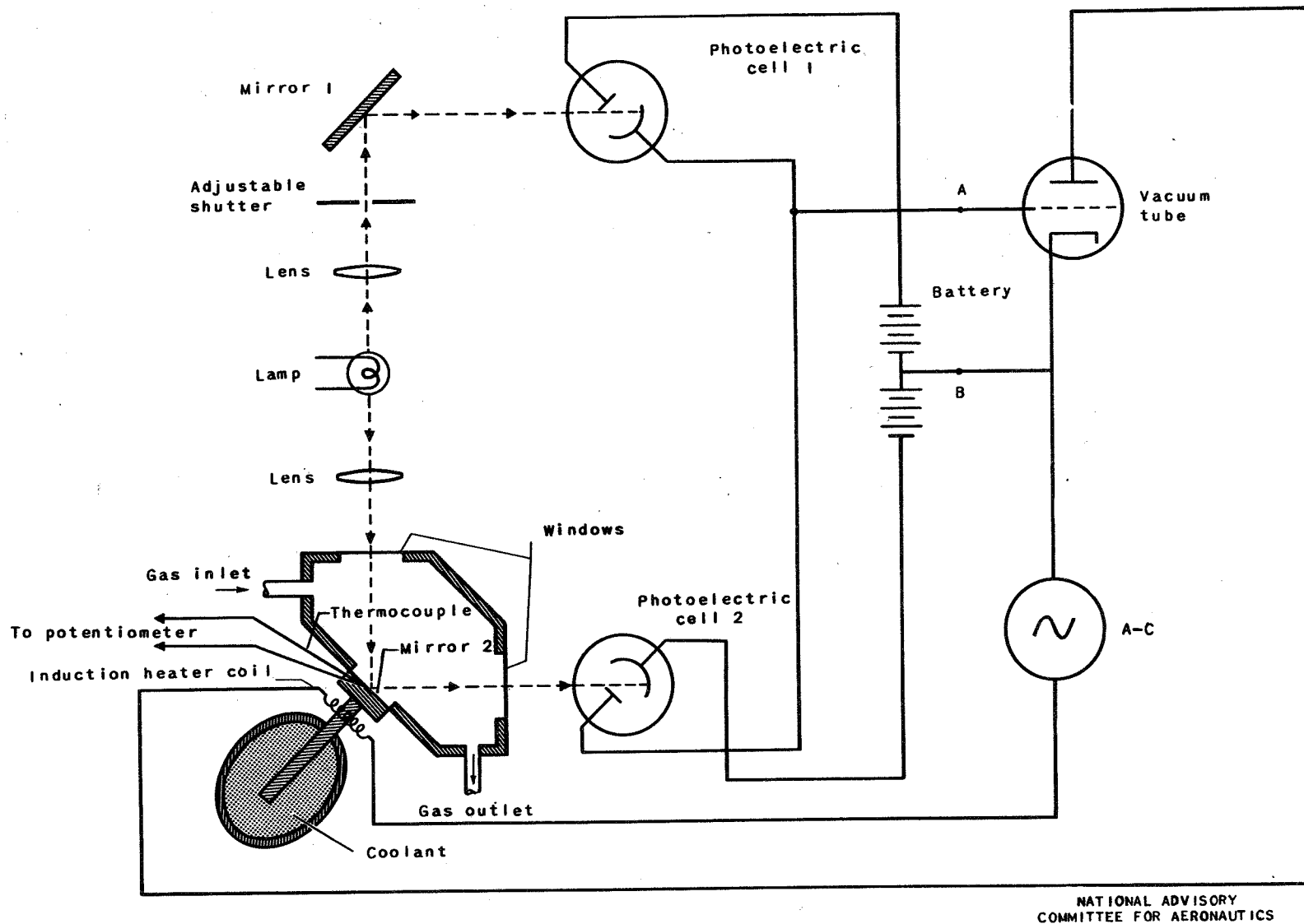

NATIONAL ADVISORY  
COMMITTEE FOR AERONAUTICS

Figure 1. - Simplified schematic diagram of NACA dew-point meter circuit.



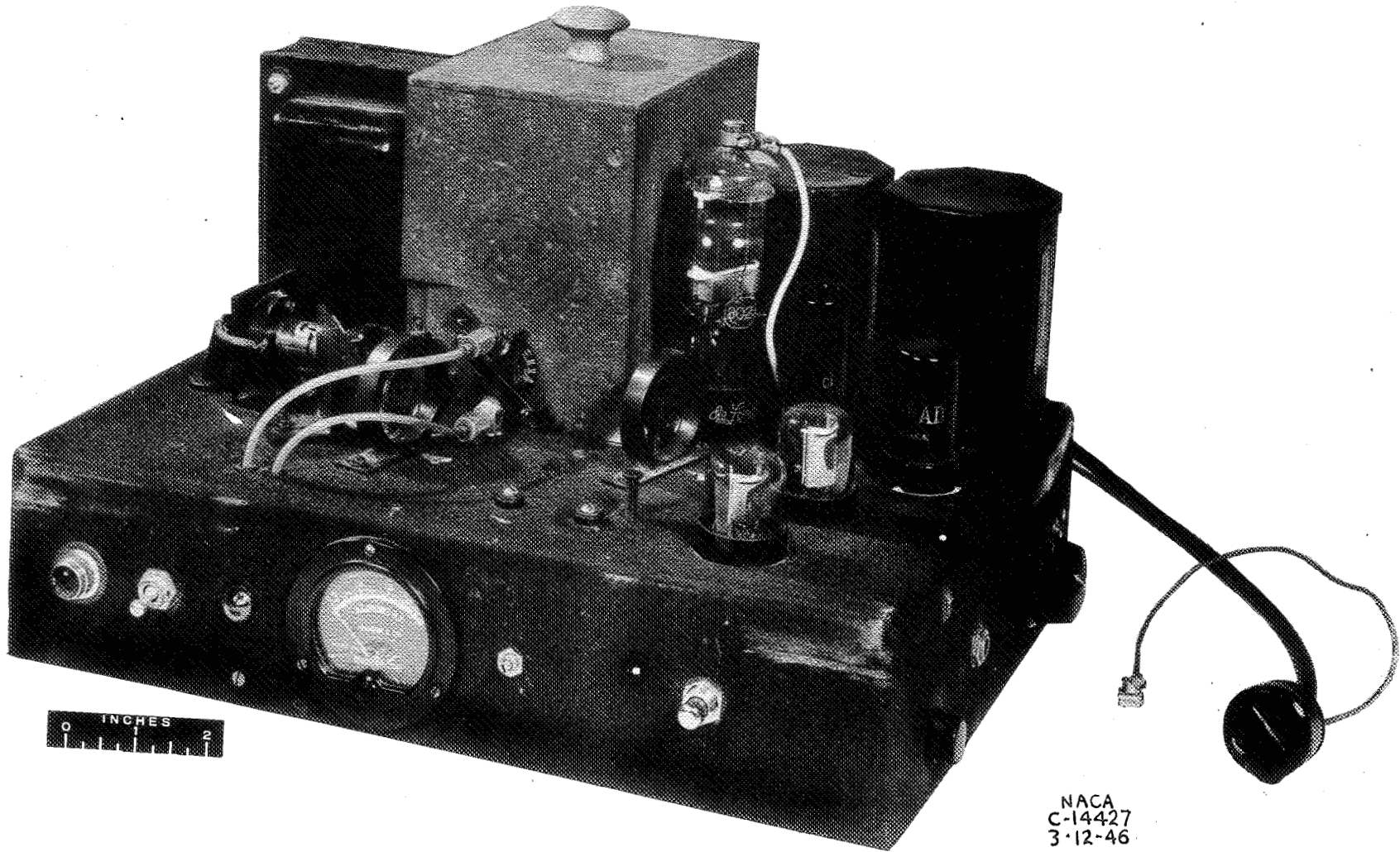
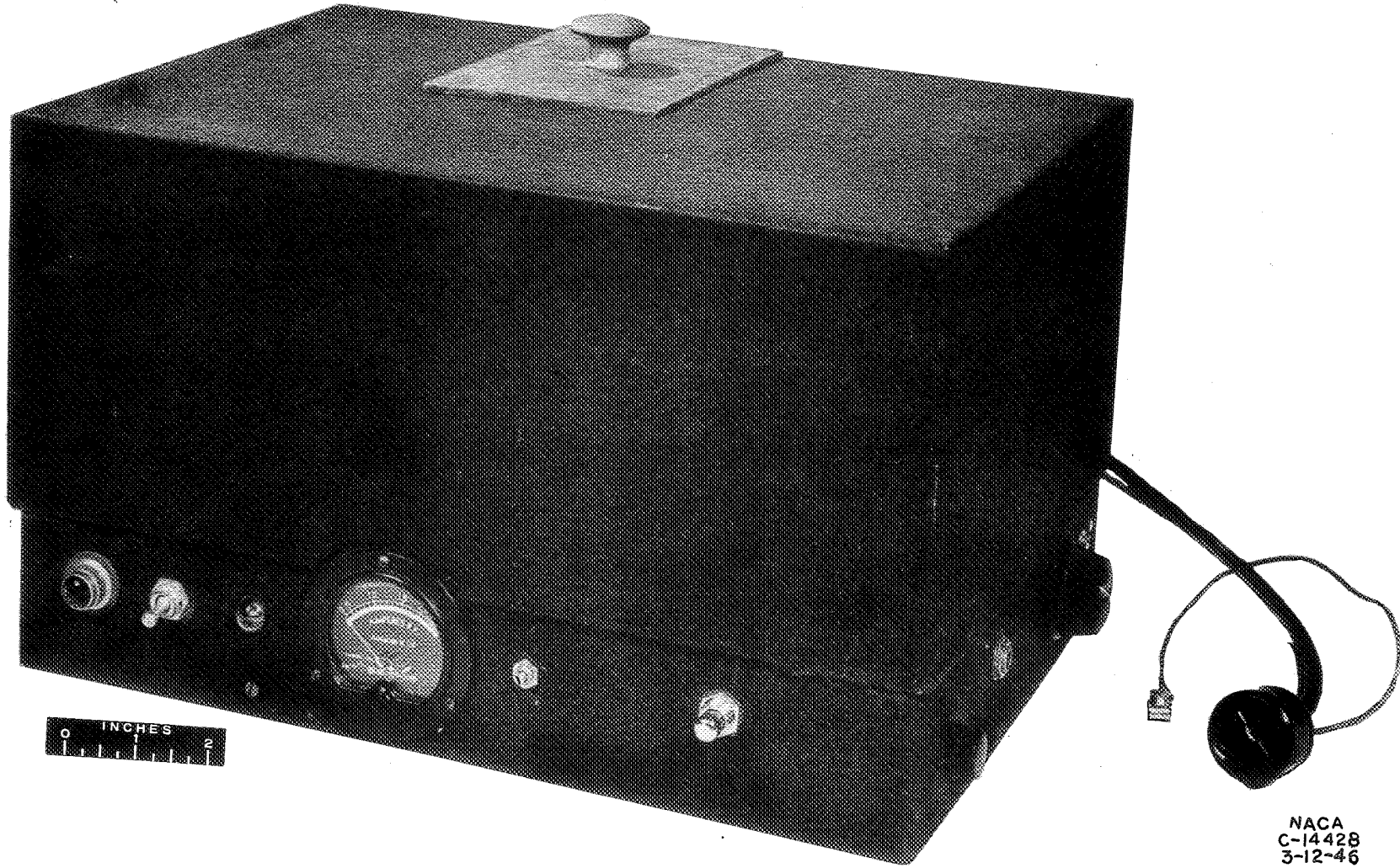

Figure 3. - NACA dew-point meter for 115-volt alternating-current operation.



NACA  
C-14428  
3-12-46

Fig. 4

Figure 4. - NACA dew-point meter for 115-volt alternating-current operation with cover in place.

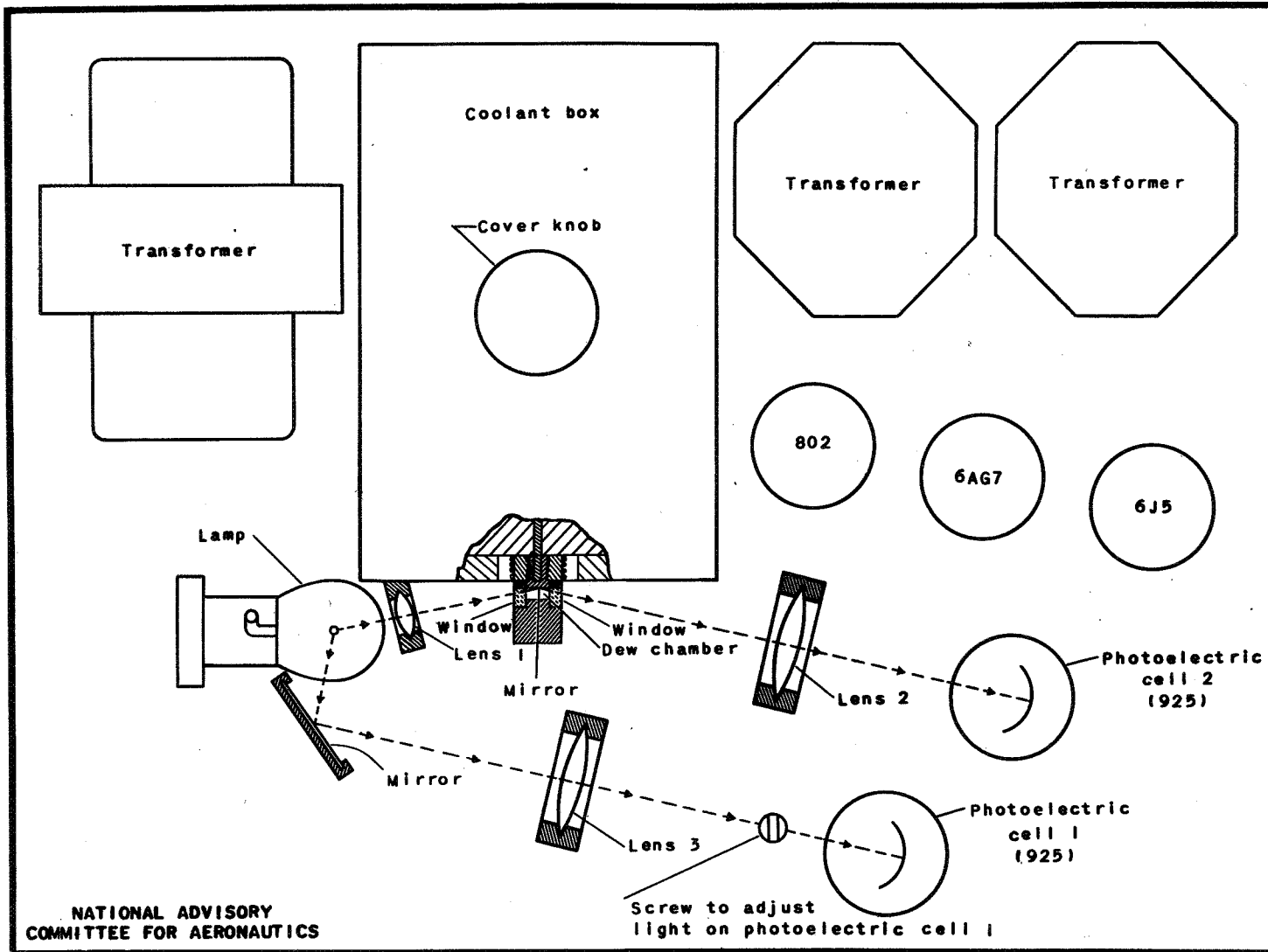
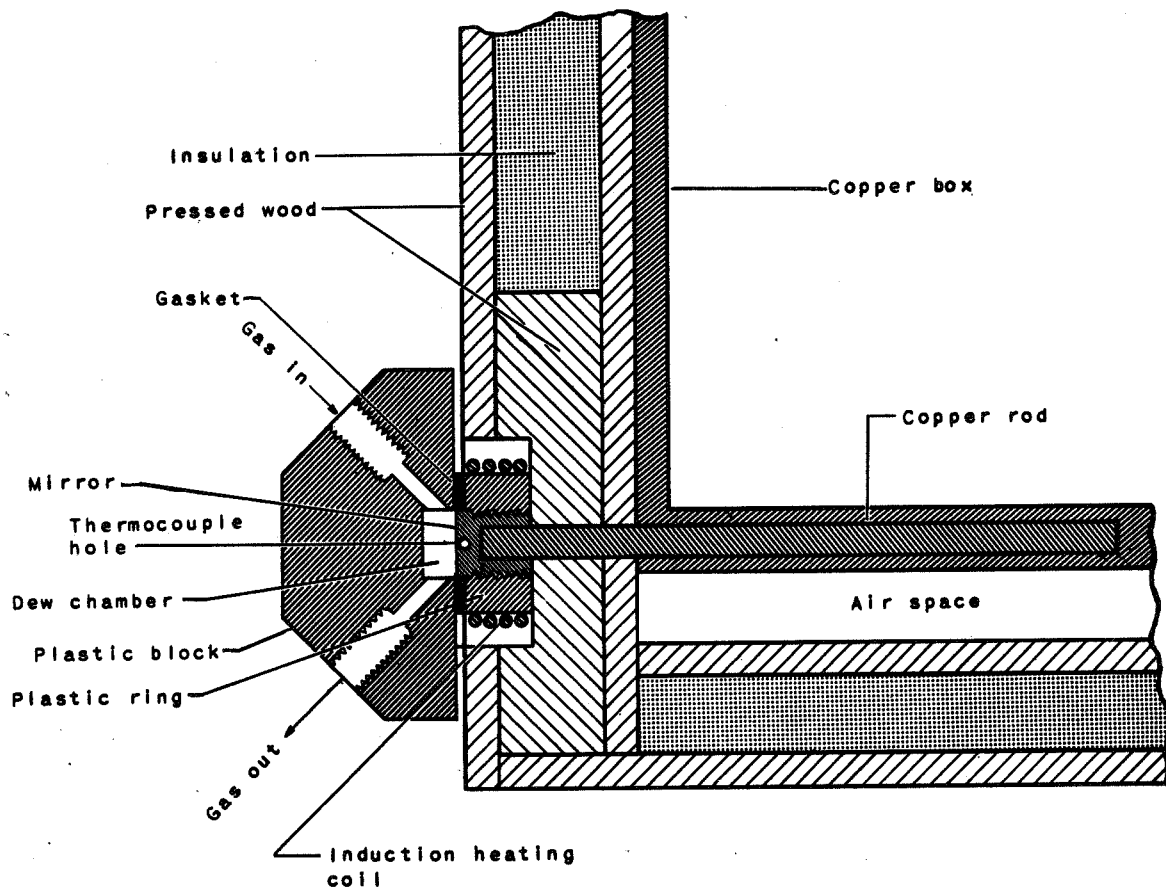

Figure 5. - Arrangement of parts for NACA dew-point meter.



NATIONAL ADVISORY  
COMMITTEE FOR AERONAUTICS

Figure 6. - Enlarged section of a portion of coolant box and accompanying parts.

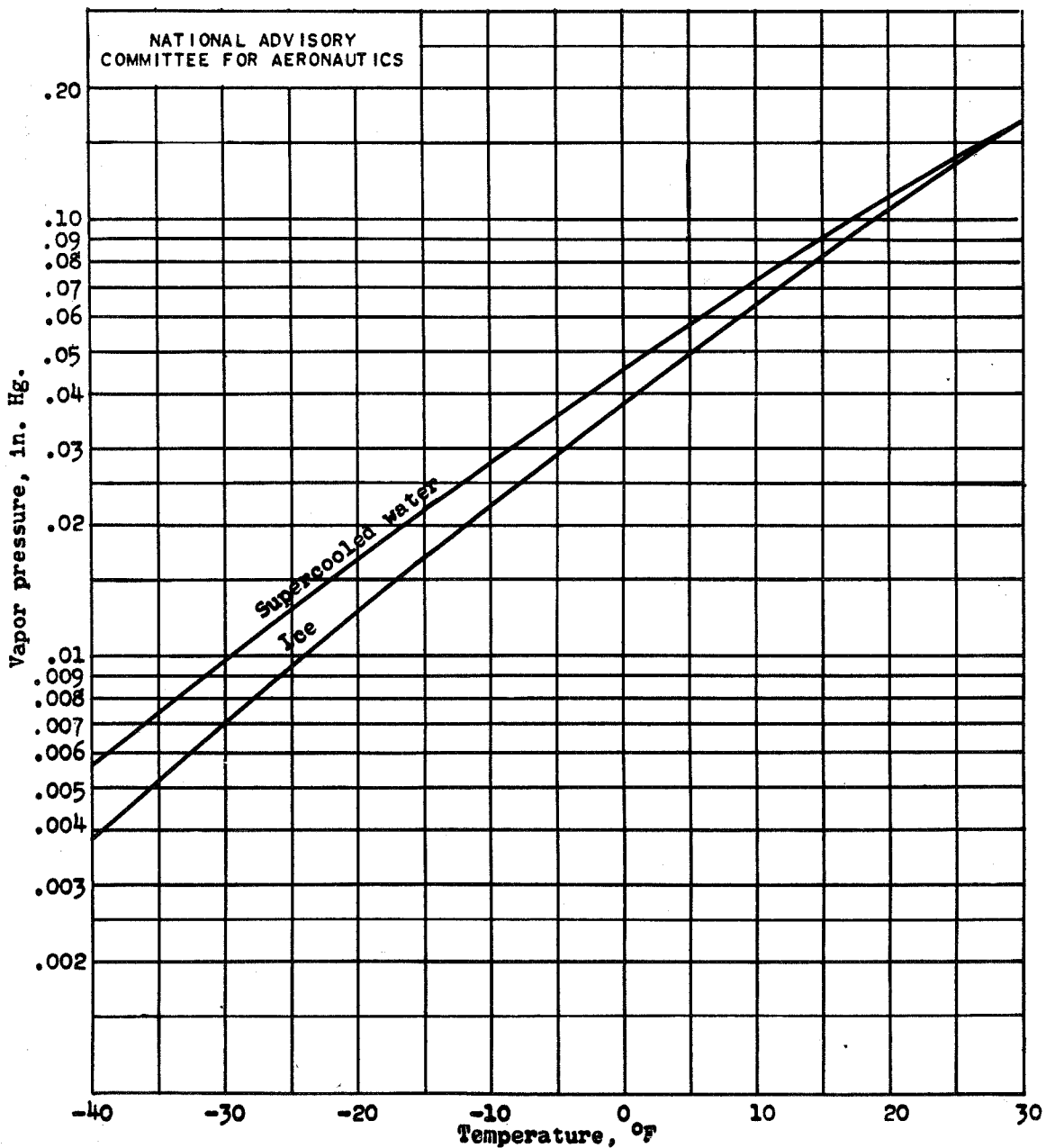
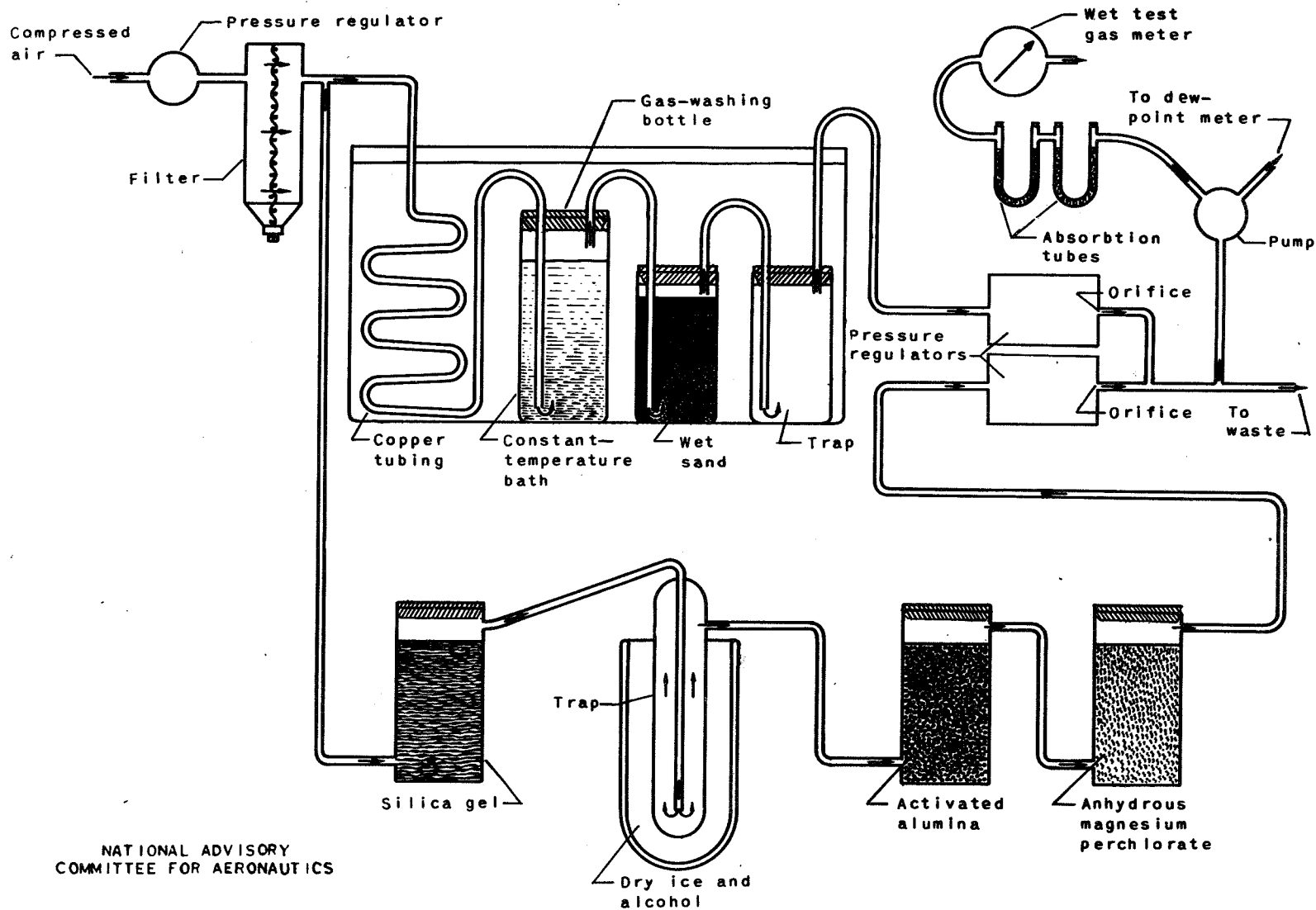

Figure 7. - Temperature of ice and supercooled water in equilibrium with water vapor. (Data from reference 4.)



NATIONAL ADVISORY  
COMMITTEE FOR AERONAUTICS

Figure 8. - Calibration apparatus for NACA dew-point meter.

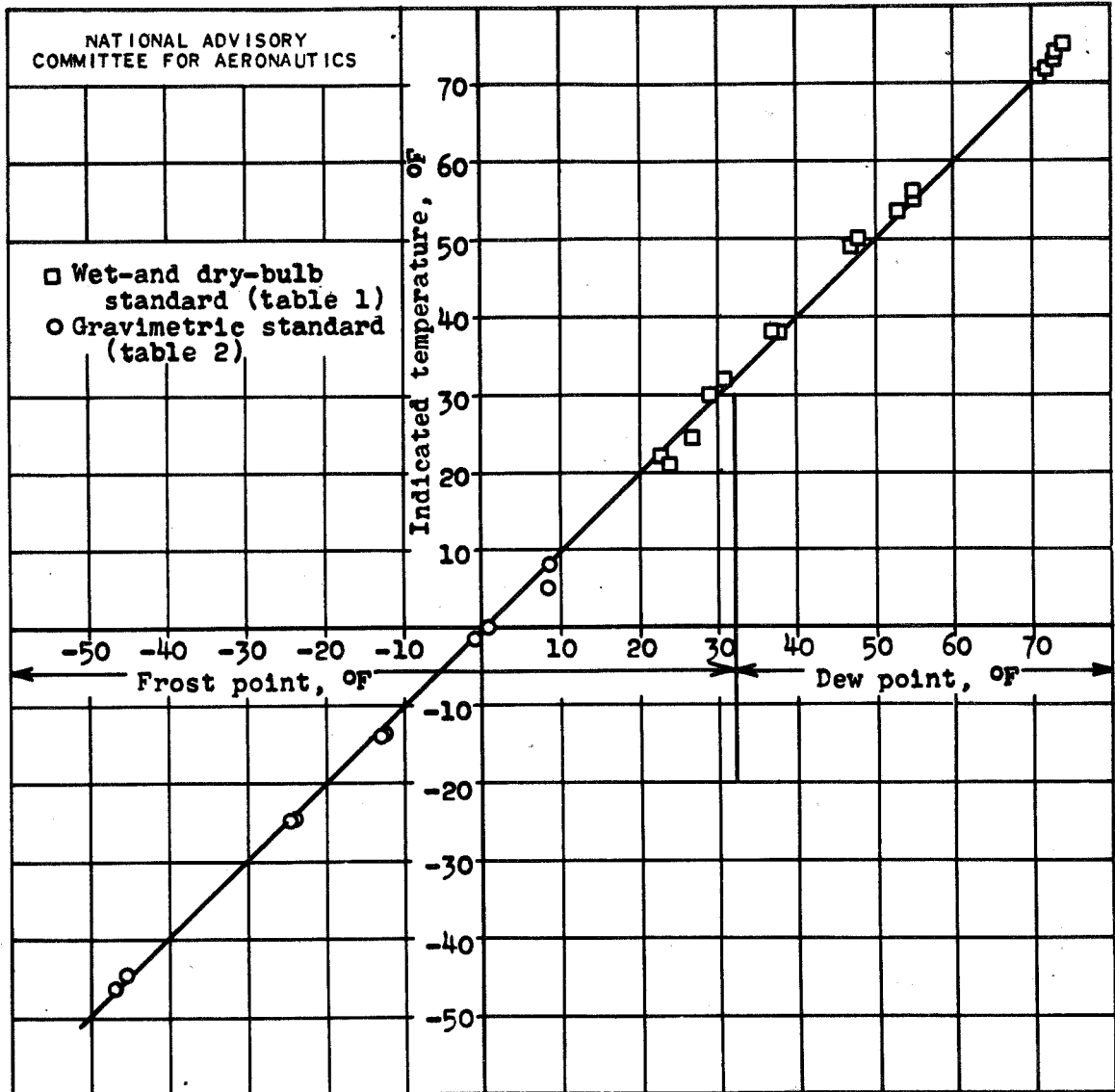
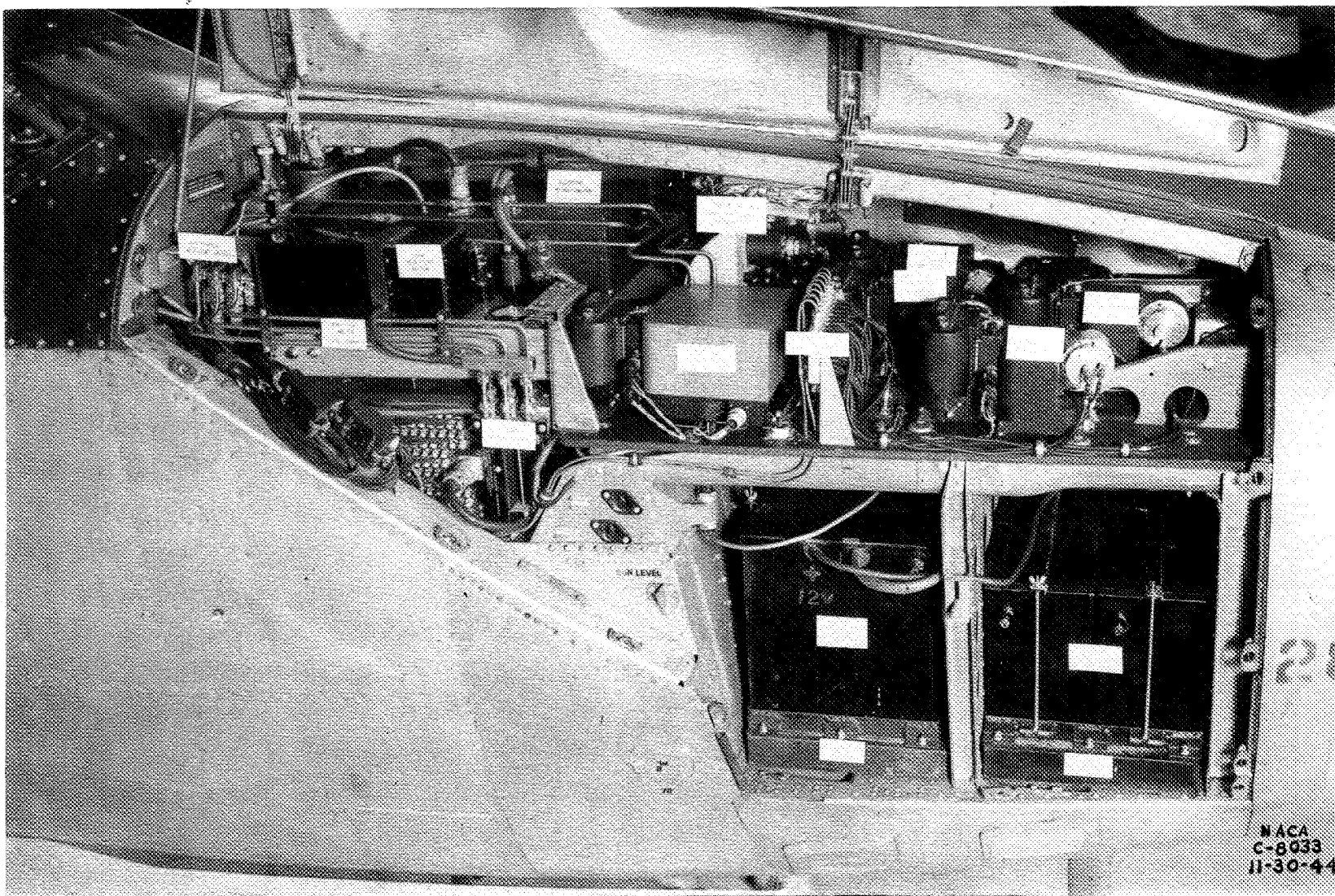

Figure 9. - Calibration of NACA dew-point meter.



NACA  
C-6033  
11-30-44

Fig. 10

Figure 10. - Instrument installation for study of icing in military airplane.

**TITLE:** An Improved Continuous-Indicating Dew-Point Meter

**AUTHOR(S)** : Friswold, Frank A.; Lewis, Ralph D.; Wheeler, R. C.  
**ORIG. AGENCY** : Aircraft Engine Research Lab., Cleveland, Ohio  
**PUBLISHED BY** : National Advisory Committee for Aeronautics, Washington, D. C.

ATI-8021

DEVISION  
(None)

ORIG. AGENCY NO.  
TN-1215

PUBLISHING AGENCY NO.  
(Same)

DATE	DOC. CLASS.	COUNTRY	LANGUAGE	PAGES	ILLUSTRATIONS
Feb '47	Unclass.	U.S.	English	24	photos, tables, diagr, graphs

**ABSTRACT:**

Dew-point meter that automatically maintains a mirror surface at dew point has been developed. Heat conducted from mirror to a coolant is balanced by heat generated at mirror surface by radio-frequency induction heating. This heating is controlled by a photoelectric bridge circuit that detects formation of dew on a mirror. This meter was used to measure moisture content of air in induction system of a military airplane during investigation of ice formation in induction system. Instrument was found to have average accuracy of  $\pm 1^{\circ}\text{F}$  over range of  $75^{\circ}$  to  $45^{\circ}\text{F}$ .

**DISTRIBUTION:** SPECIAL. All requests for copies must be addressed to: Publishing Agency.

**DIVISION:** Meteorology (30)  
**SECTION:** Equipment & Instruments (9)

**SUBJECT HEADINGS:** Humidity indicators (49733); Instruments, Meteorological (52201)

**ATI SHEET NO.:** R-30-9-8

Control Air Documents Office  
Wright-Patterson Air Force Base, Dayton, Ohio

**AIR TECHNICAL INDEX**