

~~W. MITCHELL~~

0144593

TECH LIBRARY KAFB, NM

14/17
8076

NATIONAL ADVISORY COMMITTEE FOR AERONAUTICS

TECHNICAL NOTE

No. 1417

HIGH-SPEED WIND-TUNNEL TESTS OF AN NACA 0009-64 AIRFOIL
HAVING A 33.4-PERCENT-CHORD FLAP WITH AN OVERHANG

20.1 PERCENT OF THE FLAP CHORD

By David B. Stevenson and Alfred A. Adler

Langley Memorial Aeronautical Laboratory
Langley Field, Va.



Washington
September 1947

AFMDC
TECHNICAL LIBRARY
AFL 2811

319.98/41



TECHNICAL NOTE NO. 1417

HIGH-SPEED WIND-TUNNEL TESTS OF AN NACA 0009-64 AIRFOIL

HAVING A 33.4-PERCENT-CHORD FLAP WITH AN OVERHANG

20.1 PERCENT OF THE FLAP CHORD

By David B. Stevenson and Alfred A. Adler

SUMMARY

Tests were conducted to investigate the effects of compressibility on a 5-inch-chord NACA 0009-64 airfoil section having a 33.4-percent-chord flap with a nose overhang of 20.1 percent of the flap chord and a 0.017-percent-chord unsealed gap. Airfoil lift and pitching moment and flap hinge moment were obtained over an angle-of-attack range of 6° and a flap-angle range of 16° from a Mach number of 0.4 to the maximum (choking) Mach number that could be obtained for each configuration.

The results showed that, in general, the flap effectiveness decreased with an increase in Mach number. The rate of change of hinge-moment coefficient with both angle of attack and flap deflection $(\partial c_h / \partial \alpha)_\delta$ and $(\partial c_h / \partial \delta)_\alpha$ became more positive with increase in Mach number in the subcritical speed range. The forces and moments caused by deflection of the flap changed abruptly with a change in Mach number in the supercritical speed range.

In general, the flap effectiveness was greater throughout the speed range and the variation in $(\partial c_h / \partial \alpha)_\delta$ and $(\partial c_h / \partial \delta)_\alpha$ with Mach number was less for the NACA 0009-64 airfoil than for a similarly flapped airfoil of NACA 16-009 section previously tested.

The possibility that the trailing-edge angle may be used to control the variation of $(\partial c_h / \partial \delta)_\alpha$ or $(\partial c_h / \partial \alpha)_\delta$ with Mach number is shown.

INTRODUCTION

Flight and wind-tunnel studies have shown that compressibility will have serious adverse effects on the characteristics of the

usual flap type control surface. In order to investigate these effects two flapped airfoils were tested in the Langley 24-inch high-speed tunnel. Tests of the first airfoil, an NACA 16-009, were reported in reference 1. The results of the tests of the second airfoil, an NACA 0009-64, are given herein.

SYMBOLS

M	stream Mach number
c_l	airfoil section lift coefficient
$c_{m_c/4}$	airfoil section pitching-moment coefficient about the quarter-chord point
c_h	flap section hinge-moment coefficient; based on c_f
δ	flap deflection; negative deflection is upward
α	angle of attack
ϕ	trailing-edge angle
R	radius
c_f	flap chord behind the hinge line
c	chord of airfoil with 0 flap deflection

When α , δ , and c_l are used as subscripts outside the parentheses, they signify that the quantity is held constant.

APPARATUS AND TESTS

The tests were conducted in the Langley 24-inch high-speed tunnel, which is described in reference 2. Recent modification to this tunnel, which reduced the model span exposed to the air stream from 24 to 18 inches (fig. 1), is described in reference 3.

The model spanned the test section, passing through holes in end plates in the tunnel walls. (See fig. 1.) These holes were of the same shape as the airfoil profile but were slightly larger. This arrangement approximated two-dimensional flow; hence, the

forces and moments obtained are essentially section characteristics. The model was a symmetrical airfoil made of steel with an NACA 0009-64 airfoil profile modified to have a 33.4-percent-chord flap with an overhang of 20.1 percent of the flap chord. The 0.017c gap was unsealed. A cross section of the model is shown as figure 2. The ordinates, except for the part of the airfoil affected by the flap nose and the gap, may be obtained from reference 4.

Airfoil lift and pitching moment were obtained by means of a spring-type balance similar to that described in reference 5. Flap hinge moments were measured by means of an electrical strain-gage system mounted on the balance.

The forces and moments were measured over an angle-of-attack range extending from -4° to 2° and a flap-deflection range from -6.1° to 9.9° .

The Mach number range for which the tests were made extended approximately from 0.40 to 0.85, corresponding to Reynolds numbers from 1,100,000 to 1,800,000.

FACTORS AFFECTING TEST RESULTS

Tunnel-Wall Effect

As was pointed out in reference 1, tunnel-wall corrections in the subcritical speed range for a low ratio of model to tunnel size such as existed in the present tests are small. No corrections have yet been determined for the supercritical speed range. For these reasons, no tunnel-wall corrections have been made to the force-test data presented herein. Serious constriction effects do occur, however, near the limiting or choking Mach number (reference 3). The onset of these effects was indicated to occur at Mach numbers about 0.02 to 0.03 below the choking Mach number by surveys of static pressure along the tunnel wall similar to those of reference 3. The results presented are, therefore, questionable in this speed range. In general, the highest Mach number for each configuration shown in the figures corresponds to the choking condition.

End-Gap Effects

During these tests, leakage occurred between the test section and the surrounding test chamber through the end-plate gaps at the junction between the model and the tunnel wall. The effect of this leakage upon lift and moment coefficient is shown in reference 2 by a comparison of force-test data with end-plate gaps and essentially two-dimensional pressure-distribution data obtained in the Langley 24-inch high-speed tunnel. Although the absolute values

obtained by the two methods differ to some extent, the results are in agreement as regards the effects of compressibility and therefore no correction for end leakage has been applied to the data presented herein. The effect of end gap on lift-curve slope is small since the effective aspect ratio of the model always remains above 20. The effects of end gap on hinge moments have been determined to be negligible.

Humidity Effects

At the higher tunnel speeds the relative humidity of the atmosphere, from which the air in the tunnel is drawn (reference 1), was found to affect the lift and moments under certain conditions. However, a value of relative humidity has been determined below which no measureable effects exist. The high-speed data contained herein were obtained with relative humidities less than this value.

RESULTS AND DISCUSSION

Lift

The effects of compressibility on the lift coefficient for constant angular conditions are shown in figure 3. The variation of lift coefficient with angle of attack and with flap deflection are presented in figures 4 and 5, respectively. The nonlinearity of the curves shown for low Mach numbers in figure 5 is essentially an increase in $dC_L/d\delta$ in the small flap-angle range between 3° and 4° , indicating an improved flow over the airfoil in this angular range. This improvement seems to be confined to the rear portion of the airfoil as indicated by the pitching-moment and hinge-moment data in this range. The nonlinearity cannot be attributed to inaccuracy in force measurements or in angular settings.

In figure 4, the decrease in the slope of the lift curves beyond an angle of attack of about -2.5° at Mach numbers of 0.775 or more indicates the effect of compressibility on separation of the air flow over the airfoil. Similarly, in figure 5 the slope of the curve of lift against flap deflection decreases above a Mach number of 0.75 for flap angles from $\pm 4^\circ$ to $\pm 6^\circ$. At flap angles above 6° some improvement in slope is evident for the very high Mach numbers. As noted in reference 1, data obtained from tests on other models, some at higher Reynolds numbers, indicate similar improvement in flap performance at comparatively large flap deflections.

The variations with Mach number of the slopes $\partial c_l / \partial \alpha$ and $\partial c_l / \partial \delta$, measured near zero lift in figures 4 and 5, are shown in figure 6. Values for the NACA 16-009 airfoil are included for comparison. These slopes result in the variation with Mach number of flap effectiveness $\partial \alpha / \partial \delta$ shown in figure 7.

Figure 6 shows that the lift parameters for the NACA 0009-64 airfoil were greater and varied more rapidly with Mach number than those for the NACA 16-009 airfoil throughout the speed range. The lower lift-curve slopes for the NACA 16-009 airfoil are believed to be associated with its larger trailing-edge angle (reference 6). Reference 7 shows that the unusually low values of $\partial c_l / \partial \delta$ and $\partial \alpha / \partial \delta$ for the NACA 16-009 airfoil may possibly be caused by the larger trailing-edge angle in the presence of an open gap. Low-speed data correlations show that, for plain flaps with sealed gaps, the value of $\partial \alpha / \partial \delta$ is less affected by alteration of trailing-edge angle alone. (See reference 8.)

As shown in figure 7, the NACA 0009-64 airfoil near zero lift had a flap effectiveness of about 0.48 at a Mach number of 0.4; the effectiveness decreased to a value of 0.34 at a Mach number of 0.83. It should be noted that these values are valid only for lift coefficients very near zero lift. Included in this figure is a value of elevator effectiveness obtained in the Langley Stability Research Division by an empirical method based on data from tests at Mach numbers near 0.1 and at Reynolds numbers which were higher than those obtained in the present investigation.

The marked changes in lift characteristics that occurred within 0.025 of the highest Mach numbers were influenced by tunnel-wall effects since the speeds were near choking values, but they illustrate the nature of the variations to be expected.

Pitching Moment

Variations in the quarter-chord pitching-moment coefficient with Mach number for constant angular conditions are shown in figure 8. The effect of compressibility on the variations of airfoil section pitching-moment coefficient with lift coefficient for a constant flap deflection and for a constant angle of attack is shown in figures 9 and 10, respectively. In order to indicate center-of-pressure shifts with Mach number, the parameters

$\left(\frac{\partial c_{m_c/4}}{\partial c_l} \right)_\delta$ and $\left(\frac{\partial c_{m_c/4}}{\partial c_l} \right)_\alpha$ were plotted in figures 11 and 12.

Hinge Moment

The effect of compressibility on the flap section hinge-moment coefficient for constant angular conditions is presented in figure 13. The variations of hinge-moment coefficient with angle of attack and with flap deflection are shown in figures 14 and 15, respectively. The curves in these two figures indicate that, in certain ranges of flap deflection, changes in speed may produce irregular variations in stick force and even stick-force reversals. The variations with Mach number of $\partial c_h / \partial \alpha$ and $\partial c_h / \partial \delta$ for $\alpha = 0^\circ$, $\delta = -0.1^\circ$ are given in figure 16. These slopes apply over a very limited range of angle of attack and flap deflection, as is evident from figures 14 and 15. Figures 13 and 15 show that, at the higher flap angles, marked changes in the hinge-moment characteristics occurred in the speed range above $M = 0.7$. Pressure-distribution data and schlieren flow photographs obtained in the Langley rectangular high-speed tunnel in investigations of other flapped airfoils have shown that abrupt changes in hinge-moment characteristics occurred when the critical speed was exceeded. These effects arose from the passage of shock waves across the flap.

Included in figure 16 for comparison with the results of the tests are estimated values of $\partial c_h / \partial \alpha$ and $\partial c_h / \partial \delta$ obtained from empirical methods presented in reference 8. Comparison of the hinge-moment parameters for the two airfoils at the lowest test speed ($M = 0.4$) showed qualitatively the effect of changes in trailing-edge angle as expected from low-speed research. However, the difference in Reynolds number and Mach number between the empirically established data and the test data prevents a direct quantitative comparison.

Comparison of the rate at which the hinge-moment parameters vary with Mach number for the subject tests and for the NACA 16-009 airfoil model (trailing-edge angle = 22°) showed that the model with the smaller trailing-edge angle had much less rapid change in the hinge-moment slopes $\partial c_h / \partial \alpha$ and $\partial c_h / \partial \delta$. References 9 and 10, tests of full-scale three-dimensional tail surfaces with sealed and 0.005c gaps and for smaller trailing-edge angles (12° and 13°), show that there was only slight variation in $\partial c_h / \partial \alpha$ with Mach number and that $\partial c_h / \partial \delta$ increased negatively. These results suggest the possibility of controlling the variation of $\partial c_h / \partial \delta$ or $\partial c_h / \partial \alpha$ with Mach number through proper selection of the trailing-edge angle. More high-speed data are needed to show the effects of associated flap-shape parameters before selection of the desired trailing-edge angles for a particular design can be made.

CONCLUSIONS

The results of the present high-speed wind-tunnel investigation of a 5-inch-chord NACA 0009-64 airfoil having a 33.4-percent-chord flap with a nose overhang of 20.1 percent of the flap chord and a 0.017-percent-chord unsealed gap can be summarized as follows:

1. The elevator-effectiveness factor $\partial\alpha/\partial\delta$ for small angle-of-attack and flap-angle increments was 0.43 at a Mach number of 0.4 but decreased to a value of 0.34 at a Mach number of 0.83.
2. At subcritical speeds the rate of change of hinge-moment coefficient with both angle of attack and flap deflection $(\partial c_h/\partial\alpha)_\delta$ and $(\partial c_h/\partial\delta)_\alpha$ showed increasing balance with increasing Mach number. At supercritical speeds abrupt and large variations in hinge-moment characteristics occurred.
3. Comparison of the results of the present investigation with previous results for the NACA 16-009 flapped airfoil shows that $(\partial c_l/\partial\alpha)_\delta$ and $(\partial c_l/\partial\delta)_\alpha$ for the NACA 0009-64 flapped airfoil (trailing-edge angle = 16°) were larger and increased more rapidly with Mach number than for the NACA 16-009 airfoil (trailing-edge angle = 22°). The hinge-moment parameters $(\partial c_h/\partial\alpha)_\delta$ and $(\partial c_h/\partial\delta)_\alpha$ were less affected by Mach number for the NACA 0009-64 airfoil than for the NACA 16-009 airfoil.
4. The possibility that the trailing-edge angle may be used to control the variation of $(\partial c_h/\partial\delta)_\alpha$ or $(\partial c_h/\partial\alpha)_\delta$ with Mach number is shown.

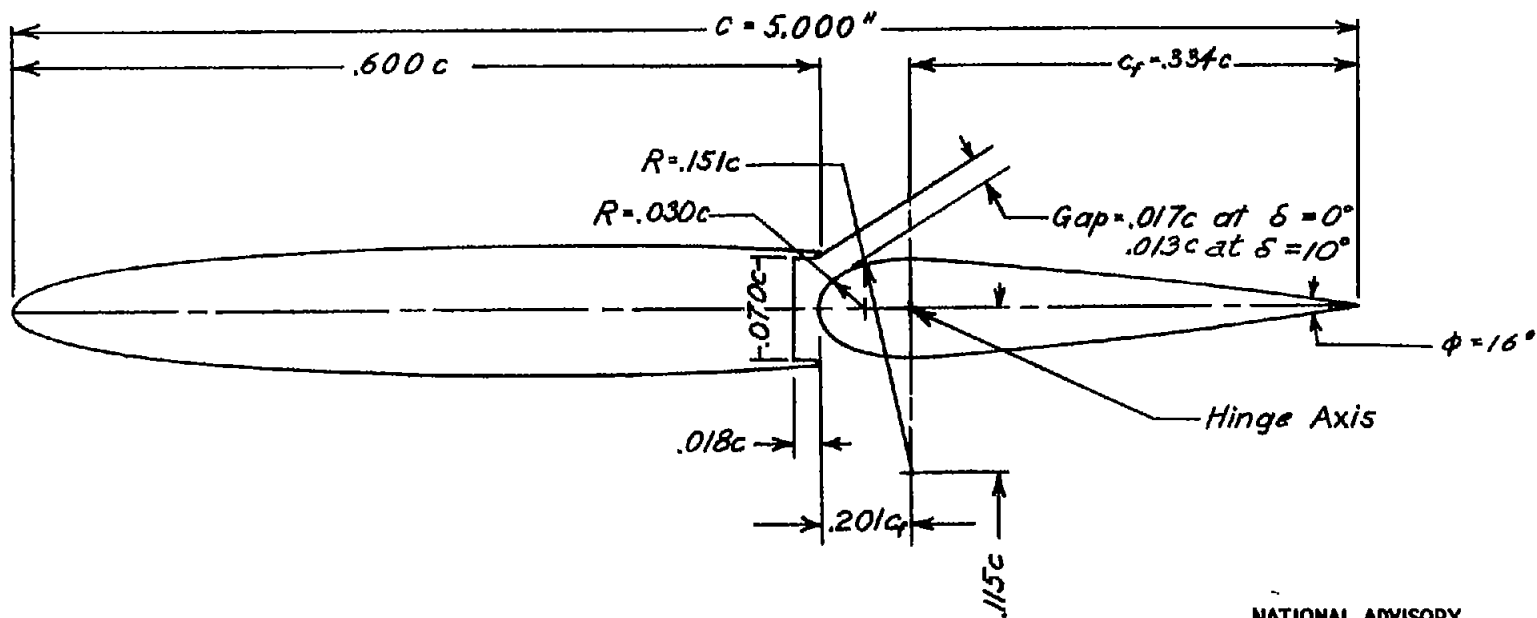
Langley Memorial Aeronautical Laboratory
National Advisory Committee for Aeronautics
Langley Field, Va., October 8, 1946

REFERENCES

1. Stevenson, David B., and Byrne, Robert W.: High-Speed Wind-Tunnel Tests of an NACA 16-009 Airfoil Having a 33-Percent-Chord Flap with an Overhang 21 Percent of the Flap Chord. NACA TN No. 1406, 1947.
2. Stack, John, Lindsey, W. F., and Littell, Robert E.: The Compressibility Burble and the Effect of Compressibility on Pressures and Forces Acting on an Airfoil. NACA Rep. No. 646, 1938.
3. Byrne, Robert W.: Experimental Constriction Effects in High-Speed Wind Tunnels. NACA ACR No. L4L07a, 1944.
4. Stack, John, and von Doenhoff, Albert E.: Tests of 16 Related Airfoils at High Speeds. NACA Rep. No. 492, 1934.
5. Stack, John: The N.A.C.A. High-Speed Wind Tunnel and Tests of Six Propeller Sections. NACA Rep. No. 463, 1933.
6. Jones, Robert T., and Ames, Milton B., Jr.: Wind-Tunnel Investigation of Control-Surface Characteristics. V - The Use of a Beveled Trailing Edge to Reduce the Hinge Moment of a Control Surface. NACA ARR, March 1942.
7. Purser, Paul E., and Riebe, John M.: Wind-Tunnel Investigation of Control-Surface Characteristics. XV - Various Contour Modifications of a 0.30-Airfoil-Chord Plain Flap on an NACA 66(215)-014 Airfoil. NACA ACR No. 3L20, 1943.
8. Langley Research Department: Summary of Lateral-Control Research. (Compiled by Thomas A. Toll.) NACA TN No. 1245, 1947.
9. Schueller, Carl F., and Korycinski, Peter F.: Effect of Fabric Deflection at High Speeds on the Aerodynamic Characteristics of the Horizontal Tail Surface of an SB2D-1 Airplane. NACA ARR No. L5F01a, 1945.
10. Schueller, Carl F., Korycinski, Peter F., and Strass, H. Kurt: Tests of a Full-Scale Horizontal Tail Surface in the Langley 16-Foot High-Speed Tunnel. NACA TN No. 1074, 1946.

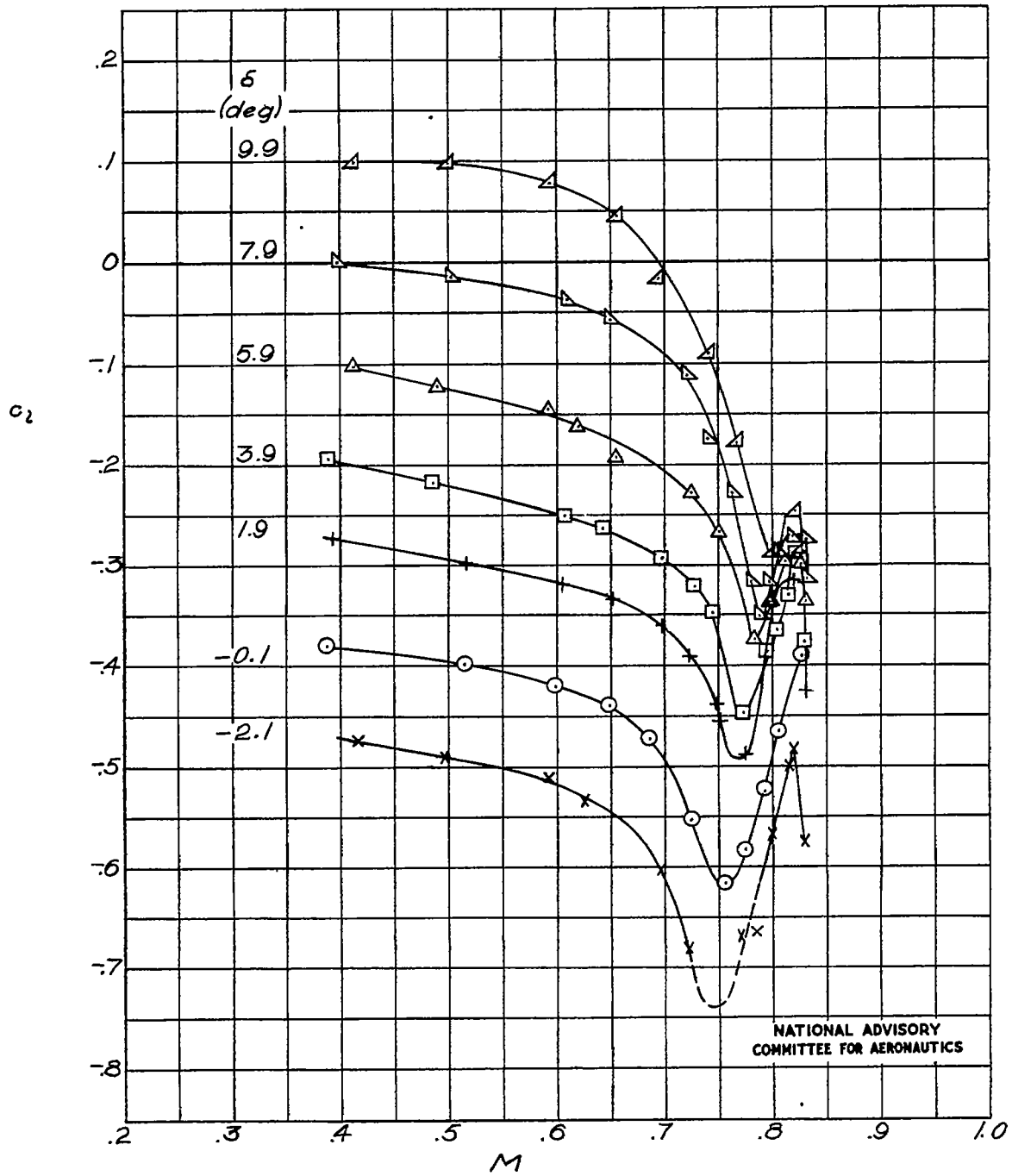


Figure 1.- Langley 24-inch high-speed tunnel test section with model mounted in balance.



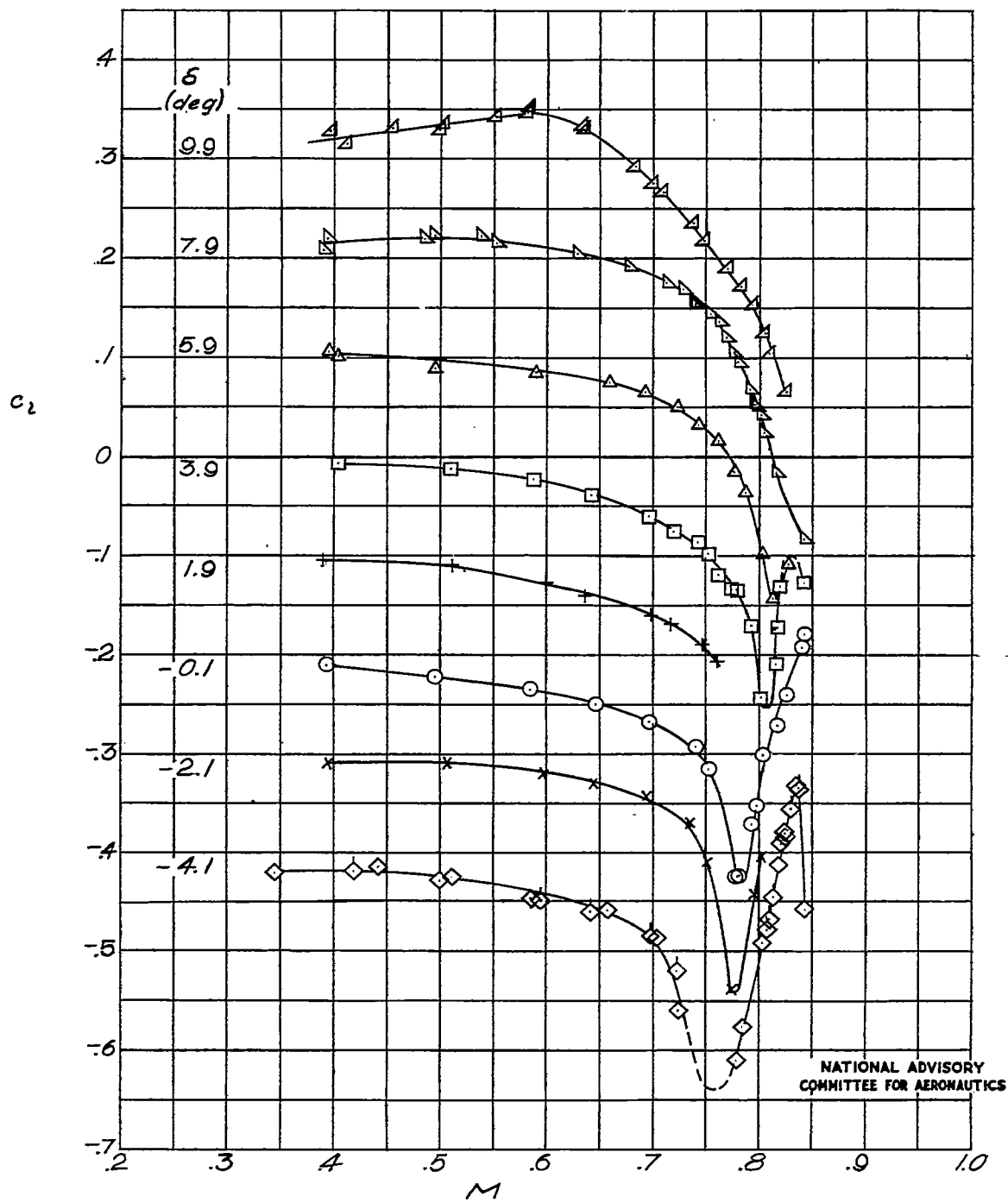
NATIONAL ADVISORY
COMMITTEE FOR AERONAUTICS

Figure 2. - NACA 0009-64 airfoil with a $0.334c$ flap having a $0.20c_f$ nose overhang.



(a) $\alpha = -4^\circ$.

Figure 3.- Variation of section lift coefficient with Mach number.



(b) $\alpha = -2^\circ$

Figure 3. - Continued.

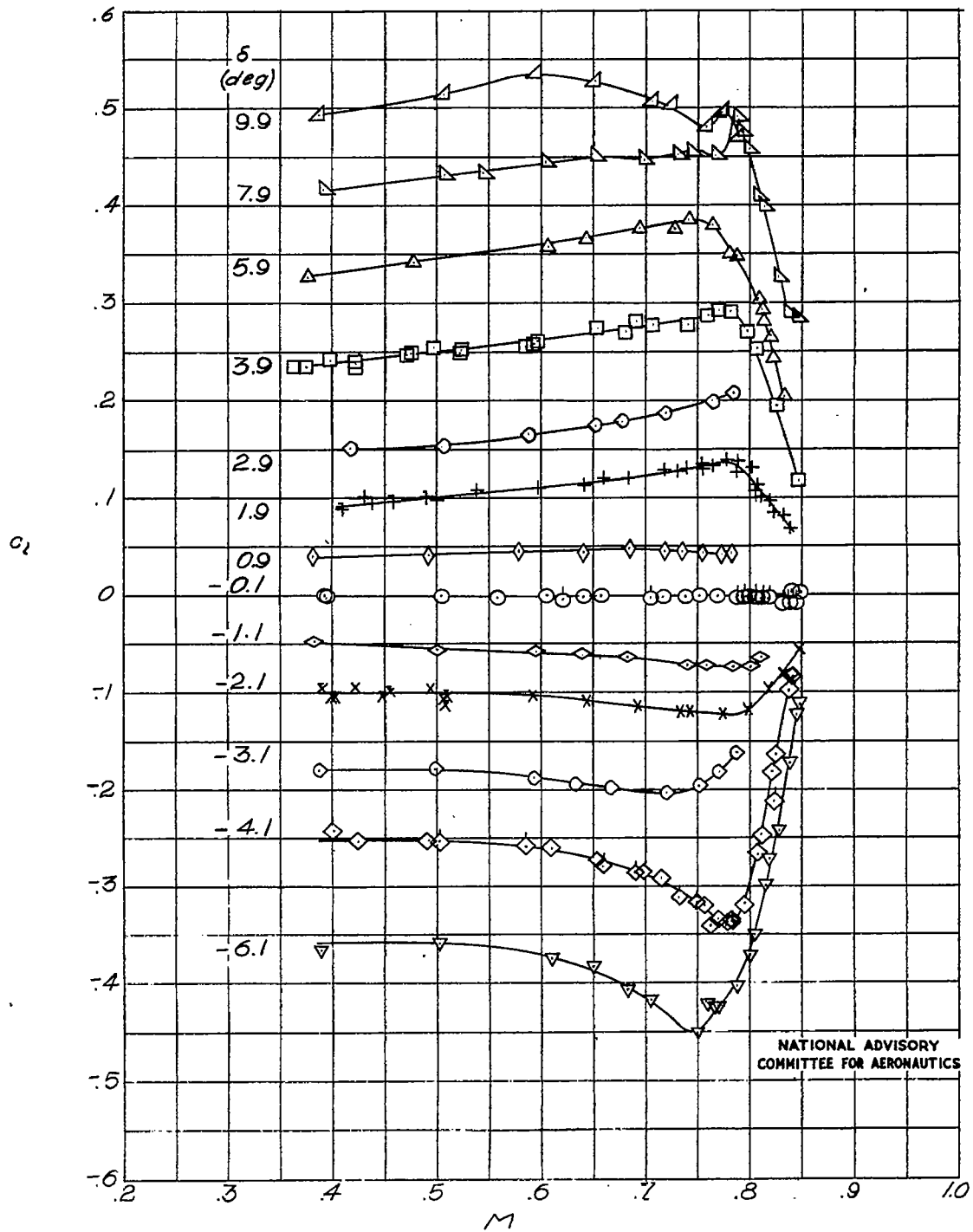
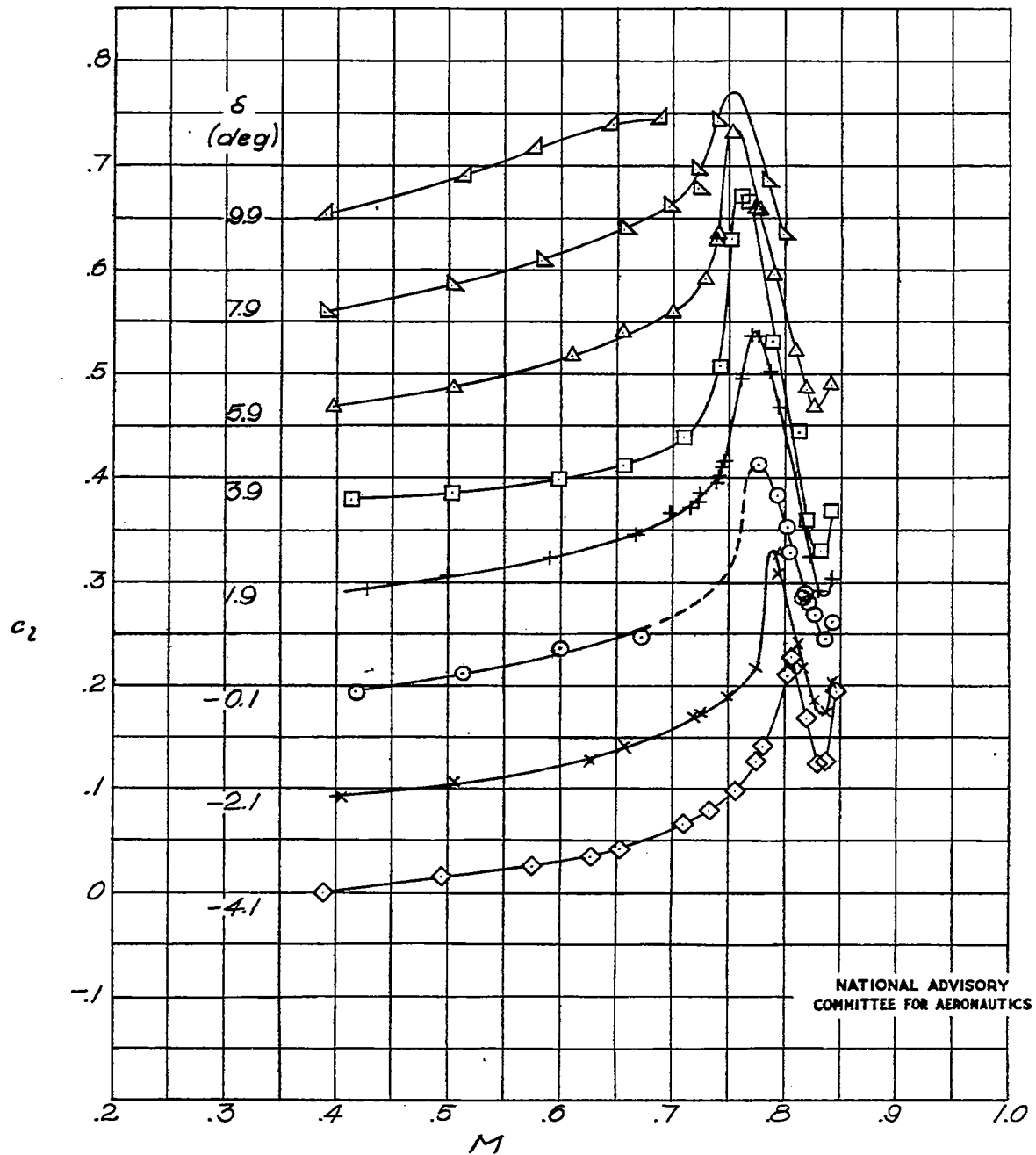
(c) $\alpha = 0^\circ$

Figure 3. -- Continued.



(d) $\alpha = 2^\circ$

Figure 3. - Concluded.

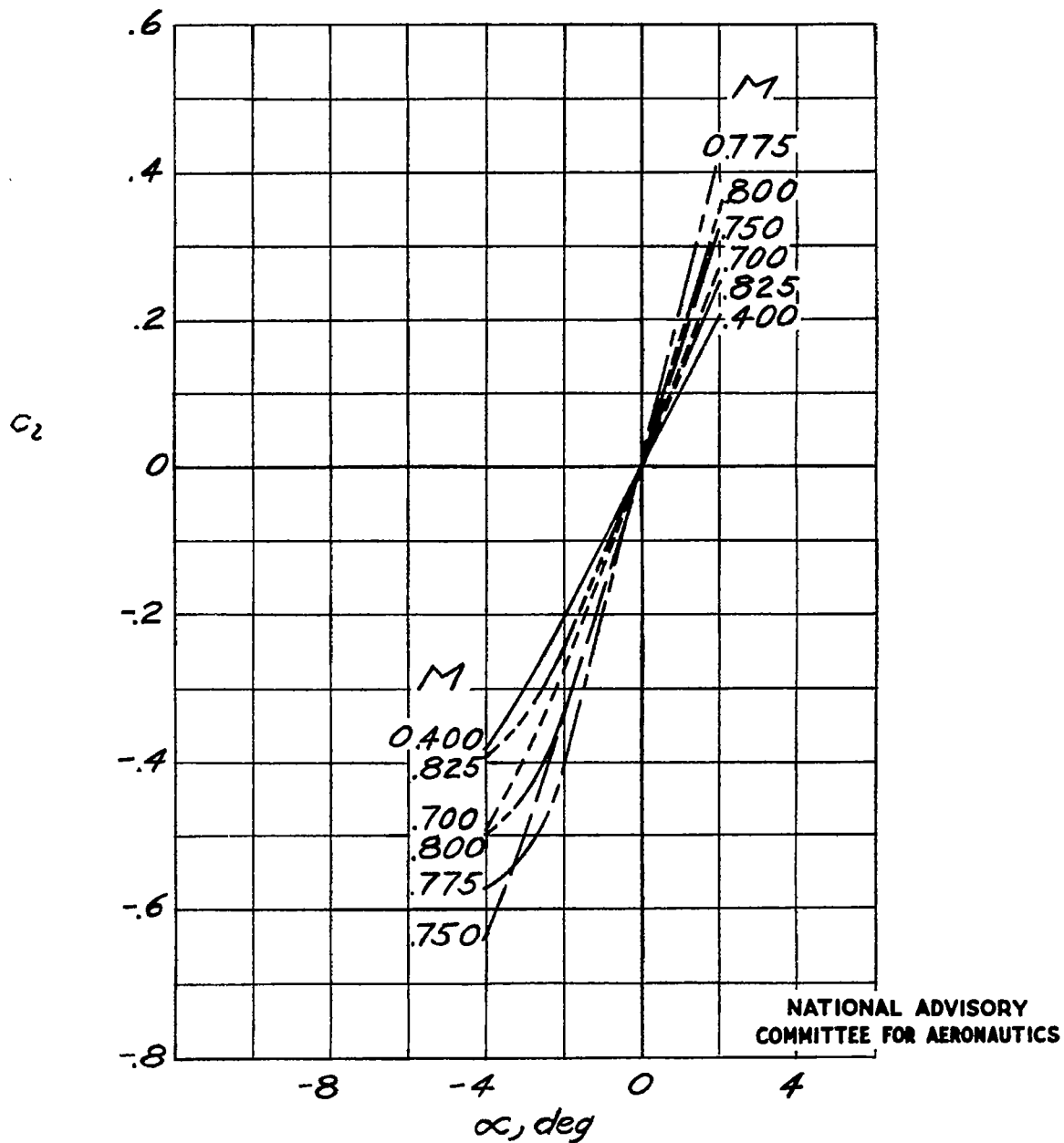


Figure 4. - Variation of section lift coefficient with angle of attack. $\delta = -0.1^\circ$.

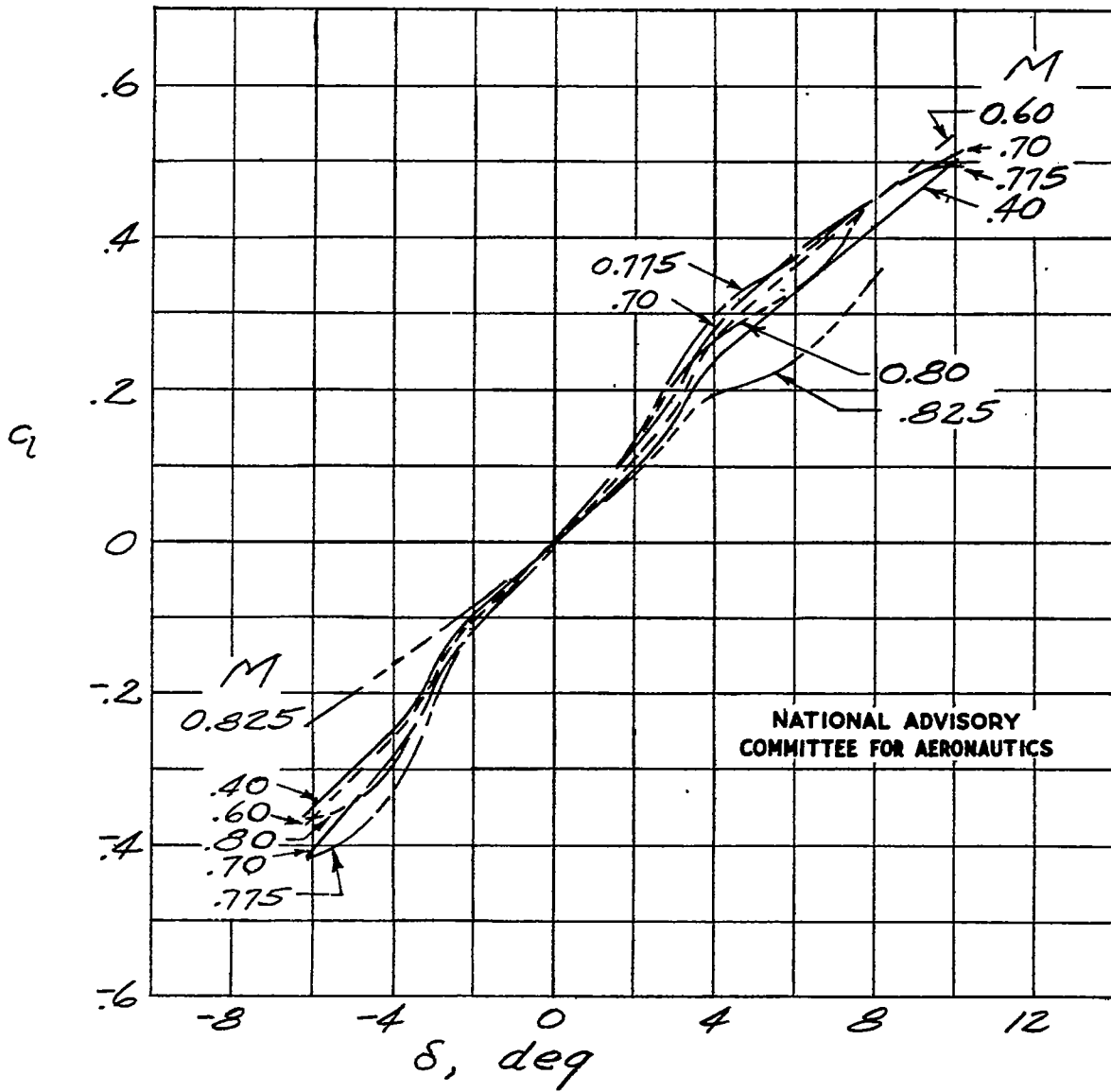


Figure 5. - Variation of section lift coefficient with flap deflection.
 $\alpha = 0^\circ$.

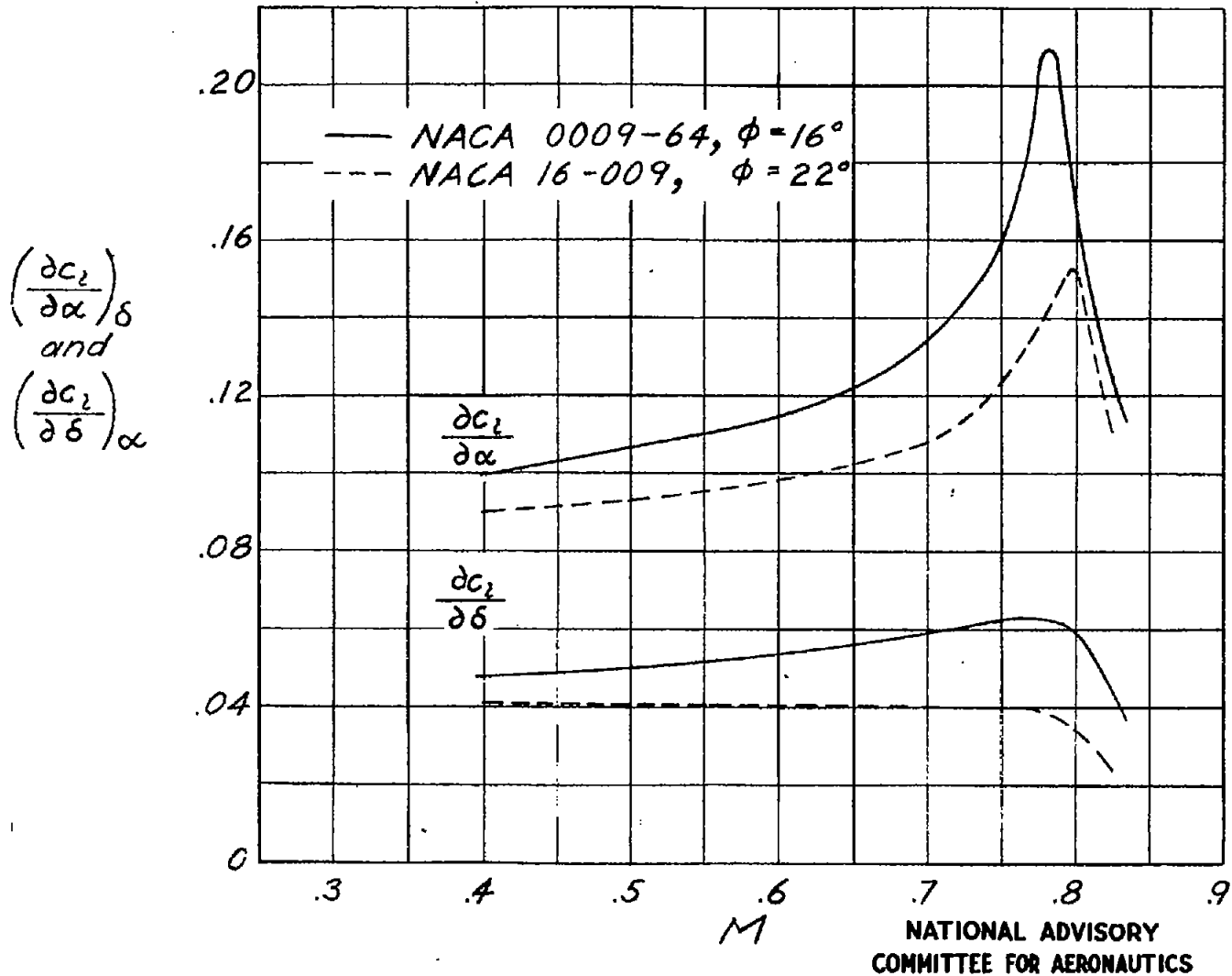


Figure 6. - Variation of lift curve slopes with Mach number.

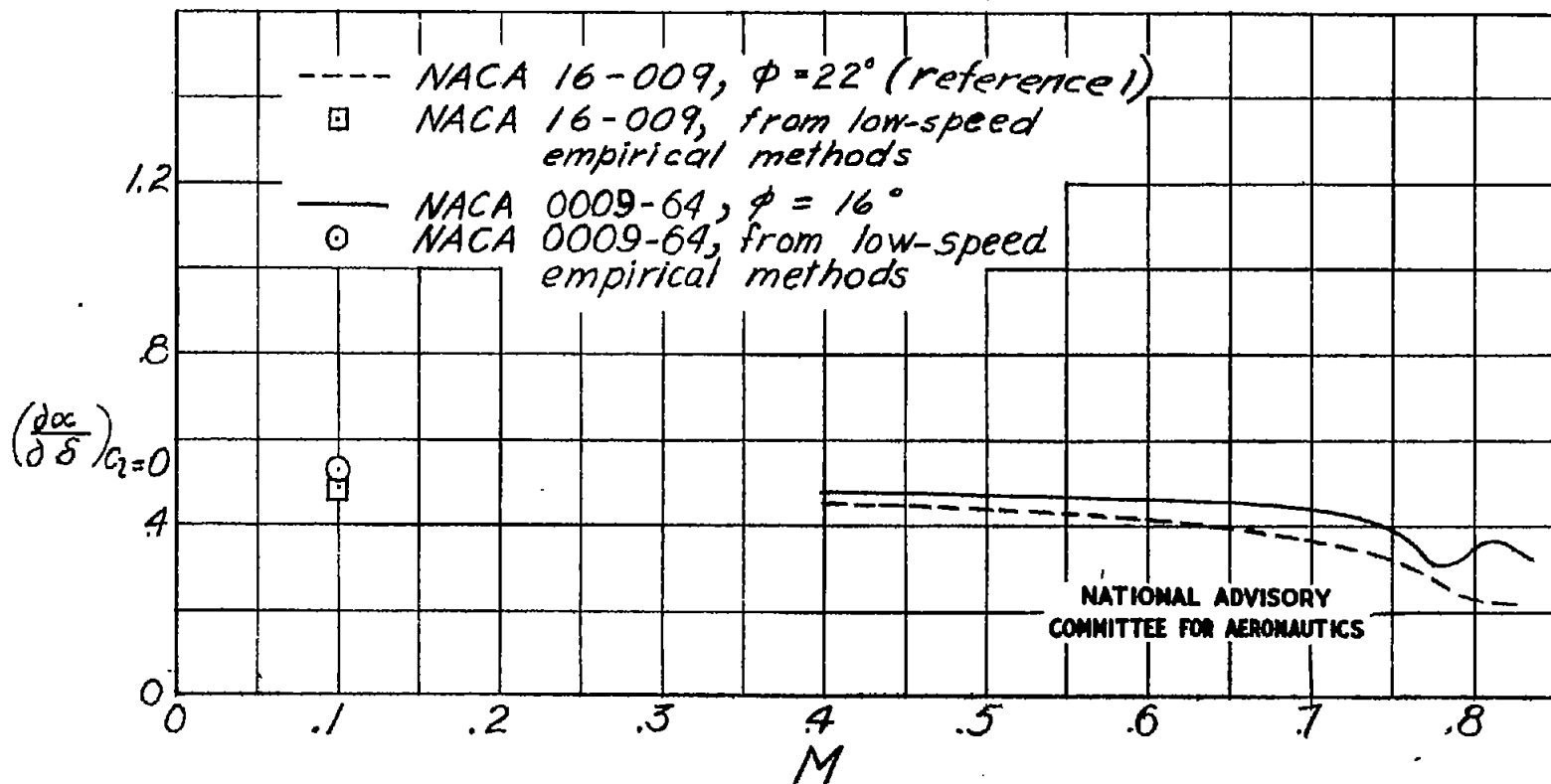
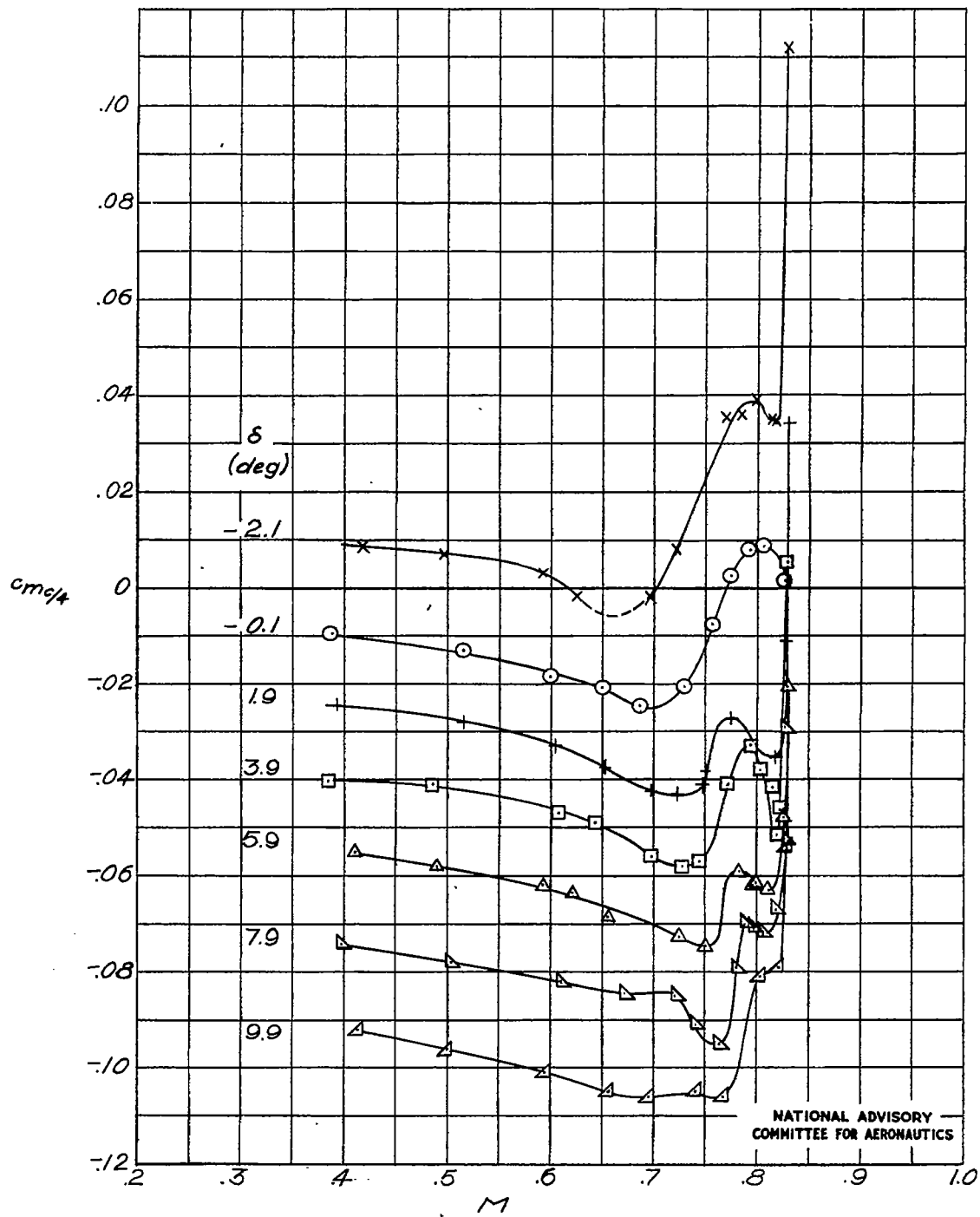
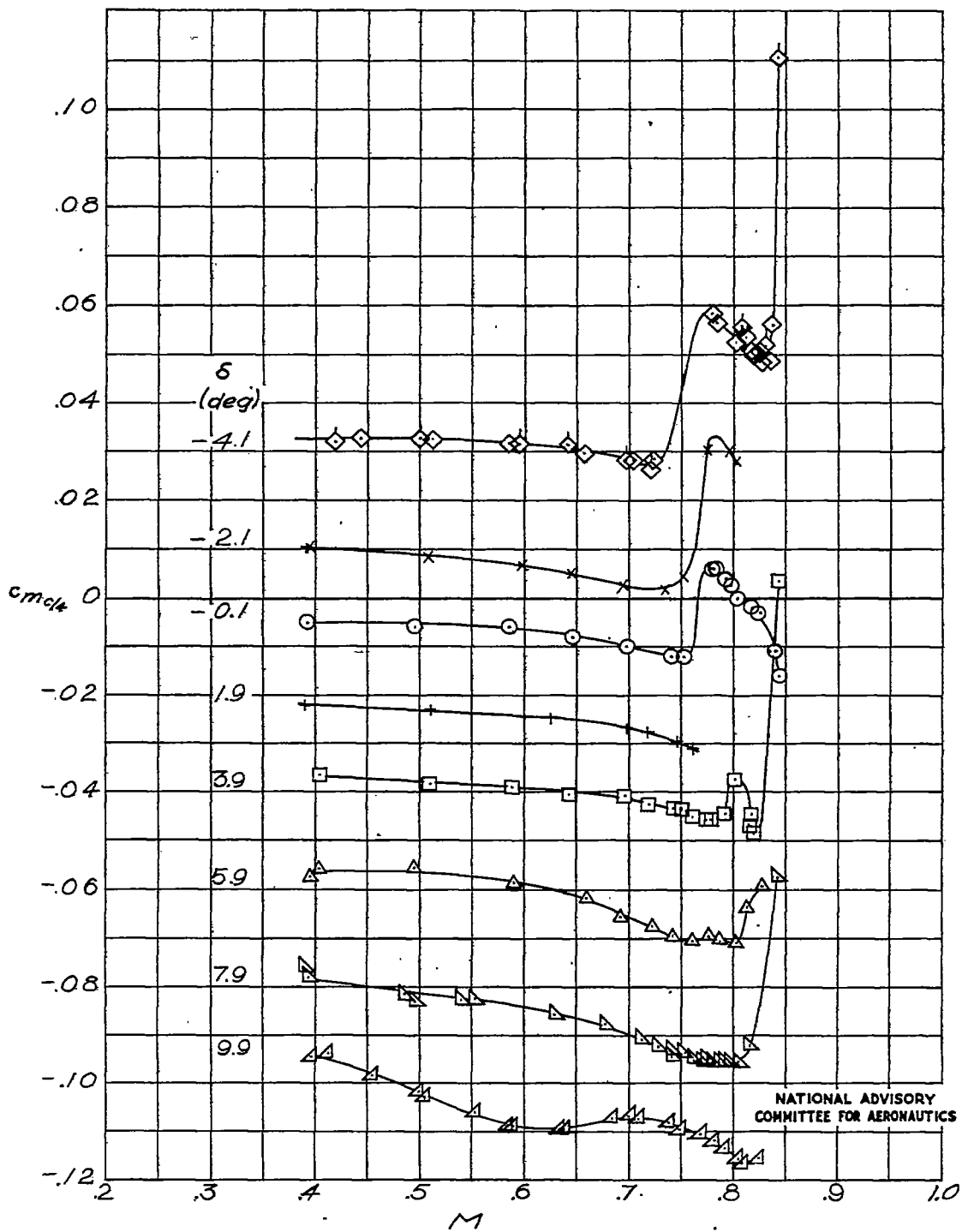


Figure 7. - Variation of flap effectiveness with Mach number.



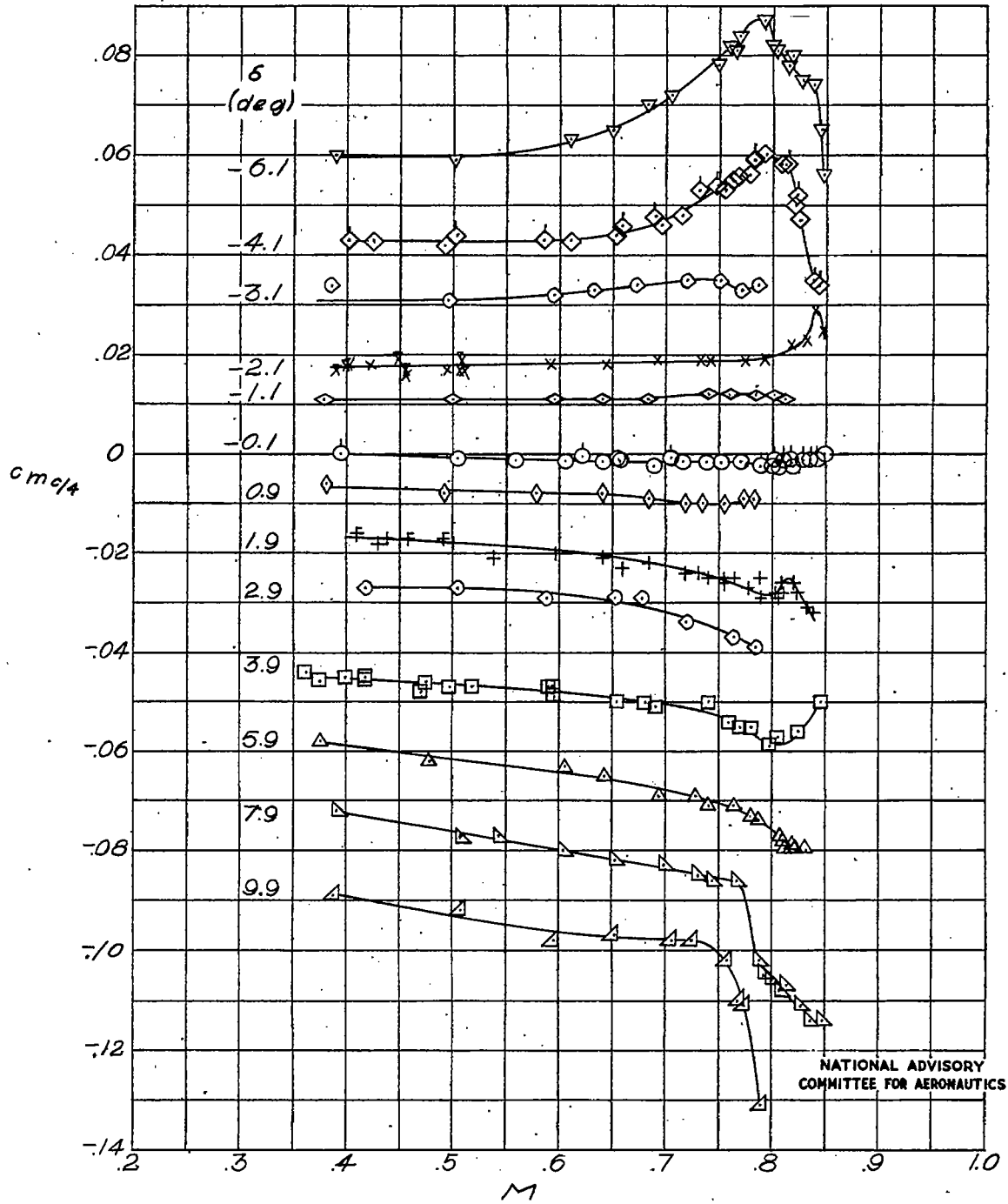
(a) $\alpha = -4^\circ$

Figure 8. - Variation of section quarter-chord moment coefficient with Mach number.



(b) $\alpha = -2^\circ$

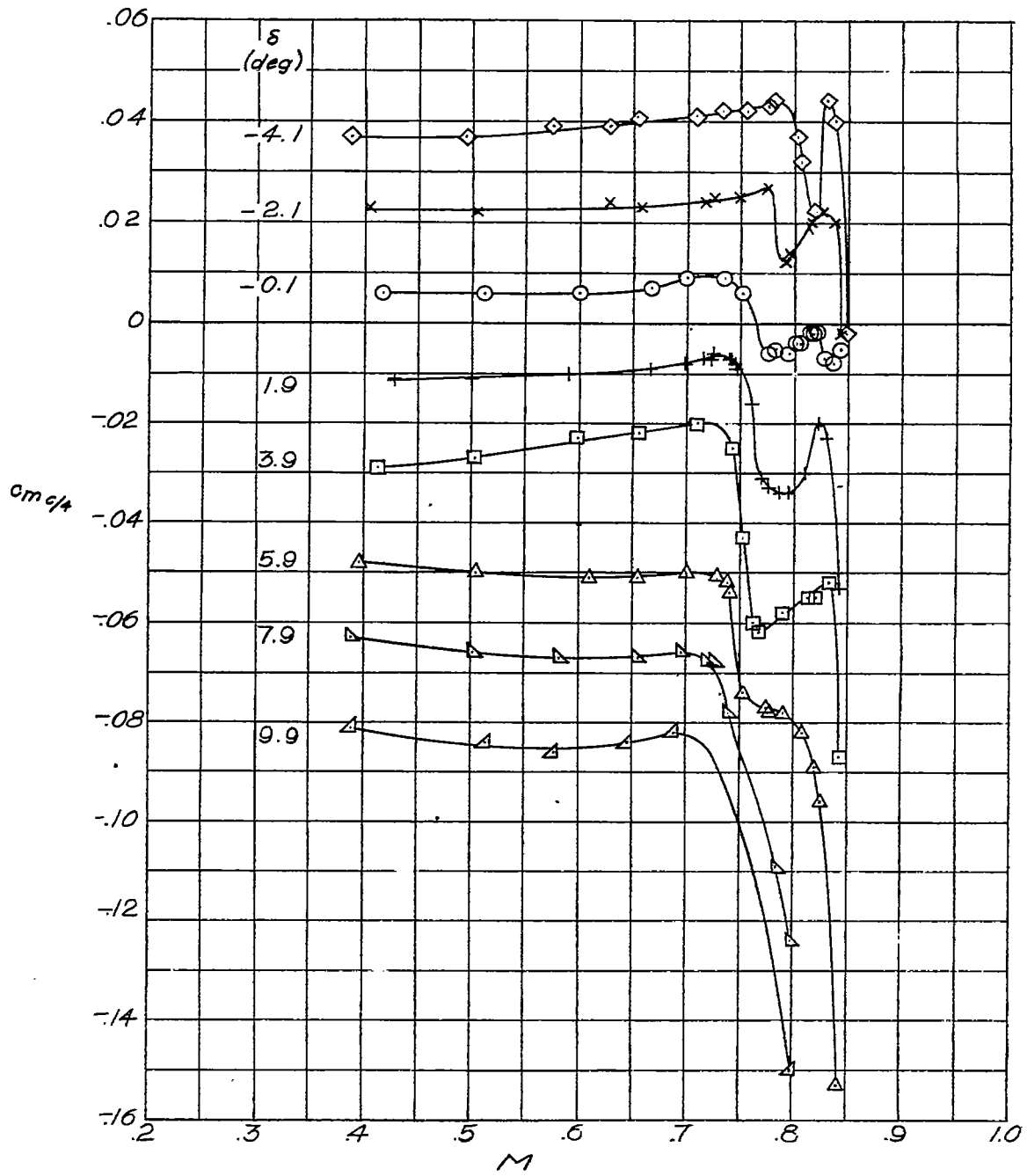
Figure 8. - Continued.



NATIONAL ADVISORY
COMMITTEE FOR AERONAUTICS

(c) $\alpha = 0^\circ$

Figure 8. - Continued.



NATIONAL ADVISORY
COMMITTEE FOR AERONAUTICS

(d) $\alpha = 2^\circ$

Figure 8. - Concluded.

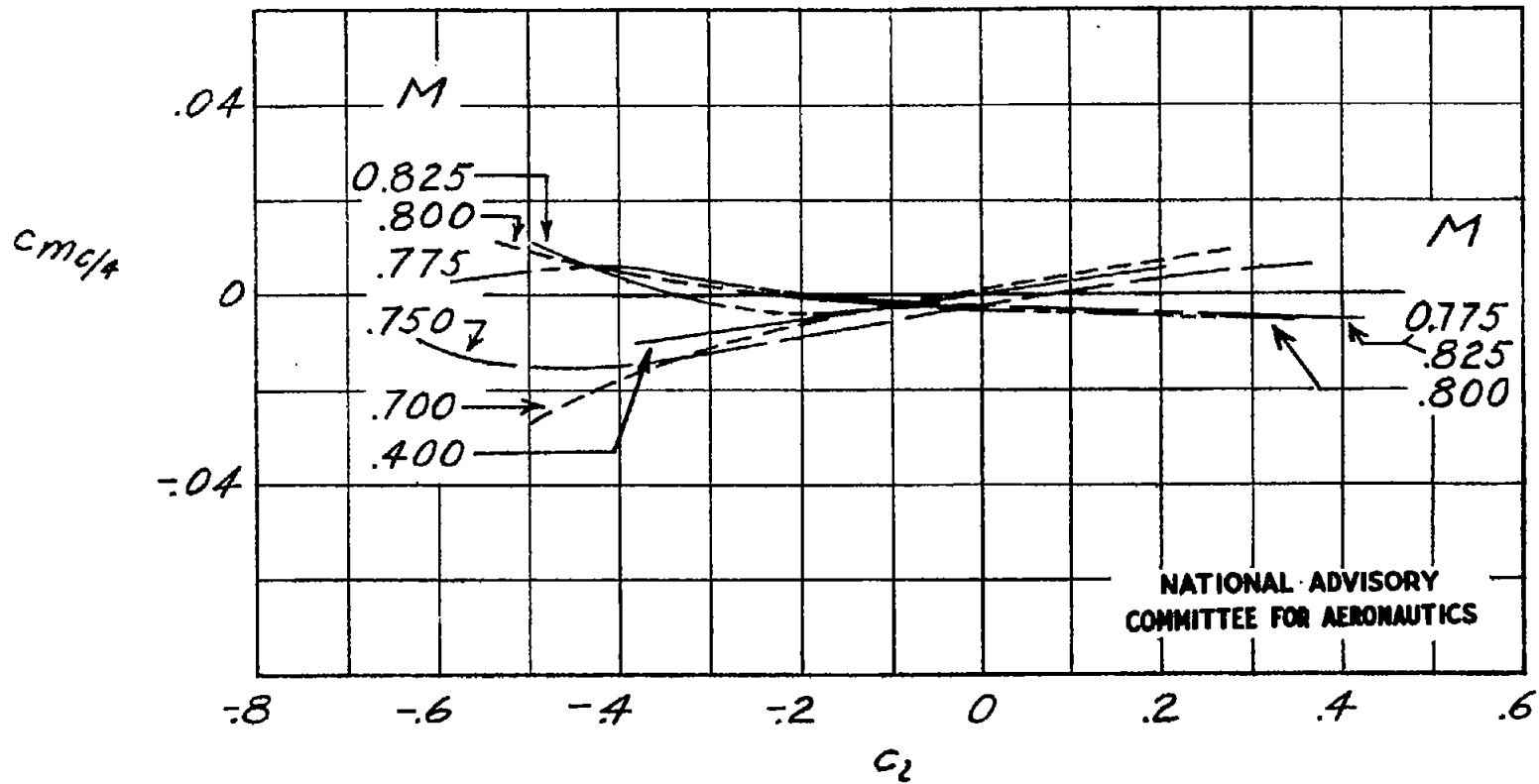


Figure 9. - Variation of section quarter-chord moment coefficient with section lift coefficient. $\alpha = -0.1^\circ$.

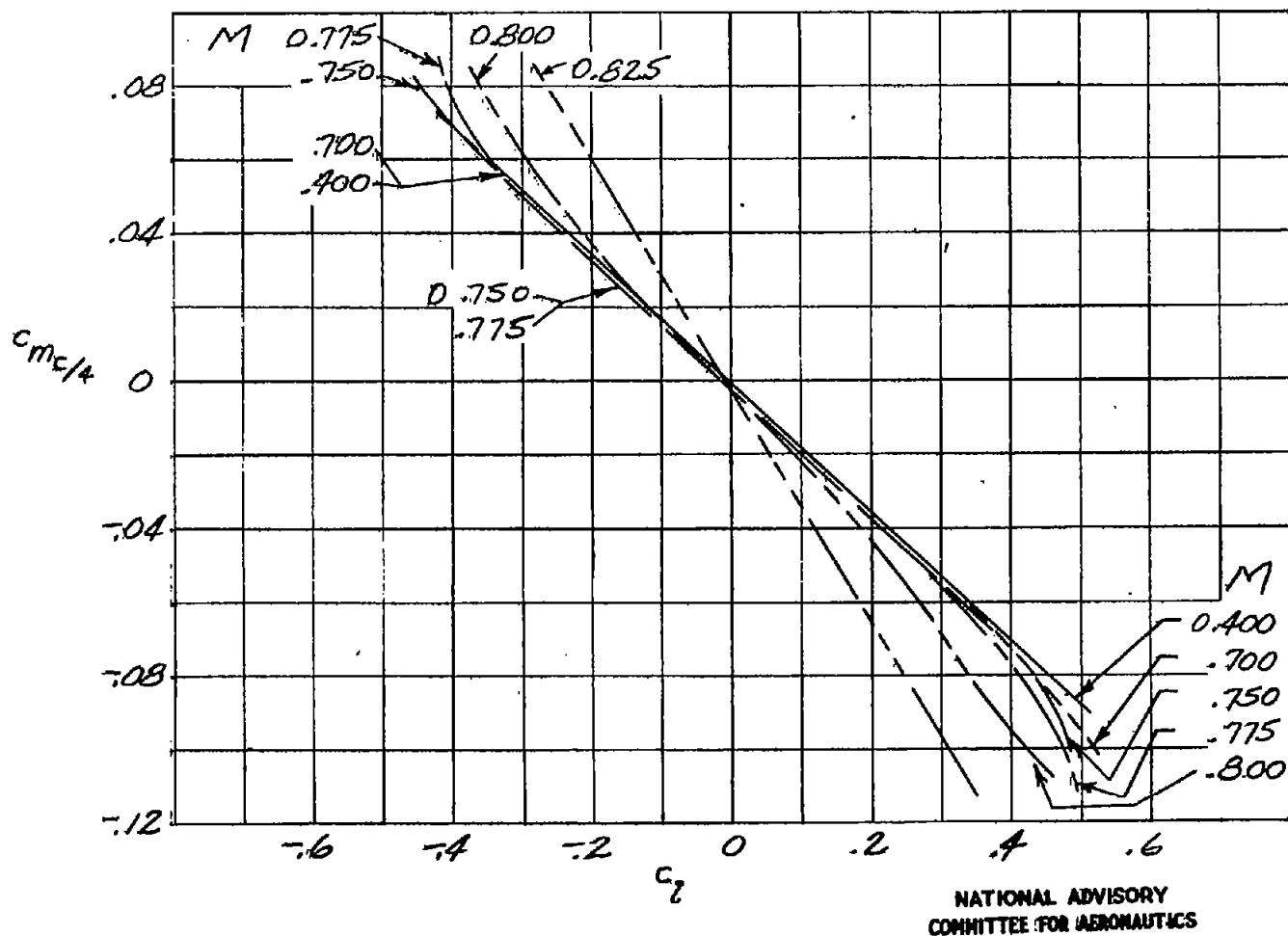


Figure 10.- Variation of section quarter-chord moment coefficient with section lift coefficient for a constant angle of attack, $\alpha = 0^\circ$.

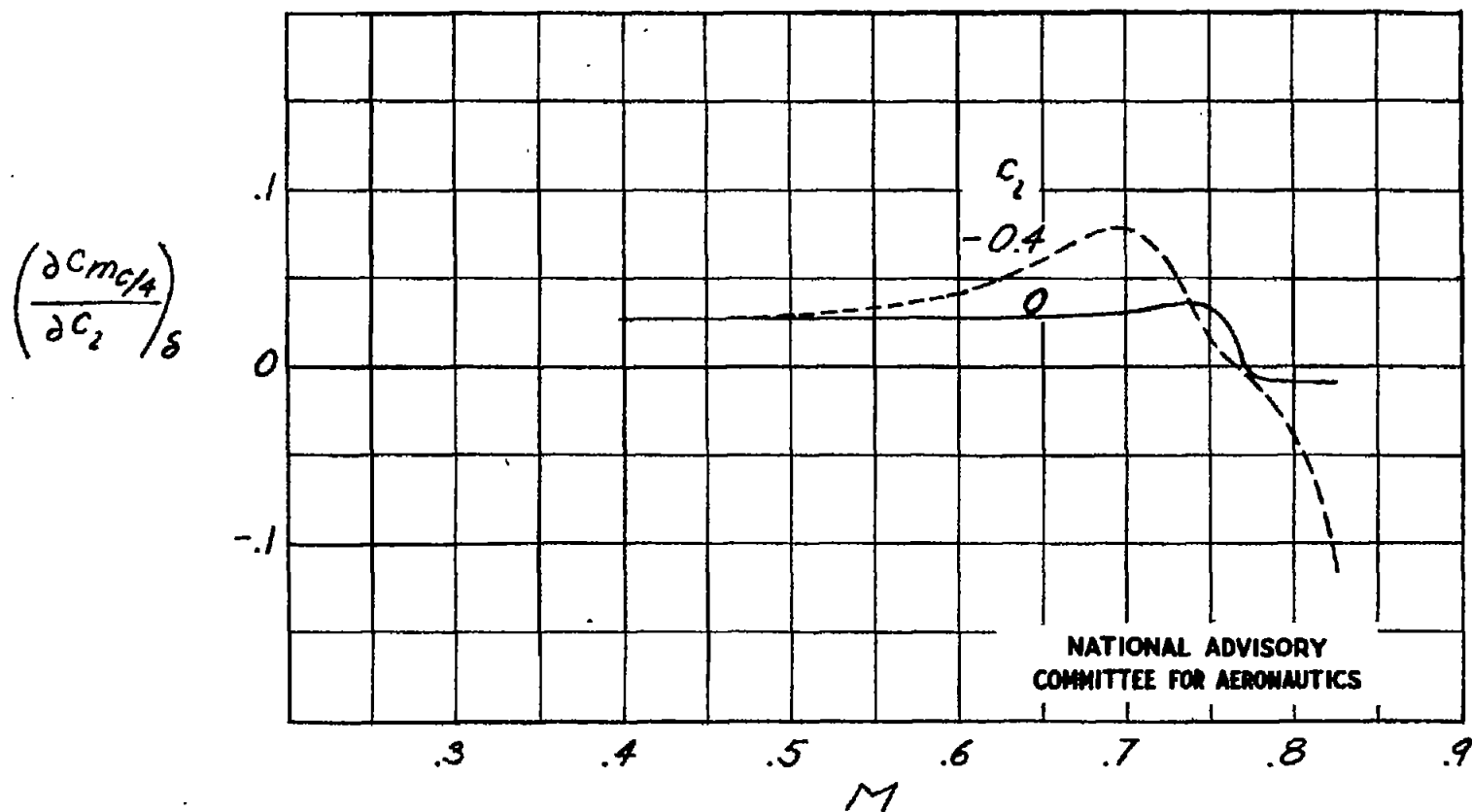
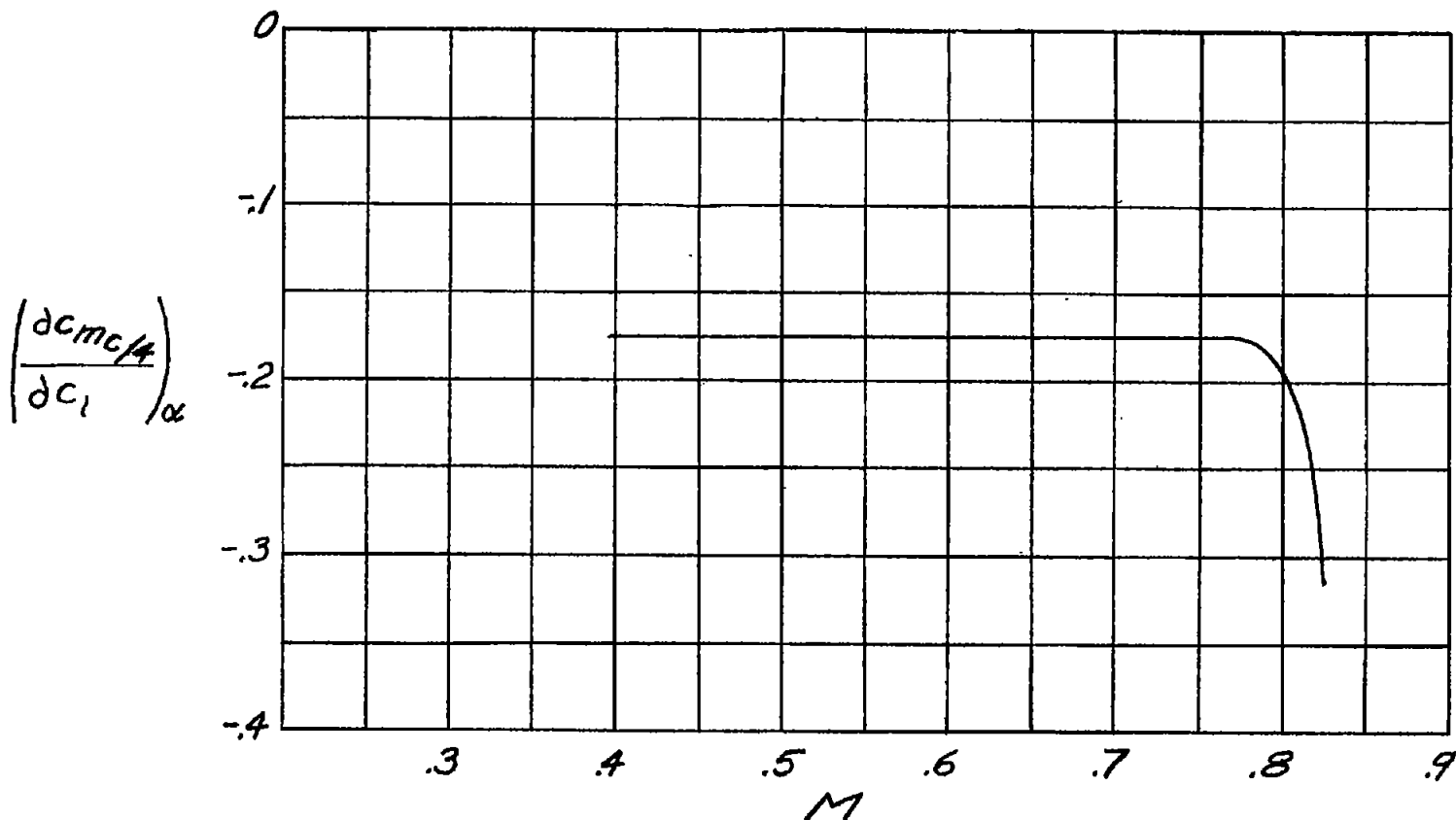


Figure 11.- Variation with Mach number of the rate of change of airfoil section moment coefficient with section lift coefficient for a constant flap deflection. $\delta = -0.1^\circ$.



NATIONAL ADVISORY
COMMITTEE FOR AERONAUTICS

Figure 12. - Variation with Mach number of the rate of change of airfoil section moment coefficient with section lift coefficient for a constant angle of attack. $\alpha = 0^\circ$.

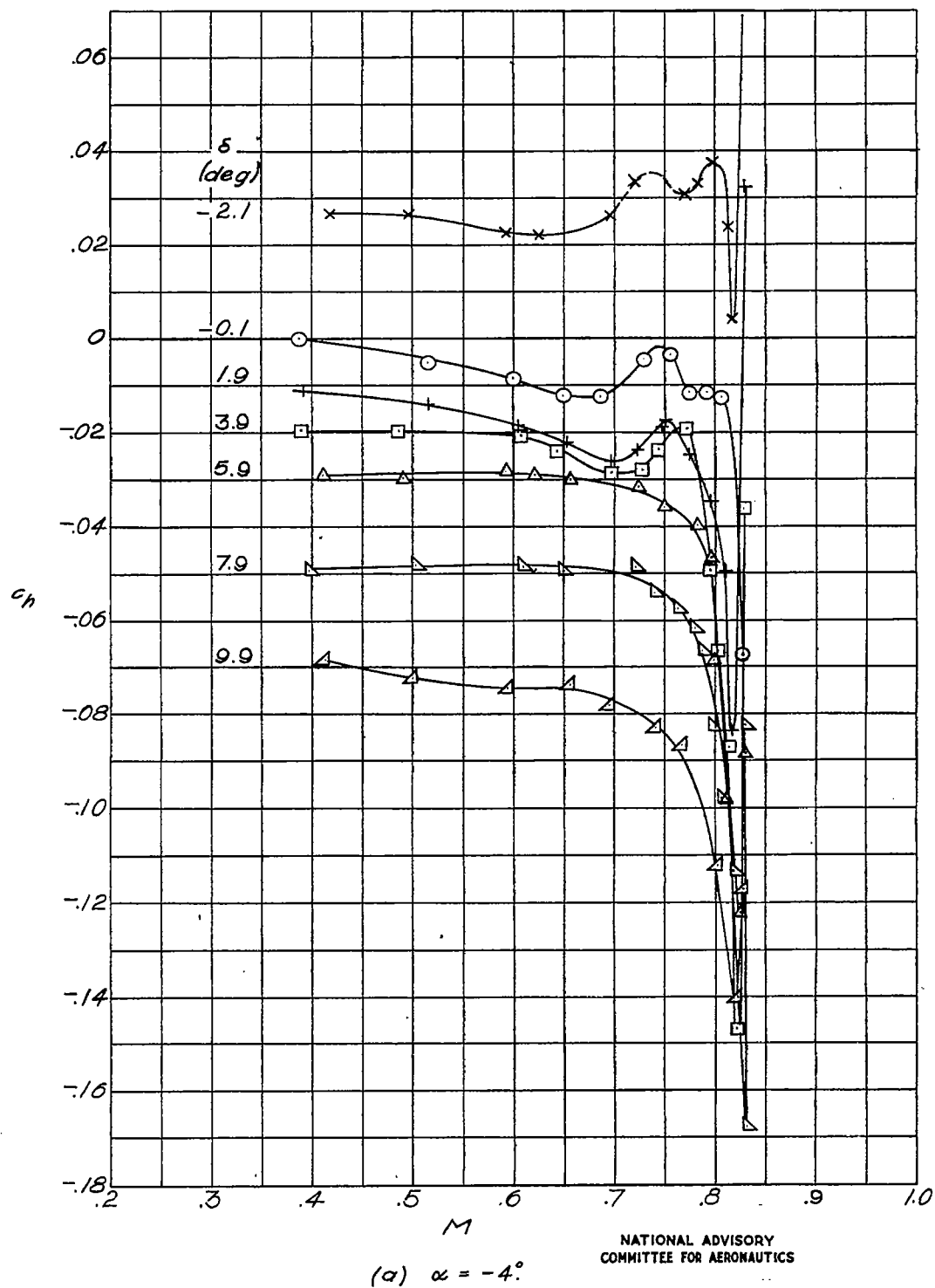
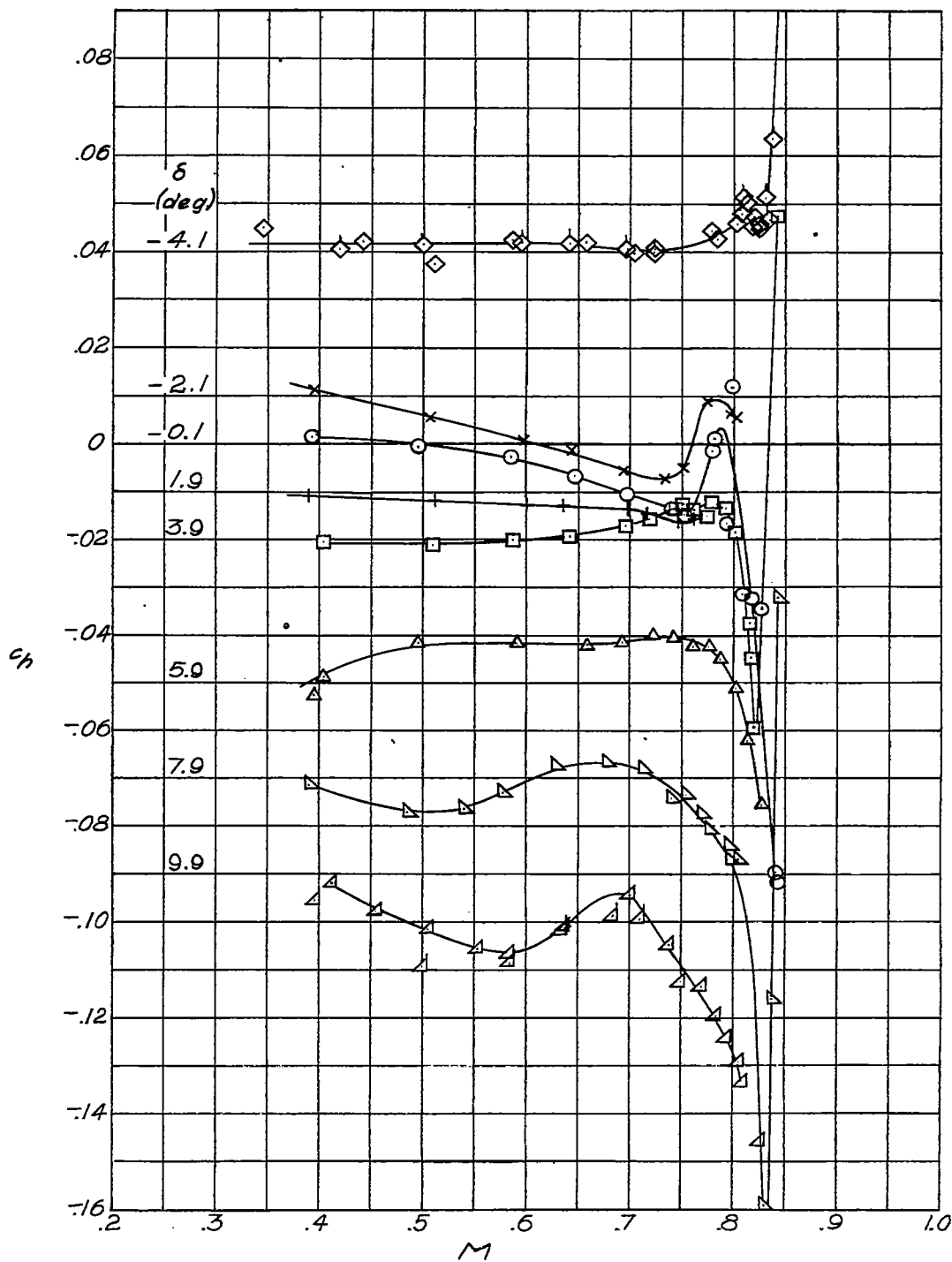


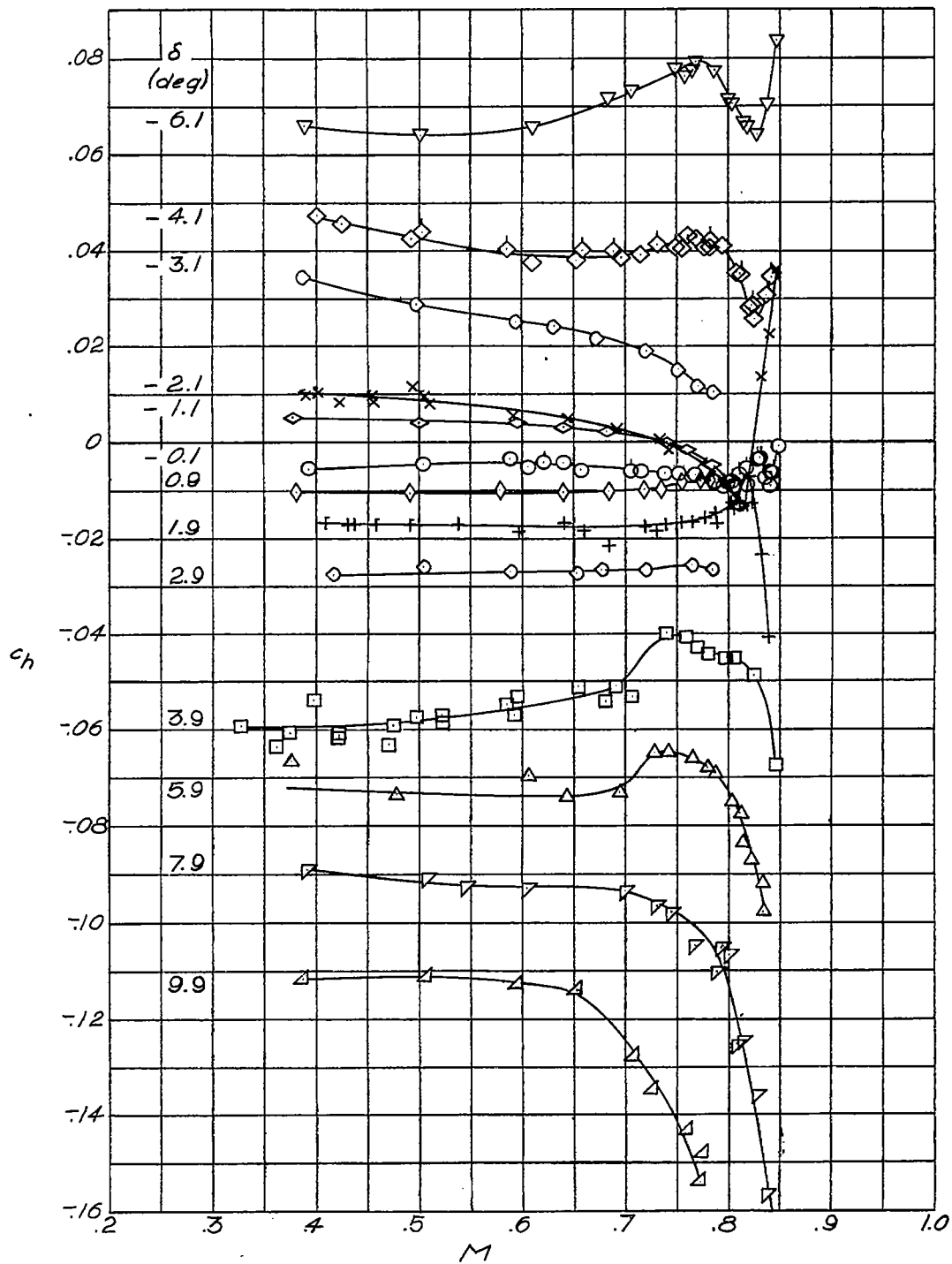
Figure 13. - Variation of flap section hinge-moment coefficient with Mach number.



(b) $\alpha = -2^\circ$

NATIONAL ADVISORY
COMMITTEE FOR AERONAUTICS

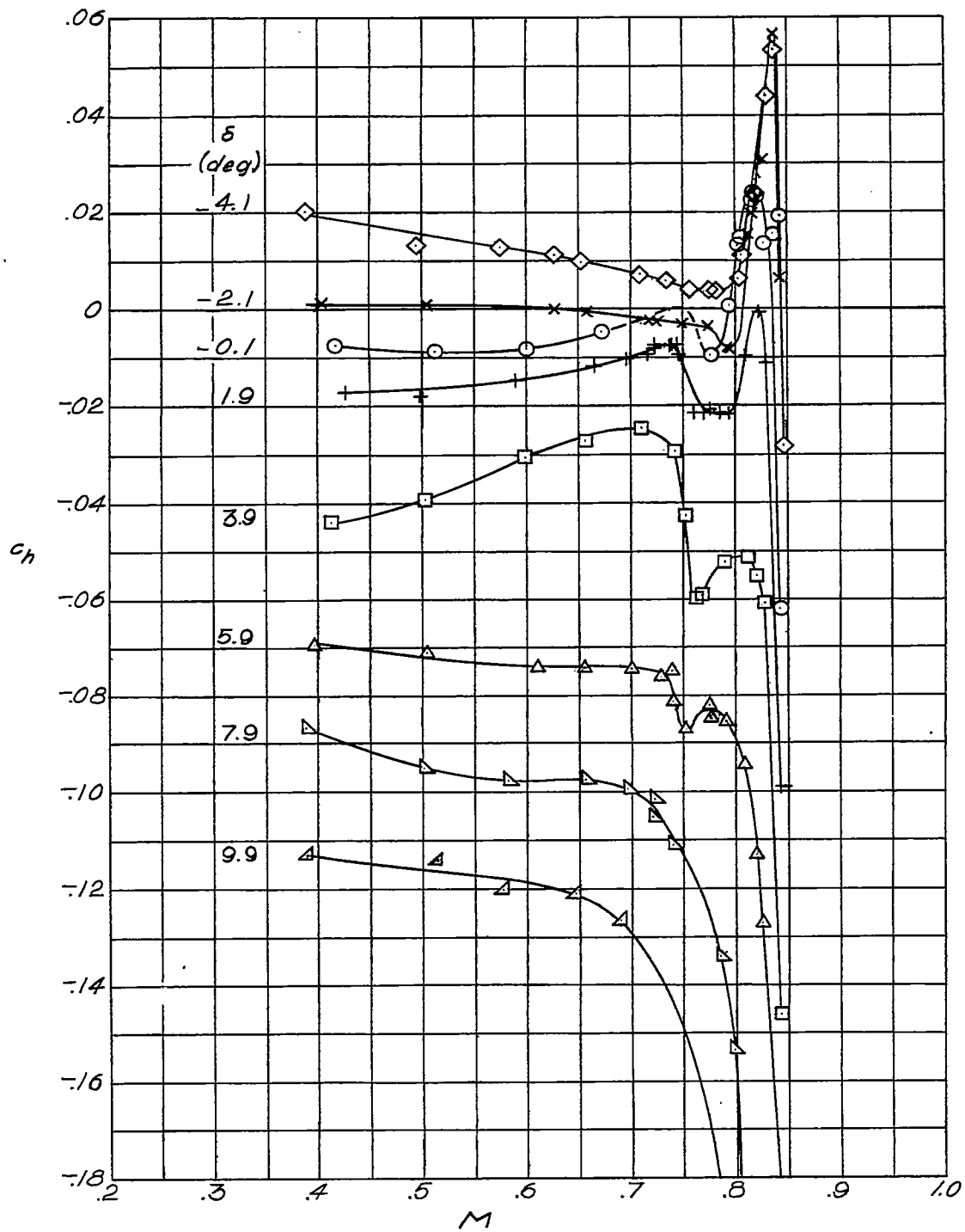
Figure 13. - Continued.



(c) $\alpha = 0^\circ$.

NATIONAL ADVISORY
COMMITTEE FOR AERONAUTICS

Figure 13. - Continued.



(d) $\alpha = 2^\circ$.

NATIONAL ADVISORY
COMMITTEE FOR AERONAUTICS

Figure 13. - Concluded.

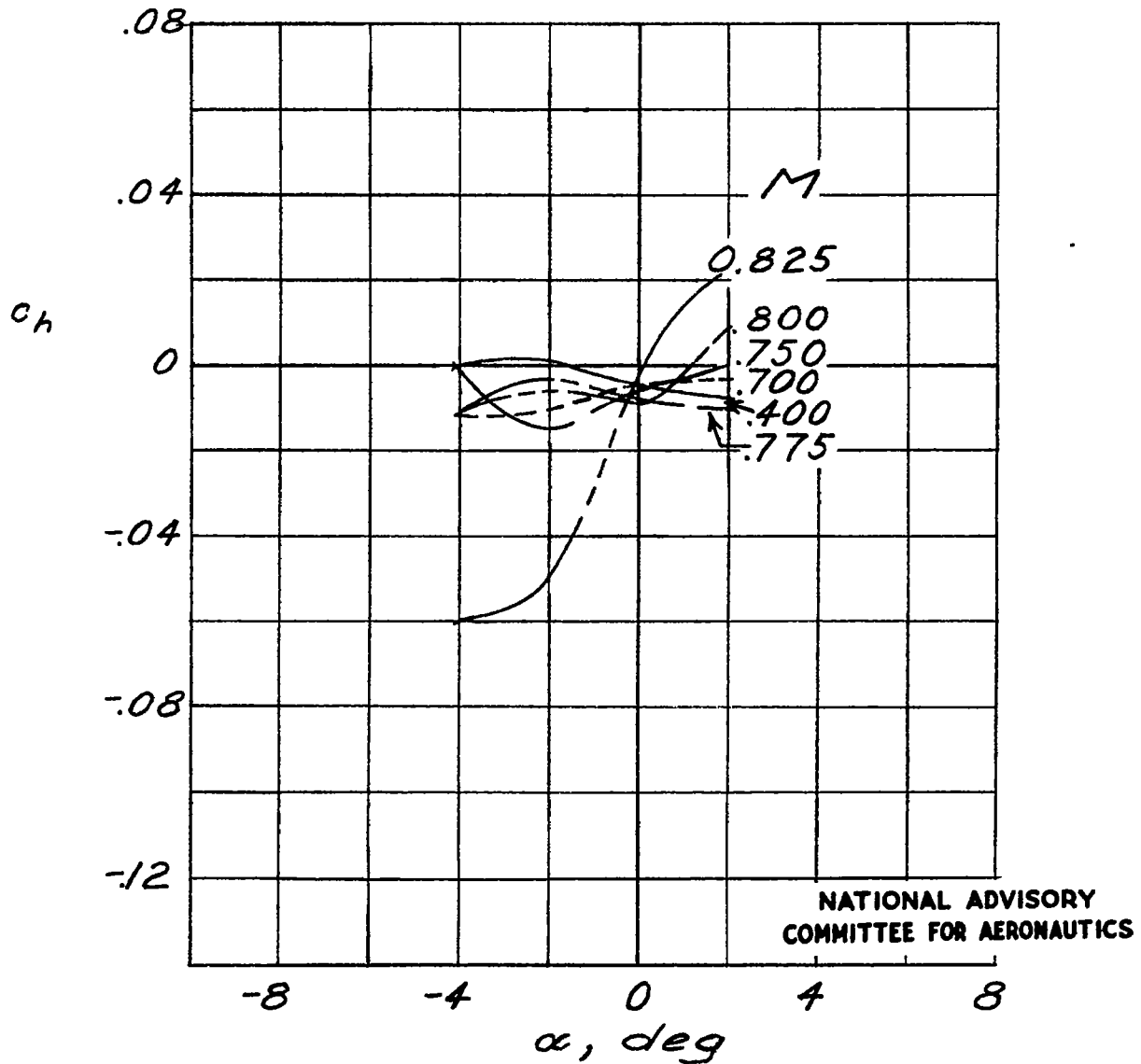
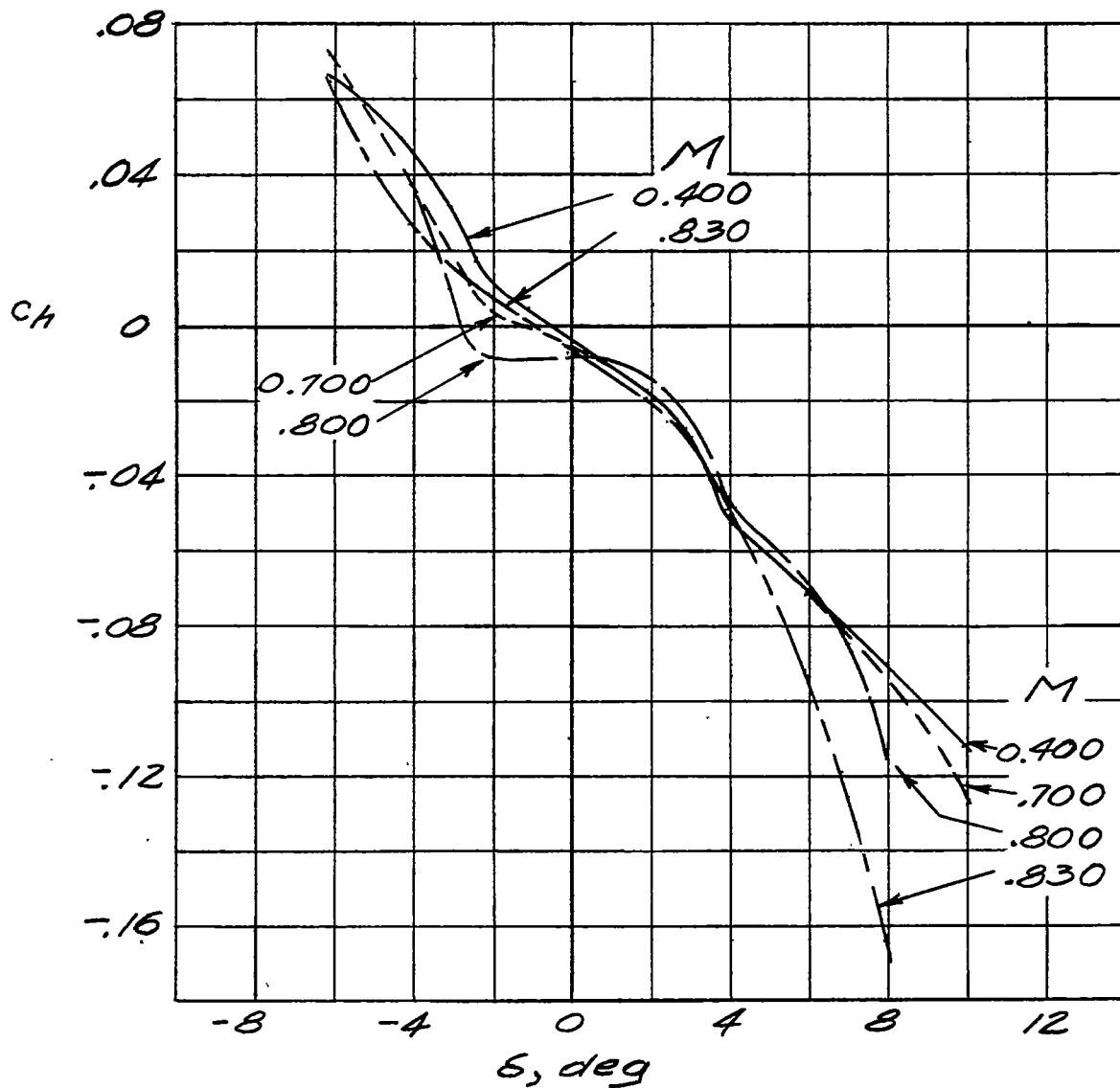


Figure 14. - Variation of flap section hinge-moment coefficient with angle of attack.
 $\delta = -0.1^\circ$



NATIONAL ADVISORY
COMMITTEE FOR AERONAUTICS

Figure 15.- Variation of flap section hinge-moment coefficient with flap deflection. $\alpha = 0^\circ$.

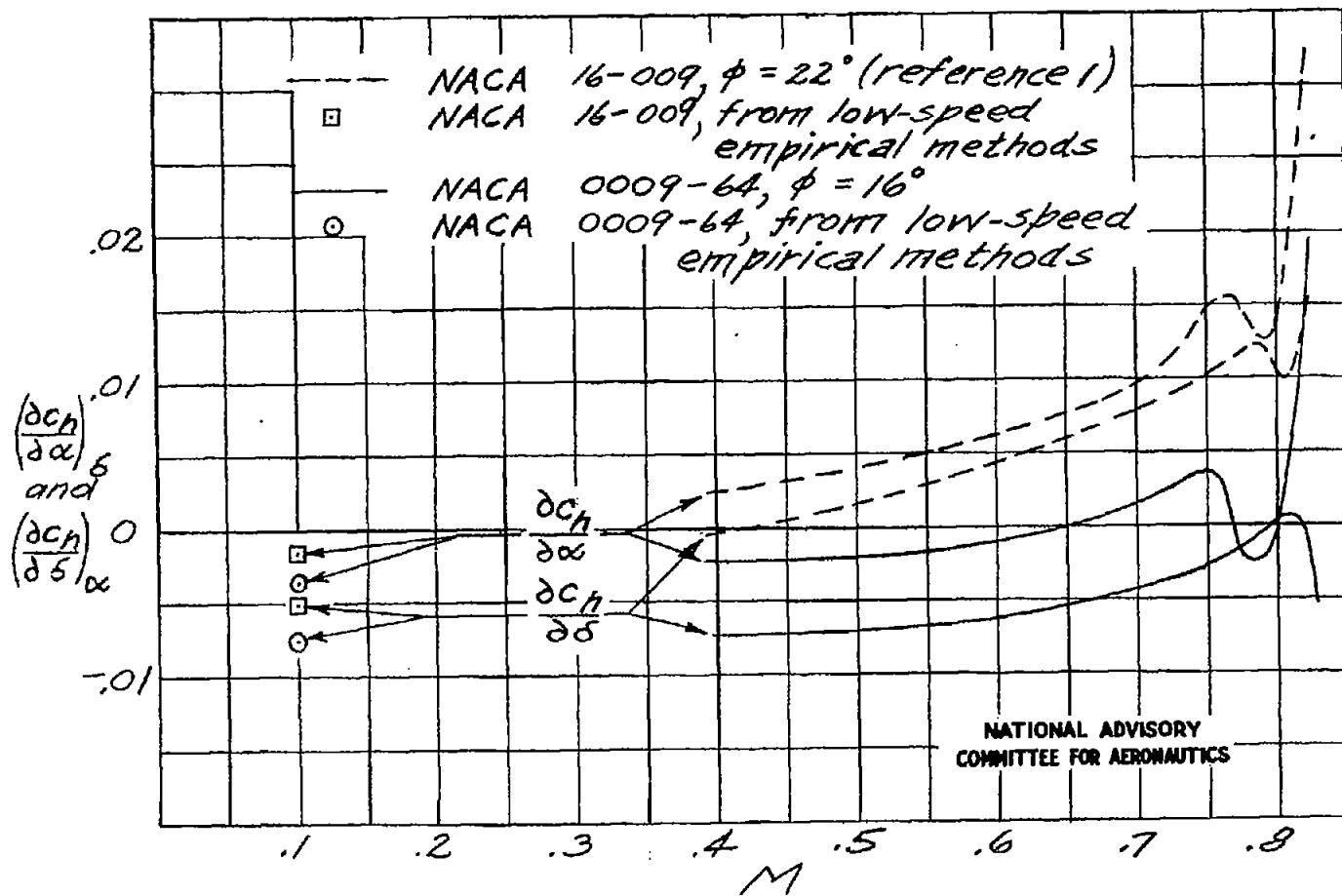


Figure 16. - Variation of hinge-moment parameters with Mach number.
 $\alpha = 0^\circ$; $\delta = -0.1^\circ$

TITLE: High-Speed Wind-Tunnel Tests of an NACA 0009-64 Airfoil having a 33.4-Percent Chord Flap With an Overhang 20.1 Percent of the Flap Chord

AUTHOR(S) : Stevenson, D. B.; Adler, Alfred A.

ORIG. AGENCY : Langley Memorial Aeronautical Laboratory, Langley Field, Va.

PUBLISHED BY : National Advisory Committee for Aeronautics, Washington, D. C.

ATI- 11595

DIVISION
(None)

ORIG. AGENCY NO.

TN-1417

PUBLISHED NO.

(Sams)

DATE
Sep '47

U. S. CLASS
Unclass.

COUNTRY
U.S.

LANGUAGE
English

PAGES
33

ILLUSTRATIONS
photos, graphs, drwg

ABSTRACT:

Tests were conducted to investigate compressibility effects on NACA 0009-64 airfoil and to determine the airfoil lift, pitching moment, and flap hinge moment for various flap angles, angles of attack, and Mach number. Results showed that the flap effectiveness generally decreased with an increase in Mach number. The rate of change of hinge-moment coefficient with both angles of attack and flap deflection became more positive with increases in Mach number in the supercritical speed range.

DISTRIBUTION: All requests for copies must be addressed to Publishing Agency.

DIVISION: Aerodynamics (2)

SECTION: Wings and Airfoil (6)

SUBJECT HEADINGS:

Airfoils - Aerodynamics (07710)

Airfoils - Compressibility effects (08032)

Flaps - Effectiveness (37451.3)

ATI SHEET NO.:

Central Air Documents Office
Wright-Patterson Air Force Base, Dayton, Ohio

AIR TECHNICAL INDEX