

MAY 12 1947

120717
NACA/

NATIONAL ADVISORY COMMITTEE FOR AERONAUTICS

WARTIME REPORT

ORIGINALLY ISSUED

November 1942 as
Advance Restricted Report

FLIGHT INVESTIGATION OF AN NACA ICE-DETECTOR SUITABLE
FOR USE AS A RATE-OF-ICING INDICATOR

By R. R. Gilruth, J. A. Zalovcik, and A. R. Jones

Langley Memorial Aeronautical Laboratory
Langley Field, Va.

NACA

WASHINGTON

NACA WARTIME REPORTS are reprints of papers originally issued to provide rapid distribution of advance research results to an authorized group requiring them for the war effort. They were previously held under a security status but are now unclassified. Some of these reports were not technically edited. All have been reproduced without change in order to expedite general distribution.



3 1176 01403 4475

NATIONAL ADVISORY COMMITTEE FOR AERONAUTICS**ADVANCE RESTRICTED REPORT****FLIGHT INVESTIGATION OF AN NACA ICE-DETECTOR SUITABLE
FOR USE AS A RATE-OF-ICING INDICATOR**

By R. R. Gilruth, J. A. Zalovecik, and A. R. Jones

SUMMARY

An ice detector, which serves as a basis for a rate-of-icing indicator, has been developed and tested recently by the National Advisory Committee for Aeronautics. This instrument consists primarily of a wire screen and a pitot tube mounted some distance behind the screen; both are enclosed in a cylindrical shell. In operation under icing conditions, the pitot tube measures a total pressure that decreases progressively as ice accumulates on the wire screen ahead of it.

The present investigation has disclosed two important characteristics of this instrument, either of which can be utilized in measuring the rate of icing. It has been found that (a) the time required for the pressure to drop from any given level to another given level is inversely proportional to the icing rate, and (b) the maximum rate of change of pressure or the average rate of change of pressure is proportional to the rate of icing.

INTRODUCTION

At the present time, several indicators are available that are used to detect the presence of ice on aircraft in flight. The primary purpose of such instruments is to insure either by direct or indirect means that the de-icing equipment of the airplane is set in operation at the proper time. The desirability of a device to indicate not only the presence of ice but also the rate of ice formation has been repeatedly expressed by interested persons and agencies. The Army, the Navy, and the air-line operators advance varying opinions on the probable usefulness of such an instrument, but all agree that the device should be developed. Meteorologists have been particularly interested in the project

as a source of fundamental information for the correlation of atmospheric conditions with the actual rates of icing incurred.

Because of the demand for a rate-of-icing indicator, the NACA, as part of its general research on icing, has given consideration to various designs that have been proposed from time to time during the past few years and has tested some of them in flight. Most of these devices have shown so little promise that a very brief investigation has been sufficient to disclose inherent weaknesses in the designs. A brief review of these previously unreported investigations is given as an appendix to the present report.

A recent development by the NACA, however, has shown considerable promise of providing a satisfactory solution to the problem and is undergoing further development. This device, termed the "rate-of-icing head," when used in conjunction with an instrument that indicates the pressure variations experienced by the head will provide a measure of the icing rate.

The primary purpose of this report is to describe this rate-of-icing head, the theory of its operation, and the results of flight tests under simulated icing conditions.

APPARATUS AND TESTS

The rate-of-icing head, recently developed and tested by the NACA at Langley Field, Va., is shown schematically in figure 1. It consists principally of a cylindrical shell with a wire screen at the upstream end and a pitot tube inserted into the downstream end. The wire screen was made by lacing a continuous piece of nichrome wire back and forth across the shell entrance and then connecting it in series with an electrical circuit so as to allow the flow of an electric current whenever necessary to heat the screen and, consequently, de-ice it. The pitot tube was provided with a baffled chamber from which a pressure lead was taken and from which a hole at the bottom allowed drainage of any entrained moisture. The cylindrical shell and the pitot tube were equipped with heater elements for de-icing of those parts. A photograph of a rate-of-icing head is shown in figure 2.

The rate-of-icing head was tested in flight on a Stinson Reliant, a high-wing, single-engine monoplane. The

head was mounted near the fuselage on a strut supported from the baggage compartment. A water-spray system was used to control the moisture content of the air for the simulated icing conditions under which the rate-of-icing head was tested. The apparatus for this system consisted of two air-water nozzles mounted on a strut ahead of the rate-of-icing head, a water pump driven by an electric motor whose speed was regulated by means of a rheostat, a water tank, and a compressed-air cylinder. The air and water lines leading from the compressed-air cylinder and the water pump, respectively, were each connected to a mercury manometer so that the pressure in each could be adjusted to a desired level.

During the flight tests, the following procedure was followed. All the tests were made in level flight at a constant speed and at altitudes at which the air temperature was between 26° and 28° F. A given spray density was maintained throughout a given test run by adjusting the pressure in the water and air lines leading to the spray nozzles. As the screen of the rate-of-icing head accumulated ice, the rate of decrease of total pressure (referred to cockpit static pressure) in the head was observed by means of a stop watch and a pressure indicator. The icing rate corresponding to the spray density used in a particular run was determined for a streamline tube (major axis 1.52 in.) by exposing it to the spray for a given period of time and then measuring the amount of ice built up. This procedure not only gave an indication of the rate of icing but also provided a partial calibration of the instrument.

THEORY OF RATE-OF-ICING HEAD

In the analysis of the data, it is first desirable to discuss the physical processes involved in the operation of the rate-of-icing head.

The rate-of-icing head operates as a rate-of-icing indicator on the basis of increasing pressure loss due to a continually decreasing opening in the screen as a result of ice accretion. In the development of the theory, each pair of adjacent segments of the wires of the screen are considered to form an orifice, as is shown in figure 3. The pressure loss in the rate-of-

icing head between sections 1 and 3 caused by the orifice effect of the wires can be shown to be

$$\frac{\Delta P}{q} = \frac{\left(\frac{A_1}{\alpha A_2} - 1\right)^2}{1 + \left(\frac{A_1}{\alpha A_2} - 1\right)^2}$$

where

- ΔP pressure loss
 q dynamic pressure in rate-of-icing head without screen
 A_1 cross-sectional area of the opening of the rate-of-icing head
 A_2 cross-sectional area of screen opening
 α coefficient of contraction, which will be assumed to be unity

Let

$$A_2 = A_1 - Ld$$

where

- d diameter of wire, inches
 L total length of wire exposed

then

$$\frac{\Delta P}{q} = \frac{\left(\frac{A_1}{A_1 - Ld} - 1\right)^2}{1 + \left(\frac{A_1}{A_1 - Ld} - 1\right)^2} \quad (1)$$

In terms of free-stream dynamic pressure q_0 , the pressure loss can be written as:

$$\frac{\Delta P}{q_0} = \frac{\Delta P}{q} \times \frac{q}{q_0}$$

In the determination of the variation of $\Delta p/q$ with time, the increase in diameter of the wire for a given icing rate is assumed to be proportional to time, as

$$d_t = d_o + Kit \quad (2)$$

where

- d_t diameter of wire at any time t . (in sec)
- d_o initial or uniced diameter of wire, inches
- I icing rate on leading edge of streamline tube, inches per second
- K constant of proportionality relating the icing rate on the leading edge of a streamline tube to that on the diameter (normal to air stream) of a wire

The order of magnitude of K in equation (2) may be seen to be roughly 2 by assuming that as much ice forms on each side of the wire as forms on the leading edge of a streamline tube per unit time. Actually, a value of $K = 2.2$ fits the experimental data better.

RESULTS AND DISCUSSION

The results of tests of the rate-of-icing head are presented in table I, in which the observed data are tabulated giving the time t' required for the total pressure H_1 in the rate-of-icing head, measured relative to the cockpit static pressure, to drop from a pressure of 4.00 inches of water to the given pressures for three different icing rates. It should be pointed out that the initial value of the pressure given by the rate-of-icing head was 4.45 inches of water so that some ice had accumulated on the screen before the 4 inches of water pressure was reached. The elapsed time t' in table I therefore represents the relative time intervals for the observations at each icing rate but not the absolute time. The data listed in table I are also presented graphically in subsequent figures.

TABLE I
OBSERVED DATA

I = 0.03 in./min		I = 0.05 in./min		I = 0.08 in./min	
H_i (in. water)	t' (sec)	H_i (in. water)	t' (sec)	H_i (in. water)	t' (sec)
4.00	0	4.00	0	4.00	0
3.15	11	3.15	7	3.15	4
3.15	12				
2.40	19	2.40	11		
1.80	25	1.80	16		
1.25	30	1.25	20		
.80	36	.80	24	.80	12
.80	38				

Equations (1) and (2) indicate that a valid comparison of the data at the various icing rates presented in table I can be made only on the basis of absolute time. A correction must therefore be applied to the elapsed time t' by adding to it the time interval required for the dynamic pressure in the rate-of-icing head to drop from an initial value of 4.45 inches of water to 4.00 inches of water. The correction Δt , in seconds, can be shown to be

$$\Delta t = \frac{0.016}{KI}$$

and the absolute time t , in seconds

$$t = t' + \frac{0.016}{KI}$$

When this correction to the elapsed time had been made and the pressure variation was changed to a non-dimensional form, the results shown in figure 4 were obtained. Calculated values of pressure variation with time are also included in figure 4. It may be seen that the calculated curves are in good agreement with the experimental points. The most important characteristic to be noted of this rate-of-icing head is that the time

required for the pressure to drop to a given level is inversely proportional to the icing rate as is also the time required for the pressure to drop from any given level to another given level. Other characteristics can be investigated by further examining equations (1) and (2).

Four additional characteristics, somewhat related to the one noted, appear if equations (1) and (2) are differentiated with respect to time, combined, and the corresponding evaluation for the three icing rates is plotted as in figure 5. The rate of icing may be seen in figures 5 and 6 to be (1) proportional to the maximum rate of change of pressure, (2) proportional to the average rate of change of pressure, (3) inversely proportional to the time required for the rate of change of pressure to attain a maximum value, and (4) inversely proportional to the time required for the rate of change of pressure to drop from its maximum value to zero.

The utilization of some of these operational characteristics will be further illustrated. Consider the rate-of-icing indicator schematically drawn in figure 7 with the pitot tube in the rate-of-icing head connected to a pressure indicator for which the reference is the free-stream total pressure.

A typical pressure-loss curve, as obtained with this rate-of-icing head, is shown in figure 8 for a given free-stream velocity and a given icing rate. The pressure loss registered by the pressure indicator will be made up of the initial pressure loss due to the presence of the uniced wire screen and the pressure loss due to ice accretion on the screen. For the arrangement and size of wires used in the rate of icing head tested, the pressure loss due to the uniced wire screen was calculated to be about 2 percent of local dynamic pressure. It will be seen from this result that the position of the needle on the pressure indicator for the uniced condition of the screen will vary with speed, the deviation from zero being about 2 percent of local dynamic pressure. If the pressure loss Δp_1 due to ice accretion is timed as in figure 8 from point a, corresponding to the uniced condition of the screen, to any point such as b, the rate of ice formation can be easily determined, since

$$I = K_1 \left(\frac{\Delta p_1}{t} \right)$$

Figure 9 represents a typical curve for a given velocity showing how the time required for the pressure to drop a fixed amount Δp_1 from a pressure level corresponding to the uniced condition of the screen, varies with the rate of icing. For velocities different from that for which curves in figures 8 and 9 were drawn, the time required for the pressure to drop a fixed amount Δp_1 will vary inversely as the local dynamic pressure. This variation for a given icing rate is shown in figure 10. With a suitable arrangement of pressure diaphragms, stop watch, and an electrical circuit, the indication of rate of icing may be made practically automatic and independent of speed.

Another characteristic of the rate-of-icing head investigated may be used if the instrument employed is capable of measuring small changes in pressure Δp in small intervals of time Δt (see fig. 8), that is, the rate of change of pressure. The maximum rate at which Δp changes with respect to Δt can be used as a measure of the rate of icing because the icing rate was previously shown to be proportional to the maximum rate of change of pressure. An instrument that would measure the rate of change of pressure and, consequently, the icing rate, could be constructed on the same principle as a rate-of-climb meter and could also be made independent of speed, variation in speed, and variation in altitude. An electrical circuit consisting of an ammeter and a variable condenser controlled by the pressure variation in the rate-of-icing head and subjected to a fixed potential could also be used to measure indirectly the rate of change of pressure by measuring the induced current. If, instead of an ammeter in such a circuit, an integrating device were used, the average rate of change of pressure thus obtained could be used as a measure of the rate of icing.

FUTURE DEVELOPMENTS

Although tests conducted thus far have indicated that the rate-of-icing head as designed has been repeatedly consistent in its behavior, it is believed that considerable improvement can be obtained by modifications now being investigated. One of these modifications consists in replacing the pitot tube with two static-pressure orifices, one ahead of and one behind the screen, with the

result that considerable simplification and reduction in size of the rate-of-icing head will be achieved. (See fig. 11.) Such an arrangement is of particular advantage in that there is no need to refer any pressure in the head to any pressure external to the installation as must be done in the case of the head with the pitot tube. This simplified arrangement would also materially reduce the electrical heating required for the body and the support of the device. As may be seen from theory, the pressure drop across the screen as measured with the two static-pressure orifices should be practically the same as that registered by the pitot tube with the result that no change in the operational characteristics previously discussed is to be expected.

Another modification under consideration consists in using a rotating screen in a properly designed head in order that a continuous indication of the rate of icing may be had instead of the intermittent indication now possible with the fixed-screen type of rate-of-icing head. In such an instrument only a portion of the rotating screen would be exposed; the rest is protected and continuously de-iced. With the screen rotating at a constant rate the amount of ice accumulating on the exposed portion of the screen is expected to be constant for a given rate of icing and the pressure drop across the exposed portion of the screen to be a measure of the rate of icing. For such an instrument a rate indicator would consist simply of a pressure indicator calibrated for the icing rate.

The use of the rate-of-icing head solely as an ice indicator, for which it is particularly well adapted, should find greater application than its use as a rate indicator. The pressure leads from the static-pressure orifices may be connected to a pressure diaphragm (see fig. 12) that can be adjusted to complete an electrical circuit for the operation of a warning device or for the operation of the de-icing equipment.

CONCLUSIONS

From the experimental data and the theory of the rate-of-icing head, it may be concluded that the instrument designed at the NACA is capable of measuring the

rate of icing. Two important operational characteristics of the instrument have been found, either of which may be utilized in measuring the rate of icing:

1. The time required for the pressure in the rate-of-icing head to drop from any given level to another given level is inversely proportional to the icing rate.

2. The maximum rate of change of pressure or the average rate of change of pressure is proportional to the icing rate.

Langley Memorial Aeronautical Laboratory,
National Advisory Committee for Aeronautics,
Langley Field, Va.

APPENDIX

TESTS OF OTHER DEVICES INTENDED TO BE USED AS RATE-OF-ICING INDICATORS

The various devices proposed as rate-of-icing indicators from time to time are shown in figures 13 through 18.

The indicator A in figures 13 and 14 consisted of four tubes, each of which was hooked at one end and welded to a common header at the other end. This device was intended to operate as a rate-of-icing indicator by having ice build up on the header and out toward the hooked tubes, sealing each of the tubes in succession as the ice formation increased in size. The rate of ice formation was to be determined by timing the sealing of successive tube openings and knowing the distance between the tube openings. Figure 12 shows that the manner in which ice formed on the tubes under simulated icing conditions rendered this device useless as a rate-of-icing indicator.

The indicator B shown in figures 15 and 16 consisted of a 1/4-inch rod, 6 inches long, welded perpendicularly to a 3-inch-diameter disk, and mounted with

the rod pointing into the air stream. The depth of the ice formation on the disk was to be determined by means of alternate black-and-white-color bands each $\frac{1}{8}$ inch wide. The rate of ice formation would presumably be calculated if the time required for the formation of the depth of ice accumulated on the disk was noted. From figure 16 it may be seen that the accumulation of ice in the rod precludes the use of this arrangement of rod and disk as a means of measuring the rate of icing.

Indicator C shown in figure 17 was patterned after a successful ice detector, which operated on the principle that ice formation would seal the three holes directed upstream causing the pressure in the indicator to drop to a static-pressure level produced by the rearward drain hole. The conversion of the ice detector to a rate-of-icing indicator was based on the assumption that the sealing of the three holes would be accomplished at a rate depending on the degree of icing present.

A somewhat similar device, indicator D shown in figure 18, was also intended to operate as a rate-of-icing indicator on the same principle. A brief examination of these designs was sufficient to disclose the fact that they would not operate as rate-of-icing indicators inasmuch as the pressure registered would remain total pressure (except for the loss resulting from the flow of air through the drain hole) until the forward holes were entirely sealed. Tests of these devices confirmed the foregoing conclusion and, in addition, showed that a considerable amount of ice could accumulate on the heads without sealing off the openings.

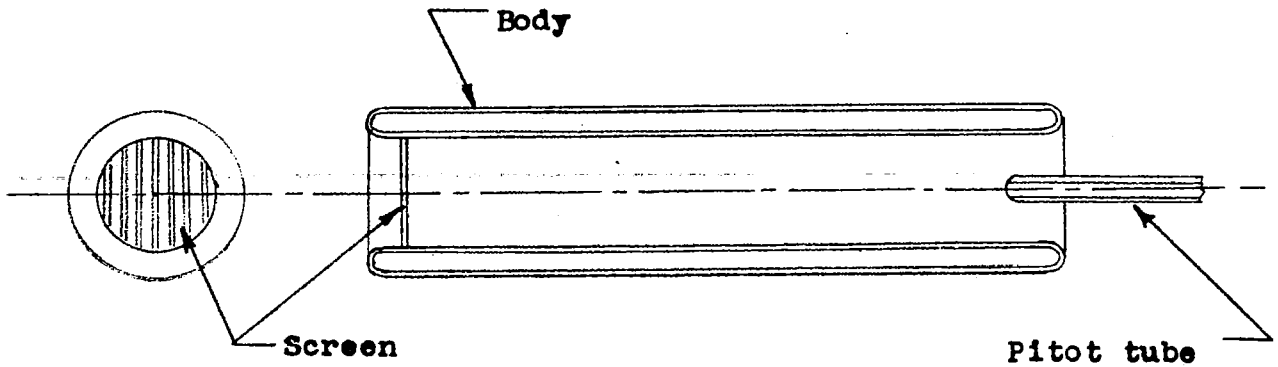

Figure 1.- Schematic drawing of rate-of-icing head.

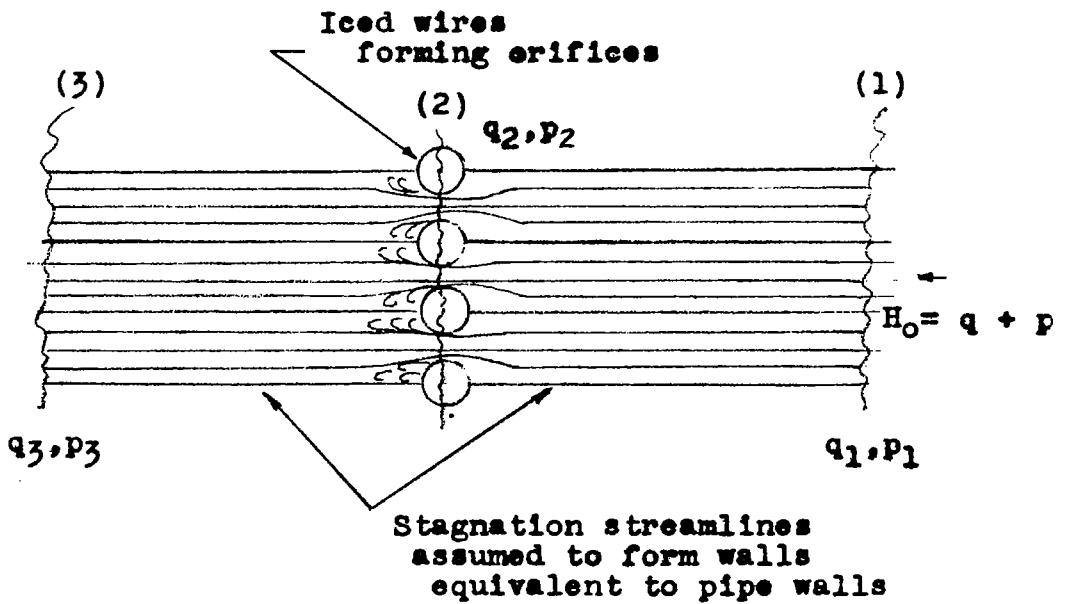

Figure 3.- Orifices formed by iced wire screen of rate-of-icing head.

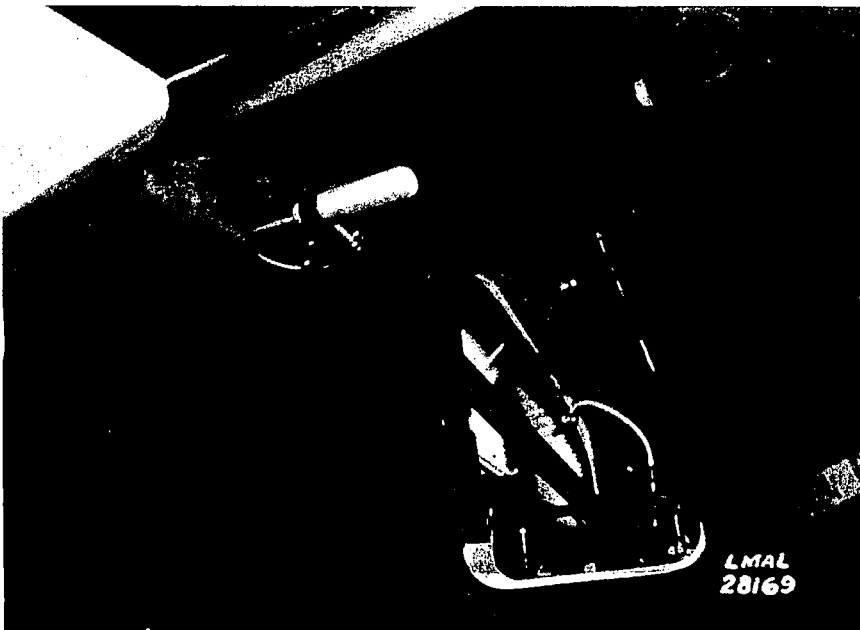
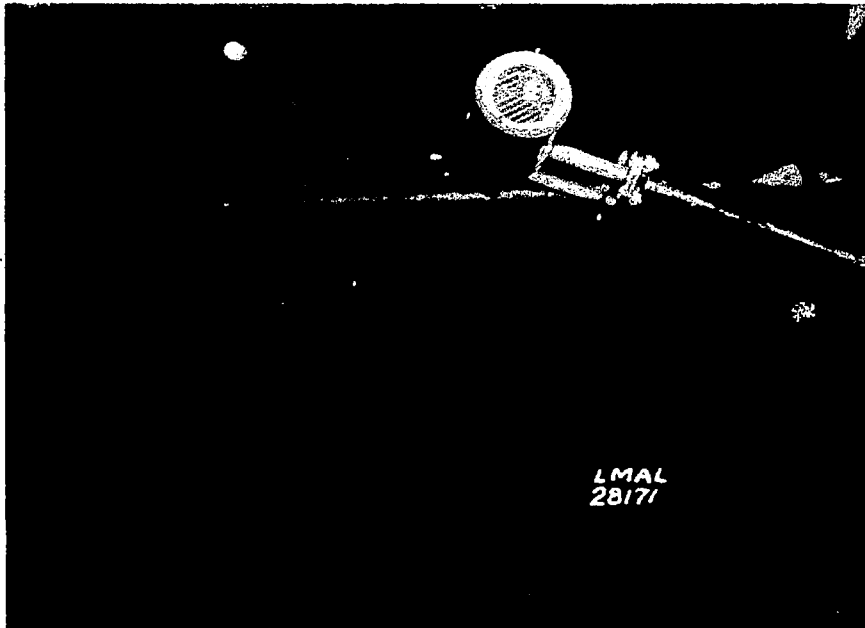

FIGURE 2.- RATE-OF-ICING HEAD.

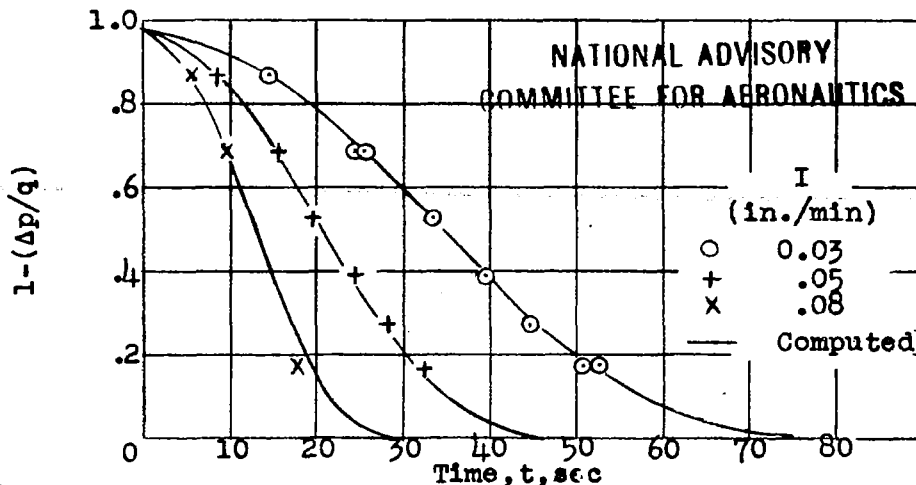

Figure 4.- Variation of pressure in rate-of-icing head as a function of time for three icing rates.

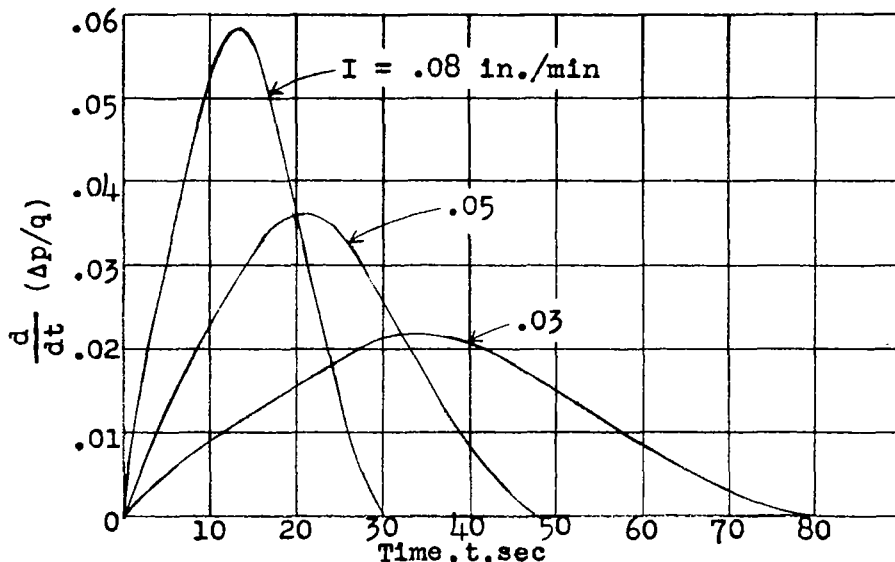

Figure 5.- Rate of change of pressure in rate-of-icing head as a function of time for three icing rates.

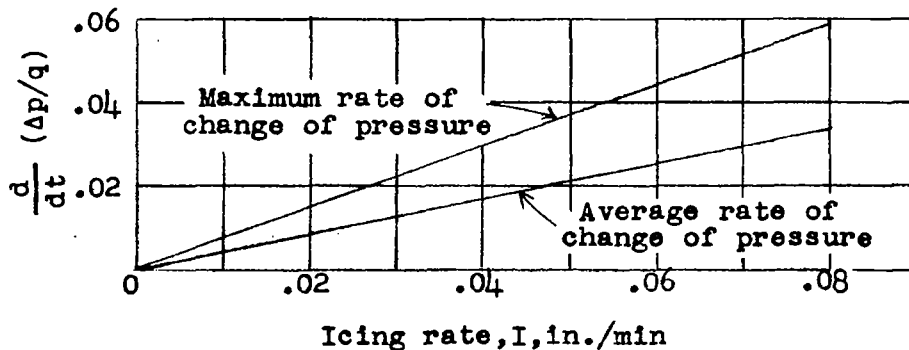

Figure 6.- Variation of the maximum rate of change of pressure and average rate of change of pressure with icing rate.

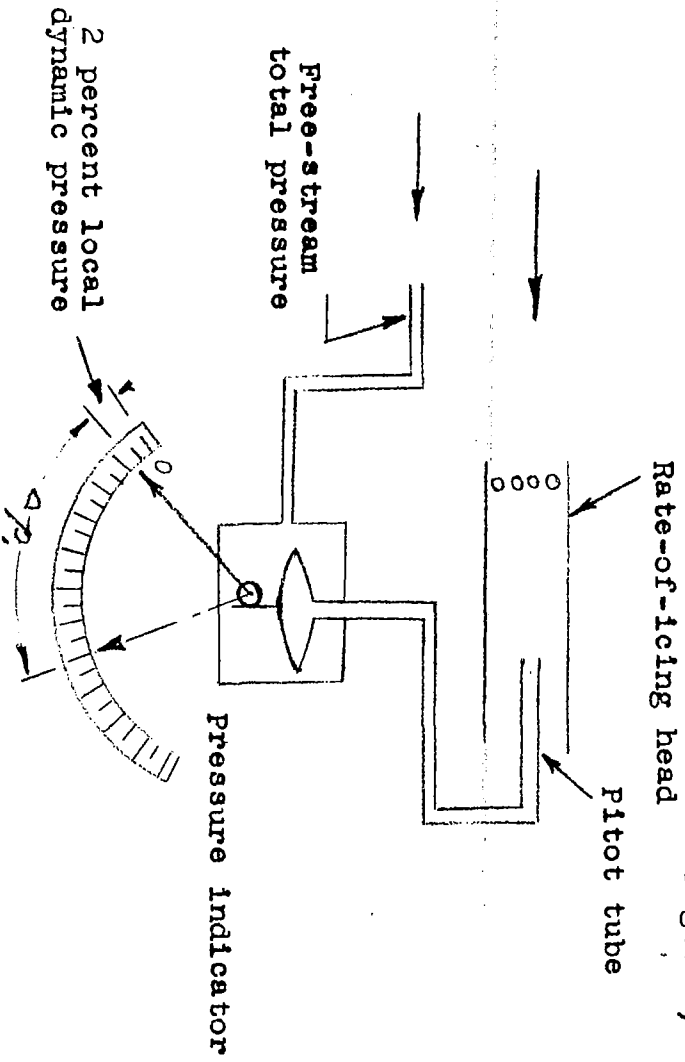

Figure 7.- Schematic drawing of rate-of-icing head and pressure connections.

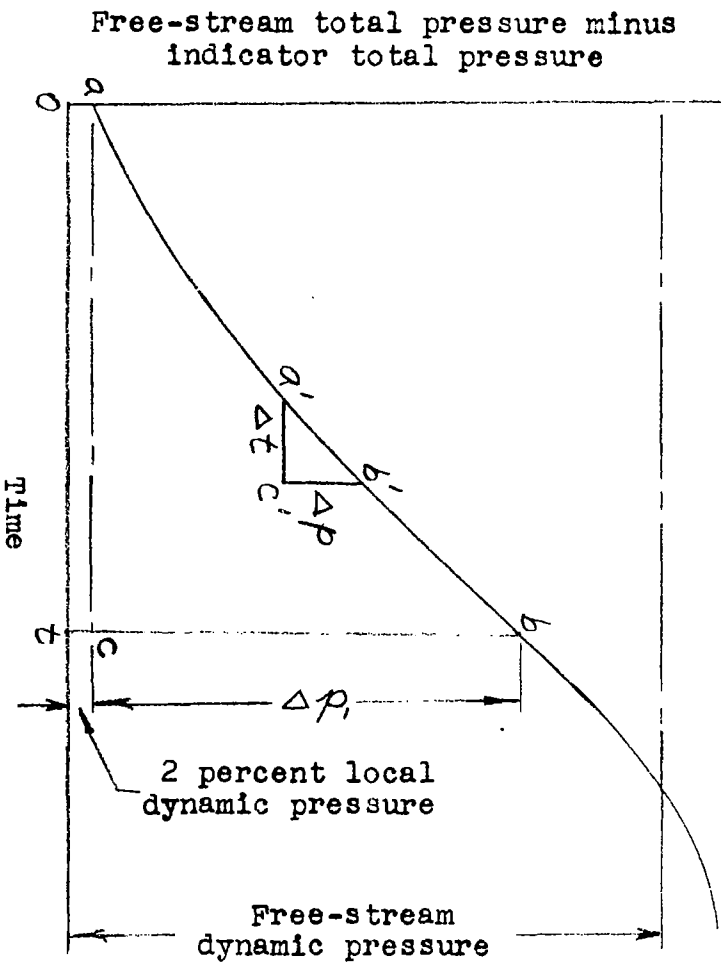

Figure 8.- Typical pressure-loss curve for given free-stream velocity and given icing rate.

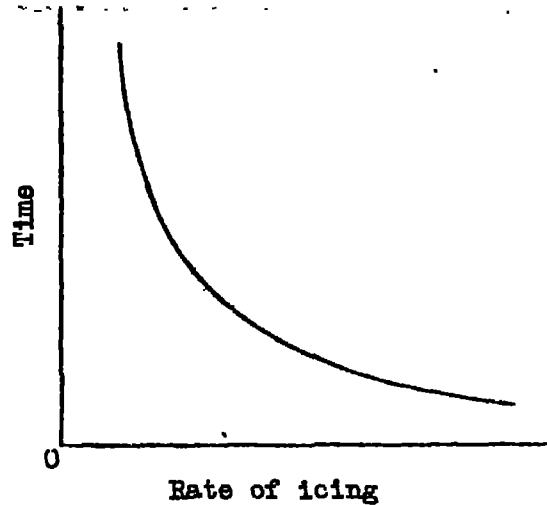

Figure 9,- Time required for a given pressure drop Δp_1 at a given speed as a function of rate of icing.

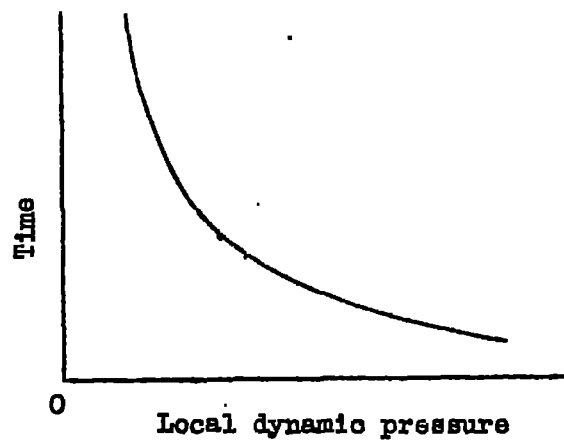

Figure 10,- Time required for a given pressure drop Δp_1 at a given rate of icing for various speeds.

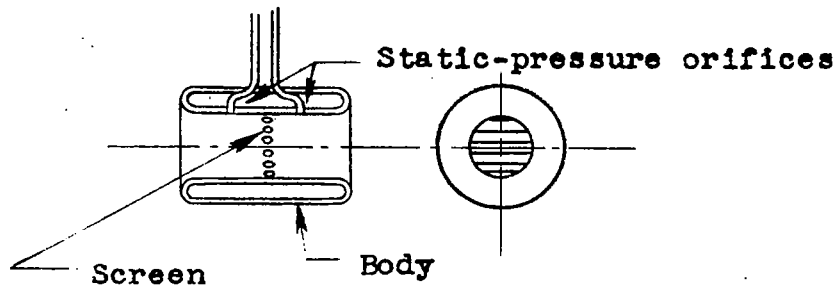

Figure 11.- Sketch of proposed rate-of-icing head with static-pressure orifices replacing pitot tube.

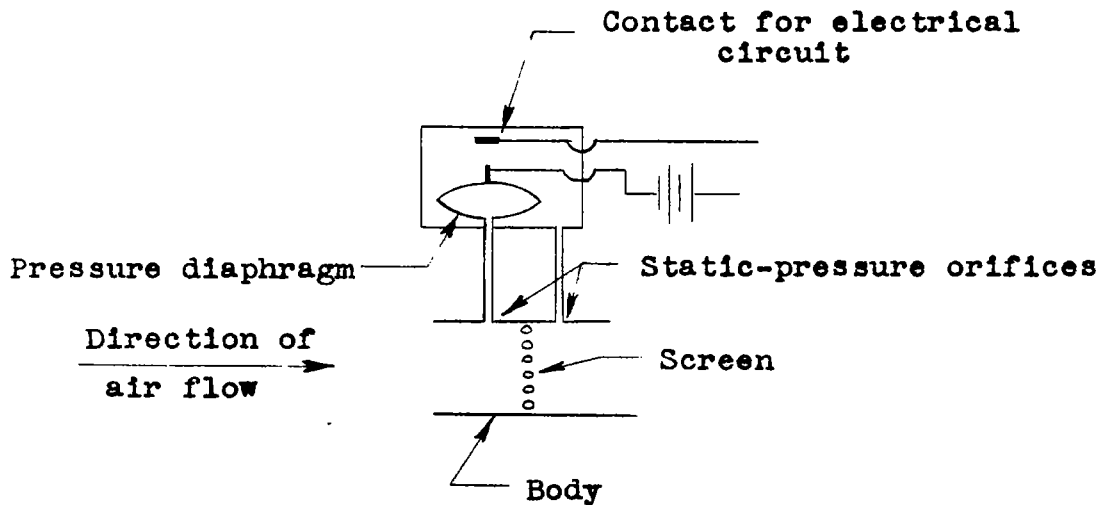

Figure 12.- Proposed schematic diagram of rate-of-icing head used as an ice detector.

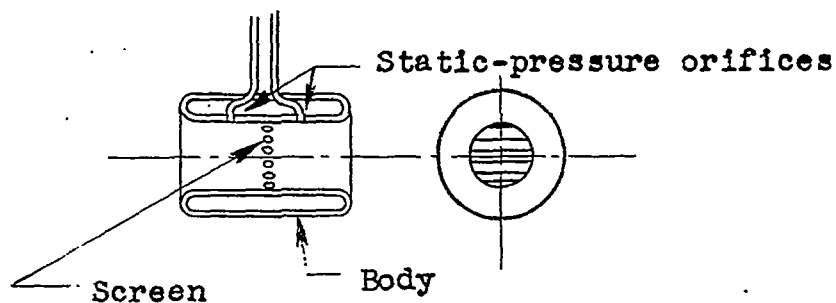

Figure 11.- Sketch of proposed rate-of-icing head with static-pressure orifices replacing pitot tube.

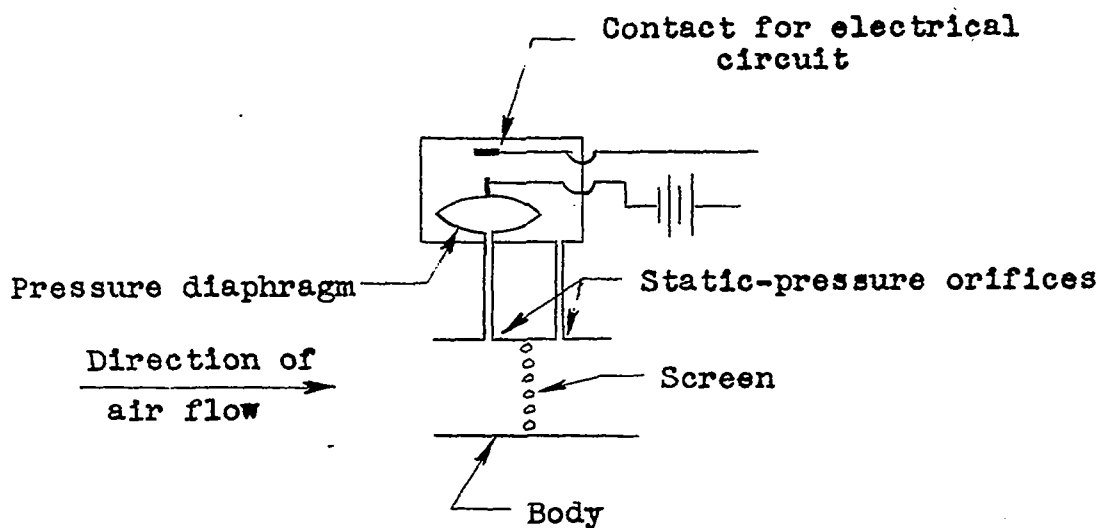

Figure 12.- Proposed schematic diagram of rate-of-icing head used as an ice detector.

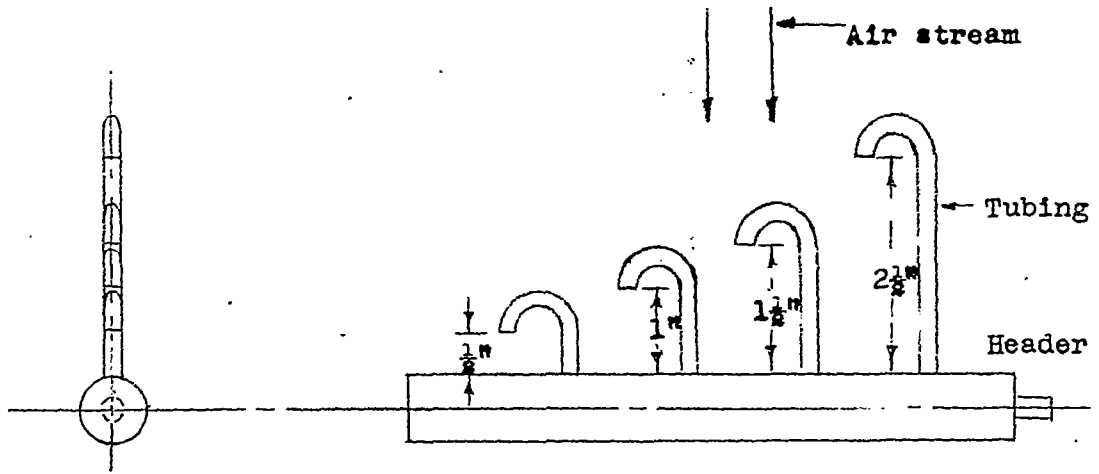

Figure 13.- Rate-of-icing indicator A.

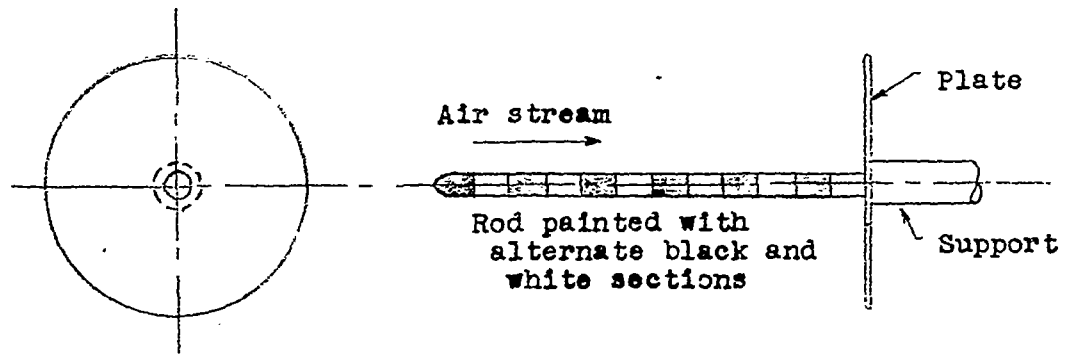

Figure 15.- Rate-of-icing indicator B.

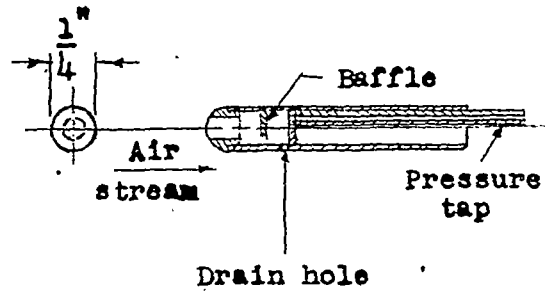
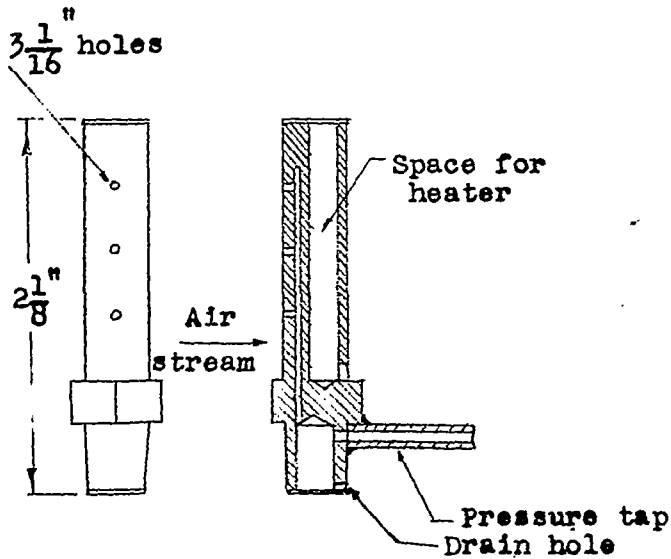

Figure 17.- Rate-of-icing indicator C. Figure 18.- Rate-of-icing indicator D.

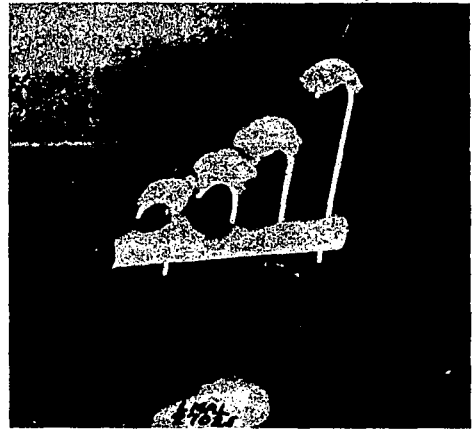

FIGURE 14- ICE ACCRETION ON INDICATOR A. NOTE THAT ICE ACCUMULATIONS ON ENDS OF TUBES ACT AS SHIELD FOR HEADER.

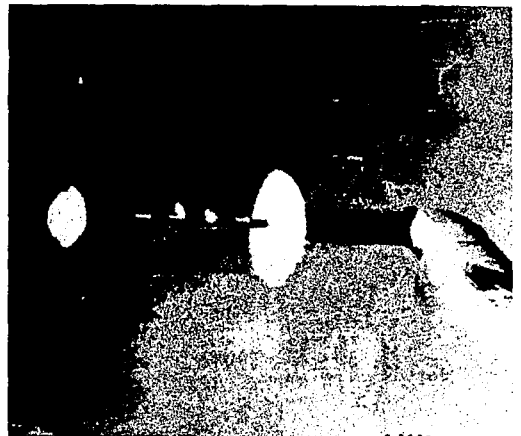

FIGURE 16.- ICE FORMATION ON INDICATOR B. LARGE ACCUMULATION OF ICE ON END OF ROD ACTS AS SHIELD FOR DISK.
I.M. 2° 737

TITLE: Flight Investigation of an NACA Ice-Detector Suitable for Use as a Rate-of-Icing Indicator

AUTHOR(S) : Gilruth, R. R.; Zalovcik, J. A.; Jones, A. R.; and others
ORIG. AGENCY : National Advisory Committee for Aeronautics, Washington, D. C.
PUBLISHED BY : (Same)

ATI- 7920

REVISION

(None)

ORIG. AGENCY NO.

ARR-1-364

PUBLISHING NO.

(Same)

DATE	U.S. CLASS	COUNTRY	LANGUAGE	PAGES	ILLUSTRATIONS
Nov '42	Unclass.	U.S.	English	19	photos, table, diagr, graphs

ABSTRACT:

Instrument consists primarily of wire screen and pitot tube enclosed in cylindrical shell. In operation under icing conditions, pitot tube measures total pressure that decreases progressively as ice accumulates on wire screen ahead of it. Investigation disclosed that time required for pressure to drop from any given level to another given level is inversely proportional to icing rate, and maximum or average rate of change of pressure is proportional to rate of icing.

DISTRIBUTION: All requests for copies must be addressed to Originating Agency.

DIVISION: Operating Problems (31) /
SECTION: Icing (1)

SUBJECT HEADINGS:
De-icing (28891)
Instruments, Meteorological (52201)

ATI SHEET NO.:

Central Air Documents Office
Wright-Patterson Air Force Base, Dayton, Ohio

AIR TECH INDEX