

JAN 17 1947

ARR No. 4C01



3 1176 00115 9020

NATIONAL ADVISORY COMMITTEE FOR AERONAUTICS

WTRW-21

# WARTIME REPORT

ORIGINALLY ISSUED

March 1944 as  
Advance Restricted Report 4C01

AN INVESTIGATION OF AIRCRAFT HEATERS  
XIV - AN AIR AND HEAT FLOW ANALYSIS OF A  
RAM-OPERATED HEATER AND DUCT SYSTEM

By L. M. K. Boelter, E. H. Morrin, R. C. Martinelli,  
and H. F. Poppendiek  
University of California

# NACA

WASHINGTON

NACA WARTIME REPORTS are reprints of papers originally issued to provide rapid distribution of advance research results to an authorized group requiring them for the war effort. They were previously held under a security status but are now unclassified. Some of these reports were not technically edited. All have been reproduced without change in order to expedite general distribution.

NACA LIBRARY  
LANGLEY MEMORIAL AERONAUTICAL  
LABORATORY  
Langley Field, Va.

W-21

NATIONAL ADVISORY COMMITTEE FOR AERONAUTICS

ADVANCE RESTRICTED REPORT

AN INVESTIGATION OF AIRCRAFT HEATERS

XIV - AN AIR AND HEAT FLOW ANALYSIS OF A  
RAM-OPERATED HEATER AND DUCT SYSTEM

By L. N. K. Boelter, E. H. Morrin, R. C. Martinelli,  
and E. F. Poppendiek

SUMMARY

A method of graphical analysis is outlined which allows the prediction of the thermal and aerodynamic performance of a ram-operated heater and duct system, for cabin heating or wing de-icing, at any altitude and airplane speed. This performance may be predicted from the isothermal total pressure drop across the components of the duct system at several ventilating air rates, and the thermal output of the heater at various air and exhaust gas rates.

INTRODUCTION

The performance of a ram-operated aircraft heater is determined largely by the amount of ventilating air which can be forced through the heater-duct system by the ram pressure. The ventilating air rate, at a fixed airplane speed and altitude, depends upon the resistance to the flow of ventilating air, not only of the heater but of the complete duct system from air scoop to the point of final air discharge. For a given duct system, the pressure drop at a fixed air rate depends on the density of the air passing through the system, and thus, at any given altitude the pressure drop for a fixed ventilating air rate is determined by the temperature of the air leaving the heater. Conversely, for a given ram pressure, the resultant air rate through the duct system depends upon the temperature of the air leaving the heater. Because the temperature of the air leaving the heat exchanger at

a particular ventilating air rate depends upon the thermal output of the heater, the determination of the performance of a heater duct system involves the simultaneous solution of a pressure drop equation and a heat transfer equation.

A graphical solution of these equations, for the determination of the weight rate of air passing through the heater-duct system and the temperature of the air leaving the heater, at any altitude and airplane speed, is presented in this report. If the desired ventilating air weight rate at a certain altitude and plane speed is known, the allowable duct losses may be determined by the method presented.

It is well recognized that, in many cases, the limitation on the design of a heat exchanger duct system is the question of allowable space and so forth, and in such cases the analysis presented below may not be pertinent, although it may be used as a guide for design.

This investigation, conducted at the University of California, was sponsored by, and conducted with financial assistance from, the National Advisory Committee for Aeronautics.

#### SYMBOLS

$A$	cross-sectional area of flow, $ft^2$
$A_a$	cross-sectional area of flow at section a, $ft^2$
$A_b$	cross-sectional area of flow at section b, $ft^2$
$A_h$	constant cross-sectional area of flow in heat exchanger, $ft^2$
$A_g$	cross-sectional area of flow at section 2-2 at inlet to air scoop, $ft^2$
$A_3$	cross-sectional area of flow at section 3-3, entrance to heat exchanger, $ft^2$
$A_4$	cross-sectional area of flow at section 4-4, exit from heat exchanger, $ft^2$

$A_5$	cross-sectional area at section 5-5 at entrance to isothermal discharge section, $\text{ft}^2$
$A_6$	cross-sectional area of duct at section 6-6 at point of final air discharge, $\text{ft}^2$
$c_p$	heat capacity of air, $\text{Btu/lb } ^\circ\text{F}$
$D$	hydraulic diameter of duct, $\text{ft}$
$F$	frictional pressure loss, $\text{lb/ft}^2$
$k \text{ Btu}$	1000 Btu (kilo Btu)
$g$	gravitational force per unit mass, $32.2 \text{ lb}/(\text{lb sec}^2/\text{ft})$
$L$	distance along duct, $\text{ft}$
$n$	exponent obtained from $\Delta F_{ab}$ against $\dot{W}_{iso}$ curves (See references 3 and 5.)
$P$	absolute static pressure, $\text{lb/ft}^2$
$P_1$	absolute static pressure in free air stream at any altitude, $\text{lb/ft}^2$
$P_2$	absolute static pressure at inlet to air scoop, $\text{lb/ft}^2$
$P_3$	absolute static pressure at entrance to heat exchanger, $\text{lb/ft}^2$
$P_4$	absolute static pressure at exit of heat exchanger, $\text{lb/ft}^2$
$P_5$	absolute static pressure at entrance to isothermal discharge section, $\text{lb/ft}^2$
$P_6$	absolute static pressure at point of final air discharge, $\text{lb/ft}^2$
$P_{iso}$	mean absolute static pressure in duct system during the isothermal total pressure test (or that based on calculations using appropriate data), $\text{lb/ft}^2$
$p$	static pressure, $\text{lb/ft}^2$
$q_{alt}$	thermal output of heater under operating conditions, $\text{Btu/hr}$

$q_{lab}$	thermal output of heater as measured in laboratory, Btu/hr
$R$	gas constant in $PV = RT$ , ft lb/lb $^{\circ}F$
$T$	absolute temperature, $^{\circ}R$
$T_a$	absolute temperature at section a, $^{\circ}R$
$T_b$	absolute temperature at section b, $^{\circ}R$
$T_1$	absolute temperature of air in free air stream, $^{\circ}R$
$T_2$	absolute temperature of air, just inside air scoop, $^{\circ}R$
$t_3$	temperature of air at entrance to heat exchanger, $^{\circ}F$
$T_3$	absolute temperature of air at entrance to heat exchanger, $^{\circ}R$
$t_4$	temperature of air leaving heat exchanger, $^{\circ}F$
$T_4$	absolute temperature of air leaving heat exchanger, $^{\circ}R$
$T_5$	absolute temperature of air after passing through non-isothermal duct, at entrance to isothermal discharge section, $^{\circ}R$
$T_{iso}$	absolute temperature of air passing through duct system during isothermal total-pressure test, $^{\circ}R$
$u_m$	mean velocity of flow at any section of duct, ft/sec
$u_1$	velocity of air stream relative to airplane, ahead of air scoop (true airspeed of airplane + air velocity produced by propeller), ft/sec
$u_2$	velocity of air relative to airplane at section 2-2, entrance to air scoop, ft/sec
$u_e$	velocity of air relative to airplane at point of final air discharge, ft/sec
$V$	specific volume of air (1/density), cu ft/lb
$V_a$	specific volume of air at section a, cu ft/lb
$V_b$	specific volume of air at section b, cu ft/lb
$V_1$	specific volume of air in free air stream, cu ft/lb
$V_2$	specific volume of air just inside air scoop, cu ft/lb

- $V_3$  specific volume of air at entrance to heat exchanger, cu ft/lb  
 $V_4$  specific volume of air at discharge from heater, cu ft/lb  
 $V_5$  specific volume of air after passing through non-isothermal duct, cu ft/lb  
 $V_6$  specific volume of air at point of final air discharge, cu ft/lb  
 $V_{iso}$  specific volume of air during isothermal total-pressure test, cu ft/lb  
 $W_a$  ventilating air rate, lb/hr  
 $W_g$  exhaust gas rate, lb/hr  
 $W_{iso}$  ventilating air rate during isothermal total-pressure test, lb/hr  
 $x$  distance along duct, ft  
 $\Delta L$  distance along duct, across which  $\Delta F$  is measured, ft  
 $\Delta F_{ab}$  isothermal frictional pressure loss between section a and section b, lb/ft<sup>2</sup>  
 $\Delta F_{1-2}$  frictional pressure loss between free air stream and entrance of air scoop, for isothermal conditions specified by  $P_{iso}$ ,  $T_{iso}$ ,  $W_{iso}$ , lb/ft<sup>2</sup>  
 $\Delta F_{2-3}$  frictional pressure loss between entrance of air scoop and entrance to heat exchanger, for isothermal conditions specified by  $P_{iso}$ ,  $T_{iso}$ ,  $W_{iso}$ , lb/ft<sup>2</sup>  
 $\Delta F_{3-4}$  frictional pressure loss across heat exchanger for isothermal conditions specified by  $P_{iso}$ ,  $T_{iso}$ , and  $W_{iso}$ , lb/ft<sup>2</sup>  
 $\Delta F_{4-5}$  frictional pressure loss along the air duct from the heat exchanger to the entrance of isothermal discharge section for the isothermal conditions specified by  $P_{iso}$ ,  $T_{iso}$ , and  $W_{iso}$ , lb/ft<sup>2</sup>. The isothermal pressure loss  $\Delta F_{4-5}$  is made up of the sum of the pressure losses through all bends, sudden expansions, straight duct, and

so forth, which occur along the duct from the heater to the entrance to the isothermal discharge section.

- $\Delta F_{5-5}$  frictional pressure loss in isothermal discharge section for the isothermal condition specified by  $P_{iso}$ ,  $T_{iso}$ , and  $W_{iso}$ , lb/ft<sup>2</sup>
- $\zeta$  isothermal friction factor defined by  $\Delta F = \zeta \frac{\Delta L}{D} \frac{u_m^2}{2g}$
- $T_{a_1}$  temperature of air entering heat exchanger, °F
- $T_{g_1}$  temperature of hot exhaust gases entering heat exchanger, °F
- $K_e$  frictional pressure loss coefficient for fluid expansion or contraction defined by equation (5)
- $K_b$  frictional pressure loss coefficient for bends, and so forth, defined by equation (5)
- $k$  exponent for adiabatic compression defined by equation  $PV^k = P_1 V_1^k$

### BASIC EQUATIONS

The derivation of the equation for the prediction of the non-isothermal pressure drop through a heater-duct system, follows directly from the integration of the modified Bernoulli equation along the flow system.

The basic elements of a heater-duct system are shown in figure 1, total-head tubes being visualized as located at sections 1 to 6.

Two distinct types of flow system are indicated in figure 1:

Type I - Isothermal flow - unequal cross-sectional areas at points of total pressure measurement

Type II - Non-isothermal flow - unequal cross-sectional areas at points of total pressure measurement

The components of the flow system shown in figure 1 may be classified as follows:

1. The approach section, in which the air is adiabatically compressed by the motion of the airplane through the air. The flow is non-isothermal.

2. The inlet section, in which the cross-sectional areas at the two total head stations 1 and 2 are different and the flow is isothermal (type I)

3. The heater, which in the general case is assumed to have unequal cross-sectional areas at the two total head sections 2 and 3, and in which the flow is non-isothermal (type II)

4. The discharge duct, in which the cross-sectional areas at points 3 and 4 differ and the flow is non-isothermal because of heat losses along the duct (type II)

5. The final discharge section is of the same type as the inlet section (type I)

The Bernoulli equation in differential form (including friction, but neglecting elevation differences) is:

$$-V dp = \frac{u_m du_m}{g} + V dF \quad (1)$$

A second convenient method of writing equation (1) is:

$$-dp = \left( \frac{W}{3600} \right)^2 \frac{1}{gV} \left( \frac{Y}{A} \right) d \left( \frac{Y}{A} \right) + dF \quad (2)$$

Equation (2) results from the substitution of  $u_m = \frac{WV}{3600 A}$  into equation (1). The significance of the terms in equations (1) and (2) is as follows:

1. The first term represents the difference in static pressure due to both the changes in kinetic energy of the fluid and frictional losses.

2. The second term represents the change in pressure due to changes in the kinetic energy of the fluid, which may result from:

(a) Changes in density or specific volume ( $V$ )

(b) Changes in cross-sectional area of flow ( $A$ )

3. The last term represents the change in pressure due to frictional losses. The latter loss is irrecoverable, since the energy lost by friction is dissipated in the form of heat.

Equations (1) and (2) may be integrated between any points in the flow system subject to the restrictions imposed upon the use of the Bernoulli equation. The integration of the second term in equation (2), in particular, yields different results for the two types of flow system discussed.

Type I. Isothermal flow - unequal cross-sectional areas at points of total pressure measurement.-

$$\int_a^b \left( \frac{W}{3600} \right)^2 \frac{1}{gV} \left( \frac{V}{A} \right) d \left( \frac{V}{A} \right) = \left( \frac{W}{3600} \right)^2 \frac{V}{2g} \left[ \left( \frac{1}{A_b} \right)^2 - \left( \frac{1}{A_a} \right)^2 \right] \quad (3)$$

Type II. Non-isothermal flow - unequal cross-sectional areas at points of total pressure measurement.- For this case the integral cannot be evaluated precisely, since the integrand is not an exact differential as it was for case I. Several methods of approximation may be used.

(a) Average specific volume.- If the flow system is nearly isothermal, the following approximation may be used:

$$\frac{1}{V_{av}} \int_a^b \left( \frac{W}{3600} \right)^2 \frac{1}{g} \left( \frac{V}{A} \right) d \left( \frac{V}{A} \right) = \left( \frac{W}{3600} \right)^2 \frac{1}{2g V_{av}} \left[ \left( \frac{V_b}{A_b} \right)^2 - \left( \frac{V_a}{A_a} \right)^2 \right] \quad (4a)$$

(b) Average cross-sectional area.- If the area is almost constant, the following approximation may be used:

$$\frac{1}{A_{av}} \int_a^b \left( \frac{W}{3600} \right)^2 \frac{1}{g} d \left( \frac{V}{A} \right) = \left( \frac{W}{3600} \right)^2 \frac{1}{g A_{av}} \left[ \left( \frac{V_b}{A_b} \right) - \left( \frac{V_a}{A_a} \right) \right] \quad (4b)$$

(c) If the area is constant, no approximation is necessary, for the integral can be evaluated exactly.

$$\frac{1}{A^2} \int_a^b \left( \frac{W}{3600} \right)^2 \frac{1}{g} dV = \left( \frac{W}{3600} \right)^2 \frac{1}{g A^2} [v_b - v_a] \quad (4c)$$

(d) For the system shown below, which represents a heat exchanger of constant cross-sectional area  $A_h$ ,

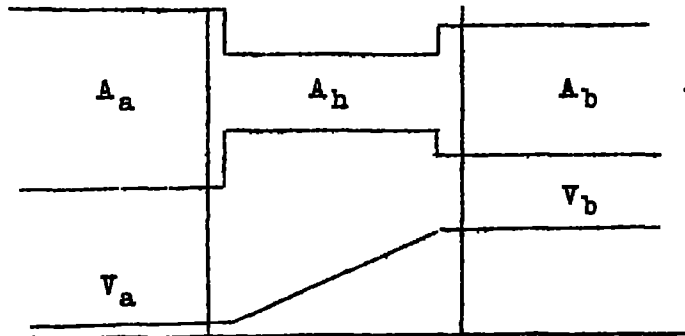

application of equations (3) and (4c) yields:

$$\int_a^b \left( \frac{W}{3600} \right)^2 \frac{1}{g} \frac{v}{A} d \left( \frac{v}{A} \right) = \left( \frac{W}{3600} \right)^2 \frac{v_a}{2g A_h^2} \left[ \left( \frac{A_h^2}{A_b^2} + 1 \right) \frac{T_b}{T_a} - \left( \frac{A_h^2}{A_a^2} + 1 \right) \right] \quad (4d)$$

An isothermal contraction (or expansion) at point a, a non-isothermal change of the fluid at constant cross-sectional area, and then an isothermal expansion (or contraction) at point b is considered for the derivation of the preceding expression.

The third term in equations (1) and (2) may be evaluated as follows: The irrecoverable frictional loss for flow in a conduit usually consists of:

1. Skin friction losses in straight sections of the duct
2. Losses due to sudden expansions and contractions

## 3. Losses due to flow around bends, and so forth

The skin friction loss usually is expressed by

$$dF_1 = \zeta \frac{u_m^2}{2g} \frac{dx}{DV} = \zeta \left( \frac{W}{3600} \right)^2 \frac{V}{2g DA^2} dx$$

where  $\zeta$ , the friction factor, is a function of the Reynolds number of the flow system.

The losses by sudden expansion and contraction usually are expressed by an equation of the form

$$dF_2 = K_e \frac{u_m^2}{2g V} = K_e \left( \frac{W}{3600} \right)^2 \frac{V}{2g A^2}$$

where the expansion coefficient  $K_e$  may be estimated from data in references 1 and 2.

The losses due to flow around bends also are expressed by an equation of the form

$$dF_3 = K_b \frac{u_m^2}{V 2g} = K_b \left( \frac{W}{3600} \right)^2 \frac{V}{2g A^2}$$

Thus, for a duct which includes several bends, sudden expansions, and so forth (see references 1 and 2),

$$dF = \left( \frac{W}{3600} \right)^2 \frac{1}{2g} \left[ \zeta \frac{V}{DA^2} dx + \dots + K_e \frac{V}{A^2} + \dots + K_b \frac{V}{A^2} + \dots \right]$$

Integrating along the whole duct length for conditions of  $W_{iso}$ ,  $P_{iso}$ ,  $T_{iso}$  yields

$$\Delta F_{ab} = \left( \frac{W_{iso}}{3600} \right)^2 \frac{V_{iso}}{2g} \left[ \sum \zeta \frac{L}{DA^2} + \sum \frac{K_e}{A^2} + \sum \frac{K_b}{A^2} \right] \quad (5)$$

A plot of  $\Delta F_{ab}$  against  $W_{iso}$  usually will reveal an equation of the form

$$\Delta F_{ab} = K \frac{V_{iso}}{2g} \left( \frac{W_{iso}}{3600} \right)^n$$

where  $K$  varies slightly with temperature because of the variation of Reynolds number with temperature and the resultant change of the friction factor  $f$ . The exponent  $n$  will vary somewhere between 1.75 and 2.00 due to the variation of the friction factor  $f$  with  $W$ . If the greatest friction loss is due to expansions and contractions,  $n$  will be near 2. If the greatest loss is due to skin friction, the exponent will be near 1.75. Typical values of  $n$  are given in references 3 and 4.

In reference 3 it has been shown that the isothermal pressure loss  $\Delta F_{ab}$  can be corrected to non-isothermal conditions by correcting for changes in specific volume and viscosity with temperature. If the exponent  $n$  is known, the non-isothermal frictional pressure loss at any weight rate  $W$  is therefore:

$$\Delta F_{ab}(\text{non-isothermal}) = \Delta F_{ab} \left( \frac{W}{W_{\text{iso}}} \right)^n \left( \frac{T_a + T_b}{2T_{\text{iso}}} \right)^{0.13} \left( \frac{V_a + V_b}{2V_{\text{iso}}} \right) \quad (6)$$

where

$\Delta F_{ab}$  isothermal frictional pressure loss between section a and section b at the temperature  $T_{\text{iso}}$ , air specific volume  $V_{\text{iso}}$ , and weight rate  $W_{\text{iso}}$ , lb/ft<sup>2</sup>

$W$  weight rate of air, lb/hr

$n$  exponent (between 1.75 and 2.0) obtained from plot of  $\Delta F_{ab}$  against  $W_{\text{iso}}$

$\frac{T_a + T_b}{2}$  arithmetic average temperature in length of duct ab, °R

$\frac{V_a + V_b}{2}$  arithmetic average specific volume of air in length of duct ab, cu ft/lb

INTEGRATION OF BERNOULLI EQUATION ALONG HEATER-DUCT SYSTEM

Free Stream to Entrance of Scoop

(Sections 1 and 2)

Flow system - (unequal flow areas, compressible flow).

In order to show the effect of the compressibility of the fluid between sections 1 and 2 the frictional loss  $\Delta F_{1-2}$  is postulated to be negligible. Compressibility effects, on the other hand, cannot be neglected. Equation (1) then becomes:

$$-V dp = \frac{u_m du_m}{g}$$

The thermodynamic path followed by the air passing from section (1) to section (2) is postulated to be adiabatic. Then:

$$pV^k = P_1 V_1^k$$

Thus

$$-\int_{P_1}^{P_2} V dp = -P_1^{\frac{1}{k}} V_1 \int_{P_1}^{P_2} \frac{dp}{P^{\frac{k}{k-1}}} = \frac{k}{k-1} P_1 V_1 \left[ 1 - \left( \frac{P_2}{P_1} \right)^{\frac{k-1}{k}} \right]$$

and from equation (1)

$$\frac{k}{k-1} P_1 V_1 \left[ 1 - \left( \frac{P_2}{P_1} \right)^{\frac{k-1}{k}} \right] = \frac{u_2^2 - u_1^2}{2g} \quad (7)$$

An approximate solution of the preceding equation for  $(P_2 - P_1)$ , which is accurate to within 10 percent if

$\frac{P_2 - P_1}{P_1} < 0.4$  is presented below:

Because

$$\frac{P_2}{P_1} = \frac{P_1 + (P_2 - P_1)}{P_1} = 1 + \frac{P_2 - P_1}{P_1}$$

then

$$\left(\frac{P_2}{P_1}\right)^{\frac{k-1}{k}} = \left(1 + \frac{P_2 - P_1}{P_1}\right)^{\frac{k-1}{k}} \approx 1 + \frac{k-1}{k} \left(\frac{P_2 - P_1}{P_1}\right) + \dots$$

Neglecting all but the first two terms, and substituting in equation (7) yields

$$-(P_2 - P_1) = \frac{u_2^2 - u_1^2}{2g V_1} \quad (8a)$$

which is the solution that would result by considering the fluid incompressible.

The frictional pressure loss  $\Delta F_{1-2}$  (which was neglected in determining the effect of fluid compressibility) is added to equation (8a) for use in the following flow equations, yielding

$$P_1 - P_2 = \frac{u_2^2}{2gV_1} - \frac{u_1^2}{2gV_1} + \Delta F_{f-2} \left(\frac{W}{W_{iso}}\right)^n \left(\frac{T_1 + T_2}{2T_{iso}}\right)^{0.13} \left(\frac{V_1 + V_2}{2V_{iso}}\right) \quad (8b)$$

Although the pressure  $P_2$  is not greatly influenced by compressibility effects, the temperature at point (2) may be several degrees higher than that of the free air stream due to compressibility. The temperature  $T_2$  may be readily estimated.

Substitution of the relations

$$P_1 V_1 = RT_1$$

$$P_2 V_2 = RT_2$$

and

$$P_1 V_1^k = P_2 V_2^k$$

in equation (7) yields

$$\frac{u_2^2 - u_1^2}{2g} = \frac{Rk}{k-1} \left[ T_1 - T_2 \right]$$

or

$$T_2 = T_1 + \frac{k-1}{Rk} \left[ \frac{u_1^2 - u_2^2}{2g} \right] \quad (9)$$

Scoop to Heater

(Sections 2 and 3)

Flow system - type I (isothermal, unequal flow areas).-

Integrating equation (1) between sections 2 and 3 gives

$$P_2 - P_3 = \frac{u_3^2}{2gV_3} - \frac{u_2^2}{2gV_2} + \Delta F_{2-3} \left( \frac{W}{W_{iso}} \right)^n \left( \frac{T_2+T_3}{2T_{iso}} \right)^{0.13} \left( \frac{V_2+V_3}{2V_{iso}} \right) \quad (10)$$

or, since  $u = \frac{WV}{3600A}$  and  $T_2 = T_3$ ,  $V_2 = V_3$

$$P_2 - P_3 = \left( \frac{W}{3600} \right)^2 \frac{V_3}{2gA_3} - \frac{u_2^2}{2gV_2} + \Delta F_{2-3} \left( \frac{W}{W_{iso}} \right)^n \left( \frac{T_2}{T_{iso}} \right)^{0.13} \left( \frac{V_2}{V_{iso}} \right) \quad (11)$$

Adding equations (11) and (8b) in order to eliminate  $u_2$  results in the equation\*

$$\left( P_1 + \frac{u_1^2}{2gV_1} \right) - P_3 = \left( \frac{W}{3600} \right)^2 \frac{V_3}{2gA_3} + \Delta F_{1-2} \left( \frac{W}{W_{iso}} \right)^n \left( \frac{T_1+T_2}{2T_{iso}} \right)^{0.13} \left( \frac{V_1+V_2}{2V_{iso}} \right) \\ + \Delta F_{2-3} \left( \frac{W}{W_{iso}} \right)^n \left( \frac{T_2}{T_{iso}} \right)^{0.13} \left( \frac{V_2}{V_{iso}} \right) \quad (12)$$

Note that  $P_1 + \frac{u_1^2}{2gV_1}$  is equal to total pressure in free air stream before scoop.

Heater

(Sections 3 and 4)

Flow system - type II (non-isothermal, unequal flow areas).- The integration of equation (2) between points 3 and 4 yields:

---

\*A term involving the difference in the specific volumes at sections 1 and 2 is neglected in the determination of equation (12).

$$P_3 - P_4 = \left(\frac{W}{3600}\right)^2 \frac{V_3}{2g A_h^3} \left[ \left(\frac{A_h^2}{A_4^2} + 1\right) \frac{T_4}{T_3} - \left(\frac{A_h^2}{A_3^2} + 1\right) \right] \\ + \Delta F_{3-4} \left(\frac{W}{W_{iso}}\right)^n \left(\frac{T_3+T_4}{2T_{iso}}\right)^{0.13} \left(\frac{V_3+V_4}{2V_{iso}}\right) \quad (13)$$

Discharge Duct

(Sections 4 and 5)

Flow system - type II (non-isothermal unequal flow areas). - Integration of equation (2) yields

$$(P_4 - P_5) = \left(\frac{W}{3600}\right)^2 \frac{1}{g(V_4 + V_5)} \left[ \left(\frac{V_5}{A_5}\right)^2 - \left(\frac{V_4}{A_4}\right)^2 \right] \\ + \Delta F_{4-5} \left(\frac{W}{W_{iso}}\right)^n \left(\frac{T_4+T_5}{2T_{iso}}\right)^{0.13} \left(\frac{V_4+V_5}{2V_{iso}}\right) \quad (14)$$

Final Discharge Section

(Sections 5 and 6)

Flow system - type I (isothermal, unequal areas). - Integration of equation (1) yields

$$P_5 - P_6 = \frac{u_6^2}{2gV_6} - \frac{u_5^2}{2gV_5} + \Delta F_{5-6} \left(\frac{W}{W_{iso}}\right)^n \left(\frac{T_5}{T_{iso}}\right)^{0.13} \left(\frac{V_5}{V_{iso}}\right) \quad (15)$$

or

$$P_5 - \left(P_6 + \frac{u_6^2}{2gV_6}\right) = - \left(\frac{W}{3600}\right)^2 \frac{V_5}{2gA_5^2} \\ + \Delta F_{5-6} \left(\frac{W}{W_{iso}}\right)^n \left(\frac{T_5}{T_{iso}}\right)^{0.13} \left(\frac{V_5}{V_{iso}}\right) \quad (16)$$

where  $P_6 + \frac{u_6^2}{2gV_6}$  is equal to total pressure at point of air discharge,

Eliminating the intermediate pressures  $P_3$ ,  $P_4$ , and  $P_5$  between equations (12), (13), (14), and (15) results in the equation for the pressure drop between points 1 and 6

$$\begin{aligned} & \left( P_1 + \frac{u_1^2}{2gV_1} \right) - \left( P_6 + \frac{u_6^2}{2gV_6} \right) = \left( \frac{W}{3600} \right)^2 \frac{1}{2g} \\ & \left\{ \frac{V_3}{A_3^2} + \frac{V_3}{A_h^2} \left[ \left( \frac{A_h^2}{A_4^2} + 1 \right) \frac{T_4}{T_3} - \left( \frac{A_h^2}{A_3^2} + 1 \right) \right] + \frac{2}{V_5 + V_4} \right. \\ & \left. \left[ \left( \frac{V_5}{A_5} \right)^2 - \left( \frac{V_4}{A_4} \right)^2 \right] - \frac{V_6}{A_5} \right\} + \left( \frac{W}{W_{iso}} \right)^n \left\{ \Delta F_{1-2} \left( \frac{T_1 + T_2}{2T_{iso}} \right)^{0.13} \left( \frac{V_1 + V_2}{2V_{iso}} \right) \right. \\ & + \Delta F_{2-3} \left( \frac{T_2}{T_{iso}} \right)^{0.13} \left( \frac{V_2}{V_{iso}} \right) + \Delta F_{3-4} \left( \frac{T_3 + T_4}{2T_{iso}} \right)^{0.13} \left( \frac{V_3 + V_4}{2V_{iso}} \right) \\ & \left. + \Delta F_{4-5} \left( \frac{T_4 + T_5}{2T_{iso}} \right)^{0.13} \left( \frac{V_4 + V_5}{2V_{iso}} \right) + \Delta F_{5-6} \left( \frac{T_5}{T_{iso}} \right)^{0.13} \left( \frac{V_5}{V_{iso}} \right) \right\} \quad (17) \end{aligned}$$

By the use of the ideal gas equation  $PV = RT$  equation (17) may be simplified

$$\begin{aligned} & \left( P_1 + \frac{u_1^2}{2gV_1} \right) - \left( P_6 + \frac{u_6^2}{2gV_6} \right) = \left( \frac{W}{3600} \right)^2 \frac{R}{2gP_1} \\ & \left\{ \frac{T_3}{A_3^2} + \frac{T_3}{A_h^2} \left[ \left( \frac{A_h^2}{A_4^2} + 1 \right) \frac{T_4}{T_3} - \left( \frac{A_h^2}{A_3^2} + 1 \right) \right] + \frac{2}{T_4 + T_5} \right. \\ & \left. \left[ \left( \frac{T_5}{A_5} \right)^2 - \left( \frac{T_4}{A_4} \right)^2 \right] - \frac{T_6}{A_5} \right\} + \left( \frac{W}{W_{iso}} \right)^n \left( \frac{P_{iso}}{P_1} \right) \left\{ \Delta F_{1-2} \left( \frac{T_1 + T_2}{2T_{iso}} \right)^{1.13} \right. \\ & + \Delta F_{2-3} \left( \frac{T_2}{T_{iso}} \right)^{1.13} + \Delta F_{3-4} \left( \frac{T_3 + T_4}{2T_{iso}} \right)^{1.13} \\ & \left. + \Delta F_{4-5} \left( \frac{T_4 + T_5}{2T_{iso}} \right)^{1.13} + \Delta F_{5-6} \left( \frac{T_5}{T_{iso}} \right)^{1.13} \right\} \quad (18) \end{aligned}$$

In equation (18) the terms on the left of the equal sign represent the difference in total pressure between the free air stream and the point of air discharge. The first term on the right of the equal sign represents the pressure changes due to the acceleration of the air in the duct, which are due both to changes in area and changes in specific volume. The last term represents the irrecoverable pressure loss due to the friction in the complete duct systems. It should be noted that each isothermal frictional pressure loss is corrected to the operating temperature by different temperature corrections, depending on the type of flow system represented by each separate  $\Delta F$ . Thus, any complex flow system can be broken up into a series of systems, and the pressure drop through each corrected to non-isothermal condition by the method outlined.

In equation (18), for a given duct system for which the isothermal total pressure drops  $\Delta F_{1-2}$ ,  $\Delta F_{2-3}$ ,  $\Delta F_{3-4}$ ,  $\Delta F_{4-5}$ , and  $\Delta F_{5-6}$  are known, the remaining unknowns are  $W$  and  $T_4$ . The fixing of the altitude, the airplane speed, and the heat loss from the duct establishes all other variables in the equation. Thus, for any altitude and airplane speed a curve of  $W$  against  $T_4$  can be drawn which will reveal the rate of flow possible through the duct system for any temperature  $T_4$ .

The relative importance of the various portions of the duct system may be readily established, for the largest of the corrected pressure drop terms in equation (18) will be the term which controls the rate of air flow. If it becomes necessary to increase the rate of flow through the heater-duct system, attention should be focused on the largest term. By breaking up a complex duct system into a series of small units, the units causing difficulty then may be readily isolated.

**Note:** In many cases, the first sum of terms on the right-hand side of equation (18) (which involves pressure drops due to changes in area and fluid temperature) may be neglected when compared with the second sum of terms involving the frictional pressure losses ( $\Delta F$ ).

After the curve of  $W$  against  $T_4$  is established from a consideration of the pressure drop characteristics of the duct system (from equation (18)), the thermal performance of the heater must be utilized in order to

establish the operating point of the heater-duct system. This thermal performance of the heater then is used to establish a second curve of  $W$  against  $T_4$ , which is fixed by the thermal output of the heater, since for any particular  $W$  and exhaust-gas temperature only one magnitude of  $T_4$  is possible. The relation

$$q_{alt} = Wc_p (T_4 - T_3) \quad (19)$$

or

$$T_4 = \frac{q_{alt}}{Wc_p} + T_3 \quad (20)$$

is utilized to obtain this second curve. The heater capacity  $q_{lab}$ , determined in the laboratory, must be corrected to altitude and temperature conditions by the method outlined in reference 5. The intersection of the curve of  $W$  against  $T_4$  obtained from the pressure drop characteristics of the heater-duct system (equation (18)) and the curve of  $W$  against  $T_4$  from equation (20) fixes the operating point of the system at the particular altitude and airplane speed under consideration. A series of calculations at various altitudes and airplane speeds then will establish the complete performance of the unit.

### Recapitulation

The performance of a ram-operated heater-duct system depends on the pressure loss characteristics of the complete system and the thermal output of the heater.

The following data must be known in order to establish the performance of the system:

1. Thermal output of the heater as a function of air rate at various exhaust gas rates and exhaust gas temperatures. The methods of correction of the performance of the heater to any altitude are presented in reference 5.

2. Isothermal total pressure loss through the various pertinent portions of the air duct system. Total pressure data are necessary in order to evaluate the irrecoverable frictional pressure loss.
3. Airplane speed, altitude, air temperature, and static pressure in the free air stream
4. Heat loss from discharge duct\*
5. Static pressure at the point of final air discharge

If these quantities are known, the complete performance of the heater-duct system may be calculated at any altitude. Or, if the weight rate  $W$  is fixed by design at a certain altitude and airplane speed, the allowable isothermal total pressure loss for any section of the duct system may be calculated.

#### EXAMPLE

An example of the application of equation (18) to the prediction of the performance of a ram-operated exhaust gas to air cabin heater and associated duct work as a function of airplane speed and altitude is presented below:

#### Data

The following data are available:

1. Thermal output of heater (fig. 2).-- The data shown in figure 2 were obtained in the laboratory for the following conditions:

- (a) Atmospheric pressure, 14.7 psia
- (b) Temperature of air entering heater,  $T_{a_1}$ , 100° F
- (c) Temperatures of exhaust gas entering heater,  $T_{g_1}$ , 1400° F

---

\*The duct loss can be estimated by means of the equations presented in reference 3.

For purposes of the analysis the following flight conditions will be utilized:\*

Altitude ---(ft)---	$T_{g_1}$ (deg F)	$T_{a_1}$ (deg F)	$W_g$ (lb/hr)
10,000	1600	+23	4000
20,000	1600	-12	4000
30,000	1600	-48	4000
40,000	1600	-67	4000

With this data and the data in figure 2 the heater output, and thus the temperature of the air leaving the heater,  $t_4$ , may be calculated readily for any air rate,  $W_a$ , through the heater. This procedure will yield one of the curves of  $W_a$  against  $t_4$  required in the analysis.

2. The isothermal total pressure drop data for the heater-duct system for an air rate of 3000 pounds per hour are shown in figure 3. The exponent  $n = 1.8$ .

3. The performance of the unit is desired at the following airplane speeds and altitudes:

Altitude (ft)	$T_1$ (deg R)	$P_1$ (lb/ft <sup>2</sup> )	$V_1$ (cu ft/lb)	Airplane speed (true air speed) (mph)
10,000	483	1460	17.7	100
20,000	448	972	24.5	200
30,000	412	627	35.0	300
40,000	393	392	53.5	400

4. Heat loss from discharge duct is 1000\*\* Btu/hr ft<sup>2</sup>.  
Surface area of duct is 24 ft<sup>2</sup>.

\*For lack of better information, and in order to reduce the complexity of the sample calculation, constant magnitudes of  $T_{g_1}$  and  $W_g$  were used for all airplane speeds and altitudes. If data for the variation of  $T_{g_1}$  and  $W_g$  with altitude and airplane speed are available, they may be readily utilized in the analysis in place of the constant values employed in this report.

\*\*The duct loss can be estimated by means of the equations presented in reference 3.

5. Static pressure in cabin is equal to atmospheric pressure at the given altitude.

### Sample Calculation

A sample calculation is performed for an altitude of 30,000 feet.

1. Calculations of weight rate  $W$  as a function of  $t_4$  from pressure drop data at an airplane speed of 300 miles per hour. Equation (18) is utilized. The various terms in equation (18) have been assigned the following magnitudes for this calculation:

	<u>Source</u>
$P_1 = P_e = 627 \text{ lb/sq ft (4.35 lb/sq in.)}$	Design condition
$u_1 = 300 \text{ mph} = 441 \text{ ft/sec}$	" "
$V_1 = 35 \text{ cu ft/lb}$	" "
$g = 32.2 \text{ ft/sec}^2$	" "
$R = 53.3 \text{ ft } ^\circ\text{R}^{-1}$	" "
$n = 1.8$	" "
$T_1 = 412^\circ \text{ R}$	" "
$T_B = T_3 = 427^\circ \text{ R}$	Equation (9)
$A_h = 0.235 \text{ ft}^2$	Figure 3
$A_3 = 0.225 \text{ ft}^2$	" "
$A_4 = 0.245 \text{ ft}^2$	" "
$A_5 = 0.196 \text{ ft}^2$	" "
$A_e = 0.500 \text{ ft}^2$	" "
$T_e = T_5 = T_4 - \frac{24 \times 1000}{0.24 \times W}$	Design condition
$c_p = 0.24 \text{ Btu/lb } ^\circ\text{F}$	Reference 5

	Source
$W_{iso} = 3000 \text{ lb/hr}$	Figure 3
$T_{iso} = 532^\circ \text{ R}$	" "
$P_{iso} = 2120 \text{ lb/ft}^2 = 147 \text{ lb/sq in.}$	" "
$\Delta F_{1-2} = 0.52 \text{ lb/ft}^2 \text{ (0.1 in. H}_2\text{O)}$	" "
$\Delta F_{2-3} = 0.52 \text{ lb/ft}^2 \text{ (0.1 in. H}_2\text{O)}$	" "
$\Delta F_{3-4} = 6.23 \text{ lb/ft}^2 \text{ (1.2 in. H}_2\text{O)}$	" "
$\Delta F_{4-5} = 11.7 \text{ lb/ft}^2 \text{ (2.25 in. H}_2\text{O)}$	" "
$\Delta F_{5-6} = 2.69 \text{ lb/ft}^2 \text{ (0.50 in. H}_2\text{O)}$	" "

Substitution of these quantities in equation (18) yields an equation in  $W$  (the ventilating air rate) and  $T_4$  (the temperature of the air leaving the heater). Choosing arbitrary values of  $t_4 = 200^\circ, 400^\circ, 600^\circ, 800^\circ,$  and  $1000^\circ \text{ F}$  results in the following equation in  $W$ . The coefficients  $A$  and  $B$  are the multipliers of  $W^2$  and  $W^{1.8}$  (since  $n = 1.8$ ), respectively, in equation (18).

$$86.5 = A W^2 + B W^{1.8}$$

where

	$t_4$ (deg F)	$A \times 10^8$	$B \times 10^8$	$W$ (lb/hr)
Altitude	200	61	4510	3070
30,000 ft	400	105	5920	2620
and	600	149	7360	2320
Airplane speed,	800	205	8790	2110
300 mph	1000	237	10300	1930

A plot of the curve  $W$  against  $t_4$  obtained in the foregoing is shown in figure 4, together with the curves calculated for airplane speeds of 100, 200, and 400 miles per hour.

The heater output must now be utilized to obtain the operating points of the heater-duct system. From figure 2 the following data are obtained:

	$W_a$	$q_{lab}$	$q_{alt}$	$\frac{q_{alt}}{W_{cp}}$	$t_4$
	(lb/hr)	(Btu/hr)	(Btu/hr)		(deg F)
Altitude,	1000	150,000	188,000	783	751
30,000 ft.	2000	215,000	270,000	562	529
and	3000	270,000	340,000	472	439
Airplane speed,	4000	310,000	390,000	406	372
300 mph	5000	337,000	424,000	353	317

The laboratory data were corrected to altitude by multiplying by the ratio:\*

$$q_{alt} = q_{lab} \left( \frac{1600 - t_3}{1400 - 100} \right)$$

The temperature  $t_4$  was calculated from the relation:

$$q_{alt} = W_{cp} (t_4 - t_3) \quad (21)$$

The resulting curve of  $W$  against  $t_4$  is plotted in figure 4. The intersection of the curve obtained from the heat transfer data\*\* and the curves obtained from the pressure drop data yields the operating points for the heater-duct system at 30,000 feet altitude. This performance is summarized as follows:

\*This correction neglects the small changes in heater output due to changes in the unit conductances on the air and gas sides resulting from the fact that the average operating temperatures of the air and exhaust gases are different from those utilized in the laboratory test (reference 5). The temperature  $t_3$  is equal to the outside air temperature ( $-48^\circ \text{F}$ ) plus the temperature rise due to adiabatic compressibility.

\*\*If variations of heater output with airplane speed due to changes in exhaust gas rate and temperature are to be included in the computations, a separate curve of  $W$  against  $t_3$  from the heater output data will be obtained at each airplane speed. Since the exhaust gas rate is assumed to be constant in these calculations, the heater performance is represented by a single curve in fig. 4.

## Altitude, 30,000 ft

Airplane speed (mph)	W (lb/hr)	$t_4$ (deg F)	$q_{alt}$ (Btu/hr)
100	550	960	133,000
200	1420	625	230,000
300	2450	475	310,000
400	3600	390	380,000

The repetition of the preceding procedure for altitudes of 10,000, 20,000, and 40,000 feet yields the complete performance of the unit. The final results are tabulated in table I and plotted in figures 5, 6, and 7.

## DISCUSSION OF RESULTS

Figure 5 reveals the temperature at which the air will leave the heater at various airplane speeds and altitudes. Inspection of the figure shows that the lower the airplane speed the higher the temperature of the air leaving the heater, and the greater the altitude, the higher the temperature leaving the heater. All the calculations for figure 5 were based on a ventilating air duct in which no air-control valves were installed, and thus figure 5 represents the optimum performance of the unit. Installation of valves for restricting the rate of air flow will, of course, have the same effect as increasing the resistance to flow of the duct.\*

Figure 5 represents the air rate through the heater-duct system at various altitudes and air speeds. As would be expected, the lower the altitude and the higher the airplane speed, the greater the air rate. Combination of the data presented in figures 5 and 6 allows the prediction of heater output at various altitudes and airplane speeds. These results are shown in figure 7.

The data in figures 5, 6, and 7 establishes the performance of the heater-duct system. The same calculations may be readily performed for a wing de-icing system, the

---

\*If a blower is installed in the ventilating air duct on the upstream side of the heater to supplement the ram pressure, a term  $\Delta P_{fan}$ , equal to the pressure head provided by the blower, may be added to the left side of equation (18). The remainder of the analysis remains unchanged.

main difference in the calculation being a greatly lowered  $T_g$  due to the heat lost by the air as it flows in the wing de-icing ducts (between sections 4 and 5).

Cases may arise in which the duct system is fixed and the performance of several heaters in this given duct system is to be compared. Repetition of the calculation shown for the various heaters will allow a rational comparison of the performance of the several heaters to be made.

In other cases the heater output at a given altitude and airplane speed may be fixed by design, and the allowable duct losses must be determined. The following procedure may be followed in this case:

- (a) From the known heater output as a function of air rate, gas rates, and temperatures, the desired air rate  $W$  and air outlet temperature  $t_4$  may be calculated by employing equation (20).
- (b) Substitution of these values of  $W$  and  $t_4$  into equation (15) allows the evaluation of one unknown isothermal pressure drop, say  $\Delta F_{4-5}$ . The duct then must be designed to function within this allowable pressure drop.

### CONCLUSIONS

A method has been presented in this report for the prediction of the approximate thermal and aerodynamic performance of a ram-operated heater and duct system at any altitude and airplane speed, provided the following data are known:

- (a) Thermal output of heater at various air rates and exhaust-gas rates
- (b) Isothermal total pressure drop (frictional loss) through duct system at several air rates
- (c) Heat loss from discharge duct (or wing, in de-icing system)

(d) Static pressure at the point of final air discharge

University of California,  
Berkeley, Calif., December 1943.

#### REFERENCES

1. O'Brien, H. P., and Nickox, G. H.: Applied Fluid Mechanics. McGraw-Hill Book Co., Inc., New York, N. Y., 1937, p 350.
  2. Committee A-9 Aircraft Air Conditioning Equipment: Airplane Heating and Ventilating Equipment. Engineering Data. SAE Jour., Jan. 1943.
  3. Martinelli, R. C., Weinberg, E. B., Morrin, E. H., and Boelter, L. H. K.: An Investigation of Aircraft Heaters. III - Measured and Predicted Performance of Double Tube Heat Exchangers. NACA ARR, Oct. 1942.
  4. Martinelli, R. C., Weinberg, E. B., Morrin, E. H., and Boelter, L. H. K.: An Investigation of Aircraft Heaters. IV - Measured and Predicted Performance of Longitudinally Finned Tubes. NACA ARR, Oct. 1942.
- Boelter, L. H. K., Miller, H. A., Sharp, W. H., Morrin, E. H., Iversen, H. W., and Mason W. E.: An Investigation of Aircraft Heaters. IX - Measured and Predicted Performance of Two Exhaust Gas-Air Heat Exchangers and an Apparatus for Evaluating Exhaust Gas-Air Heat Exchangers. NACA ARR, March 1943.
- Boelter, L. H. K., Dennison, H. G., Guibert, A. G., and Morrin, E. H.: An Investigation of Aircraft Heaters. X - Measured and Predicted Performance of a Fluted-Type Exhaust Gas and Air Heat Exchanger. NACA ARR, March 1943.
- Boelter, L. H. K., Miller, H. A., Sharp, W. H., and Morrin, E. H.: An Investigation of Aircraft Heaters. XI - Measured and Predicted Performance of a Slotted-Fin Exhaust Gas and Air Heat Exchanger. NACA ARR No. 3D16, April 1943.

- Boelter, L. M. K., Dennison, H. G., Guibert, A. G.,  
and Morrin, E. H.: An Investigation of Aircraft  
Heaters. XII - Performance of a Formed-Plate  
Crossflow Exhaust Gas and Air Heat Exchanger.  
NACA ARR No. 3E10, May 1943.
- Boelter, L. M. K., Guibert, A. G., Miller, M. A.,  
and Morrin, E. H.: An Investigation of Aircraft  
Heaters. XIII - Performance of Corrugated and  
Noncorrugated Fluted Type Exhaust Gas-Air Heat  
Exchangers. NACA ARR No. 3H26, Aug. 1943.
5. Boelter, L. M. K., Martinelli, R. C., Romie, F. E.,  
and Morrin, E. H.: An Investigation of Aircraft  
Heaters. XVIII - A Design Manual for Exhaust Gas  
and Air Heat Exchangers. NACA ARR No. 5A06, 1945.

TABLE I

Altitude (ft)	True airspeed of airplane (mph)	$t_4$ (deg F)	$\dot{W}$ (lb/hr)	$q_{alt}$ (Btu/hr)
10,000	100	635	1550	228,000
	200	430	3750	366,000
	300	300	6400	426,000
	400			
20,000	100	785	930	179,000
	200	500	2400	296,000
	300	390	4000	386,000
	400	300	5850	439,000
30,000	100	960	550	133,000
	200	625	1420	230,000
	300	475	2450	308,000
	400	390	3600	380,000
40,000	100	1200	320	97,000
	200	800	800	167,000
	300	635	1360	230,000
	400	510	2000	277,000

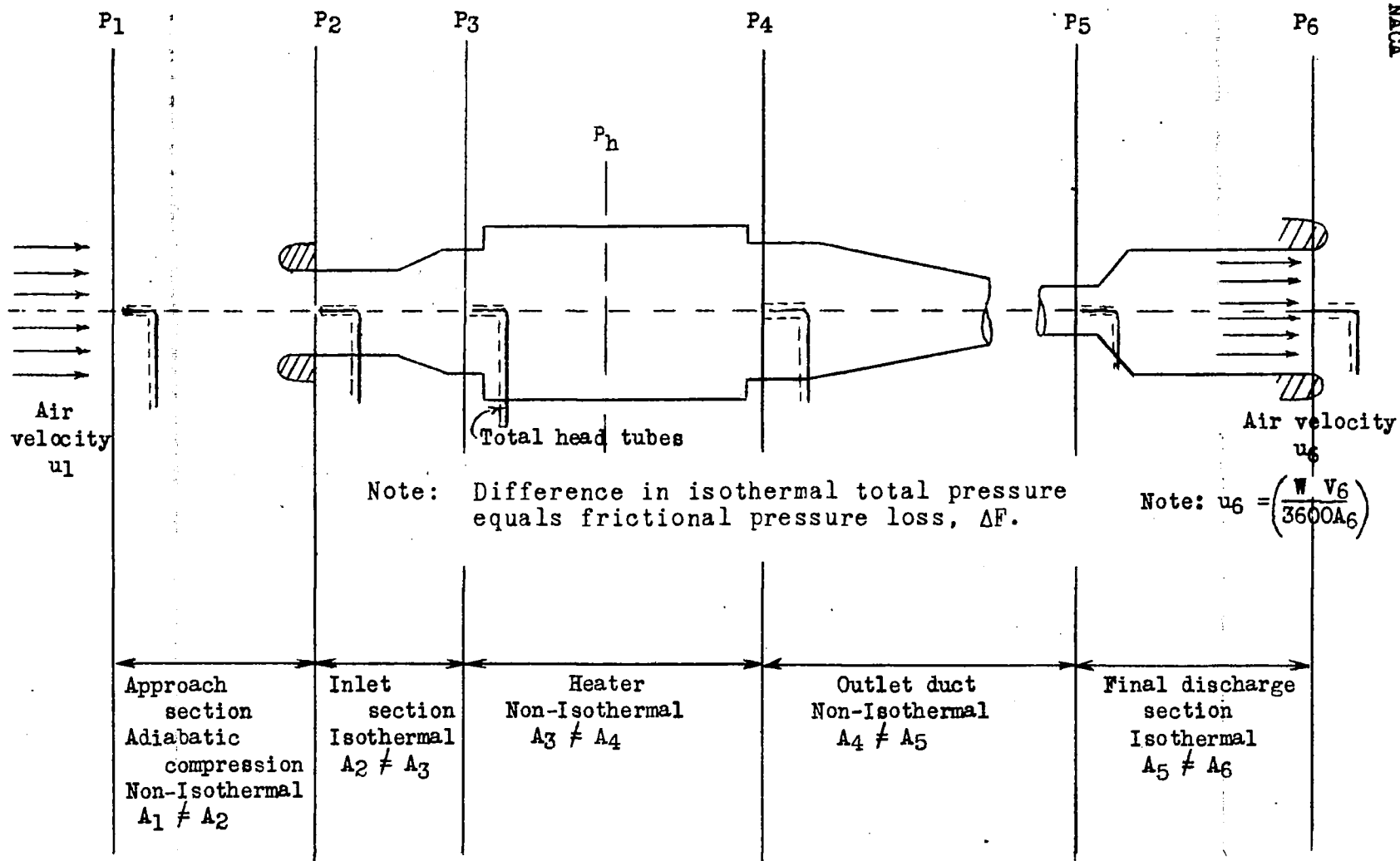

Figure 1.- Elements of heater and duct system.

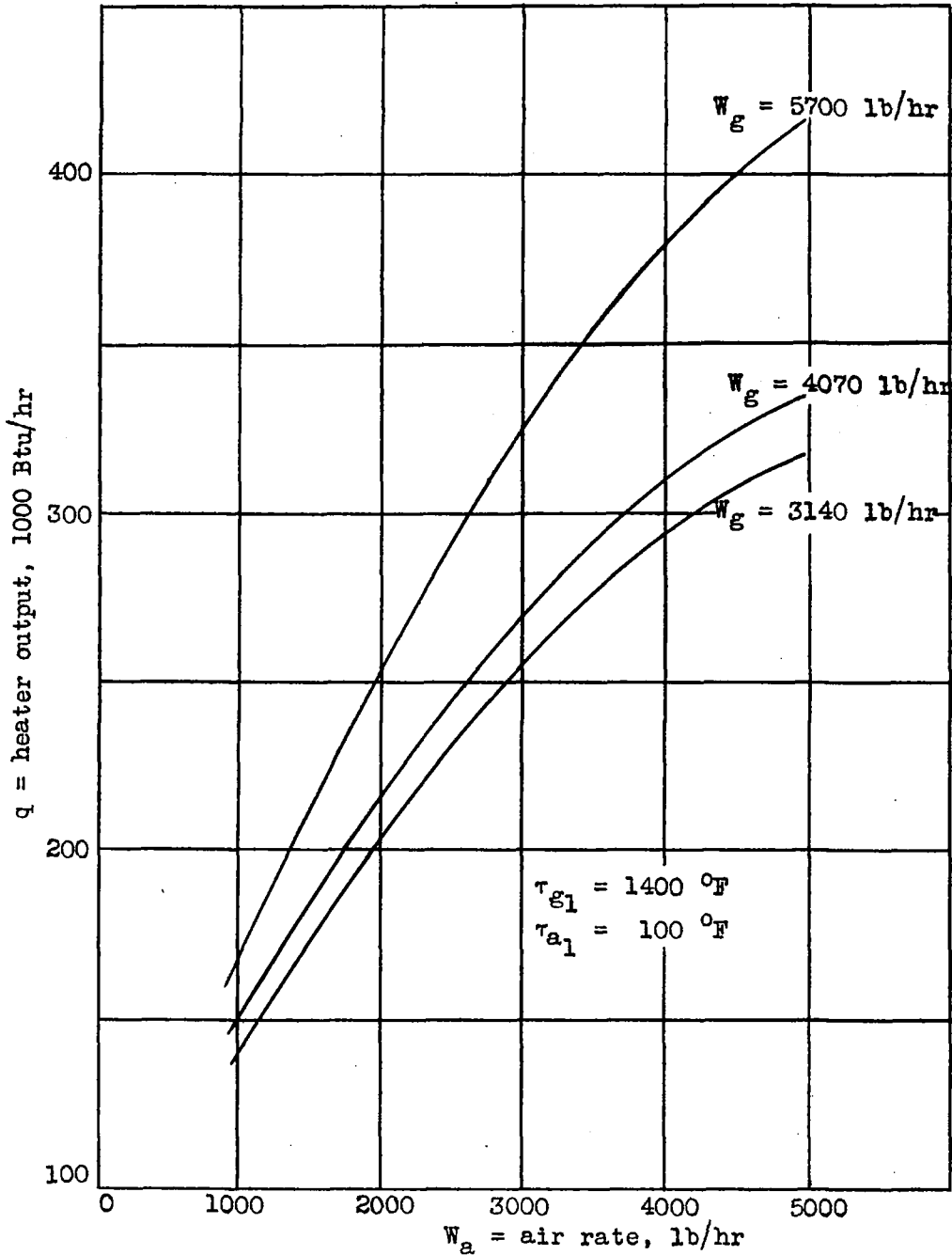

Figure 2.- Thermal output of heater from laboratory data. (The heater output may be estimated by means of the equations presented in reference 3, if laboratory facilities are not available.)

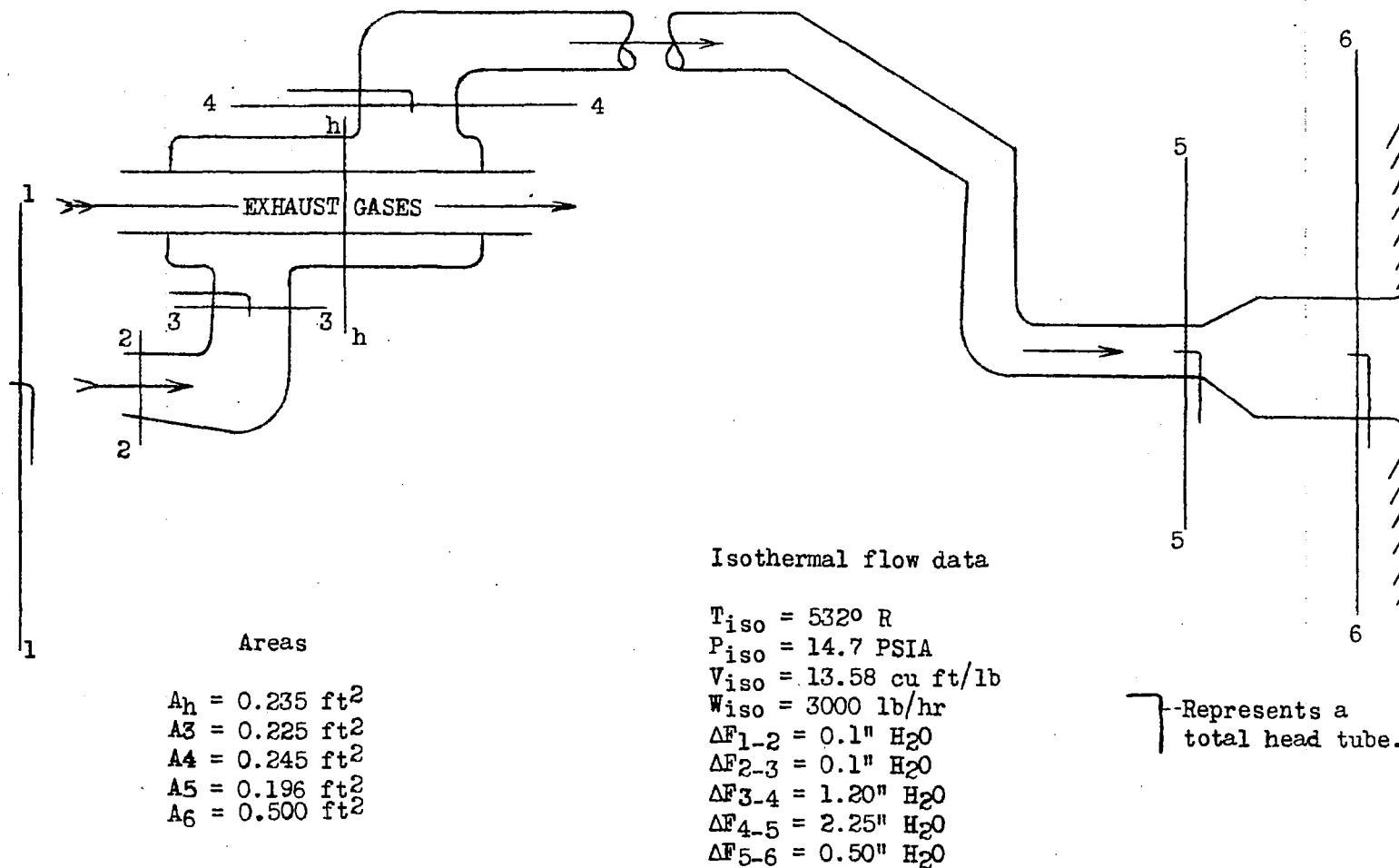

Figure 3.— Isothermal total-pressure drop data for heater and duct system. (The isothermal total-pressure drop may be obtained in the laboratory or may be estimated by means of the data presented in reference 4.)

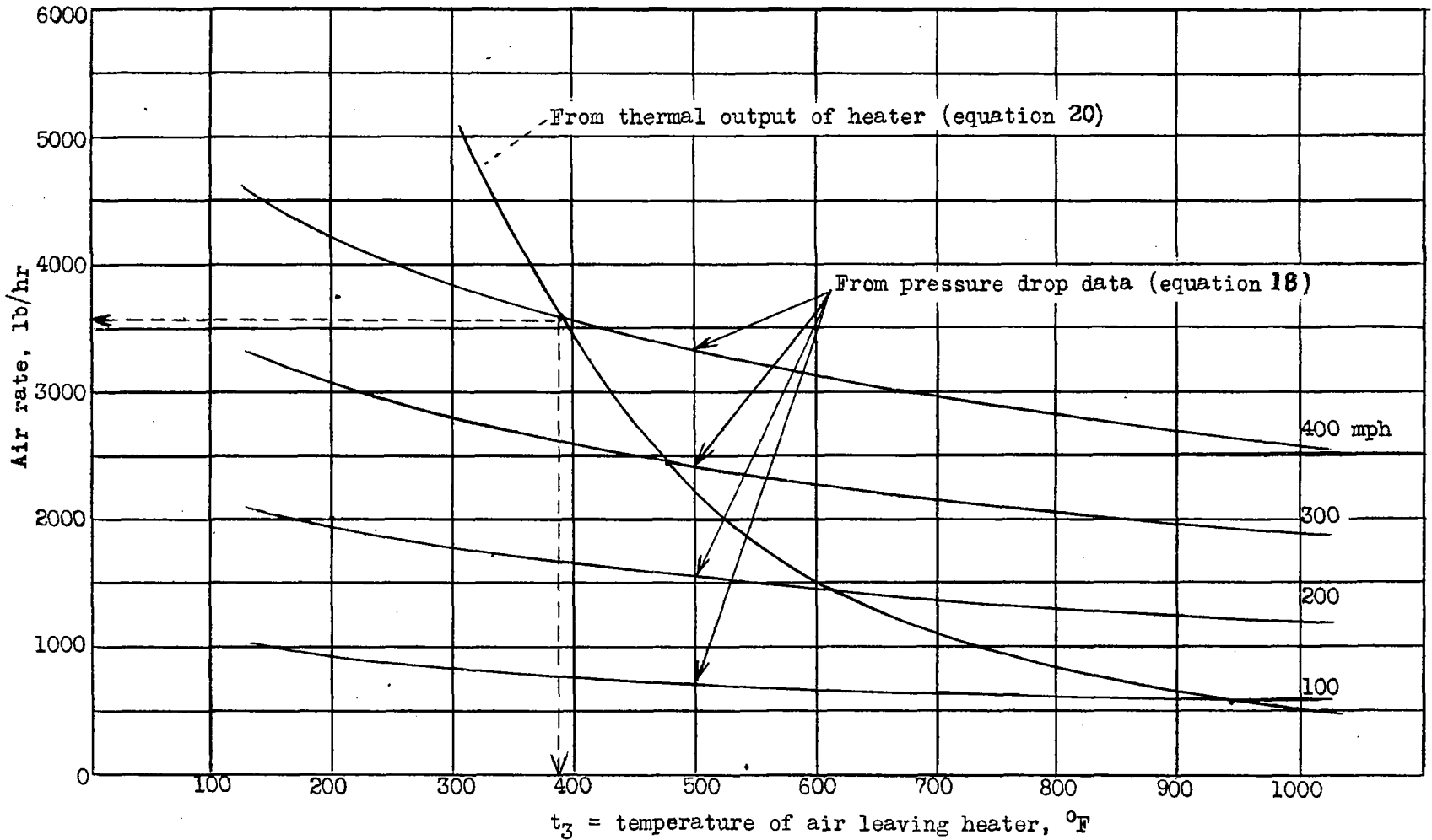

Figure 4.- Curves of  $W$  vs  $t_3$  at an altitude of 30,000 ft from pressure drop data (equation 18.) and from thermal output of heater (equation 20). The intersections of the curves represent the operating points of the heater and duct system at 30,000 ft altitude.

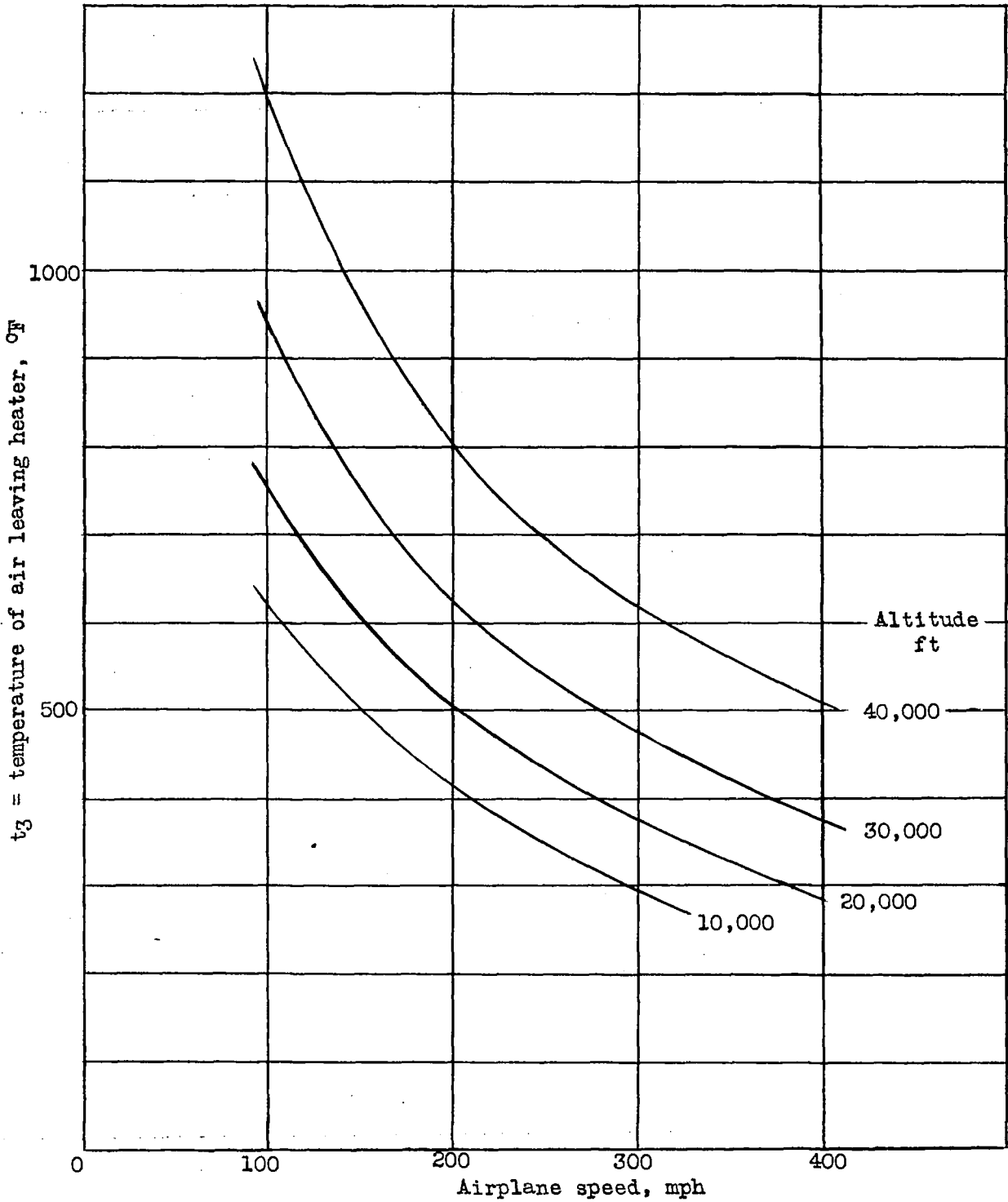

Figure 5.- Temperature of the air leaving the heater at various airplane speeds and altitudes.

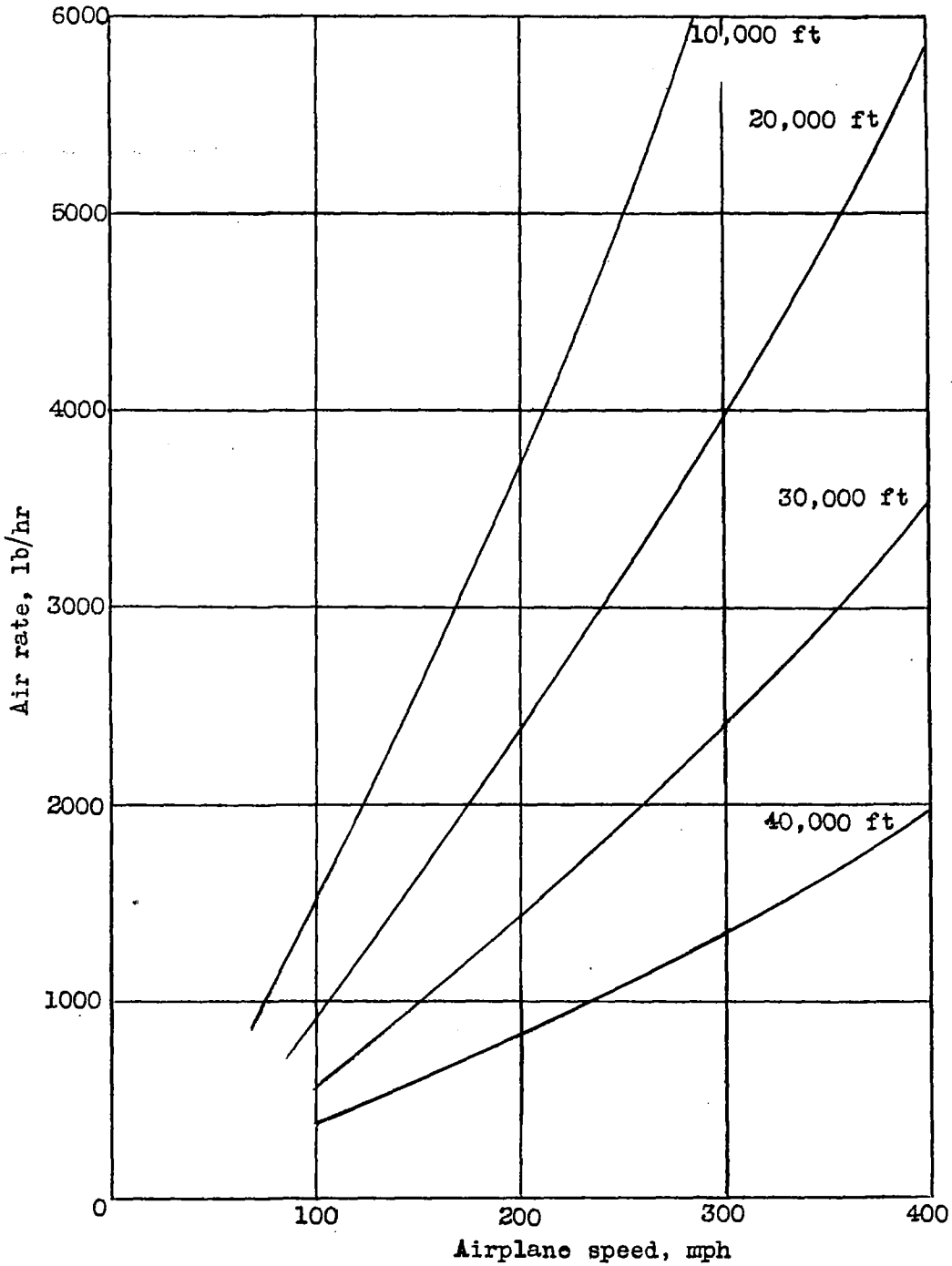

Figure 6.- Ventilating air rate through heater and duct system at various airplane speeds and altitudes.

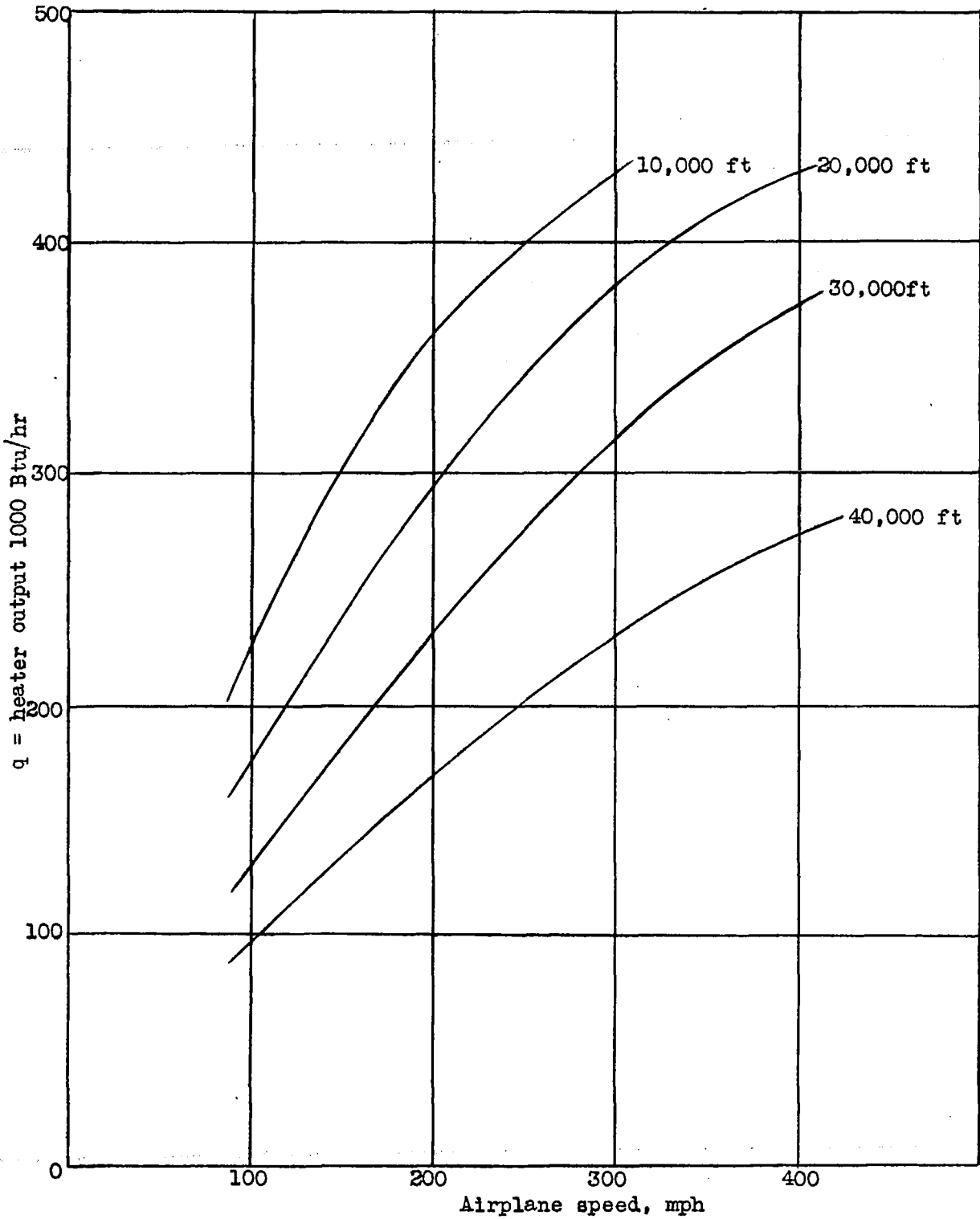

Figure 7.- Thermal output of ram-operated heater as a function of airplane speed and altitude.

TITLE: An Investigation of Aircraft Heaters - XIV - An Air and Heat Flow Analysis of a Ram-Operated Heater and Duct System

AUTHOR(S) : Boelter, L. M. K. Morrin, E. H.

ORIG. AGENCY : University of California, Los Angeles, Calif.

PUBLISHED BY : National Advisory Committee for Aeronautics, Washington, D. C.

ATI- 8143

REVISION

(None)

ORIG. AGENCY NO.

(None)

PUBLISHING AGENCY NO.

ARR-4C01

DATE	DOC. CLASS.	COUNTRY	LANGUAGE	PAGES	ILLUSTRATIONS
March '44	Unclass.	U.S.	English	35	tables, graphs

ABSTRACT:

Graphical method of calculating thermal and aerodynamic performance of heater and duct system for de-icing and cabin heating at any altitude and air speed is outlined. Heat loss from discharge duct, thermal output of heater and isothermal pressure drop through duct system at various air and exhaust gas rates must be known in order to solve equations. Because of limitations of space in aircraft, analysis may not be applicable, although it may be used as a design guide.

DISTRIBUTION: SPECIAL. All requests for copies must be addressed to: Publishing Agency.

DIVISION: Comfortization (23)

SECTION: Air Conditioning (1)

SUBJECT HEADINGS: Heaters, Aircraft (49000)

ATI SHEET NO.: R-23-1-27

Central Air Documents Office

Wright-Patterson Air Force Base, Dayton, Ohio

AIR TECHNICAL INDEX