

MAY 29 1946

# NATIONAL ADVISORY COMMITTEE FOR AERONAUTICS

TECHNICAL NOTE

No. 1056

THE EFFECTS OF VARIOUS PARAMETERS ON THE  
LOAD AT WHICH SPRAY ENTERS THE  
PROPELLERS OF A FLYING BOAT

By John R. Dawson and Robert C. Walter

Langley Memorial Aeronautical Laboratory  
Langley Field, Va.



Washington  
May 1946

LANGLEY MEMORIAL AERONAUTICAL  
LABORATORY  
Langley Field, Va.

"THE EFFECTS OF VARIOUS PARAMETERS ON THE  
LOAD AT WHICH SPRAY ENTERS THE PROPELLERS  
OF A FLYING BOAT"

BY John R. Dawson and Robert C. Walter

May 1946

~~The~~ The propose of this report is to investigate the  
spray characteristics of flying-boat.

The forebody of NACA model 35-A with wing and powered  
propellers had been used.

The resulting of loads against speed with trim curves  
were found ~~to~~ to have minimum points that determined  
the greatest load that could be carried with out spray  
striking the propellers. Load has been used as a dependent

variable in spray investigation.

Either of the two types of spray that emanate from a forebody (pressure and velocity spray) may limit the gross load of a flying boat, depending on the configuration.

Effect of varying power: increase power reduced the load at which spray entered the propellers.

Effect of varying trim: increase trim increased the minimum ~~of~~ load at which pressure spray struck the propellers.

Effect of varying position of propellers: the minimum load at which spray struck the propellers could be varied by changing either the lateral or longitudinal position of the propellers.

The minimum load coefficient at which pressure spray stuck the propellers increased approximately linearly with upward movement of the propeller position.

## NATIONAL ADVISORY COMMITTEE FOR AERONAUTICS

## TECHNICAL NOTE NO. 1056

THE EFFECTS OF VARIOUS PARAMETERS ON THE  
LOAD AT WHICH SPRAY ENTERS THE  
PROPELLERS OF A FLYING BOAT

By John R. Dawson and Robert C. Walter

## SUMMARY

The results of experiments made with a technique for investigating the spray characteristics of flying-boat models are presented. In the method of testing used, the minimum load at which spray strikes powered propellers was determined for a range of speeds and trims. These measured loads were plotted against speed with trim as a parameter, and the resulting curves were found to have minimum points that determined the greatest load that could be carried without spray striking the propellers.

The forebody of a pointed-step flying-boat hull was used for the tests, and the effects of varying trim, propeller position, and amount of power (expressed in terms of disk loading) were investigated.

Either of the two types of spray that emanate from a forebody (pressure or velocity spray) may limit the gross load of a flying boat, depending on the configuration. Increasing the power reduced the load at which spray entered the propellers. Increasing the trim increased the minimum load at which pressure spray struck the propellers but the corresponding load for velocity spray varied erratically with trim. The normal, lateral, and longitudinal positions of the propellers tended to be near the positions that would give the smallest value of the minimum load at which spray struck the propellers. For pressure spray this minimum load increased approximately linearly with upward movement of the propeller position.

## INTRODUCTION

The necessity for keeping the propellers relatively clear of spray imposes a great handicap in reducing the air drag of flying boats. As a result of this requirement, hulls are built larger than other considerations demand - except in the case of large cargo-carrying airplanes in which the volume required for cargo space is greater than the volume needed for a configuration that would provide adequate propeller clearance. Methods for reducing this handicap have been sought for several years and all tank tests have included some observations on spray conditions. Few systematic spray investigations, however, have been conducted in which quantitative data were obtained. In references 1 and 2 data on the variation of spray envelopes were obtained, but the use of these data in design is limited by a lack of quantitative information on the distortion of the spray envelopes by propellers.

Preliminary experiments indicated that it is possible to determine fairly accurately the minimum load at which an appreciable amount of spray strikes the propellers of a powered model running at a given trim and speed. This possibility suggested that using this load as the dependent variable in spray investigations might be feasible; consequently, the procedure was tried in Langley tank no. 2 in tests made with a forebody having a pointed stern. The effects of varying trim, amount of power (expressed in terms of disk loading), and propeller position were determined and the results of these tests are presented herein. The method of testing that is developed can be readily extended to include study of the effects of these parameters on a more conventional forebody than that of the present investigation. The method can be applied also in determining the effects of varying other design parameters.

Although the method of testing is applicable to a complete model configuration (forebody in combination with afterbody), the inclusion of the afterbody would restrict the application of the results. An afterbody can affect the amount of spray in the propellers in normal positions only by its influence on trim and on the percentage of the total load carried by the forebody. The effect on trim must be studied in any case, and the

percentage of the load carried by the forebody must be determined separately if results of forebody-spray investigations are to have the most general application.

Two convenient terms have been adopted to designate the two distinct types of spray that emanate from the side of a planing surface, such as the forebody of a flying-boat hull. One type comes directly from the pressures generated on the bottom of the planing surface and appears chiefly as a curved sheet of water, glassy in appearance. This sheet of water is frequently called the forebody blister. The water that forms this blister and the loose particles associated with it will be referred to as "pressure spray." The second type of spray appears in the region where the planing surface enters the water at the forward edge of the wetted area. This spray, which is in the form of an irregular jet of broken-up water particles, is sometimes called a whisker and will be referred to as "velocity spray."

#### COEFFICIENTS AND SYMBOLS

$C_{\Delta}$	load coefficient ( $\Delta/wb^3$ )
$C_V$	speed coefficient ( $V/\sqrt{gb}$ )
$C_{\Delta P}$	critical load coefficient for pressure spray
$C_{\Delta L}$	lower critical load coefficient for velocity spray
$C_{\Delta U}$	upper critical load coefficient for velocity spray
$w$	specific weight of water, pounds per cubic foot (63.3 for these tests)
$b$	maximum beam of hull, feet
$g$	acceleration of gravity, feet per second per second
$V$	speed, feet per second
$\Delta$	load on water, pounds

- k nondimensional spray coefficient (spray criterion of reference 3)
- r radius of propeller
- h height of hull
- x longitudinal distance from step to plane of propellers, beams
- y lateral distance from center line of model to center line of propeller shaft, beams
- z vertical distance from keel to bottom of propeller circle, beams
- $\tau$  trim of model

#### MODEL

The model used in the tests was the forebody of NACA model 35-A. Model 35-A is one of a series of pointed-step hulls, tests of which are reported in reference 4. This forebody has a constant angle of dead rise of  $20^\circ$  for a distance of 1.7 beams forward of the step, a length-beam ratio of 4, and no chine flare.

The general arrangement of the model, complete with simulated wing and powered propellers, is shown in figure 1. A sheet of plywood was used as a wing because the added complication of a normal wing section did not seem justified; furthermore, keeping the lift of the wing at a minimum was desired because a tare correction was to be made by deducting the lift from the observed loads.

Two 0.9-horsepower direct-current motors were mounted on the wing. Each of these motors drove a three-blade 18-inch-diameter propeller through a gear box. The pitch of the propellers was such that they absorbed the full motor power at approximately 2700 rpm. The propellers both rotated in the same direction.

The model and fittings were so arranged that the position of the wing could be changed either vertically or longitudinally, and several wings were provided so

that the propellers could be placed at a number of pre-selected lateral positions.

#### APPARATUS

A schematic drawing of the test setup is shown as figure 2. The model was attached to a rigid staff that could move only vertically in a roller cage fastened to the towing carriage. A fitting on the end of the staff permitted the trim of the model to be fixed at any desired value. A cable attached to the end of the model staff passed over a sheave and carried a weight pan. Weights could be placed on this pan to counterweigh any desired part of the weight of the model and thus to change the load on the model.

#### TEST PROCEDURE

All the tests were made at constant speeds and fixed trims. At the start of each run a very light load was placed on the model. When the towing carriage had reached the desired constant speed, power was applied to the propellers. The load on the model was then increased until spray reached one of the propellers, and the value of the load at this point was recorded. Under conditions in which the spray to strike the propellers first was velocity spray, the load was further increased until the load at which velocity spray cleared the propellers was determined. Under these conditions, the lightest load at which pressure spray struck the propellers was determined by further increasing the load. The critical load for pressure spray was thus obtained at all test conditions; the upper and lower loads for velocity spray were also obtained whenever they were less than the critical load for pressure spray. Typical photographs showing the spray conditions at which the loads were measured are given as figures 3 to 5.

The critical load for pressure spray was found to check within about  $\pm 5$  percent; the critical loads for velocity spray could not always be determined quite so accurately because of the broken-up character of the spray. In all cases the loads were determined by the

propeller that was moving down as it passed the hull. A slightly greater load was required to cause pressure spray to strike the other propeller, but the effect of the direction of rotation of the propellers on the loads of velocity spray appeared to be within the accuracy of the measurements.

Some lift was obtained from the simplified wing used. This lift was determined for all test conditions and deducted as a tare from the measured loads to give the net loads on the water. *(Tare models were tested with powered propellers)*

When the measured loads were plotted against speed, the curves that were obtained had a minimum point - at a trim of  $0^\circ$  this minimum was not well defined, but this trim is of little practical significance. The tests were made over a sufficient range of speed to determine the minimum points of these curves.

At very low speeds the model could be loaded until the water washed over the bow without any appreciable spray entering the propeller disks. The highest speed at which this condition could be found was designated the bow-wash limit.

Trims of  $0^\circ$ ,  $3^\circ$ ,  $6^\circ$ ,  $9^\circ$ , and, for some configurations,  $12^\circ$  were tested. This range of trim covers the range found for conventional hulls at speeds in which spray is critical. Trim was measured with respect to the straight part of the keel forward of the step.

The effect on pressure spray of varying power was determined by making tests with no power, one-half power, and full power applied to the propellers. One-half power was obtained by reducing the current input to the motors until the product of current and voltage was one-half that at full power. In the tests with no power the load that caused the blister to touch a propeller blade in its lowest position was measured.

In order to express the effect of power in terms of the more general parameter disk loading, the static thrust at one-half and full power was measured with a dead-weight dynamometer. These values of thrust were divided by the propeller-disk area to give disk loadings in terms of pounds of static thrust per square foot of disk area. The static thrust was used because the effect

of speed on thrust would be small in the speed range covered in these tests.

The propeller speed used in the tests would ordinarily be used for a very large scale model; however, a check test was made with a propeller of the same diameter but of such pitch as to absorb the full power of the motor at 3600 rpm instead of at 2700 rpm. The check test showed that this variation in propeller speed did not affect the results if power and propeller diameter were held constant.

The following table gives the propeller positions tested. (See also fig. 1.) Dimensions are given in multiples of the maximum beam  $b$  of the model.

Longitudinal distance from step to plane of propellers, $x$ (beams)	Lateral distance from center line of model to center line of propeller shaft, $y$ (beams)	Vertical distance from keel to bottom of propeller circle, $z$ (beams)
1.66	1.50	0.50
1.66	1.50	.75
1.66	1.50	1.00
2.12	1.50	.75
1.20	1.50	.75
1.66	1.25	.75
1.66	2.00	.75
1.66	2.00	.50

## RESULTS AND DISCUSSION

The data from the tests were all reduced to the usual coefficients based on Froude's law. The load coefficient at which pressure spray struck the propellers is designated  $C_{\Delta P}$  (critical load coefficient for pressure spray).

The lowest load coefficient at which velocity spray struck the propellers at a given speed is designated  $C_{\Delta L}$  (lower critical load coefficient for velocity spray), and the highest load coefficient at which velocity spray struck the propellers at the same speed is designated  $C_{\Delta U}$  (upper critical load coefficient for velocity spray).

Figure 6 is an illustrative figure that presents typical curves of  $C_{\Delta P}$ ,  $C_{\Delta U}$ , and  $C_{\Delta L}$  plotted against  $C_V$ . The minimum values for  $C_{\Delta P}$  and  $C_{\Delta L}$  given by these curves are designated  $C_{\Delta P_{min}}$  and  $C_{\Delta L_{min}}$ .

All results of the tests are given in figures 7 to 14 in which  $C_{\Delta P}$ ,  $C_{\Delta L}$ , and  $C_{\Delta U}$  are plotted against speed coefficient  $C_V$  with trim as a parameter. In figure 8, the propeller-disk loading (ratio of static thrust to propeller-disk area) is also included as a parameter.

All the curves for pressure spray  $C_{\Delta P}$  with the exception of those at a trim of  $0^\circ$  have a pronounced minimum value that occurs between speed coefficients of 1.5 and 2.5. In general, the minimum value for velocity spray  $C_{\Delta L_{min}}$  is shown by these figures to be less than the minimum value for pressure spray  $C_{\Delta P_{min}}$ ; exceptions occur at low trims for all positions of the propellers and at all trims for the highest position of the propellers. The curves show that for a given speed there is a definite range of load coefficient in which velocity spray strikes the propellers; either above or below this range the velocity spray will clear the propellers. As load on the model was increased, the velocity spray approached the propeller from behind until the spray entered the propeller disk on the inboard side. A further increase in load was possible up to a value at which the water line was so far forward that the velocity spray would again clear the propellers by passing them on the outboard side. The amount of spray passing through the propeller disks varied throughout this load range; that is, the spray was light at both the lower and upper load limits and reached a maximum at some load between these limits. The spray in the propellers at either the lower or upper critical load coefficient for velocity spray  $C_{\Delta L}$  or  $C_{\Delta U}$  was less severe than at the critical load coefficient for pressure spray  $C_{\Delta P}$ .

The curves show that a substantial gain in load capacity can be obtained if chine flare is effective in raising the minimum value of load in which velocity spray might be troublesome to a value above that for  $C_{\Delta P_{min}}$ .

The data given in reference 5 indicate that chine flare can usually control velocity spray; therefore,  $C_{\Delta P_{min}}$  becomes the critical value that usually determines the load capacity of the hull. Under such a condition,  $C_{\Delta P_{min}}$  represents the greatest load that can be carried without spray striking the propellers.

#### Effect of Varying Power

The effect of varying power on  $C_{\Delta P}$  is shown in figure 8 in which power is expressed in terms of disk loading - also in figure 15 in which  $C_{\Delta P_{min}}$  is plotted against propeller-disk loading. For a typical trim of  $6^\circ$  figure 15 shows that application of full power reduces  $C_{\Delta P_{min}}$  approximately 22 percent. About two-thirds of this reduction was obtained with one-half power. These results agree with the observations of reference 6. The percent reduction of  $C_{\Delta P_{min}}$  caused by power tended to increase with increasing trim.

Although the effect on  $C_{\Delta L}$  and  $C_{\Delta U}$  of varying power was not measured, observation showed the effect to be generally similar to that on  $C_{\Delta P}$ .

#### Effect of Varying Trim

The effect of varying trim can be seen in figures 15 to 18. These figures show that  $C_{\Delta P_{min}}$  increases with increasing trim but at a decreasing rate of change. Increasing the trim from  $6^\circ$  to  $9^\circ$  gave an average increase

in  $C_{\Delta P_{min}}$  of about 0.05 or approximately 3 percent per degree increase in trim. The speed coefficient at which  $C_{\Delta P_{min}}$  occurred tended to decrease with increasing trim. (See figs. 7 to 14.)

The effect of trim on velocity spray was less consistent than the effect of trim on pressure spray. In general, however, the highest values for  $C_{\Delta L_{min}}$  were obtained at a trim of  $6^\circ$ , and lower values were obtained at both higher and lower trims. (See figs. 16 to 18.) The speed coefficients at which  $C_{\Delta L_{min}}$  occurred also

tended to decrease with increasing trim. These results indicate that if velocity spray is adequately controlled by chine flare an increase in the limit imposed by spray on the gross load might be obtained by increasing the trim of a flying-boat hull in the speed range below hump speed. On this basis, a slight reduction in the size of a flying-boat hull might be obtained by increasing the trim at low speeds, but only about 1 percent decrease in planform dimensions could be obtained for each degree of increase in trim. This decrease however is too small to warrant much consideration in design.

#### Effect of Varying Position of Propellers

Effect of longitudinal position.- The effect of varying the longitudinal position of the propellers is shown in figure 16 in which  $C_{\Delta P_{min}}$  and  $C_{\Delta L_{min}}$  are plotted against the distance  $x$ , in beams, of the propellers forward of the step. Of the three positions tested (1.20b, 1.66b, and 2.12b), the lowest value of  $C_{\Delta P_{min}}$  for all trims was obtained with the propeller at 1.66b forward of the step. The indications are that as trim is increased the longitudinal position of the propellers for the minimum value of  $C_{\Delta P_{min}}$  moves aft slightly.

At a trim of  $6^\circ$ , moving the propellers forward  $1/2$  beam from the most adverse position for pressure spray would allow an increase in  $C_{\Delta}$  of about 15 percent.

At trims of  $6^\circ$  and  $9^\circ$ ,  $C_{\Delta L_{\min}}$  increased at an increasing rate as the propellers were moved forward. At a trim of  $3^\circ$ ,  $C_{\Delta L_{\min}}$  varied in about the same manner as  $C_{\Delta P_{\min}}$  and the difference in magnitude between the two was very small.

Normal operating trims in the speed range under consideration are above  $3^\circ$ . At these trims, the indications are that the most forward position at which the propellers can be placed would result in the least difficulty with both pressure and velocity spray. The possibilities of the advantage of this trend, however, are limited by balance considerations for the airplane.

Effect of lateral position. - The effect of changing the lateral position of the propellers is shown in figure 17 in which  $C_{\Delta P_{\min}}$  and  $C_{\Delta L_{\min}}$  are plotted against the distance  $y$ , in beams, from the center line of the model to the center line of the propeller shaft. The curves of  $C_{\Delta P_{\min}}$  tend to have a minimum point and the lateral position of the propellers at which this minimum occurs tends to move outboard with increasing trim. At a trim of  $6^\circ$ ,  $C_{\Delta P_{\min}}$  is increased about 15 percent as the propellers are moved  $1/2$  beam outboard from the position of minimum load.

The way in which  $C_{\Delta L_{\min}}$  varies with lateral position of the propellers is affected greatly by trim. At a trim of  $3^\circ$ , the curve for  $C_{\Delta L_{\min}}$  has a minimum point whereas the curves at trims of  $6^\circ$  and  $9^\circ$  have a maximum point.

At a normal trim of  $6^\circ$ , chine flare appears to be important in order to control velocity spray if the propellers are placed either close inboard or far outboard. If, however, velocity spray is controlled by chine flare, the least difficulty with spray will be obtained by placing the propellers as far outboard as possible.

Effect of vertical position.- The effect of varying the vertical position of the propellers is shown in figure 18 in which  $C_{\Delta P_{min}}$  and  $C_{\Delta L_{min}}$  are plotted against the distance  $z$ , in beams, between the keel and the bottom of the propeller circle. The variation of  $C_{\Delta P_{min}}$  with  $z$  is nearly linear and the slope of the curve increases with increasing trim.

The value of  $C_{\Delta L_{min}}$  increases with increasing values of  $z$  (increasing propeller clearance); but with a distance  $z$  of more than about  $0.90b$ ,  $C_{\Delta L_{min}}$  is greater than  $C_{\Delta P_{min}}$  and is, therefore, of no significance. The indications are that with large propeller clearances chine flare is not needed to control velocity spray.

The curves of figure 18 can be used to show the effect of the vertical distance  $z$  on the size of forebody required to carry a given load if the spray coefficient  $k$  of reference 3 is assumed to give a valid relation between forebody length and beam for given spray characteristics.

For purposes of illustration, a forebody (similar to the one tested) is assumed to carry a load of 36,500 pounds and the trim in the critical spray region is assumed to be  $6^\circ$ . From figure 18, a value of  $C_{\Delta} = 0.57$  is obtained for a vertical distance  $z_1$  of  $1.00b_1$ . The beam  $b_1$  required for this load is 10 feet and the radius of the propellers  $r$  is  $0.69b_1$  or 6.9 feet. If the hull is faired in such a way that its top is at the level of the propeller shafts, the height of the hull  $h_1$  will be

$$\begin{aligned} h_1 &= z_1 + r \\ &= 10.0 + 6.9 \\ &= 16.9 \text{ feet} \end{aligned}$$

Therefore

$$b_1 h_1 = 169 \text{ square feet}$$

and

$$b_1 + h_1 = 26.9 \text{ feet}$$

If the vertical distance were decreased to  $z_2 = 0.90b_1$  and the propeller radius were to remain 6.9 feet, the height would become

$$\begin{aligned} h_2 &= 9.0 + 6.9 \\ &= 15.9 \text{ feet} \end{aligned}$$

and the load coefficient would be reduced to a value  $C_\Delta = 0.527$  (fig. 18). If no changes in forebody planform dimensions were made, the load would then have to be reduced to 33,700 pounds. If, instead of reducing the load, the load were held constant at 36,500 pounds by increasing the beam - the forebody length  $L_f$  to remain constant - the value to which the beam must be increased can be obtained from equation (2) of reference 3

$$k = \frac{\Delta}{wbL_f^2}$$

which may be written

$$\frac{\Delta}{b} = kwL_f^2$$

For a given position of the propellers and for given spray characteristics,  $k$  will remain constant. Since in the present case it is also desired to hold  $w$  and  $L_f$  constant, all the values on the right hand side of this equation are constant, and for  $z_2 = 9.0$

$$\begin{aligned} kwL_f^2 &= \frac{\Delta 33,700}{b_1} \\ &= \frac{33,700}{10} \\ &= 3370 \end{aligned}$$

The given spray conditions can be maintained by keeping the ratio of the load to the beam equal to 3370 as long as no other changes in the configuration are made. These

spray conditions will also be the same as those obtained with a load of 36,500 pounds when  $b_1 = 10$  and  $z_1 = 10.0$ . In order to keep these same spray conditions with a value of  $z_2 = 9.0$  but for a load of 36,500 pounds

$$\frac{\Delta 36,500}{b_2} = 3370$$

or

$$b_2 = \frac{36,500}{3370}$$

$$= 10.83 \text{ feet}$$

Therefore

$$b_2 h_2 = 172 \text{ square feet}$$

and

$$b_2 + h_2 = 26.73 \text{ feet}$$

Similar calculations were made for other values of vertical distance by use of the curves of figure 18 at a trim of  $6^\circ$  for both pressure and velocity spray. The same calculations were also made for a gross load of 29,400 pounds. The results of these calculations are plotted in figure 19 in nondimensional form where

$bh\left(\frac{w}{\Delta}\right)^{2/3}$  and  $(b+h)\left(\frac{w}{\Delta}\right)^{1/3}$  are plotted against

$(h-r)\left(\frac{w}{\Delta}\right)^{1/3}$ . The product  $bh$  is proportional to the

frontal area of the hull, and the sum  $b+h$  is proportional to the periphery or, for a hull of constant length, is proportional to the skin area.

Figure 19 shows that if the propellers are placed low, both the periphery and frontal area must be very large if velocity spray is not controlled. The curves for pressure spray show that the frontal area of the hull tends to decrease as the propellers are moved up, but moving the propellers vertically has less effect on the periphery of the hull than on frontal area. The periphery tends to be a minimum at some value of  $(h - r) \left( \frac{w}{\Delta} \right)^{1/3}$

that apparently varies with the gross load. Since the effect on frontal area is so much greater than on periphery, the indications are that less air drag will be obtained by placing the propellers high and using a relatively narrow hull than by placing the propellers low and using a wide hull. If the propellers are placed sufficiently high, velocity spray will not impose a limitation on load and it should be possible to omit chine flare and thereby to obtain a further reduction in air drag.

#### Spray Limitations in Service

In service, a certain amount of spray can be tolerated by the propellers of a flying boat during take-off. The amount that can be tolerated is affected by types and materials of propellers, cost and time for replacing them, roughness of water, tactical and operational requirements, and other similar factors. Even the ratio of thrust to water resistance has an appreciable effect because of the way the ratio affects the time required to accelerate through the range of speed in which bad spray conditions occur. Although increasing the thrust tends to decrease the minimum load at which spray strikes the propellers, the resultant increase in acceleration may be sufficient to permit an actual increase in the load permissible for take-off. The effect of factors such as these on acceptable gross loads can be determined from operating experience. These effects can be evaluated in the form of increments of load to be added to or deducted from the minimum load at which spray strikes the propellers.

## CONCLUSIONS

An investigation to determine the effects of various parameters on the load at which spray enters the propellers of a flying boat resulted in the following conclusions:

1. The lightest load at which spray strikes the propellers of a powered model when under way can be determined with sufficient accuracy to permit the use of this load as a dependent variable in spray investigations of flying boats.
2. Either of the two types of spray that emanate from a forebody (pressure or velocity spray) may limit the gross load of a flying boat, depending on the configuration. At high trims and high propeller positions pressure spray will be the limiting factor even if no chine flare is used to control velocity spray.
3. Increasing power reduced the load at which spray entered the propellers of a flying boat although the resultant increase in acceleration might be sufficient to permit take-offs at greater gross loads without spray difficulties.
4. Increasing trim increased the minimum load at which pressure spray struck the propellers. The minimum load at which velocity spray struck the propellers varied erratically with trim, but tended to be greatest near a trim of  $6^{\circ}$ .
5. The minimum load at which spray struck the propellers could be varied by changing either the lateral or longitudinal position of the propellers. Because of other considerations the normal positions of the propellers tended to be near the positions that would give the smallest value of this minimum load.
6. The minimum load coefficient at which pressure spray struck the propellers increased approximately

linearly with upward movement of the propeller position; the rate of increase became larger with increasing trim.

Langley Memorial Aeronautical Laboratory  
National Advisory Committee for Aeronautics  
Langley Field, Va., February 20, 1946

#### REFERENCES

1. Sottorf, W.: Experiments with Planing Surfaces.  
NACA TM No. 739, 1934.
2. Locke, F. W. S., Jr., and Bott, Helen L.: A Method for Making Quantitative Studies of the Main Spray Characteristics of Flying-Boat Hull Models.  
NACA ARR No. 3K11, 1943.
3. Parkinson, John B.: Design Criteria for the Dimensions of the Forebody of a Long-Range Flying Boat.  
NACA ARR No. 3K08, 1943.
4. Dawson, John R.: Tank Tests of Three Models of Flying-Boat Hulls of the Pointed-Step Type with Different Angles of Dead Rise - N.A.C.A. Model 35 Series.  
NACA TN No. 551, 1936.
5. Bell, Joe W., and Olson, Roland E.: Tank Tests to Determine the Effects of the Chine Flare of a Flying-Boat Hull - N.A.C.A. Model Series 62 and 69.  
NACA TN No. 725, 1939.
6. Parkinson, John B., and Olson, Roland E.: Tank Tests of a 1/5 Full-Size Dynamically Similar Model of the Army OA-9 Amphibian with Motor-Driven Propellers - NACA Model 117. NACA ARR, Dec. 1941.

x (beams)	y (beams)	z (beams)
1.66	1.50	0.50
1.66	1.50	.75
1.66	1.50	1.00
2.12	1.50	.75
1.20	1.50	.75
1.66	1.25	.75
1.66	2.00	.75
1.66	2.00	.50

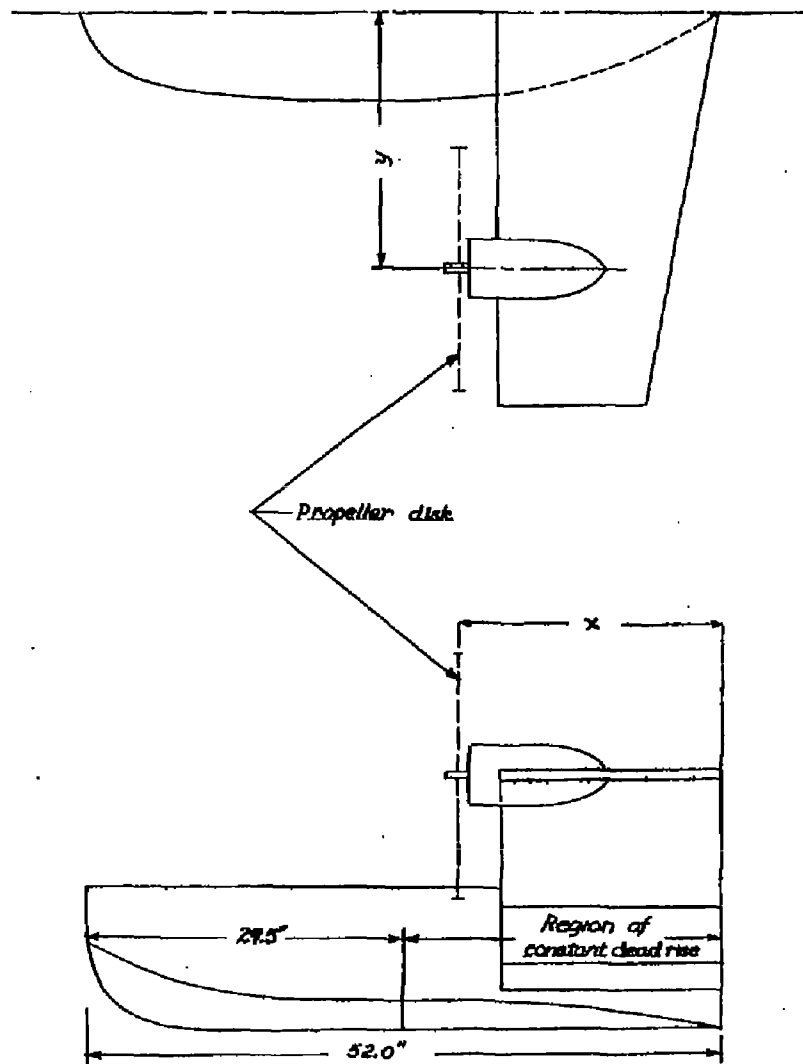
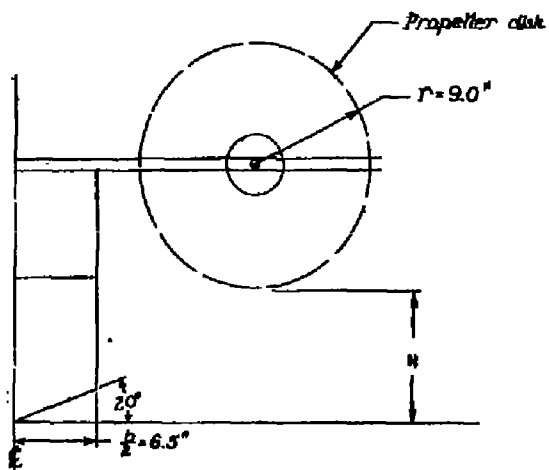
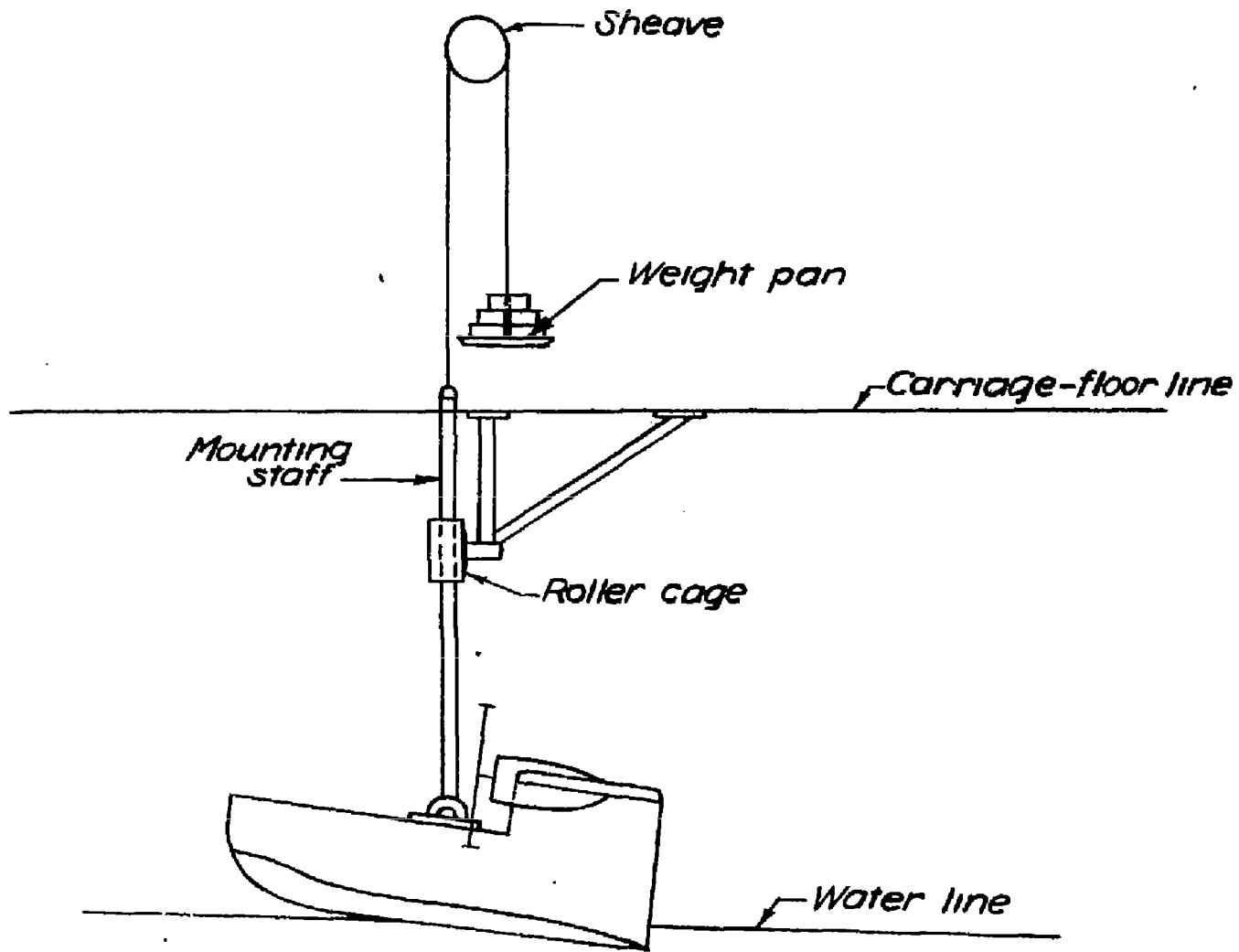

Figure 1. - General arrangement of model.

NATIONAL ADVISORY  
 COMMITTEE FOR AERONAUTICS



NATIONAL ADVISORY  
COMMITTEE FOR AERONAUTICS

Figure 2. - Test setup.



(a) Full power.



(b) No power.

Figure 3.- Spray photographs of model at critical load for pressure spray with full power and at the same load with no power.  $C_{\Delta} = 0.484$ ;  $C_V = 2.03$ ;  $\tau = 6^{\circ}$ .

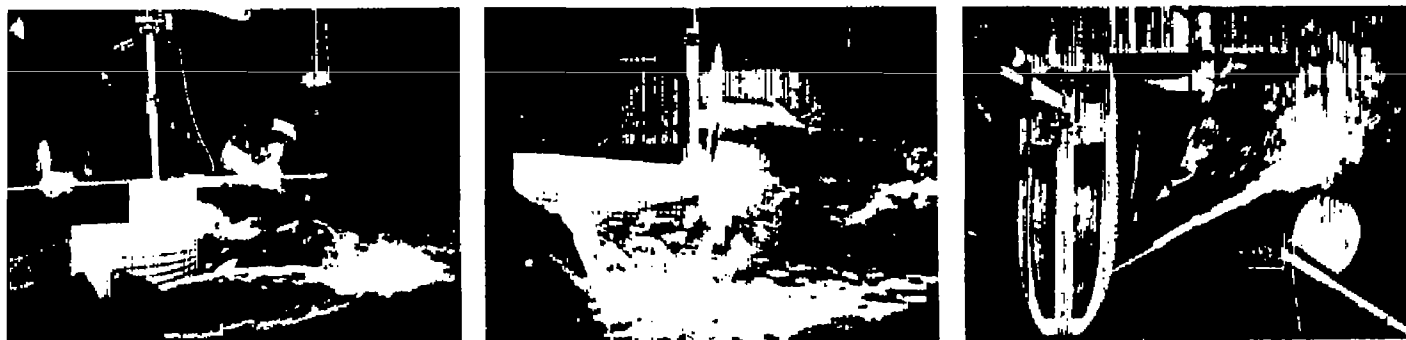

(a) One-half power.



(b) No power.

Figure 4.- Spray photographs of model at critical load for pressure spray with half power and at the same load with no power.  $C_{\Delta} = 0.533$ ;  $C_V = 2.03$ ;  $\tau = 6^{\circ}$ .

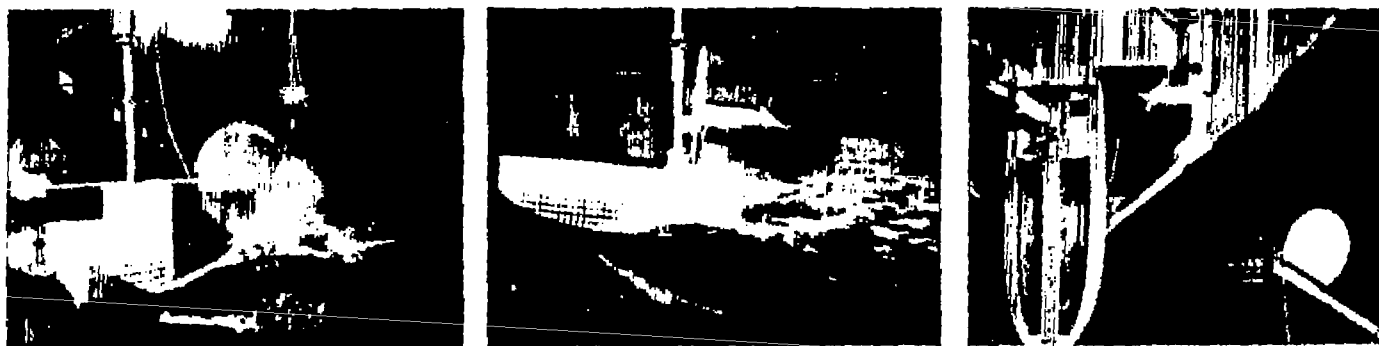

(a) Lower critical load.

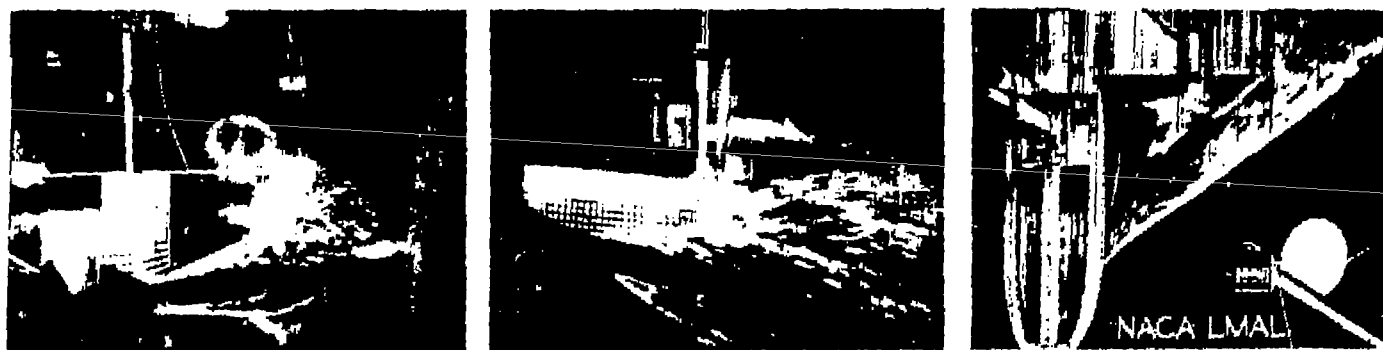

(b) Upper critical load.

Figure 5.- Spray photographs of model at lower and upper critical loads for velocity spray with full power.

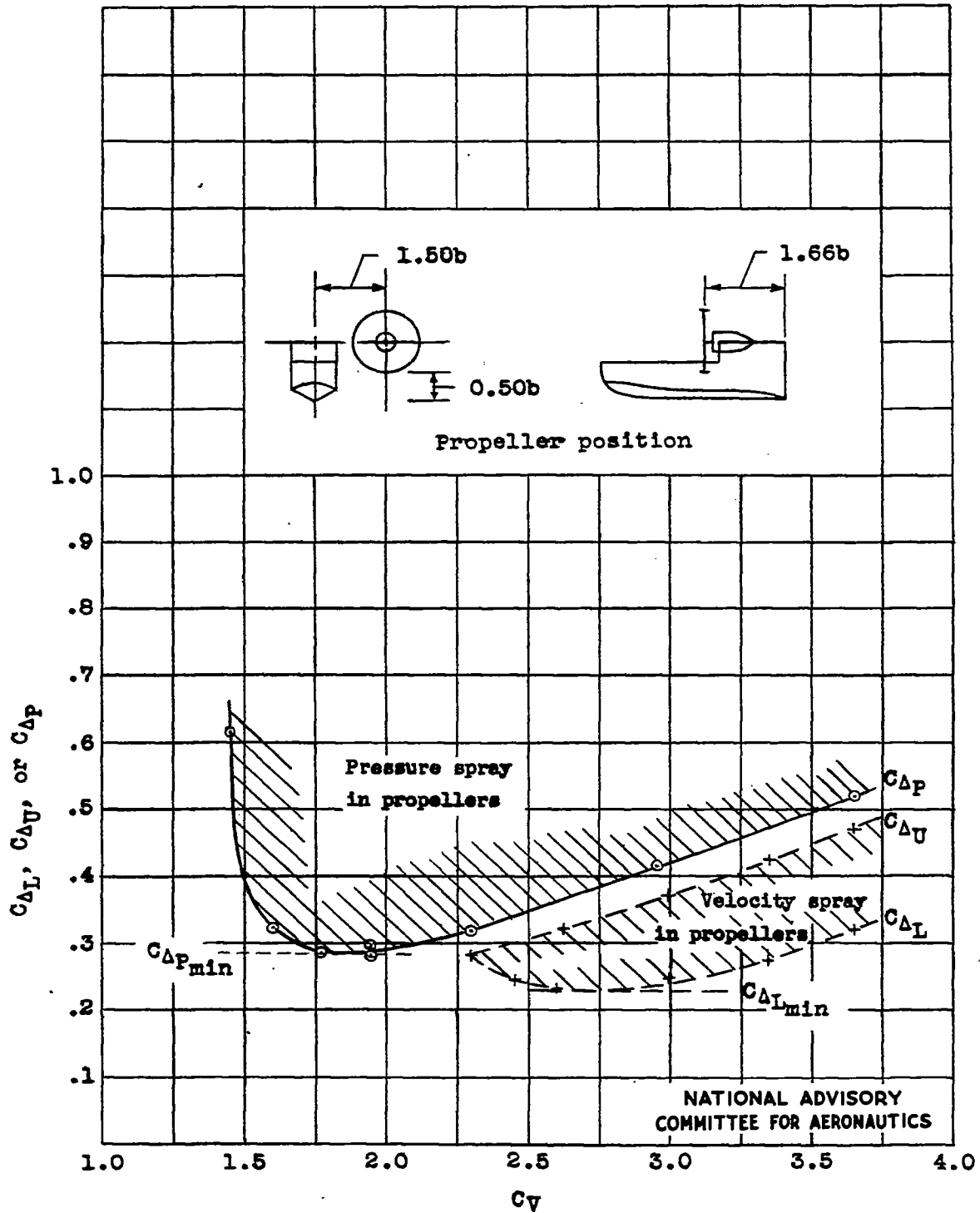

Figure 6.- Typical curves illustrating the coefficients used.

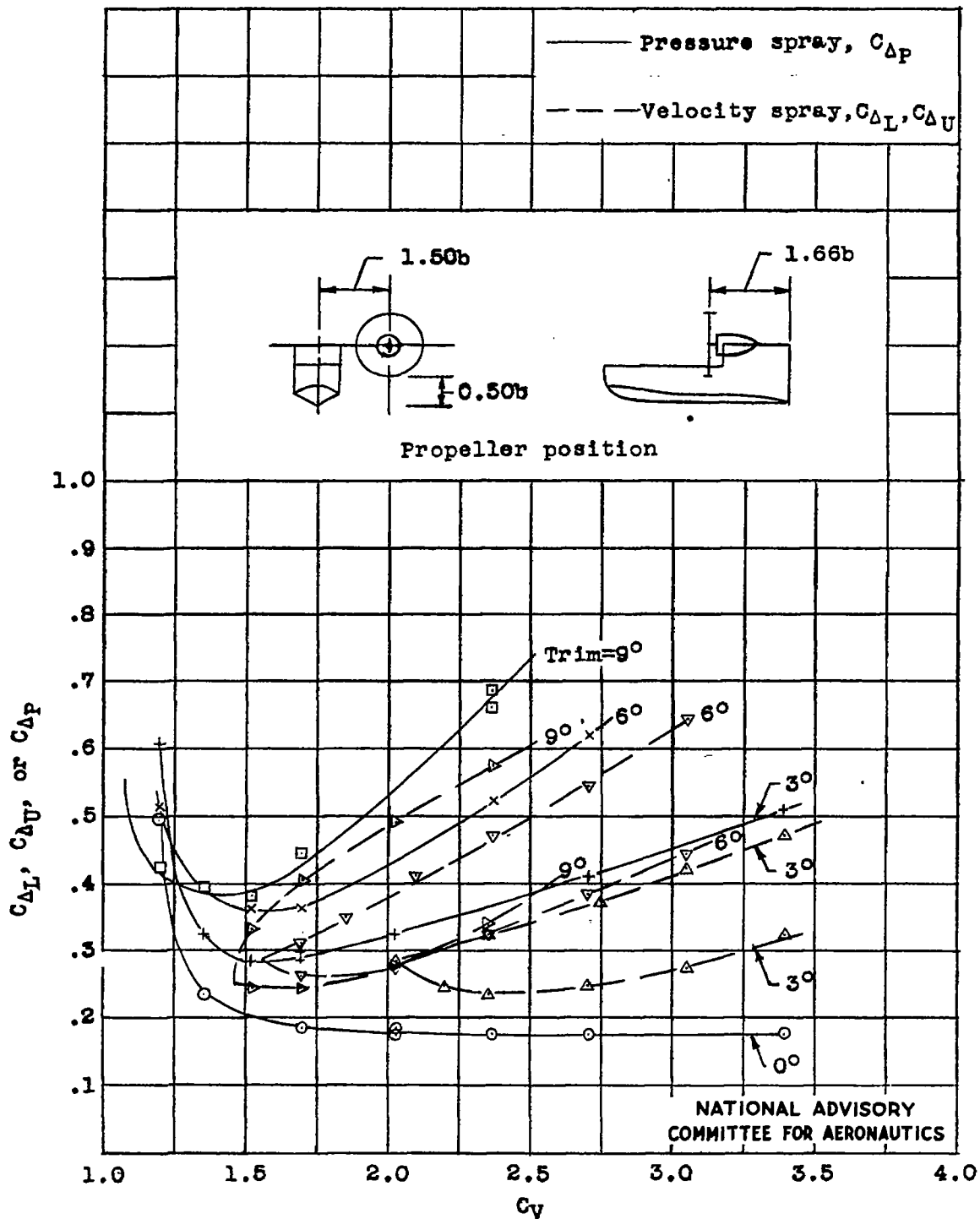

Figure 7.- Variation of critical load coefficient for spray with speed coefficient at various trims.  
 $x = 1.66b$ ;  $y = 1.50b$ ;  $z = 0.50b$ .

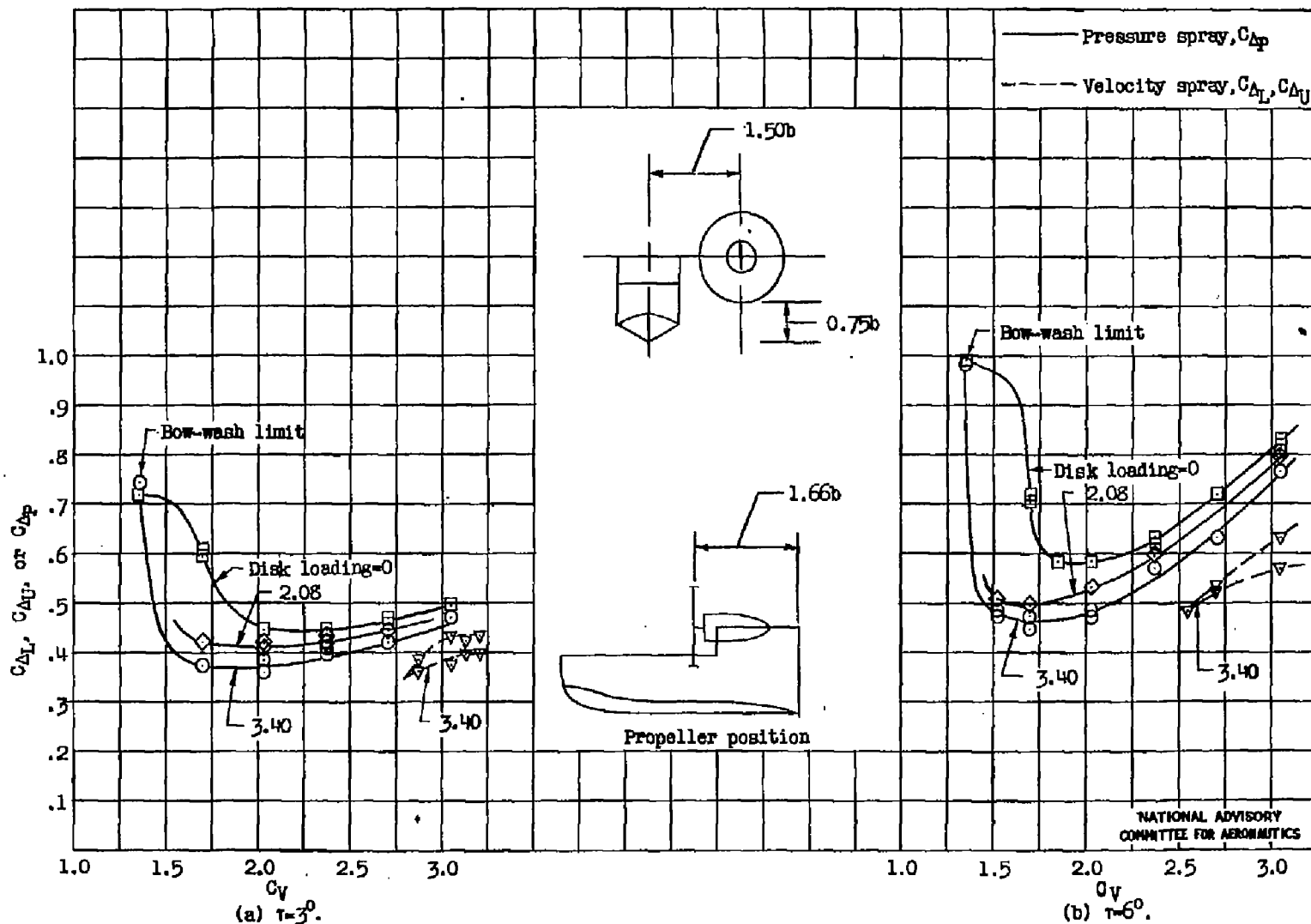

Figure 8.- Variation of critical load coefficient for spray with speed coefficient at various trims for three disk loadings.  $x = 1.66b$ ;  $y = 1.50b$ ;  $z = 0.75b$ .

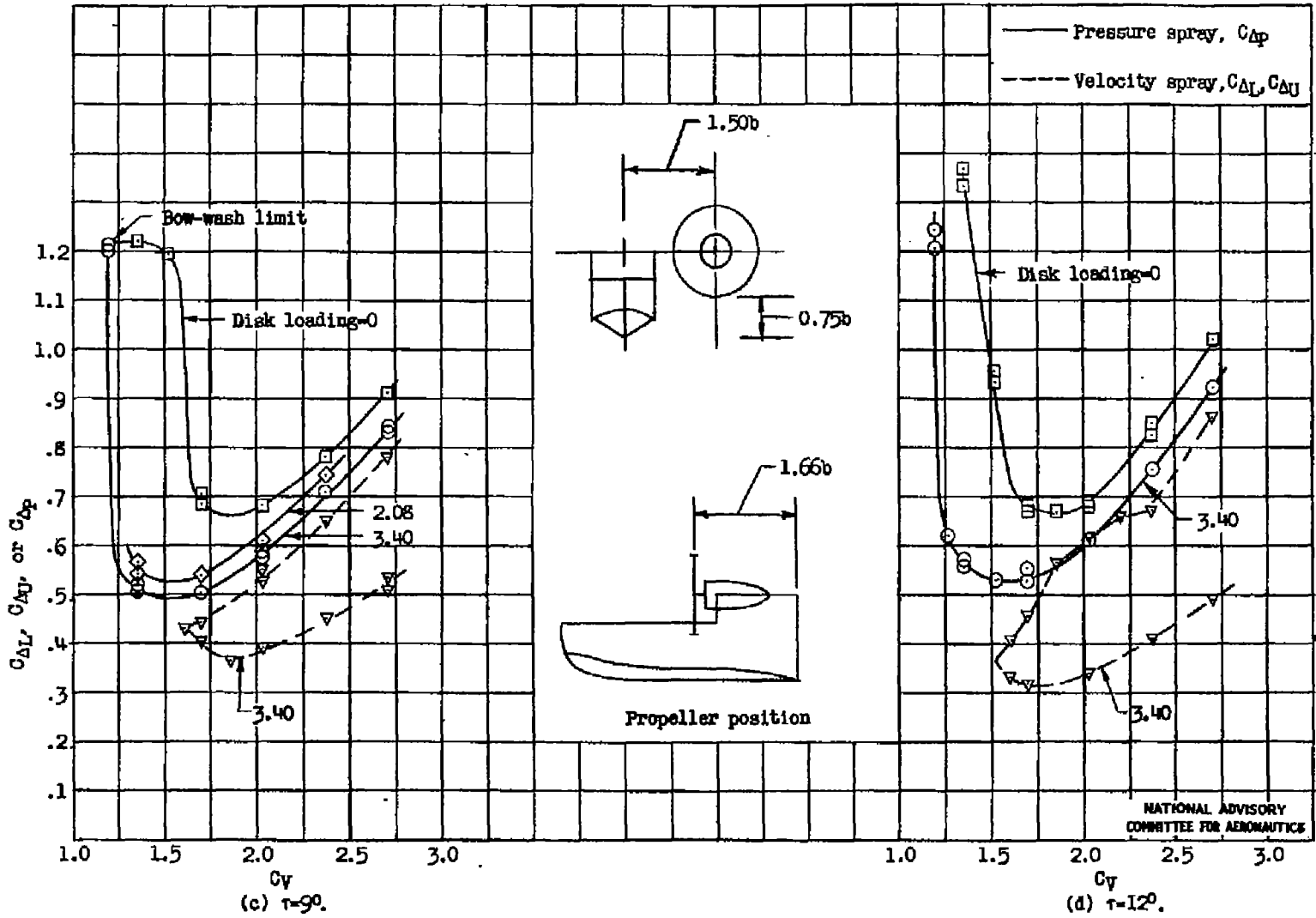

Figure 8.- Concluded.

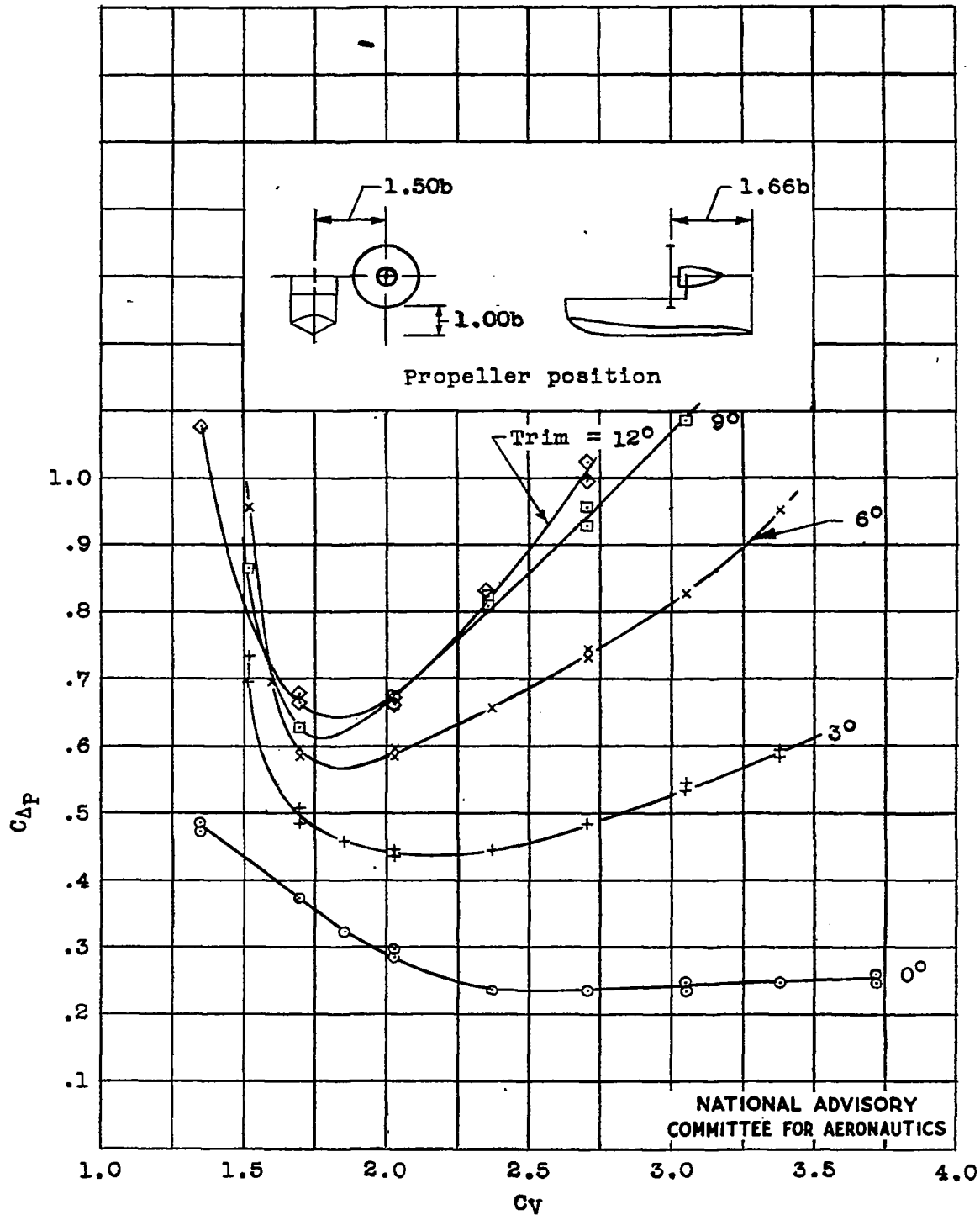

Figure 9.- Variation of critical load coefficient for pressure spray with speed coefficient at various trims.

$x = 1.66b$ ;  $y = 1.50b$ ;  $z = 1.00b$ .

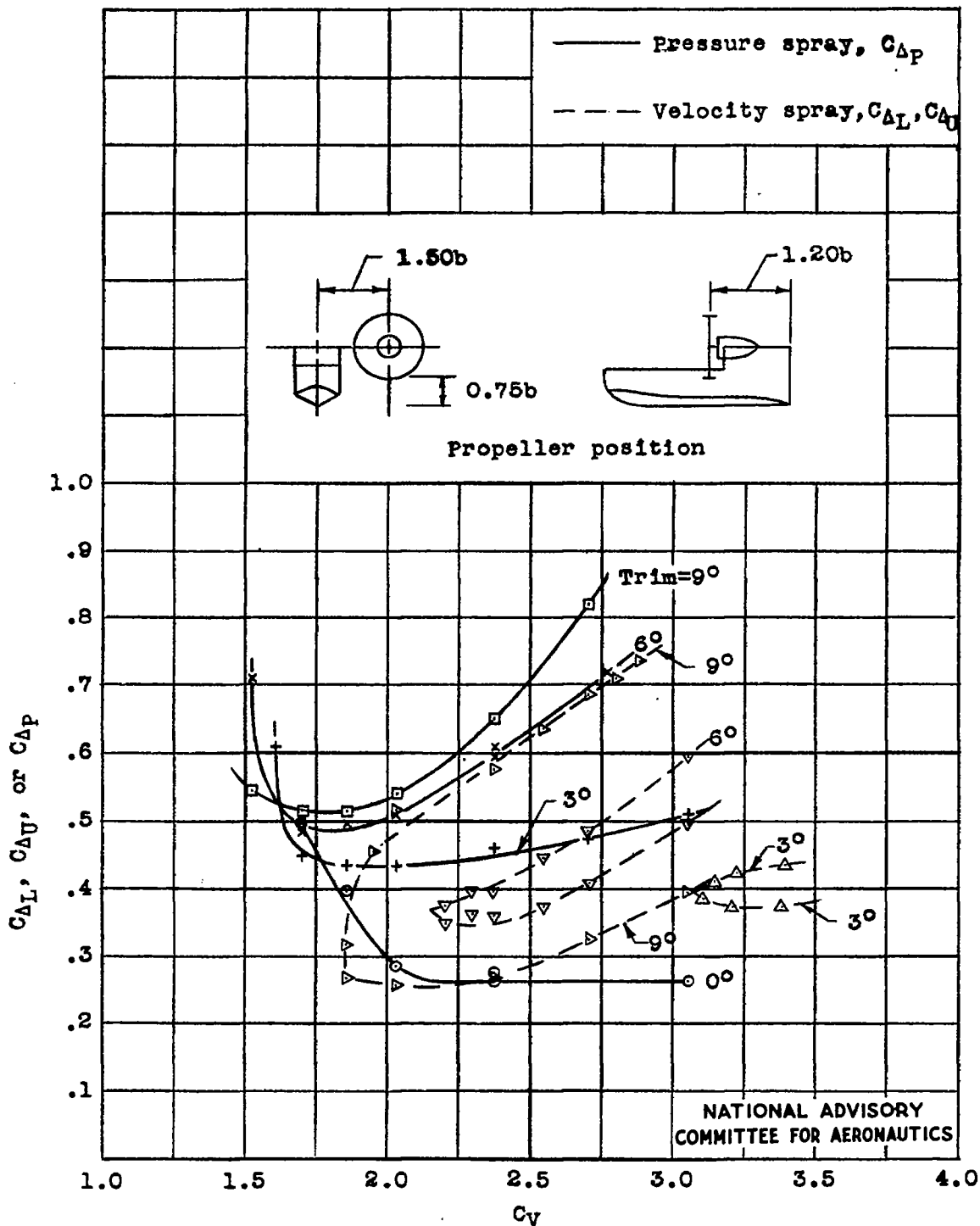

Figure 10.- Variation of critical load coefficient for spray with speed coefficient at various trims.  
 $x = 1.20b$ ;  $y = 1.50b$ ;  $z = 0.75b$ .

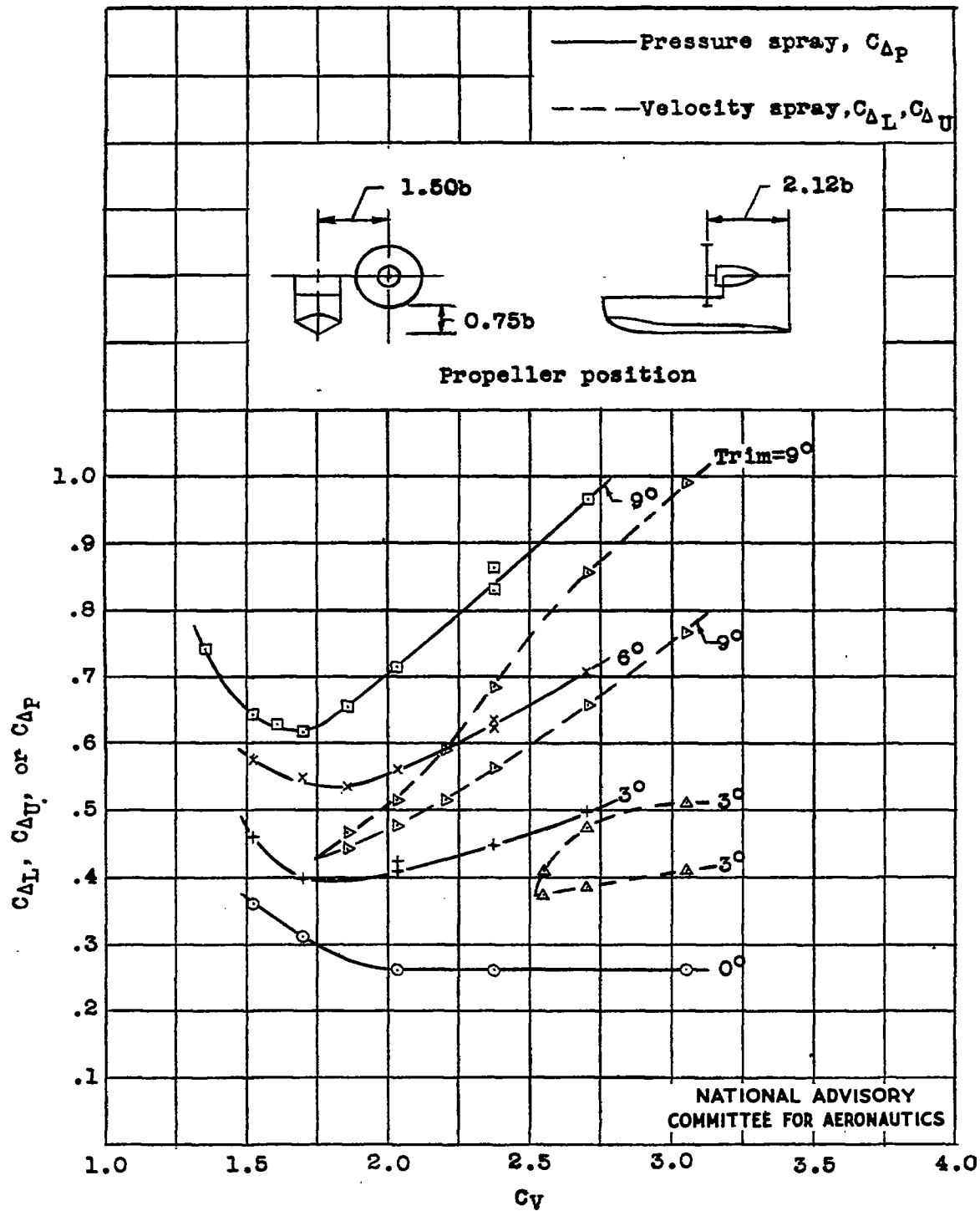

Figure 11.- Variation of critical load coefficient for spray load with speed coefficient at various trims.

$$x = 2.12b; y = 1.50b; z = 0.75b.$$

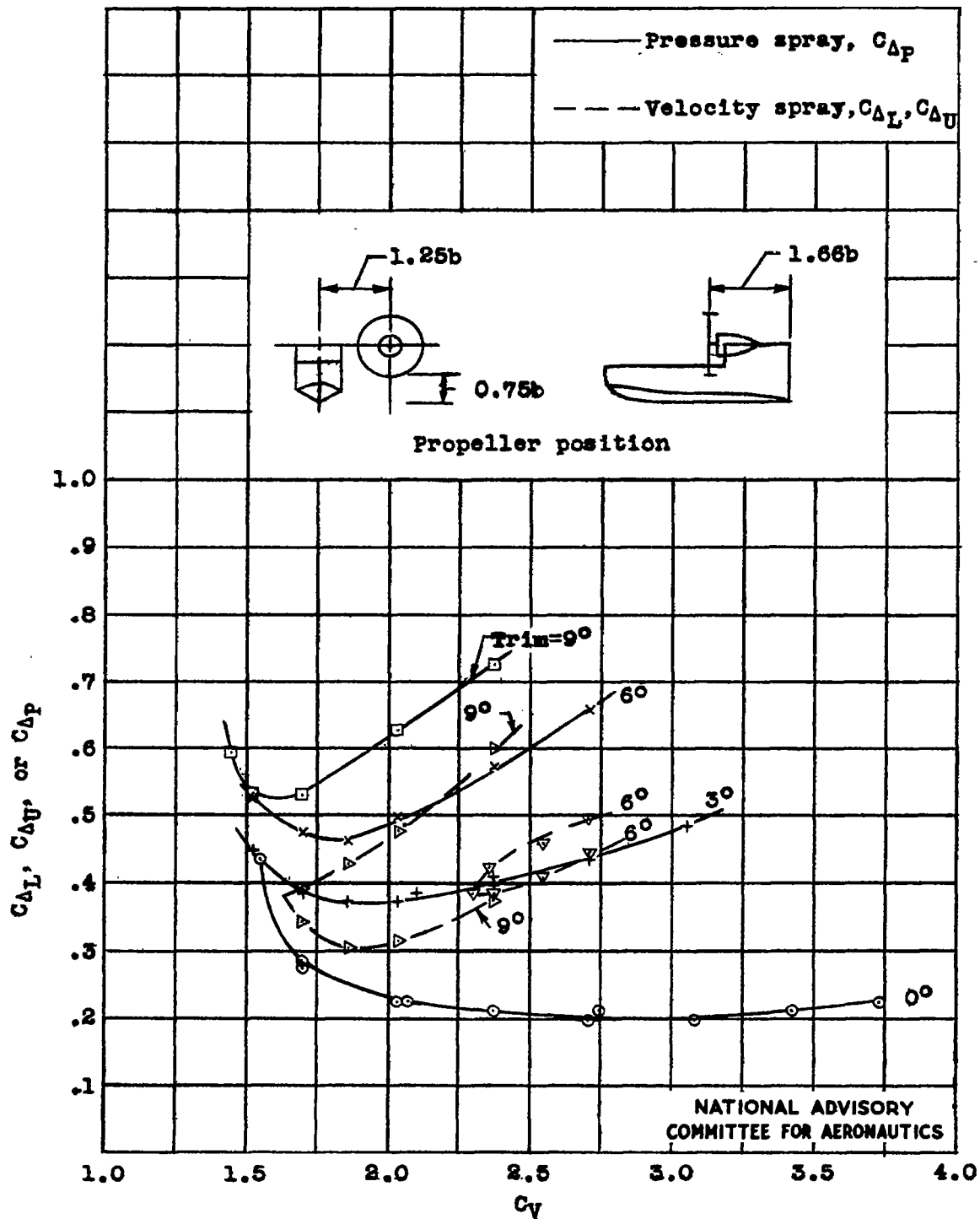

Figure 12.- Variation of critical load coefficient for spray with speed coefficient at various trims.  
 $x = 1.66b$ ;  $y = 1.25b$ ;  $z = 0.75b$ .

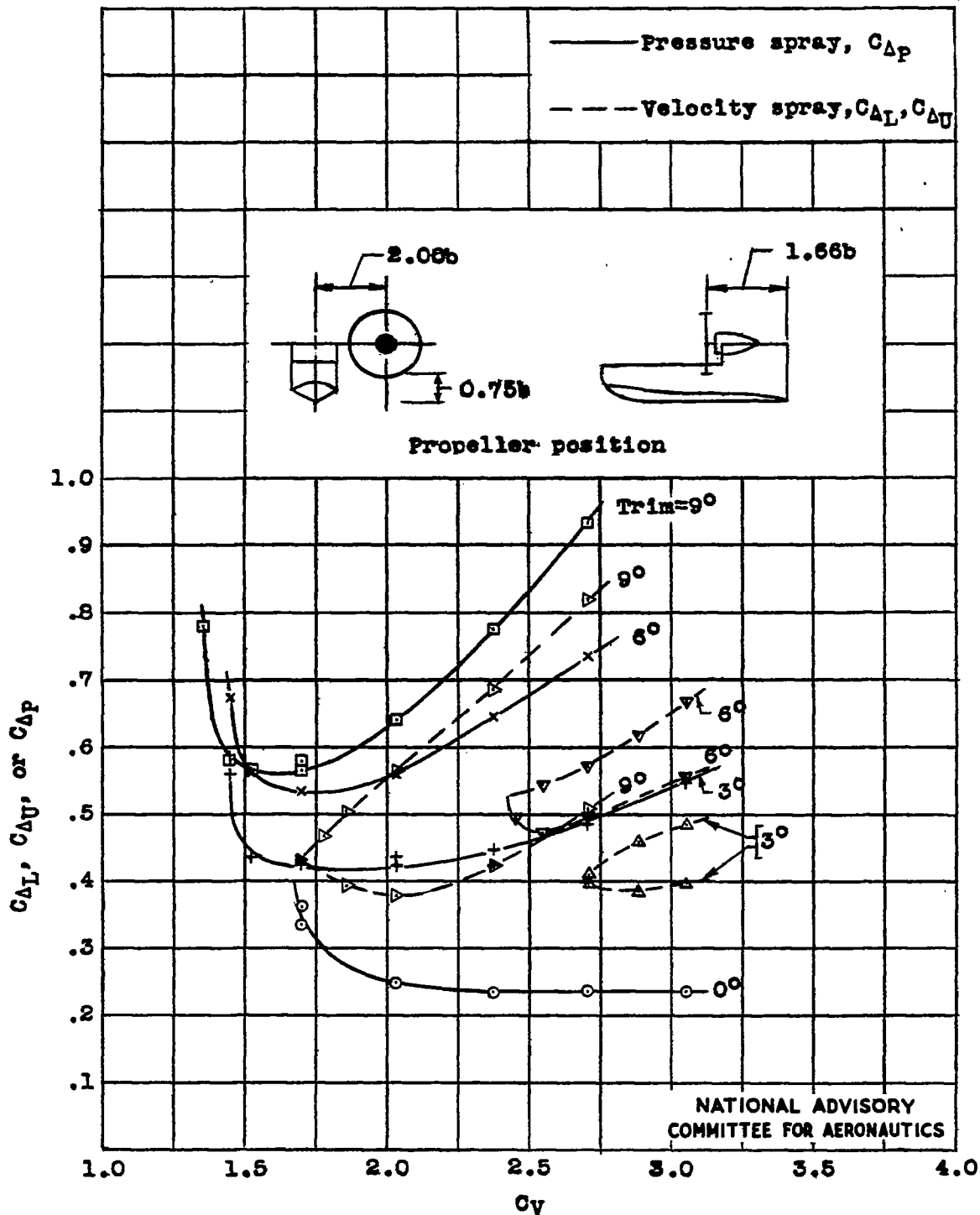

Figure 13.- Variation of critical load coefficient for spray with speed coefficient at various trims.  
 $x = 1.66b$ ;  $y = 2.00b$ ;  $z = 0.75b$ .

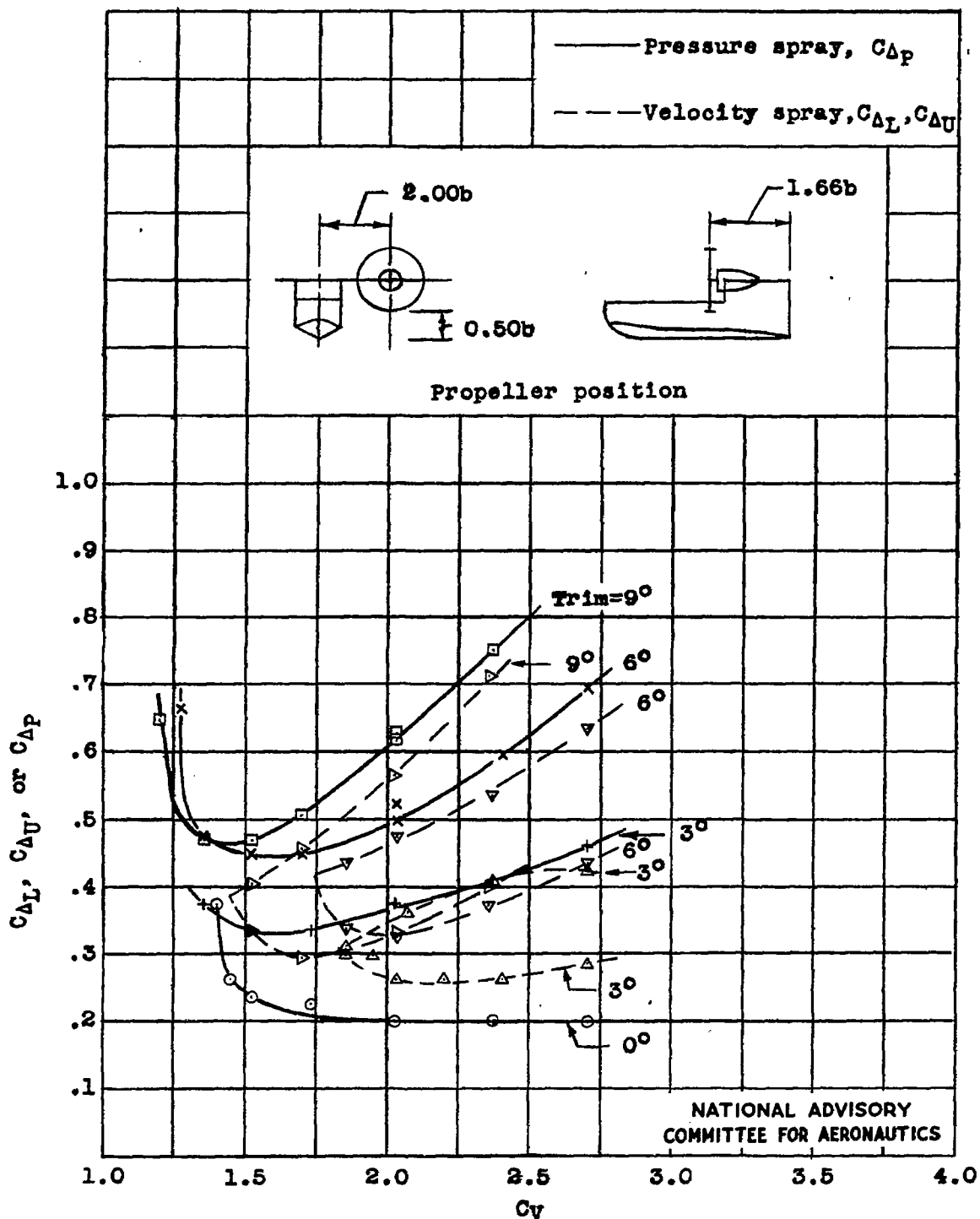

Figure 14.- Variation of critical load coefficient for spray with speed coefficient at various trims.

$$x = 1.66b; y = 2.00b; z = 0.50b.$$

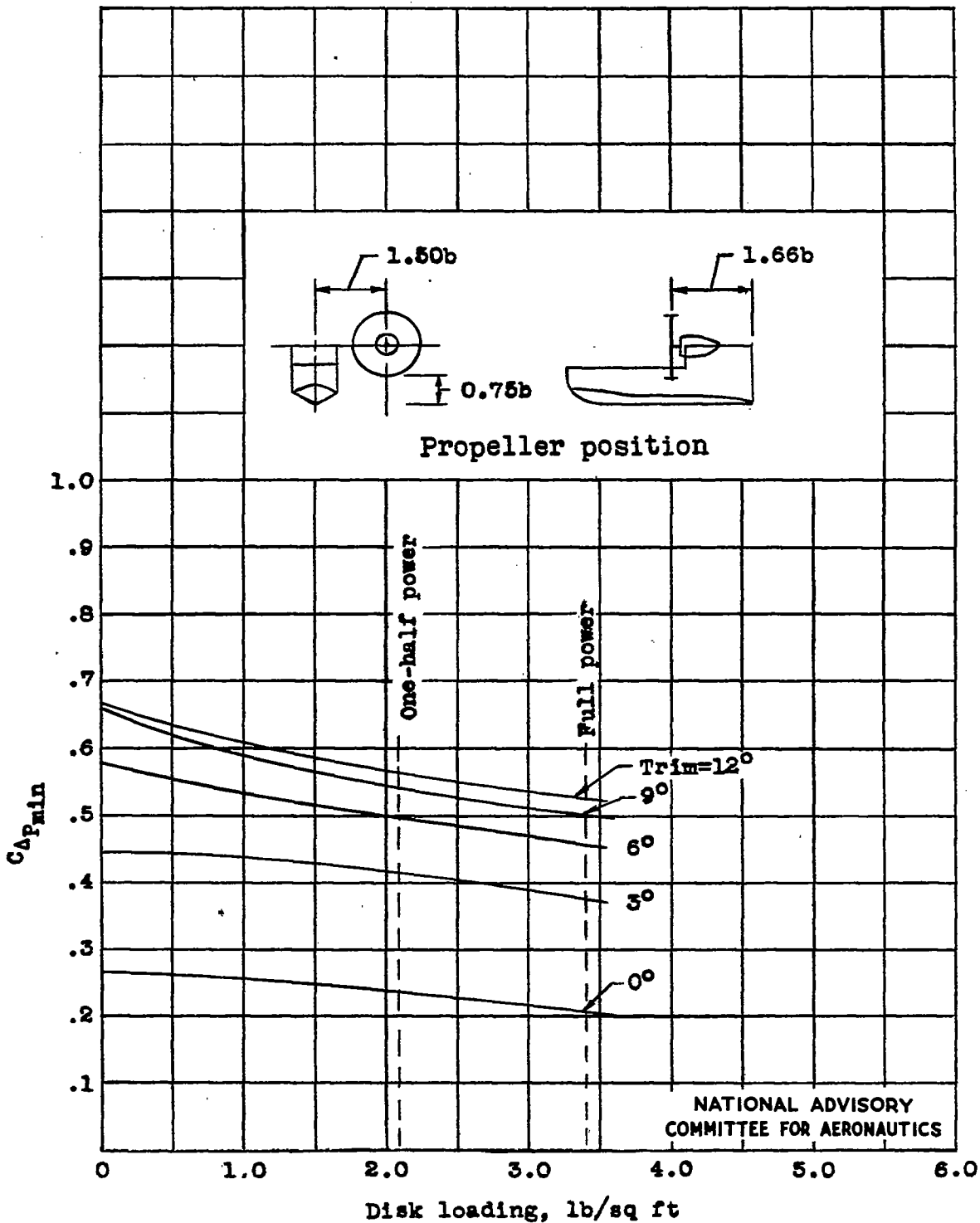

Figure 15.- Effect of disk loading on  $C_{p_{min}}$  at various trims.  
 $x = 1.66b$ ;  $y = 1.50b$ ;  $z = 0.75b$ .

NATIONAL ADVISORY  
 COMMITTEE FOR AERONAUTICS

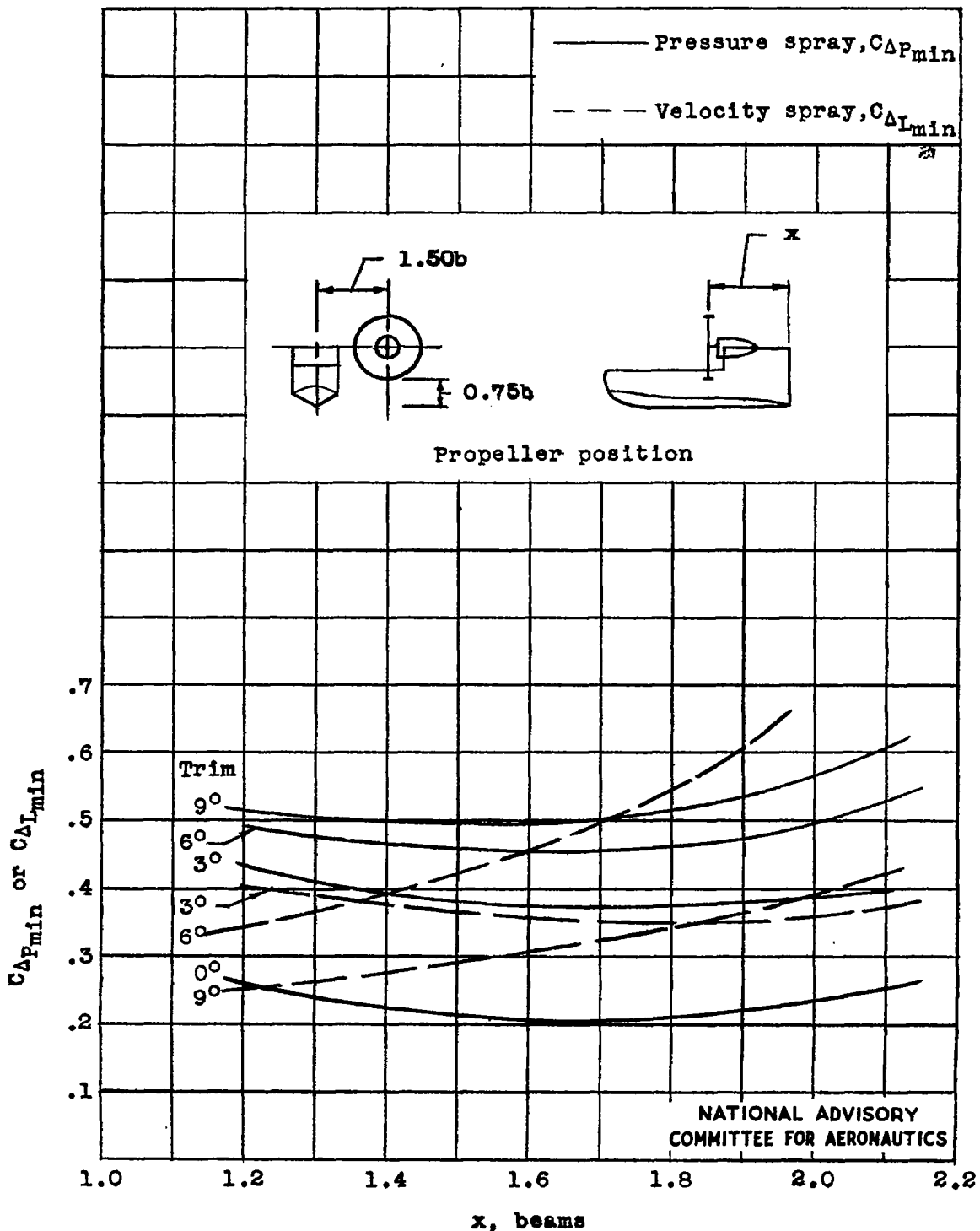

Figure 16.- Effect of longitudinal position of propellers on  $C_{AP_{min}}$  and  $C_{AL_{min}}$ .

NATIONAL ADVISORY  
COMMITTEE FOR AERONAUTICS

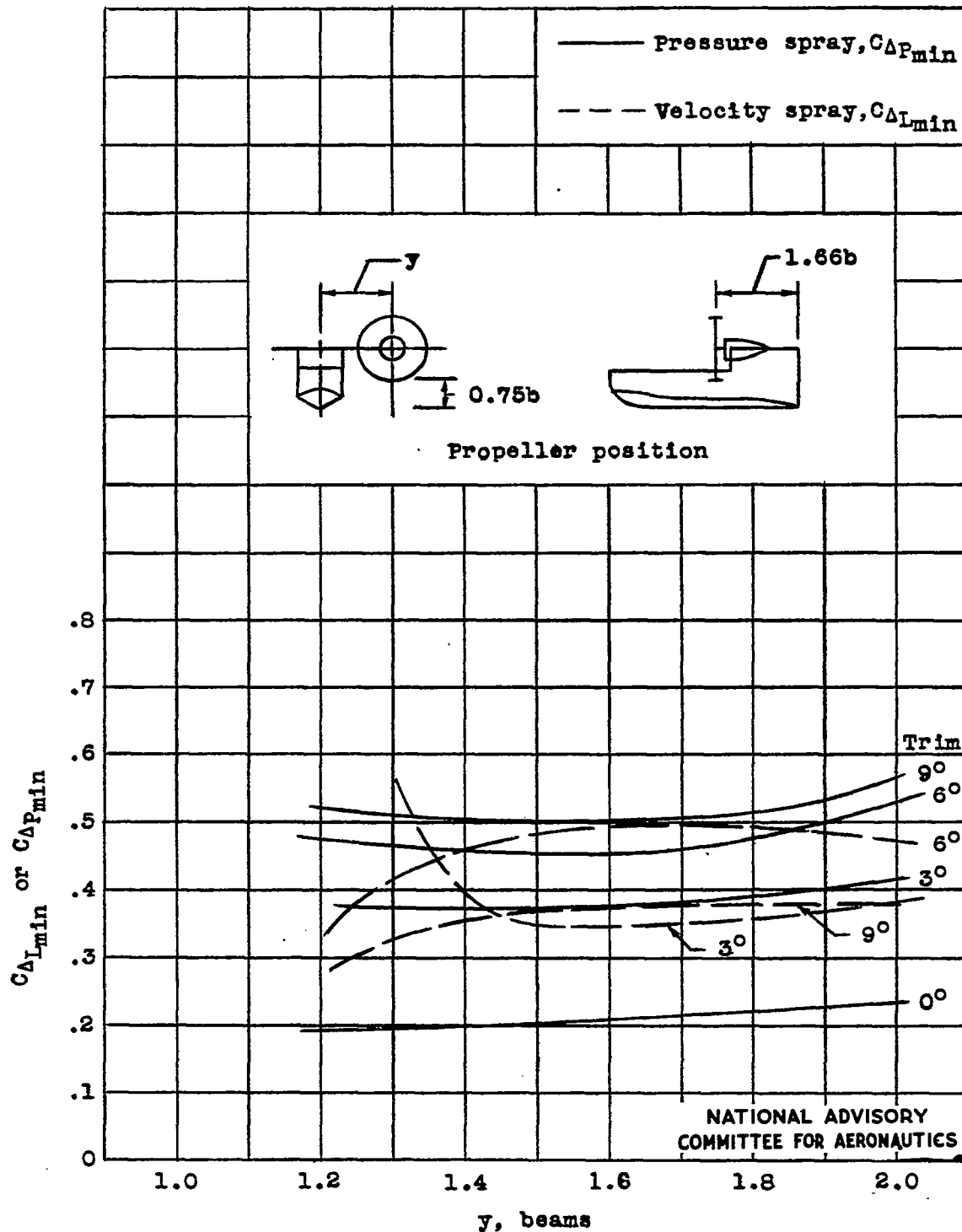

Figure 17.- Effect of lateral position of propellers on  $C_{\Delta P_{min}}$  and  $C_{\Delta L_{min}}$ .

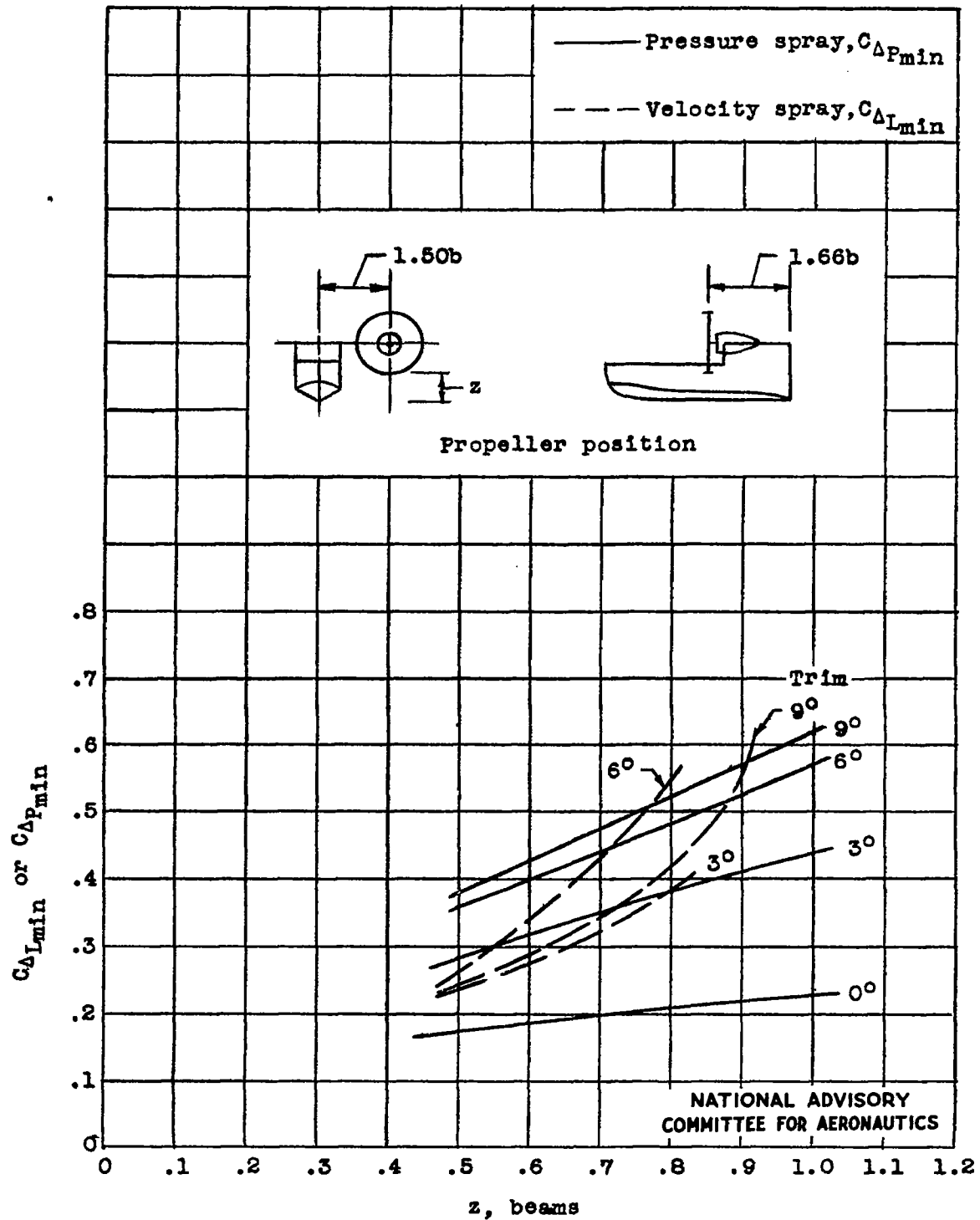

Figure 18.- Effect of vertical position of propellers on  $C_{Dpmin}$  and  $C_{Dlmin}$ .

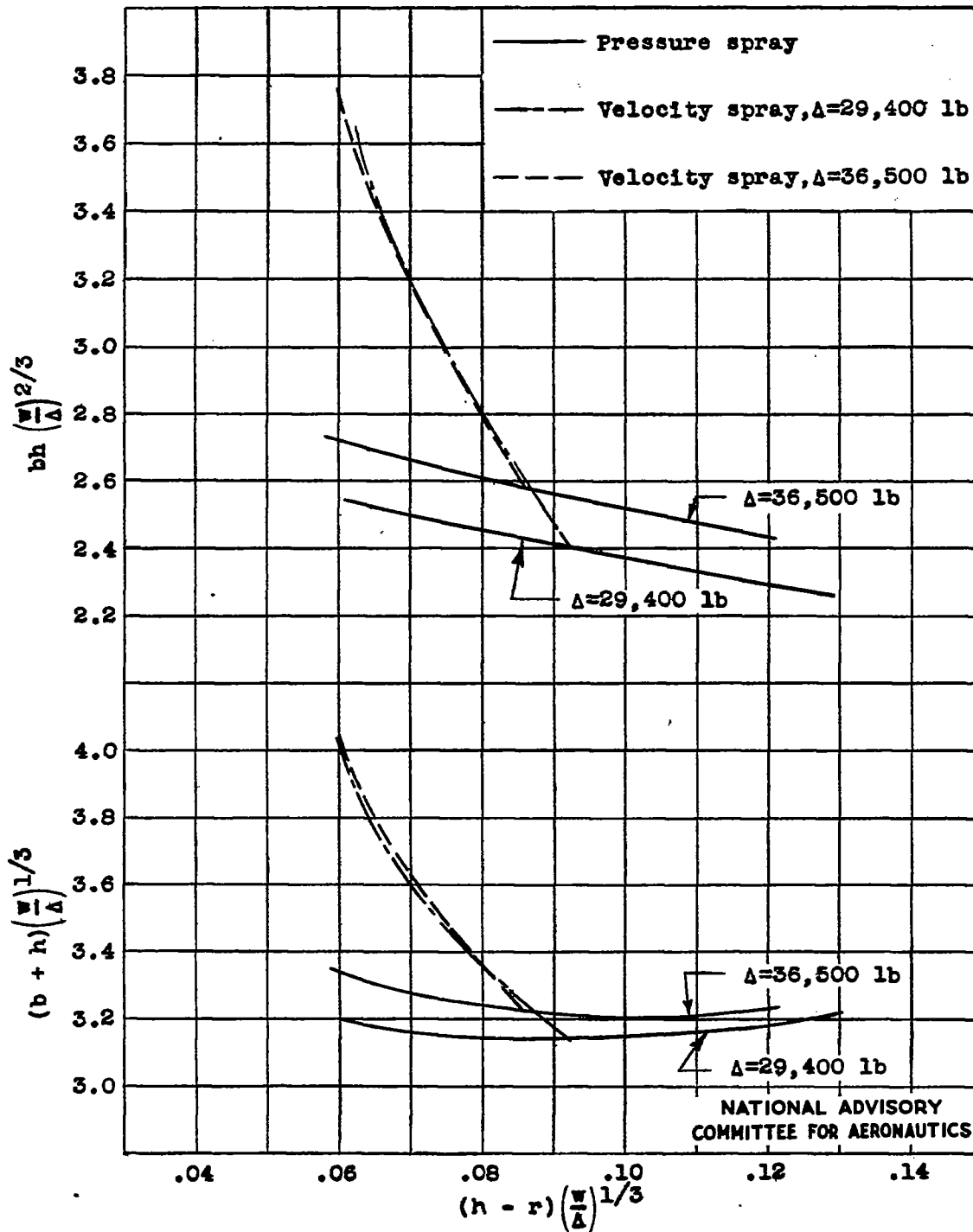

Figure 19.- Effect of vertical position of propellers on frontal area and periphery for a given design load with given spray characteristics.

**TITLE:** The Effects of Various Parameters on the Load at which Spray Enters the Propellers of a Flying Boat  
**AUTHOR(S):** Dawson, John R.; Walter, Robert C.  
**ORIGINATING AGENCY:** Langley Memorial Aeronautical Laboratory, Langley Field, Va.  
**PUBLISHED BY:** National Advisory Committee for Aeronautics, Washington, D. C.

ATI- 8187

REVISION

(None)

ORIG. AGENCY NO.

TN-1058

PUBLISHING AGENCY NO.

(Same)

DATE	DOC. CLASS.	COUNTRY	LANGUAGE	PAGES	ILLUSTRATIONS
May '48	Unclass.	U.S.	Eng.	37	photos, graphs

**ABSTRACT:**

The results of experiments made for investigating spray characteristics of flying-boat models are discussed. Minimum load at which spray strikes powered propellers was determined for range of speeds and trims. Pressure or velocity spray may limit gross load of flying boat, depending on configuration. Increasing power reduced load at which spray entered propellers. Increasing trim increased minimum load at which spray entered propellers, but corresponding load for velocity varied with trim. Normal lateral and longitudinal positions of propellers tended to be near position that gave the smallest value of minimum load at which spray struck propellers.

**DISTRIBUTION:** Request copies of this report only from Publishing Agency

**DIVISION:** Water-borne Aircraft (21)  
**SECTION:** Spray Control (3)

**SUBJECT HEADINGS:**

Flying boats - Spray characteristics (41760); Propellers - Interference effect of spray (75478.75)

**ATI SHEET NO.:** R-21-3-2