

MAY 21 1947

ARR No. 4B26

NATIONAL ADVISORY COMMITTEE FOR AERONAUTICS

WARTIME REPORT

ORIGINALLY ISSUED

February 1944 as
Advance Restricted Report 4B26

AN INVESTIGATION OF THE CHARACTERISTICS OF
ALCOHOL-DISTRIBUTION TUBES USED FOR ICE PROTECTION
ON AIRCRAFT WINDSHIELDS

By Richard Scherrer and Clair F. Young

Ames Aeronautical Laboratory
Moffett Field, California



NACA

WASHINGTON

N A C A LIBRARY
LANGLEY MEMORIAL AERONAUTICAL
LABORATORY
Langley Field, Va.

NACA WARTIME REPORTS are reprints of papers originally issued to provide rapid distribution of advance research results to an authorized group requiring them for the war effort. They were previously held under a security status but are now unclassified. Some of these reports were not technically edited. All have been reproduced without change in order to expedite general distribution.

NATIONAL ADVISORY COMMITTEE FOR AERONAUTICS

ADVANCE RESTRICTED REPORT

AN INVESTIGATION OF THE CHARACTERISTICS OF ALCOHOL

DISTRIBUTION TUBES USED FOR ICE PROTECTION

ON AIRCRAFT WINDSHIELDS

By Richard Scherrer and Clair F. Young

SUMMARY

An investigation has been conducted with alcohol used in conjunction with a windshield wiper as a means of affording protection against ice formation on the windshields of aircraft when operating in inclement weather. Flight tests conducted in a Lockheed 12A airplane under simulated icing conditions established the most economical flow rate of isopropyl alcohol to provide adequate ice prevention. The optimum location and size of the alcohol-distribution tube and orifices were determined for the specific installation investigated. A procedure by which economical and effective distribution can be obtained was developed and is presented.

INTRODUCTION

Alcohol has been utilized, for the past several years, to protect the windshields of aircraft from ice formations during flight in inclement weather. Owing to the opacity of alcohol streams it has been found desirable to use a windshield wiper in conjunction with the alcohol to maintain satisfactory visibility. Although this method of windshield protection has been used rather extensively, little or no information relative to an optimum arrangement of such a system has been reported.

The investigation reported herein has been conducted at the request of the Bureau of Aeronautics, Navy Department, to determine the most economical flow rate of isopropyl alcohol required to afford adequate ice protection, to determine the optimum size and location

of the orifices used to distribute the alcohol, and to formulate a procedure by which the aircraft designer could readily establish an economical and effective design.

EQUIPMENT

The test equipment used in this investigation was installed in the Lockheed 12A airplane shown in figure 1. A Marquette Metal Products Company windshield wiper, Model 3145E-1, sweeping a windshield area of 0.835 square feet, was installed on the pilot's windshield as shown in figure 2. The speed of the windshield-wiper blade was controlled by a 0.5-ohm, 15-ampere, variable resistor which was installed in the motor circuit to supplement the conventional two-speed control switch.

A schematic diagram of the alcohol-distribution system used is presented in figure 3. The solenoid pump, Marquette Metal Products Company Model 300, was used to pump the isopropyl alcohol from a tank, through 1/4-inch-~~outside-diameter~~ aluminum-alloy tubing, to the distribution tube located either on the windshield or on the blade of the windshield wiper. Control of the alcohol flow rate to the distribution tube was effected by a valve located in the supply tubing.

Icing conditions were simulated by spraying water into the air stream while flying at altitudes at which the ambient-air temperature was below the freezing point. The water spray was obtained by pumping water through two spray nozzles, located at the nose of the fuselage (fig. 1), which were adjusted to deliver a finely divided spray. The resultant water spray, at the altitudes at which the flight tests were conducted, produced icing at a rate comparable with a moderate freezing rain.

The tanks and pumps, which formed a part of the water-spray and alcohol-distribution systems, were installed in the forward baggage compartment of the airplane (fig. 4).

TESTS

Preliminary tests, consisting of tuft surveys in flight to determine the direction of air flow over the windshield, were conducted as the first step in the determination of the optimum location for the alcohol-distribution tube and the optimum size and arrangement of the orifices in the distribution tube. A typical example of a tuft survey as taken on the copilot's windshield is shown in figure 5. The tufts were mounted on the copilot's windshield so that the pilot's view would not be further obstructed. During further tests with the water spraying on the pilot's windshield, the flow pattern was noted to be similar to that shown in figure 5.

After determining the direction of air flow over the windshield in flight by means of the tuft surveys, the major portion of the investigation was conducted on the ground using a blower properly directed to simulate actual flight air-flow conditions. By this expedient, it was possible to test a great number of variations to the alcohol-distribution tube and its orifices more economically and expeditiously than would have been possible in flight. Tubes which exhibited satisfactory distribution characteristics in the ground tests were flight-tested at low altitude and, if the distribution characteristics were still satisfactory, further flight testing under simulated icing conditions was conducted. The tuft photograph and alcohol-distribution tests were made at an altitude of 5000 feet and an indicated airspeed of 150 miles per hour. At altitudes over 15,000 feet, the airplane was not capable of flying at an indicated airspeed of 150 miles per hour. As a result, the tests in simulated icing conditions at those altitudes were conducted at an indicated airspeed of 130 miles per hour. The final tests of the distribution tube located on the wiper blade were conducted at an altitude of 12,300 feet at which an indicated airspeed of 148 miles per hour was obtained.

In all flights under simulated icing conditions, the alcohol flow rate was adjusted until the minimum flow rate required to provide good visibility, was established. At this minimum flow rate, the position of the valve controlling the flow was noted and the actual flow rate was subsequently determined on the ground by

retrieving the alcohol as it was pumped through the distribution tube under the same conditions as established in flight. It is believed that the difference between the flow rate as measured on the ground and the actual flow rate in flight is negligible. During the progress of the investigation, it was found that better control of the windshield-wiper speed was necessary than was available with the original equipment. Therefore, the variable resistor was installed in the windshield-wiper motor circuit so that the wiper speed as well as the alcohol flow rate could be varied until the best results were obtained.

Three locations of the alcohol-distribution tube were investigated. These locations were diagonally along the center of the windshield, as shown in figure 6; vertically, as shown in figure 7; and on the blade of the windshield wiper, as shown in figure 8. In each instance, the location of the distribution tube was upstream from the wiped area. At each location of the distribution tube, several orifice sizes and arrangements were investigated.

ACCURACY

The measurement of the quantity of isopropyl alcohol required for ice prevention obtained in this investigation is subject to possible error due to the use of simulated icing conditions. The results also are of limited value due to the restricted velocity and air-temperature range at which the tests were conducted. Simulated icing tests are made in dry ambient air which usually has a humidity below saturation and, therefore, more evaporative cooling occurs. In this respect, tests in simulated icing conditions give conservative results.

The rate of icing produced on the testing region is made to conform to that of natural icing conditions, according to the experience of the test personnel, since the measurement of such factors has not yet been developed. Although the flight test personnel engaged in this investigation has had experience in icing conditions, this method is admittedly unsatisfactory since it is subject to error and because other investigators cannot duplicate the test conditions.

Irrespective of the inaccuracies which are involved in simulated icing tests, it is believed that the information on distribution presented herein is reliable and that more conclusive flow data probably cannot be obtained short of operational use of the equipment.

RESULTS AND DISCUSSION

The mechanical arrangement of the distribution tubes, the flight conditions under which the tests were conducted, the flow rate of isopropyl alcohol required for each test condition, and general comments relative to the operation and ice-protection characteristics of each arrangement tested are presented in table I.

Visibility, through the windshield with the aid of alcohol when the windshield wiper is in operation, depends upon the removal of the ice and also the optical qualities of the alcohol film. With visibility as the criterion, the results of the investigation indicated that, for the tests conducted, the optimum location for the alcohol-distribution tube was on the upstream side of the windshield-wiper blade, parallel to the face of the windshield and approximately 1/4 inch from the windshield (fig. 9). In this location, the most satisfactory operating conditions were obtained with a 1/8-inch-
outside-diameter distribution tube provided with six orifices, drill size number 80, spaced approximately 1 inch on centers. None of the number 80 drill-size orifices clogged during the tests, although under service conditions larger orifices may be required. A windshield-wiper speed of approximately 120 cycles per minute and an isopropyl-alcohol flow rate of 2.4 quarts per hour were found most suitable for this arrangement. An alcohol flow rate of 2.4 quarts per hour, or a unit flow rate of 2.9 quarts per hour, square foot was sufficient to afford adequate protection against ice formation; however, a flow rate of 4.9 quarts of alcohol per hour (or a unit flow rate of 5.9 qt/hr, sq ft) was required to remove ice which had been allowed to form prior to placing the equipment into operation. The area swept by the windshield-wiper blade was the only portion of the windshield surface which was consistently protected by the alcohol. The results of a flight in simulated icing conditions with the system described above in operation are shown in figure 10.

The most satisfactory fixed distribution tube tested, arrangement 6, was a vertically located 1/8-inch-outside-diameter tube with two 0.040-inch-outside-diameter copper tubes soldered into it. The 0.040-inch tubes extended in a horizontal position, parallel to the windshield, with the ends approximately 1 inch closer to the windshield-wiper blade than were the orifices on other vertical fixed-distribution tubes. The ends of the tubes were pinched together to give an alcohol flow rate comparable to two number 80 drill-size orifices with a similar alcohol control-valve setting. The 0.040-inch-outside-diameter tubes, although useful in the conduct of the tests, were found to be very fragile and, therefore, not suitable for service installations.

The speed of the windshield-wiper blade was found to have a marked effect upon the alcohol distribution and effectiveness of the system. At rapid blade speeds the alcohol was wiped from the windshield surface too quickly to protect the windshield effectively even at the greatest alcohol flow rates possible with the equipment.

Ice formations on a fixed-distribution tube were observed to alter the flow of alcohol across the windshield, indicating that flow patterns established in dry-air flights are not reliable.

It was noted during simulated icing flights that ice began to form on the windshield at an ambient-air temperature of 40° F. Consequently, a thermocouple was mounted on the wiper blade 1/2 inch from the windshield to determine the refrigeration effect due to evaporation of the alcohol-and-water mixture. Readings were taken during flight at 5000 feet altitude with the water-spray and alcohol systems in operation. At an ambient-air temperature of 60° F, a temperature drop of 45° F due to evaporative cooling was measured. The possibility of evaporation cooling the water-and-alcohol mixture in the air stream below the freezing point of the mixture should be further investigated. The research should be conducted in natural icing conditions to determine the true effect of alcohol and water evaporation. The refrigeration effect is expected to be less in natural icing conditions than that measured in simulated conditions.

With the possibility of low temperatures at the windshield, care should be taken to insure that the rubber

used for the windshield-wiper blade is capable of retaining its elasticity under such conditions.

The alcohol systems tested were capable of affording ice protection to the windshield, and similar systems could be installed on aircraft now in service with a minimum of alteration to the airplane; however, alcohol as a means of preventing ice on aircraft windshields is not as satisfactory as other systems, notably double-glazed air-heated panels. (See references 1 and 2.)

RECOMMENDED PROCEDURE AND DESIGN

The most satisfactory distribution tube of those investigated was mounted on the upstream side of the windshield-wiper blade; however, it is possible that fixed distribution tubes may be used to advantage on other windshields.

A design procedure to be followed for locating a fixed distribution tube is as follows:

1. Determine the direction of air flow over the windshield surface at the design airspeed and altitude by tuft surveys.
2. Install the windshield-wiper and alcohol systems, providing mountings for the distribution tube.
3. The orifices for any distribution tube should be located upstream from the center of the area to be protected as determined by the tuft directions.
4. The design of the distribution tube selected should be tested in flight to adjust the position of the orifices to give the optimum alcohol distribution.
5. The final design should be flight-tested in natural or simulated icing conditions.

Amos Aeronautical Laboratory,
National Advisory Committee for Aeronautics,
Moffett Field, Calif.

REFERENCES

1. McBrien, R. L.: An Aircraft Double Windshield - Its Development and Use. SAE Jour., (Trans.) vol. 51, no. 10, Oct. 1943, pp. 350-355.
2. Kushnick, Jerome L.: Thermodynamic Design of Double-Panel, Air-Heated Windshields for Ice Prevention. NACA RB No. 3F24, June 1943.

TABLE I.- CHARACTERISTICS OF ALCOHOL-DISTRIBUTION TUBES USED IN CONJUNCTION WITH A WINDSHIELD WIPER
TO PREVENT ICE FORMATION ON THE WINDSHIELD OF THE LOCKHEED 12A AIRPLANE

Test number	Distribution tube location	Tube size O.D. (in.)	Orifice size drill number (in.)	Number of orifices	Orifice location	Indicated air-speed (mph)	Pressure altitude (ft)	Ambient-air temp. (°F)	Isopropyl alcohol flow rate (qt/hr)	Isopropyl alcohol unit flow rate (qt/hr, sq ft)	Comments
1	Diagonal	1/4	70 0.0280	1	Center of tube	130	17,000	22	6.8	8.1	With the system in operation, ice was prevented from forming on the windshield; however, when ice was allowed to accumulate it could not be removed. The amount of alcohol required was considered excessive.
2	Diagonal	1/4	80 0.0135	2	2 in. apart center of tube	130	15,000	26	3.4	4.1	A thin film of ice remained on the windshield even at the maximum alcohol flow rate obtainable for this arrangement.
3	Diagonal	1/4	----- 0.008	3	2 in. apart center of tube	130	15,000	29	2.0	2.4	A thin film of ice remained on the windshield even at the maximum alcohol flow rate obtainable for this arrangement.
4	Vertical	1/4	----- 0.008	4	1 in. apart centered on windshield	---	-----	--	2.6	3.1	The air-flow pattern was disturbed due to the size of the distribution tube and the alcohol would not flow across the windshield. Simulated icing tests were not conducted.
5	Vertical	1/8	80 0.0135	2	3/4 in. apart top hole 3 in. from bottom of windshield	130	14,100	28	3.4	4.1	A slight improvement in visibility over arrangement 2 was noted; however, a thin film of ice remained on the windshield even at the maximum alcohol flow rate obtainable for this arrangement.
6	Vertical	1/8	0.040 tubes with ends pinched	2	1 in. apart top hole 3 1/2 in. from bottom of windshield	130	15,000	28	3.3	3.9	With the windshield wiper operating, a slight improvement over arrangement 5 was noted. With the windshield wiper inoperative, the alcohol cleared the ice from the windshield more satisfactorily than for arrangement 5, but a marked opacity of the alcohol stream was evidenced. This arrangement proved to be the most satisfactory fixed-tube arrangement investigated.
7	On the wiper blade	1/8	80 0.0135	2	2 in. apart centered on wiper blade	130	16,000	31	3.4	4.1	Two bands each approximately 3/4 inch wide, where the orifices discharged onto the windshield, remained clear of ice. The remainder of the wiped area was coated with a thin film of ice; however, visibility with this arrangement was superior to that obtained with all fixed-tube arrangements investigated.
8	On the wiper blade	1/8	----- 0.008	4	2 in. apart centered on wiper blade	130	16,300	31	2.6	3.1	The results obtained with this arrangement were similar but inferior to those obtained with arrangement 7. The alcohol tended to disperse in the air stream and one orifice clogged during the test.
9	On the wiper blade	1/8	3 by 0.002 slot	---	Centered on wiper blade	---	-----	--	---	---	The distribution of alcohol was unsatisfactory, since the pressure available was insufficient to force the alcohol to the windshield for this arrangement. Flight tests were not conducted.
10	On the wiper blade	1/8	80 0.0135	4	1 in. apart centered 1/2 in. above center of wiper	130	15,000	28	6.8	8.1	The distribution of alcohol was not improved over the distribution obtained with arrangement 7. The windshield-wiper control was added during these tests and slower wiper-blade speeds resulted in increased visibility.
11	On the wiper blade	1/8	80 0.0135	6	1 in. apart centered 1/2 in. below center of wiper	148	12,300	24	2.4 to 4.9	2.9 to 5.9	The wiped area was uniformly protected at the low alcohol flow rate; however, it was necessary to use the high alcohol flow rate to remove ice which had been permitted to accumulate. This arrangement was the most satisfactory of all arrangements tested. (See figs. 7, 9, and 10.)

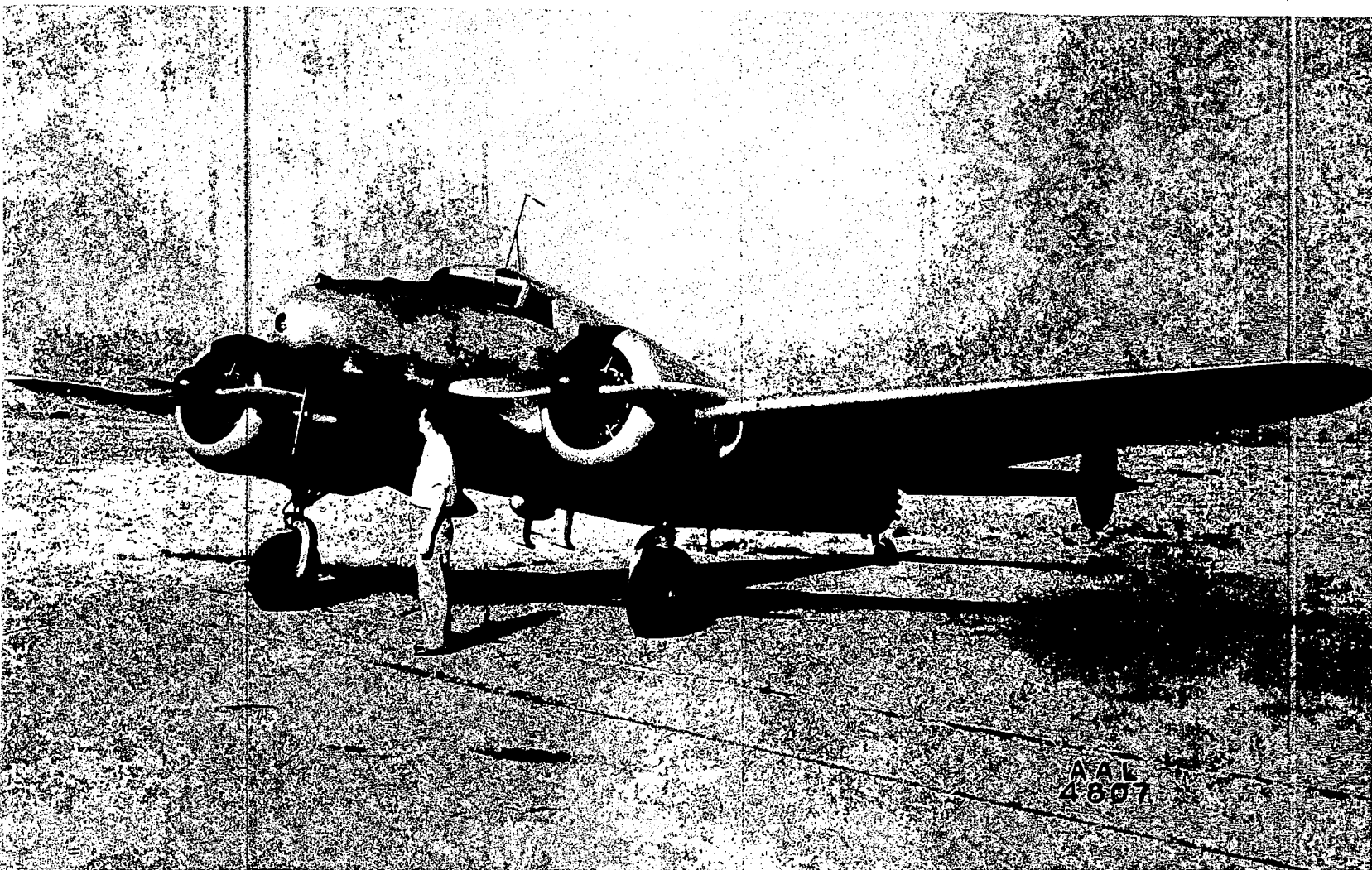

Figure 1.- The Lockheed 12A airplane, showing water spray nozzles on fuselage nose for forming ice in flight on the windshield.

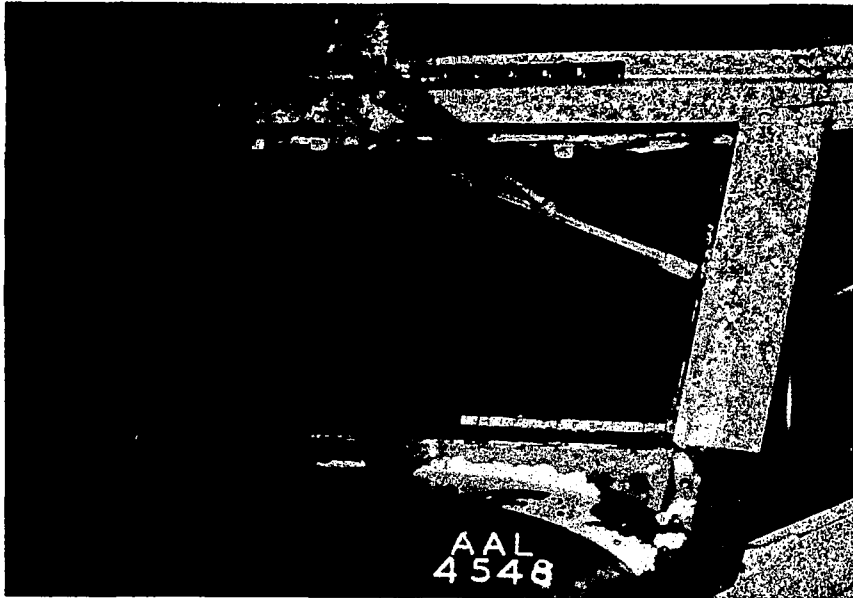

Figure 2.- Windshield wiper as installed on the pilot's windshield of the Lockheed 12A airplane.

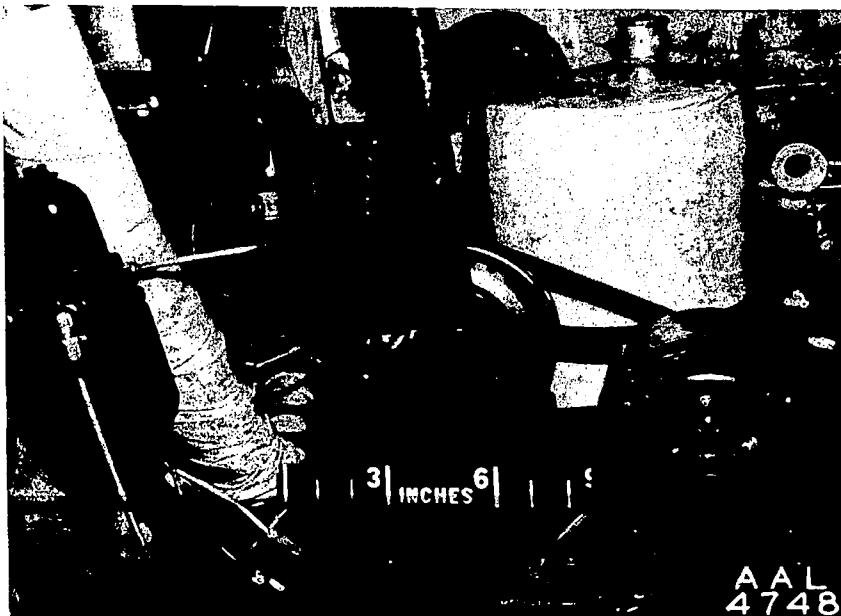

Figure 4.- Water-spray and windshield alcohol-supply-system equipment in the nose compartment of the Lockheed 12A airplane.

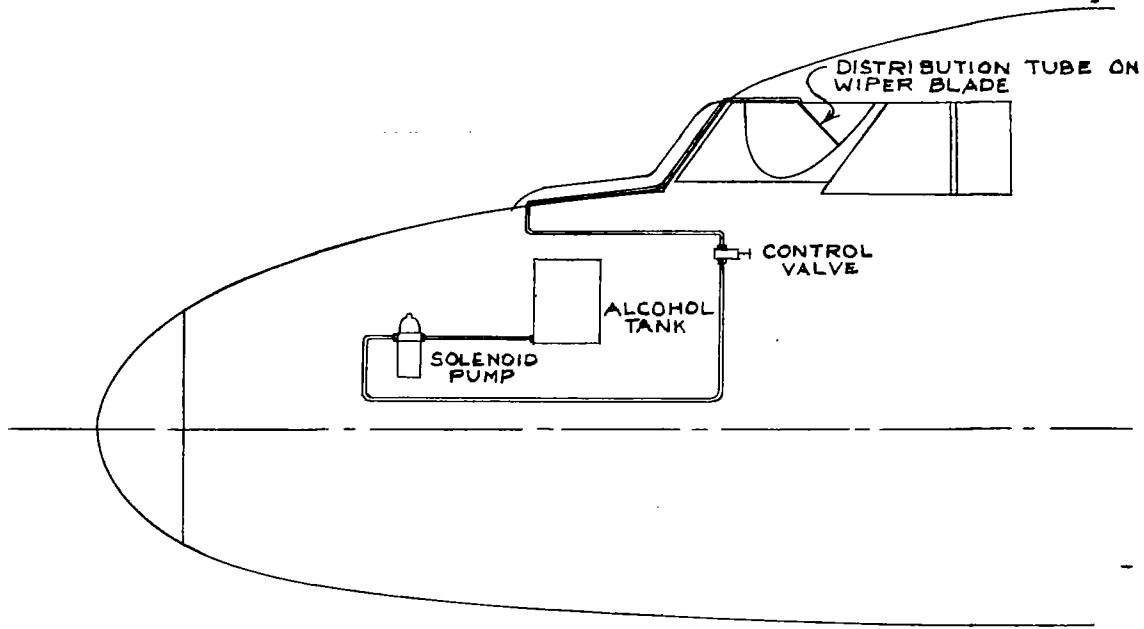

FIGURE 3.- ARRANGEMENT OF ALCOHOL ICE PREVENTION SYSTEM IN THE LOCKHEED 12A AIRPLANE

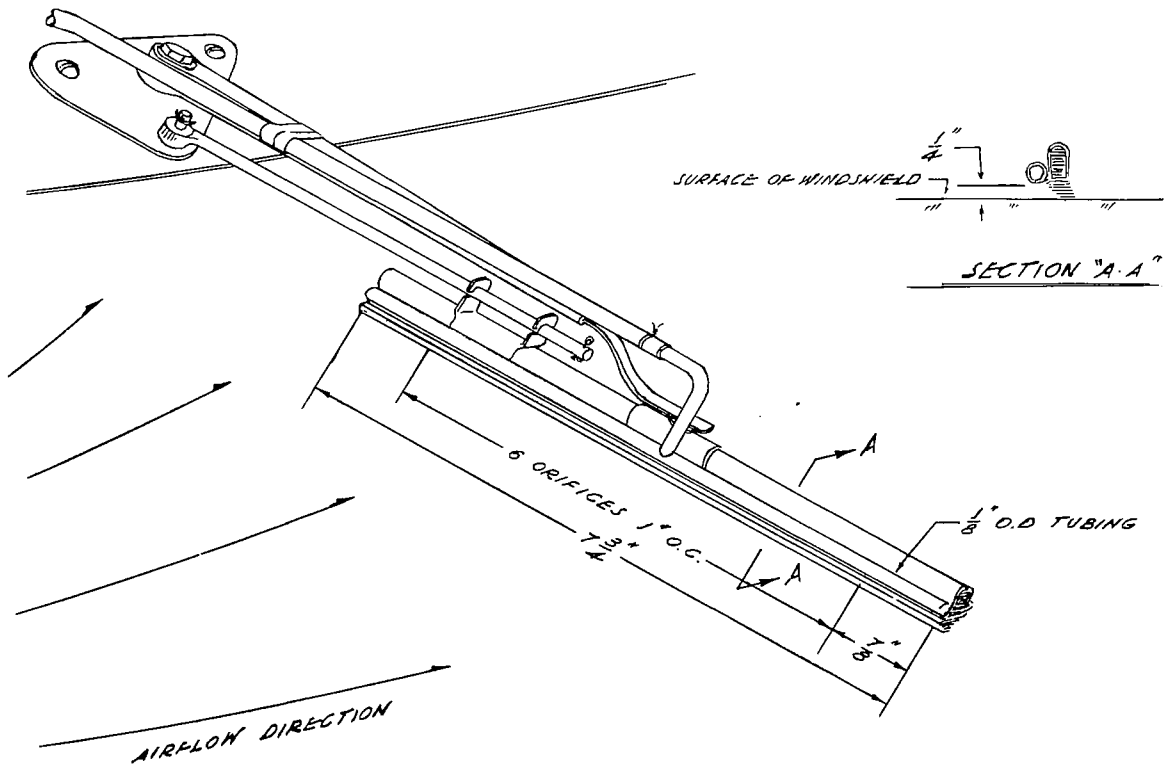

FIGURE 9. DISTRIBUTION TUBE WITH SIX ORIFICES, NO. 80 DRILL SIZE, MOUNTED ON THE WINDSHIELD WIPER BLADE OF THE LOCKHEED 12A AIRPLANE

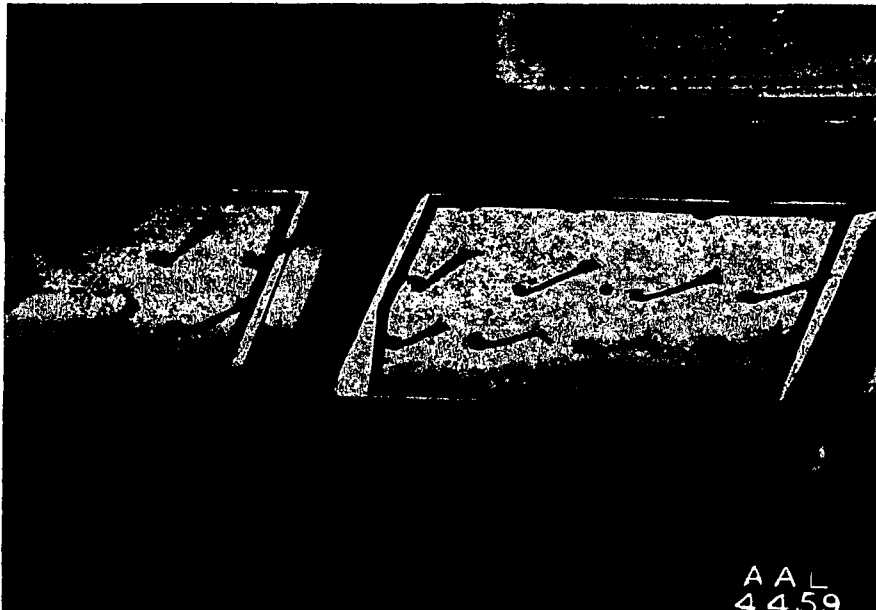

Figure 5.- Tufts indicating the direction of air flow over the windshield of the Lockheed 12A airplane in flight at 150 miles per hour.



Figure 10.- Windshield of the Lockheed 12A airplane with the distribution tube mounted on the windshield-wiper blade and the alcohol system operating in simulated icing condition.

Figure 6.-
Diagonal
location of
alcohol-
distribution
tube.

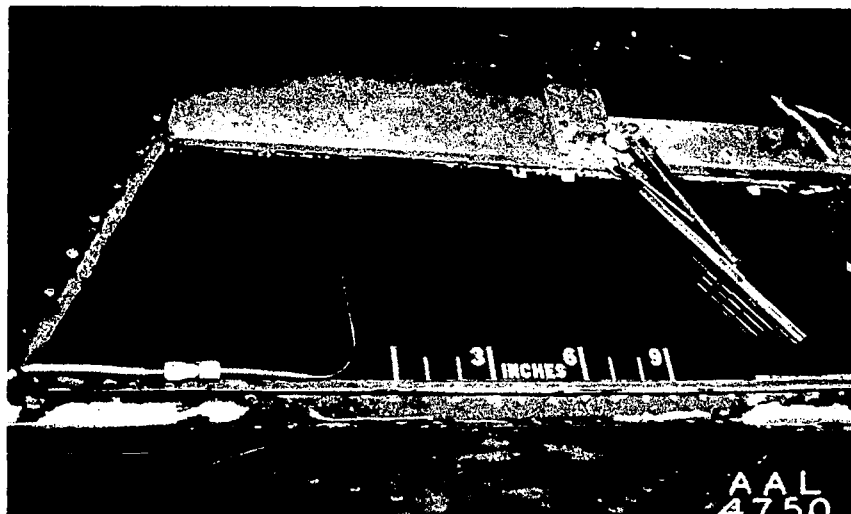
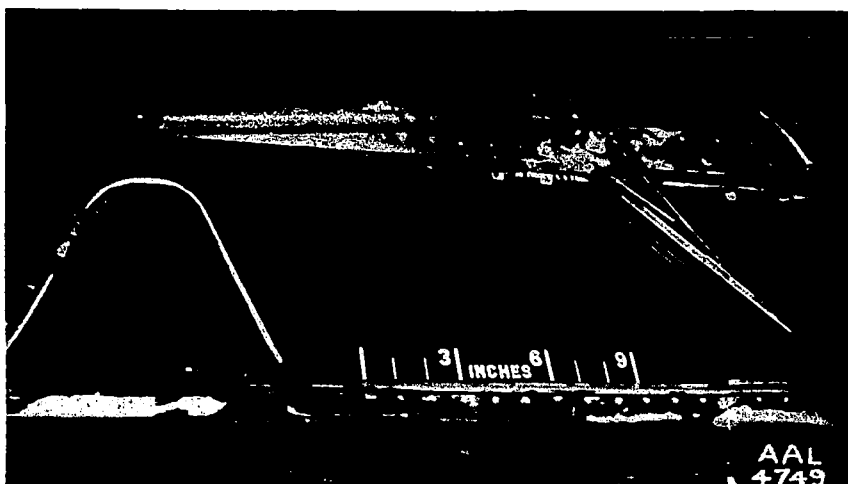
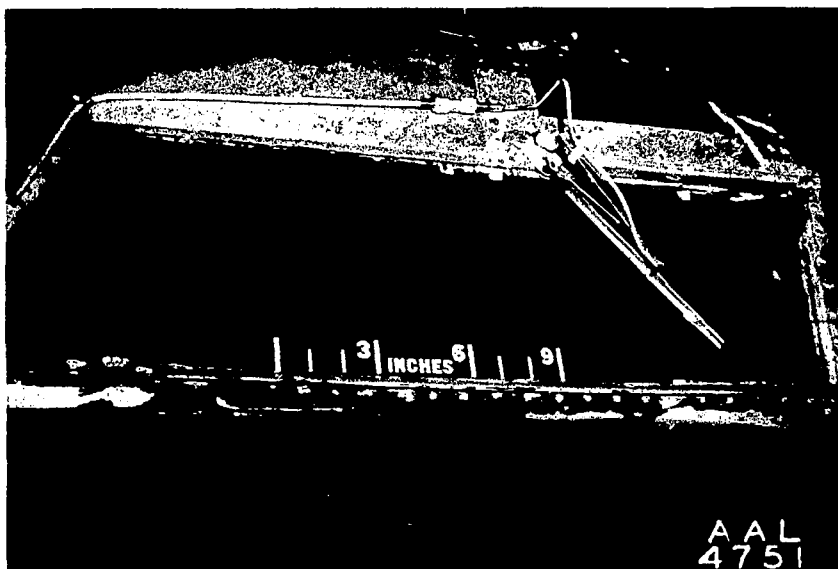

Figure 7.-
Vertical
location of
alcohol-
distribution
tube.

Figure 8.-
Alcohol-
distribution
tube mounted
on the wind-
shield-wiper
blade.



TITLE: Investigation of the Characteristics of Alcohol Distribution Tubes Used for
Ice Protection on Aircraft Windshields.

AUTHORS: Scherrer, Richard.; Young, Clair F.

ORIG. AGENCY: Ames Aeronautical Laboratory, Moffett Field, Calif.

PUBLISHED BY: National Advisory Committee for Aeronautics, Washington, D.

ATI- 8197

DIVISION

(None)

ORIG AGENCY NO

(None)

PUBLISHING NO

ARR-4B26

U

DATE	U.S. CLASS	COUNTRY	LANGUAGE	PAGE	ILLUSTRATIONS
Feb 54	Unclass	U.S.	English	14	photos, tables

ABSTRACT:

Tests made to determine use of alcohol in conjunction with a windshield wiper as means of affording protection against ice formation. Test conducted under simulated icing conditions demonstrated the most economical flow rate of isopropyl alcohol which provides adequate ice prevention. Optimum location and size of alcohol distribution tube and orifices determined. Procedure developed by which economical and effective distribution can be obtained.

DISTRIBUTION: SPECIAL. All requests for copies must be addressed to: Publishing Agency

DIVISION: Operating Problems (31)

SUBJECT HEADINGS:

SECTION: Icing (1)

De-icing, chemical (256v1.15)

ATI SHEET NO.:

Central Air Documents Office
Wright-Patterson Air Force Base, Dayton, Ohio

AIR TECHNICAL INDEX