



NATIONAL ADVISORY COMMITTEE FOR AERONAUTICS

TECHNICAL NOTE

No. 1418

20 OCT 1947

INVESTIGATION OF THE PRESSURE-LOSS CHARACTERISTICS
OF A TURBOJET INLET SCREEN

By John L. Lankford

Langley Memorial Aeronautical Laboratory
Langley Field, Va.



Washington

September 1947

NACA LIBRARY
LANGLEY MEMORIAL AERONAUTICAL
LABORATORY
Langley Field, Va.

NATIONAL ADVISORY COMMITTEE FOR AERONAUTICS

TECHNICAL NOTE NO. 1418

INVESTIGATION OF THE PRESSURE-LOSS CHARACTERISTICS
OF A TURBOJET INLET SCREEN

By John L. Lankford

SUMMARY

Results are presented of an investigation to determine the static-pressure losses and total-pressure distributions of a turbojet inlet screen. The screen which consists of 31 circular vanes supported by 12 radial struts, was tested in two configurations: one having the vane leading edges square and rough and the other having the vane leading edges rounded. The results of the investigation indicate that pressure losses increase rapidly with increasing weight flow, and slight radial and circumferential variations are present downstream of the screen. The rounding of the vane leading edges reduced static-pressure losses considerably and brought about slight improvements in total-pressure patterns.

INTRODUCTION

Turbojet inlet screens, which have been found useful in keeping foreign particles from entering compressor units, create disturbances in the inlet flow and thus affect adversely the performance of the turbojet propulsion unit. In order to design a very satisfactory inlet screen, it is necessary to evaluate the aerodynamic properties of the screen and the effect of the screen on the inlet flow. An investigation has consequently been made at the Langley induction aerodynamics laboratory to obtain the static-pressure losses across an inlet screen and the total-pressure distributions upstream and downstream of the screen. The screen tested was designed to prevent particles of 3/16-inch diameter or greater from entering a turbojet compressor. The investigation was conducted for the range of air flow through which the unit is designed to operate. Tests were made of two screen configurations: one with the vane leading edges square and rough and the other with the vane leading edges rounded.

SYMBOLS

H	total pressure, pounds per square foot
p	static pressure, pounds per square foot
p_B	measured barometric pressure
Δp	static pressure drop through screen, pounds per square foot
q	dynamic pressure upstream of screen, pounds per square foot
W	air flow, pounds per second
ρ	density of air upstream of screen, slugs per cubic foot
ρ_0	standard sea-level density, 0.002378 slug per cubic foot
σ	density ratio (ρ/ρ_0)
M	Mach number
T	temperature, °F absolute

Subscripts:

i	incompressible flow
1	conditions at station 1
2	conditions at station 2
3	conditions at station 3
4	conditions at station 4

Survey circumferential positions measured clockwise from top center of ducting looking downstream are identified by following subscripts:

a	survey at circumferential position of 0°
b	survey at circumferential position of 180°
c	survey at circumferential position of 90°
d	survey at circumferential position of 270°

DESCRIPTION OF APPARATUS

Turbojet Inlet Screen

The turbojet inlet screen, which is shown in figure 1, is an all metal screen designed for installation in the annular turbojet intake opening. The screen is constructed of 31 circular vanes roughly thirty-thousandths of an inch in thickness and about five-sixteenths of an inch in depth in the direction of flow. These vanes are supported between boundary strips by 12 radial struts. The struts are V-shaped in the plane of flow, giving the assembled screen a staggered or double-conical form with the vane at the apex of the cone upstream and forming a circle which bisects the annular space. Details of the screen construction are shown in figure 2. The screen as received with the leading edges of the vanes square and rough is designated configuration I. The leading edges of the vanes were rounded by hand after the results were obtained from the investigation of configuration I and, after the leading edges were rounded, the screen was designated configuration II.

Because some screen vanes are easily bent in shipping and handling, slight variations in downstream flow patterns may exist,

Screen Assembly and Other Apparatus

The screen was mounted in circular ducting of 21-inch internal diameter. The outer circumference of the screen was held by a wooden adapter ring and the inner screen boundary contained a wooden mock-up of a jet-unit starter-motor housing. The housing and the duct wall formed an annular measuring section which extended as a straight annulus through all measuring stations. Downstream of the last station a tapered afterbody expanded the annulus to duct area again. A photograph of the screen, motor housing, afterbody, and adapter ring assembly is shown in figure 1, and a photograph of the duct exterior is shown in figure 3. Power was supplied by a centrifugal blower to induce air from the test room through large bell inlets into cylindrical ducting. The ducting carried the air through the measuring section annulus having an area of 2.123 square feet and finally diffused it for entrance into the blower inlet. A diagram of the location and details of the measuring stations is given in figure 4.

Instrumentation

All pressures were indicated on a multiple-tube vertical manometer board connected to pressure tubes in the measuring section.

Provisions were made for pressure surveys at all stations in the measuring annulus. A total-pressure tube was located exactly in the center of the motor-housing nose. Static-pressure orifices and survey openings were located as shown in the cross-sections of the duct in figure 5. A shielded thermocouple installed at station 1 gave stagnation temperature readings.

Preliminary pressure surveys indicated uniform static-pressure distributions across the annulus both upstream and downstream of the screen. As a result of this information static orifices were used for static-pressure determinations in the actual investigations. Total-pressure distributions downstream of the screen were not very uniform, however, and surveys were used for total-pressure determinations in preference to fixed multiple-tube rakes. A photograph of one of the micrometer survey tubes is shown in figure 6. The micrometer feed on this survey tube permits positioning of the tube within one-thousandth of an inch along the survey radius.

METHODS OF PERFORMING TESTS

Flow Calibration

The approach section was calibrated as a nozzle for flow measurements by use of average readings of the wall static pressures at station 3 and the total-pressure readings of the reference tube at station 2. (See fig. 4.) A calibration curve is shown for this nozzle in figure 7. For convenience, a curve of Mach numbers at station 3 plotted against corrected weight flow is also given in figure 7.

Total-Pressure Surveys

Total-pressure surveys were made at stations 3 and 4. Surveys at station 4 were made along four radii spaced 90° circumferentially. The top of the ducting was taken as 0° and angles were measured clockwise looking downstream. Surveys were not made directly downstream of screen struts; Attempts were made to make all survey radii bisect the angle between screen struts as closely as possible.

Total-pressure surveys at station 3 indicated uniform pressure distribution upstream of the screen. Surveys at station 4 were made along two radii simultaneously. The tubes were then rotated to positions 90° removed from the first ones and the surveys were run in the new positions. As a result of this arrangement slightly different air flows and barometric pressures were occasionally

encountered at each set of positions since surveys required appreciable time. The barometric pressure and weight flow have been shown or listed for each survey profile. On the manometer board all surveys were referenced to the pressure from the tube in the nose of the motor housing. Pressure readings were taken relative to the nose pressure as a datum. Comparison of the reference-tube readings with the readings of the manometer tubes vented to the atmosphere showed them to be equal.

Static-Pressure Losses

Pressure losses were found by measuring the static-pressure changes across the screen. Pressures were taken from individual tubes leading to static orifices of stations 3, 4, and 5. Differences were found by comparing individual tube readings with the reference tube readings and with each other.

Calculations on pressure losses in smooth ducting indicate that the magnitude of the pressure losses caused by the duct between stations 3 and 4 is smaller than the accuracy of measurements in this investigation. This result is substantiated by the fact that no measurable loss is indicated between stations 4 and 5, which are located in ducting similar to that between stations 3 and 4. It is reasonable to assume, therefore, that all pressure losses measured are chargeable to the screen.

Configuration II was tested for static-pressure losses in the same manner as configuration I. Total-pressure surveys were also taken at the 90° position for comparison with those of configuration I.

The screen was tested for about 30 hours at flows above 70 pounds per second; for about 30 hours at flows of approximately 60 pounds per second; and for about 20 hours at flows of approximately 30 pounds per second without structural failure.

RESULTS AND DISCUSSION

Static-Pressure-Loss Coefficient

The relation of static-pressure-loss coefficient $\Delta p/q_1$ to weight flow W is shown for both configurations in figure 8. This coefficient was chosen in preference to the one based on loss of total pressure because of the greater convenience and accuracy with which it could be determined. This usage is conservative in design work because the static-pressure-drop coefficient is always equal to

or larger than the total-pressure-drop coefficient. The difference in the coefficient will be greatest at maximum air flows and has been found by calculation to be of the order of 20 percent in tests of configuration II at an air flow of 70 pounds per second.

The coefficient $\Delta p/q_1$ for configuration I is fairly constant at a value of 0.15 up to weight flows of 33 pounds per second. For weight-flow rates above this value the coefficient rises until at a flow of 60 pounds per second a coefficient of 0.183 is indicated. The maximum value for configuration I in this investigation was 0.325 at a flow of 82.5 pounds per second. The results for configuration II indicate that rounding the leading edges of the screen vanes reduced the pressure-loss coefficients for all flows. For the rounded-vane configuration a constant value of 0.105 was indicated for a flow up to about 45 pounds per second; the break of the curve for configuration II occurs at a higher value of weight flow than the break of the curve for configuration I. For configuration II at an air flow of 60 pounds per second the static-pressure-loss coefficient is 0.123 and reaches a maximum of 0.325 for this investigation at an air flow of 85.5 pounds per second. These results suggest that careful rounding and smoothing of all vanes as well as of the leading edges of struts before assembly and removal of all irregularities after assembly should reduce the losses even more.

Corrected Static-Pressure Loss

Absolute static-pressure losses corrected to standard conditions are shown in figure 9. The effect of rounding the vanes has been to decrease the losses as is shown by the curves in the figure. At a weight flow of 60 pounds per second, which is approximately design flow, configuration I shows a loss of 30 pounds per square foot compared with a loss of 20 pounds per square foot for configuration II. In short, at about design flow, rounding the vane leading edges has reduced losses by one-third. The curves rise sharply as air flows are increased until configuration I shows a loss of 95 pounds per square foot at a flow of 82 pounds per second and configuration II shows a loss of 106 pounds per square foot at a flow of 85.5 pounds per second.

Total-Pressure Distributions

Figure 10 shows the total-pressure distributions upstream of the screen at a weight flow of 28.24 pounds per second. Figures 11 and 12 show the upstream distributions at flows of 56.81 and 82.15 pounds per second, respectively. These patterns are very uniform and consistent over the range of proposed air flows. Only

at a flow of 82.15 pounds per second, which is above design flow, does any loss in total pressure become apparent. At 82.15 pounds per second the loss is only about 0.1 percent of the total pressure available. The barometric pressure is shown on each sheet.

The total-pressure distributions downstream of the screen are shown in figures 13 and 14. Distributions are shown for four circumferential positions for configuration I and for one circumferential position for configuration II. Weight flows and barometric pressure lines are indicated on each graph. Both radial and circumferential variations are present. Circumferential variations seemed greatest in an annular band slightly smaller in diameter than the center of the annular space between the motor housing and the duct wall. The maximum circumferential variation at design conditions is shown in figures 13(c) and 13(d) at approximately 60 pounds per second air flow to be approximately 1.35 percent of the total available pressure. Maximum radial variation at a flow of 60 pounds per second is approximately 1.5 percent of the total upstream pressure. These figures are for configuration I. In general, the variations increase in magnitude with increasing air flow.

Configuration II for the air flows and positions tested showed the same general patterns modified slightly by the rounded vanes. Figure 14 shows the total-pressure patterns at the 90° position for two air flows for configuration II.

CONCLUSIONS

An investigation made to determine the static-pressure losses and the total-pressure characteristics of a turbojet inlet screen indicates that, except at very low flow rates, static-pressure losses increase and total-pressure variations become more pronounced with increasing weight flow. Smoothing and rounding the leading edges of the screen vanes caused marked decreases in static-pressure loss coefficients and slightly improved total-pressure patterns.

Langley Memorial Aeronautical Laboratory
National Advisory Committee for Aeronautics
Langley Field, Va., June 24, 1947

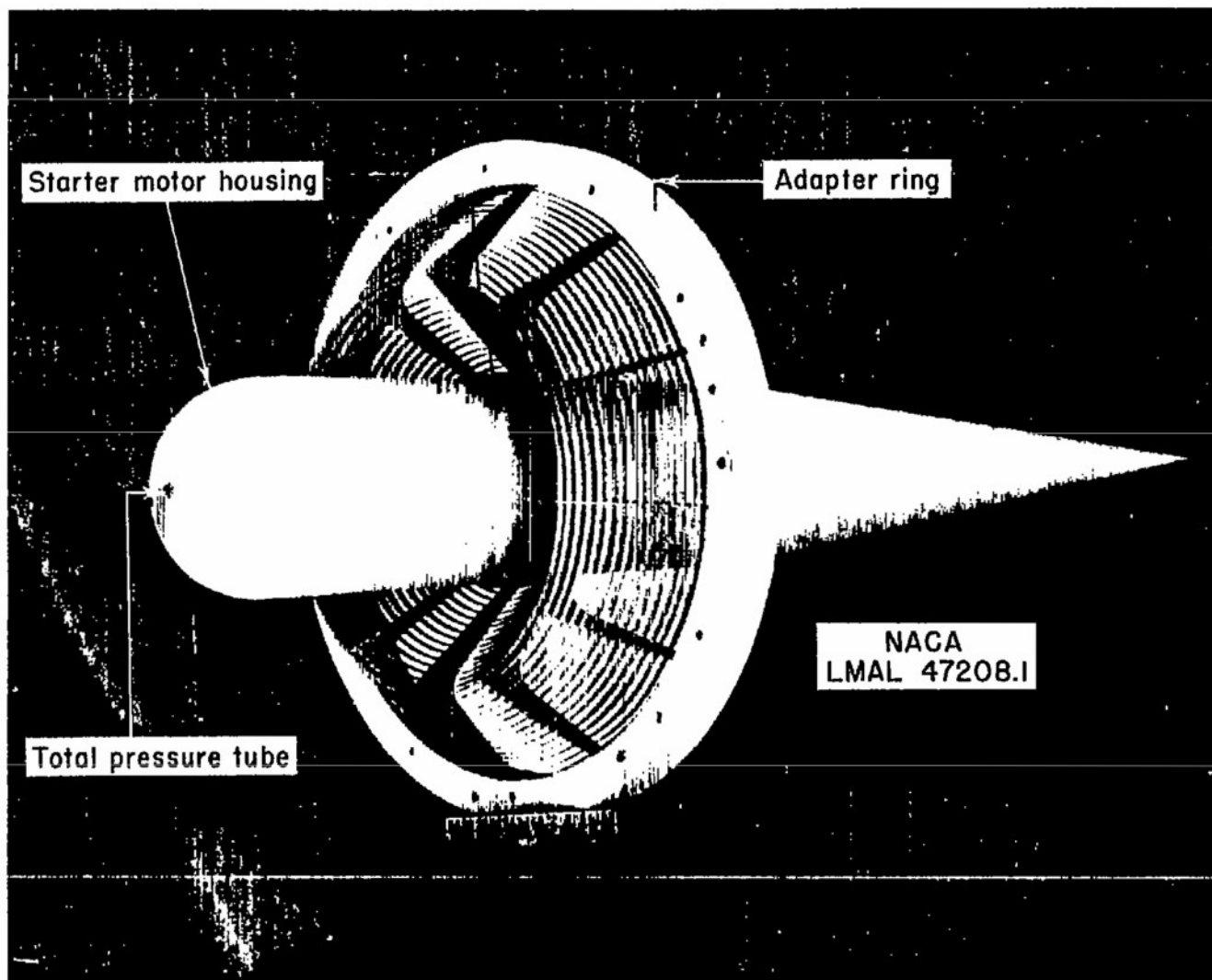
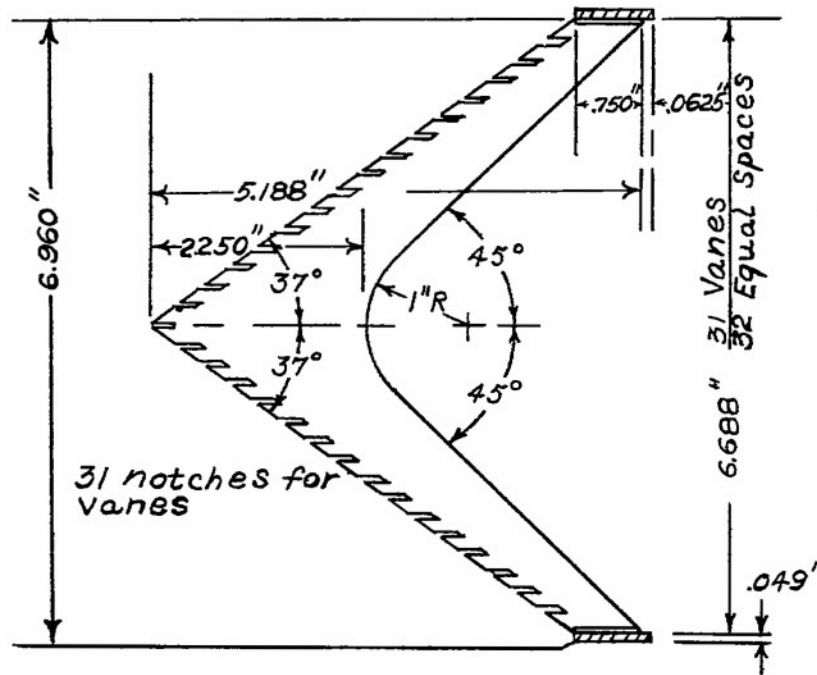
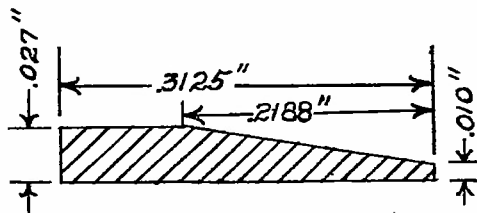

Figure 1.- Turbojet inlet screen and starter-motor housing.



(a) View of screen showing strut detail and vane location.



(b) Typical vane cross section of configuration I.



(c) Vane cross section of configuration II.

NATIONAL ADVISORY
COMMITTEE FOR AERONAUTICS

Figure 2.- Details of screen struts and vanes.

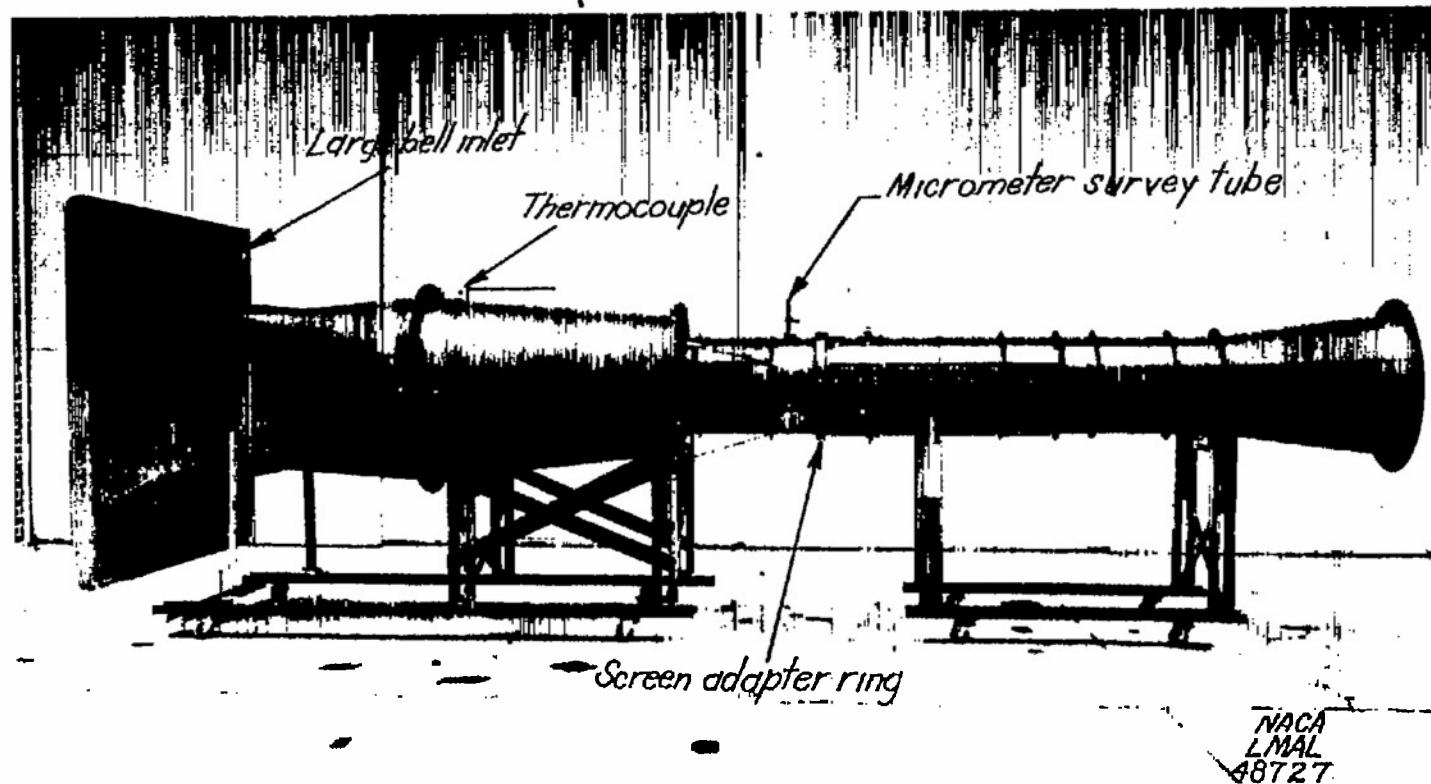
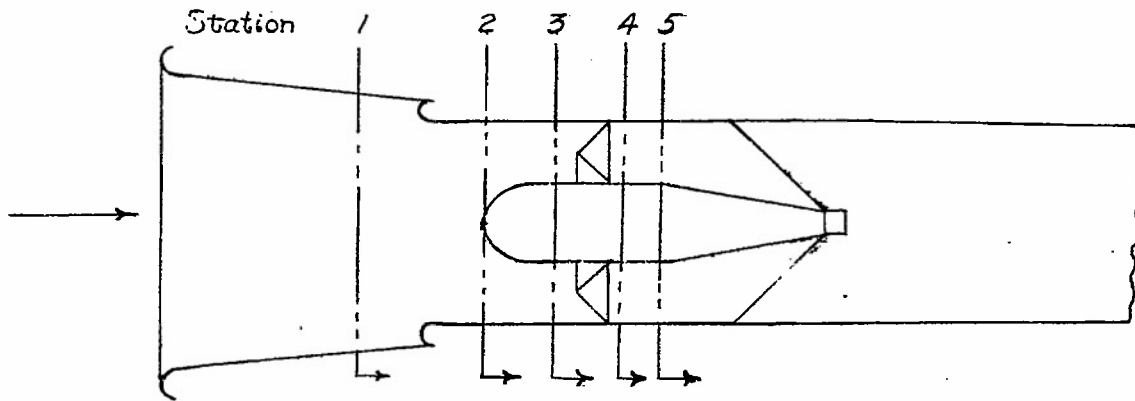
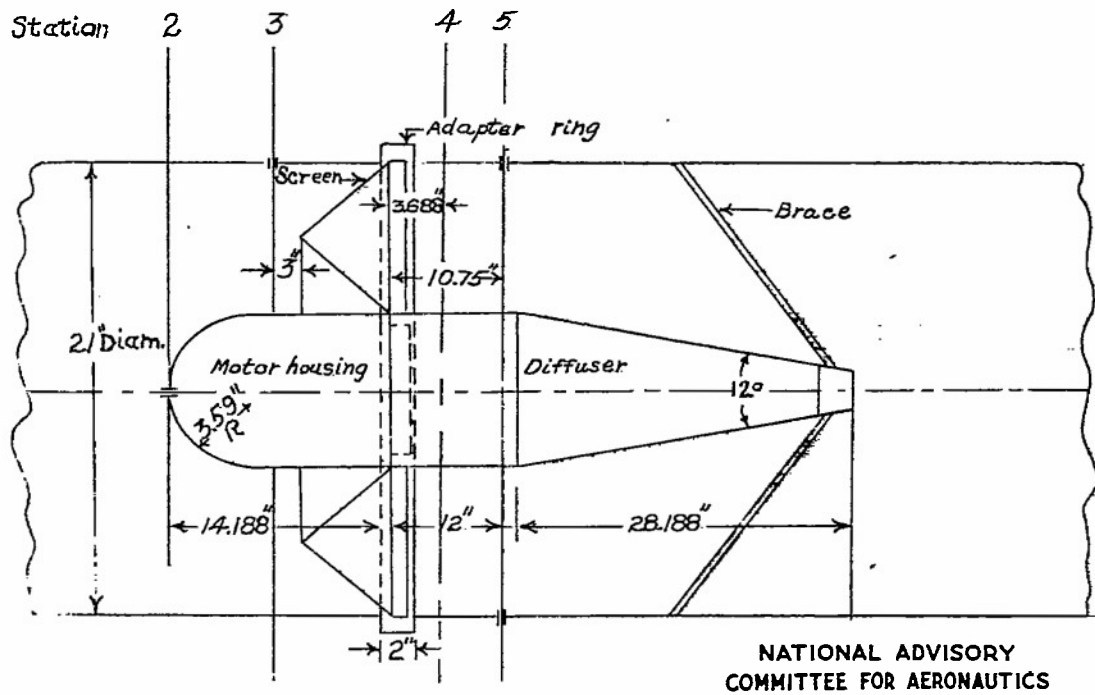

Figure 3.- General view of ducting and apparatus.



(a) Schematic view of all stations.



NATIONAL ADVISORY
COMMITTEE FOR AERONAUTICS

(b) Detail location of measuring stations.

Figure 4.- Measuring-station location and details.

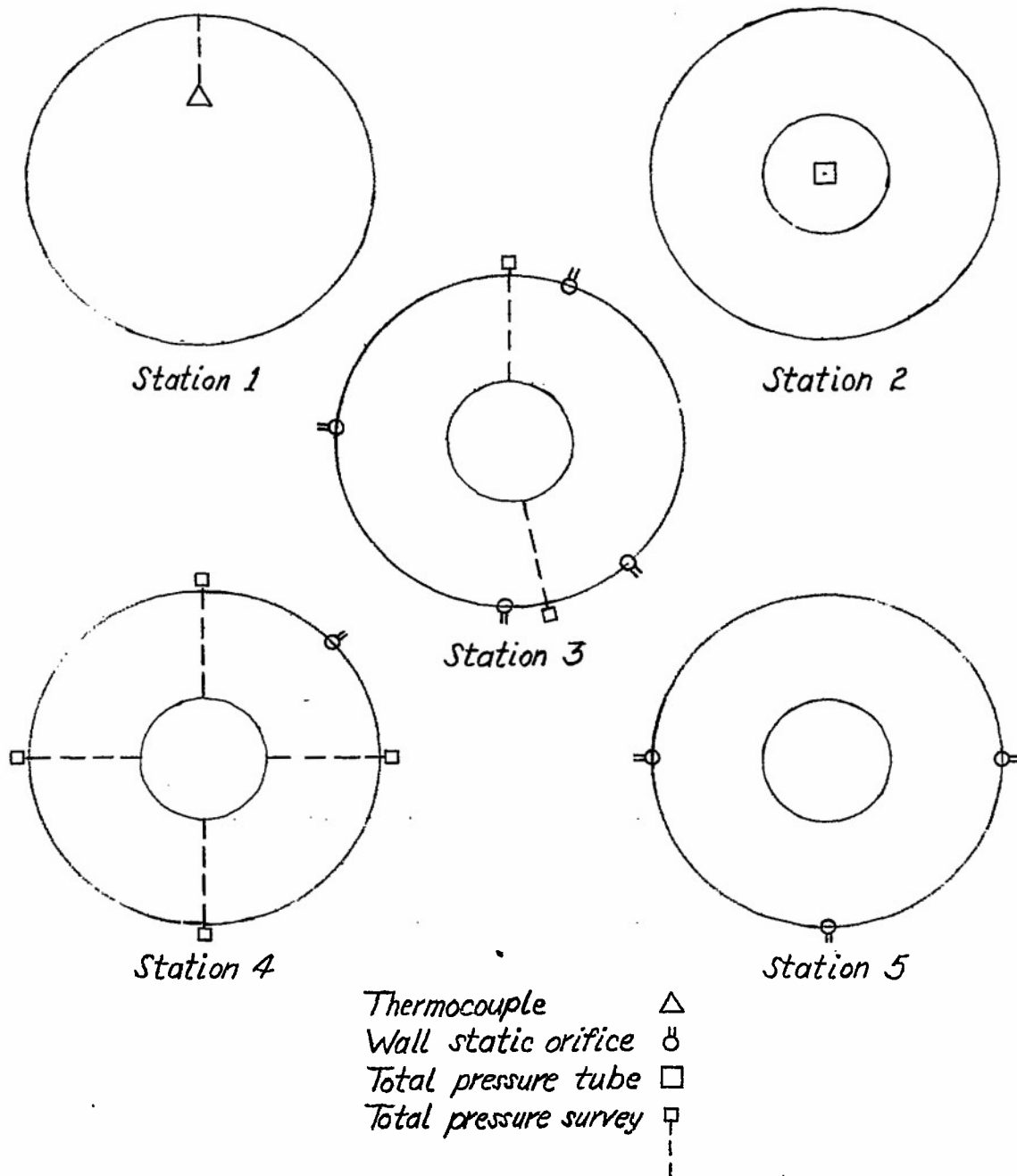

NATIONAL ADVISORY
COMMITTEE FOR AERONAUTICS

Figure 5.- Sections through all stations showing instrumentation.

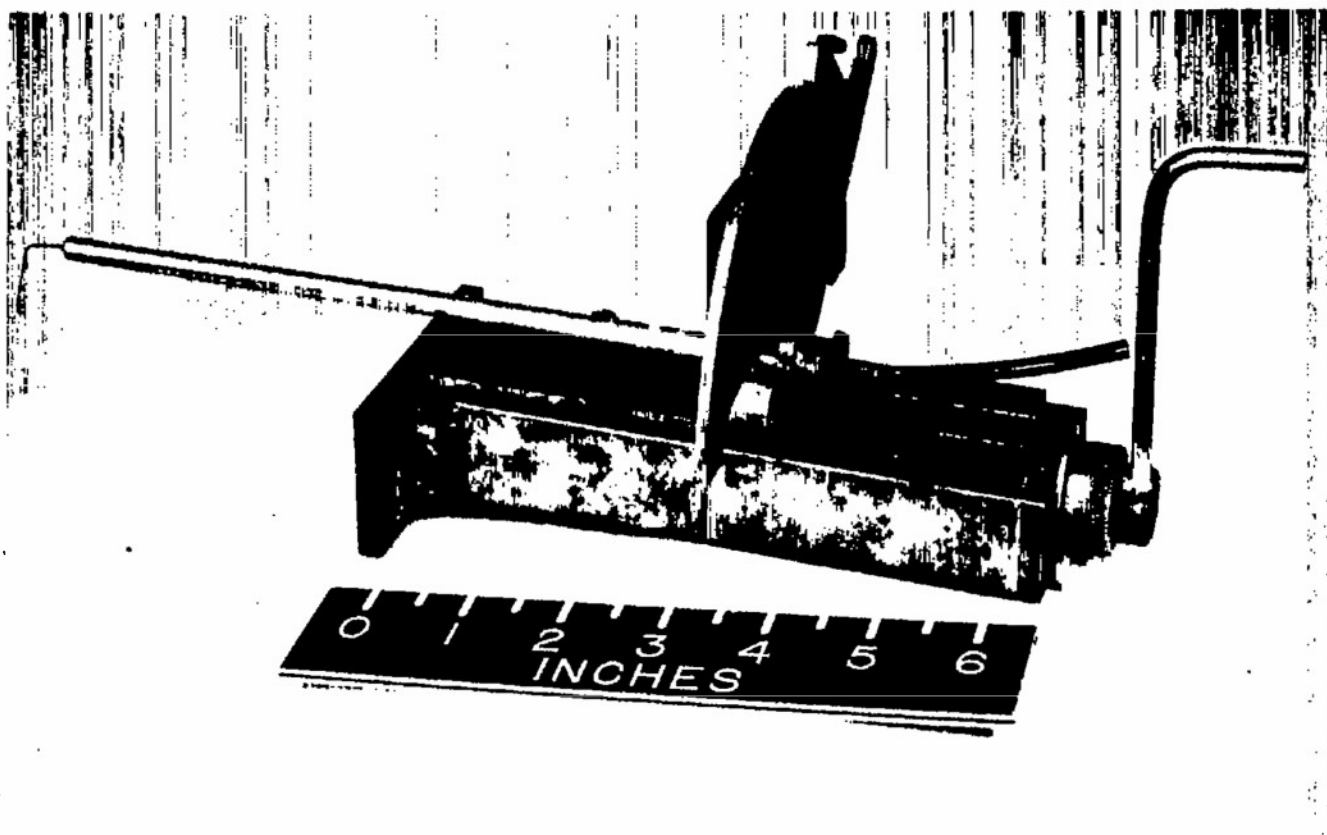

Figure 6.- Typical micrometer survey tube.

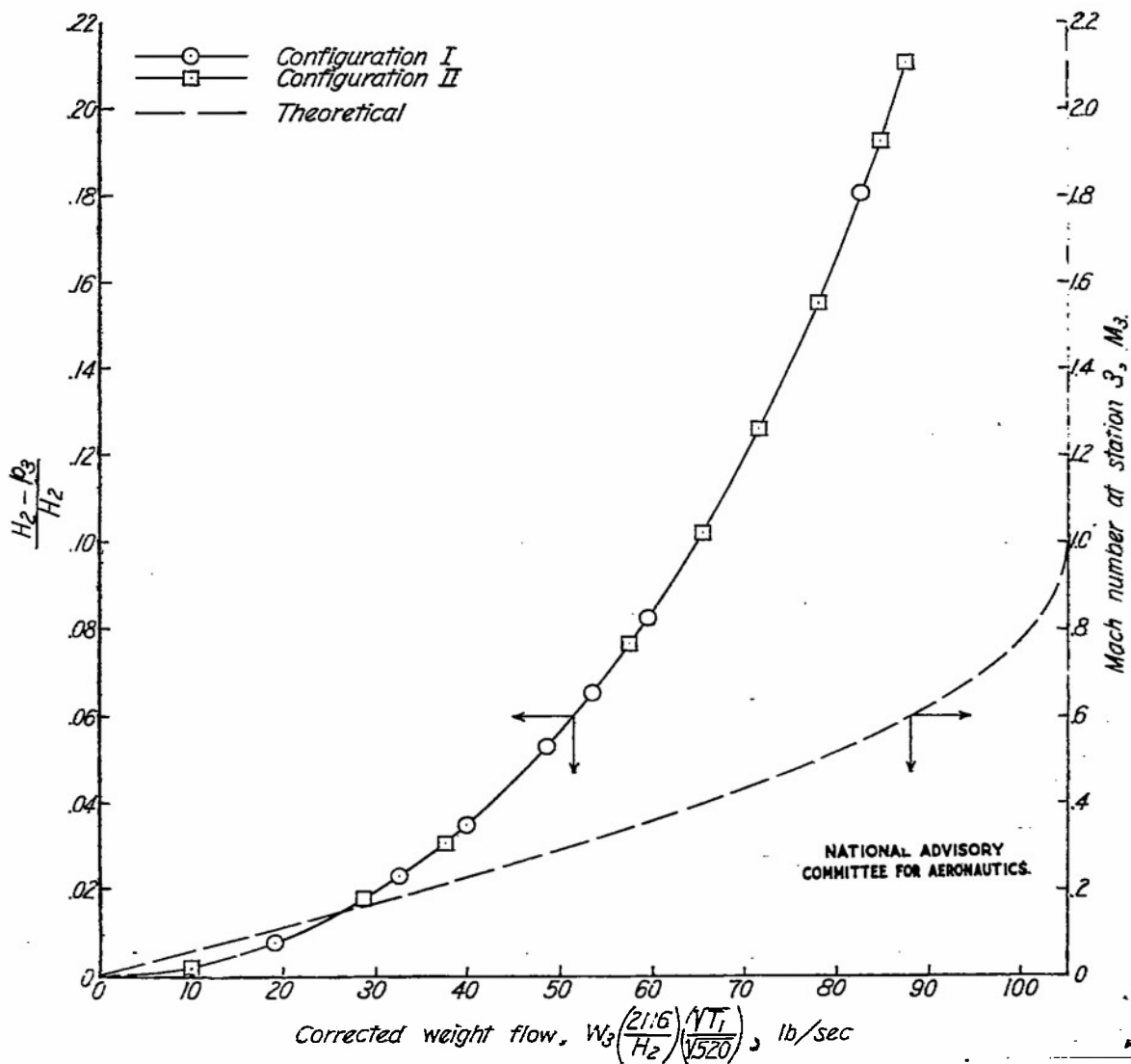

Figure 7.- Calibration curve for approach section and curve of theoretical relation of Mach number to weight flow.

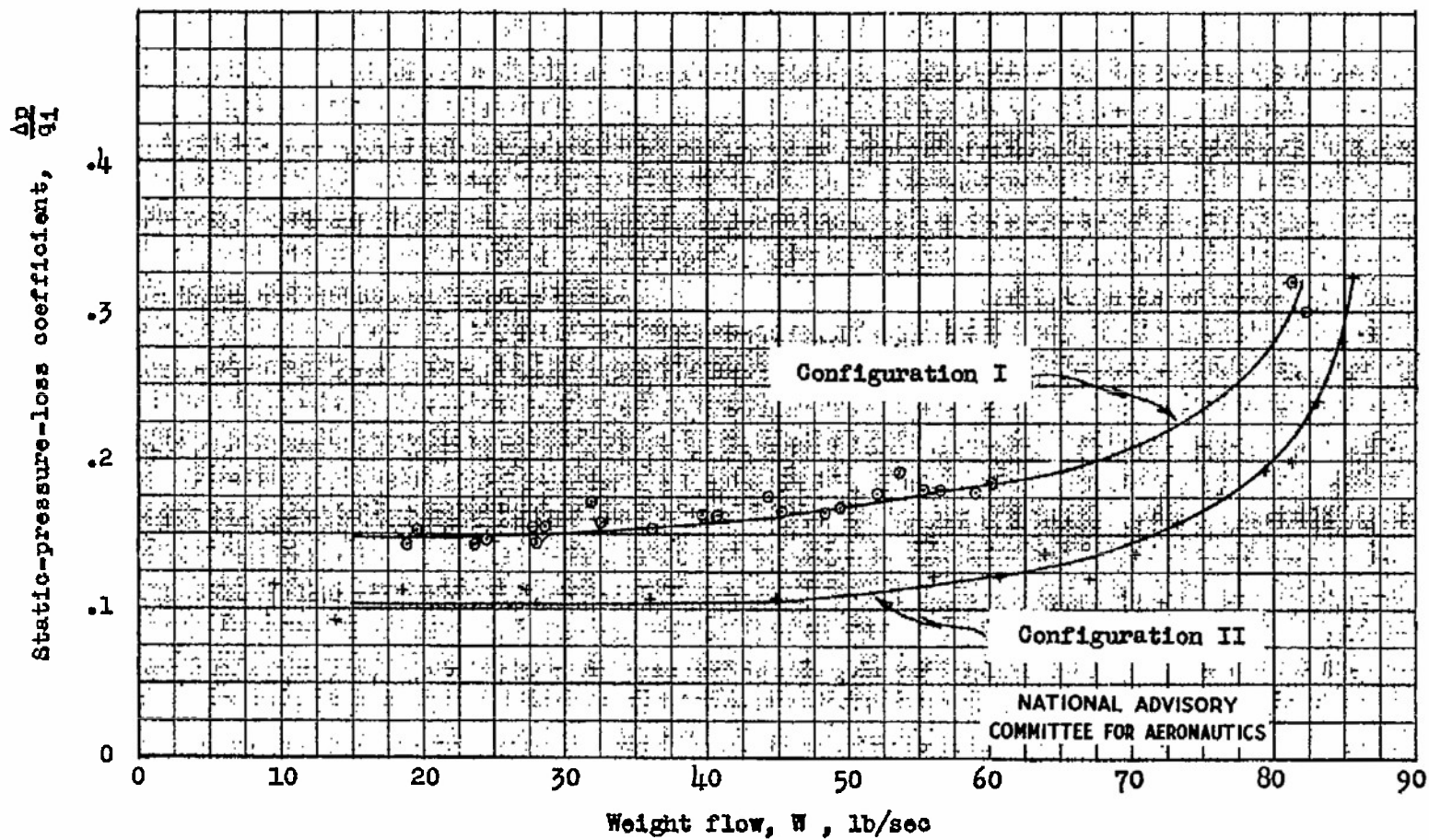

Figure 8.- Static-pressure-loss coefficient plotted against weight flow.

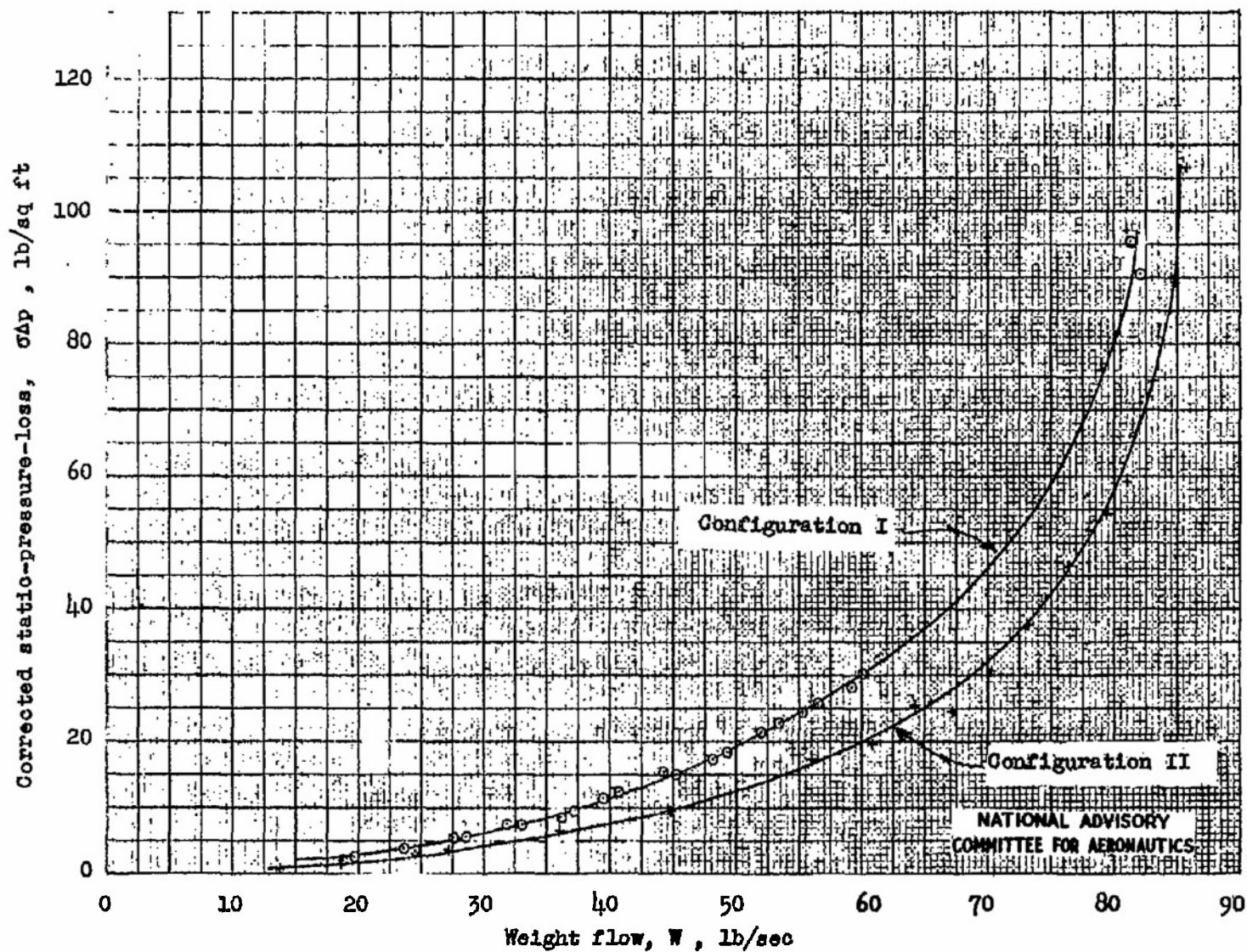

Figure 9.- Corrected static-pressure-loss plotted against weight flow.

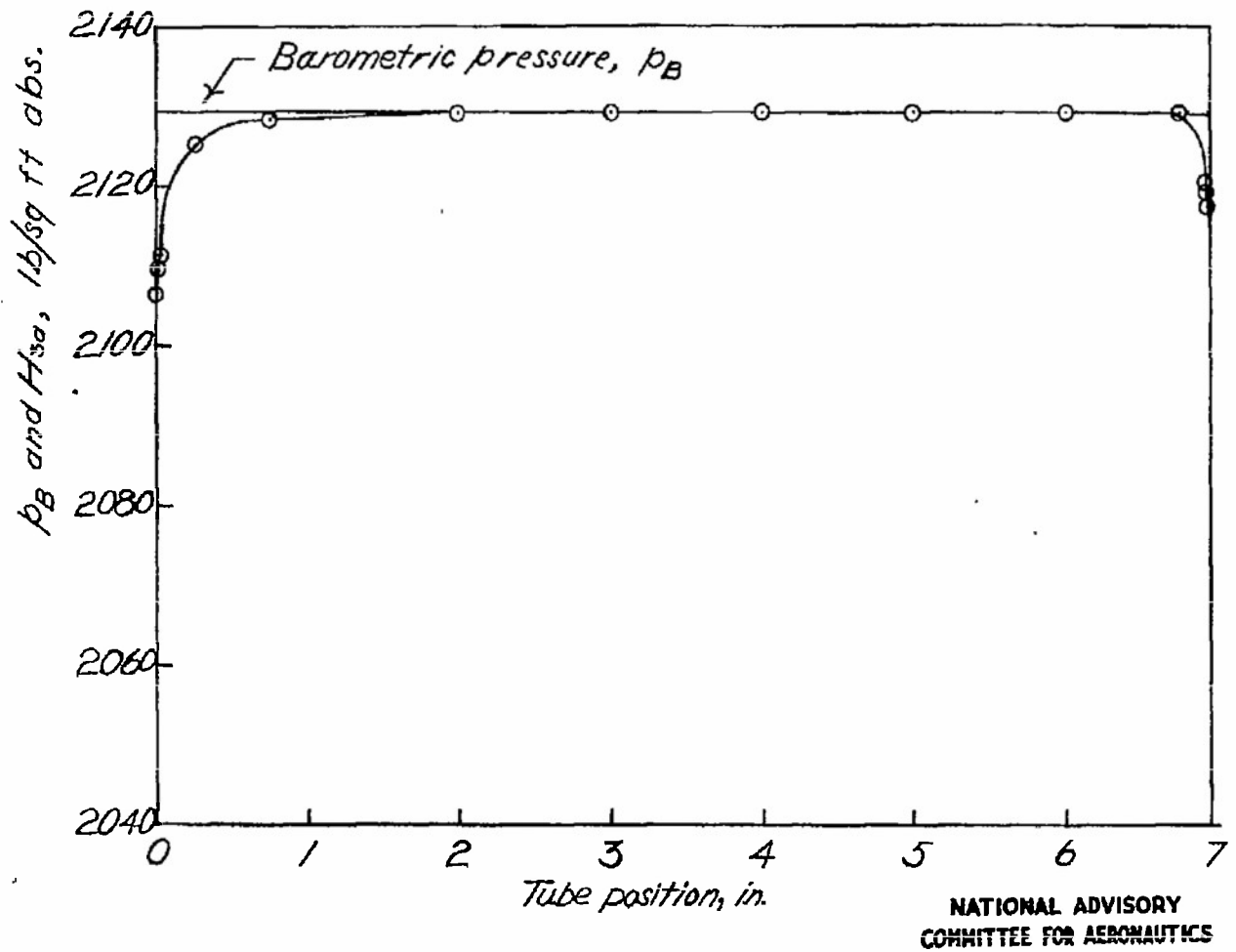

Figure 10.- Total pressure upstream of screen (station 3). Weight flow, 28.24 pounds per second.

NATIONAL ADVISORY
COMMITTEE FOR AERONAUTICS

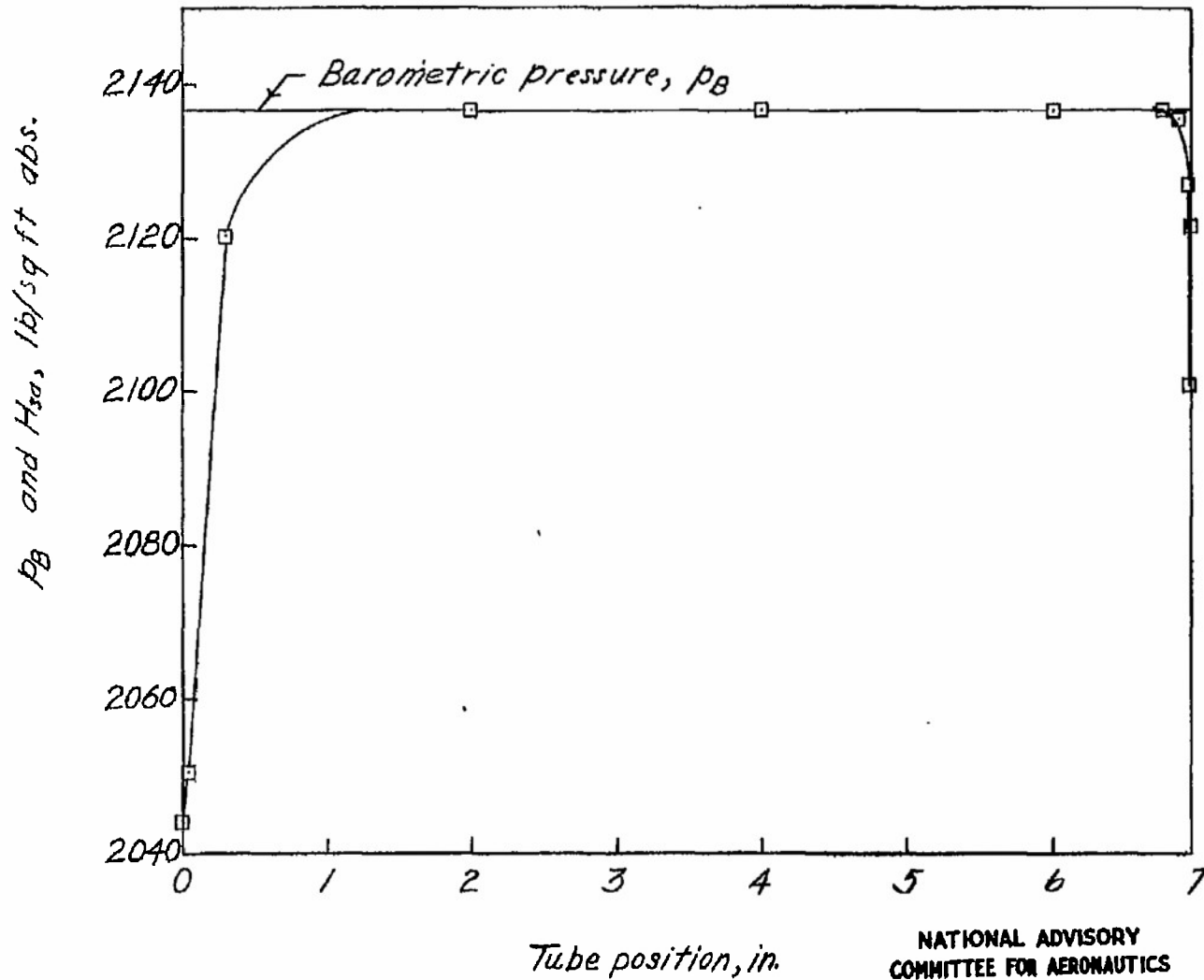
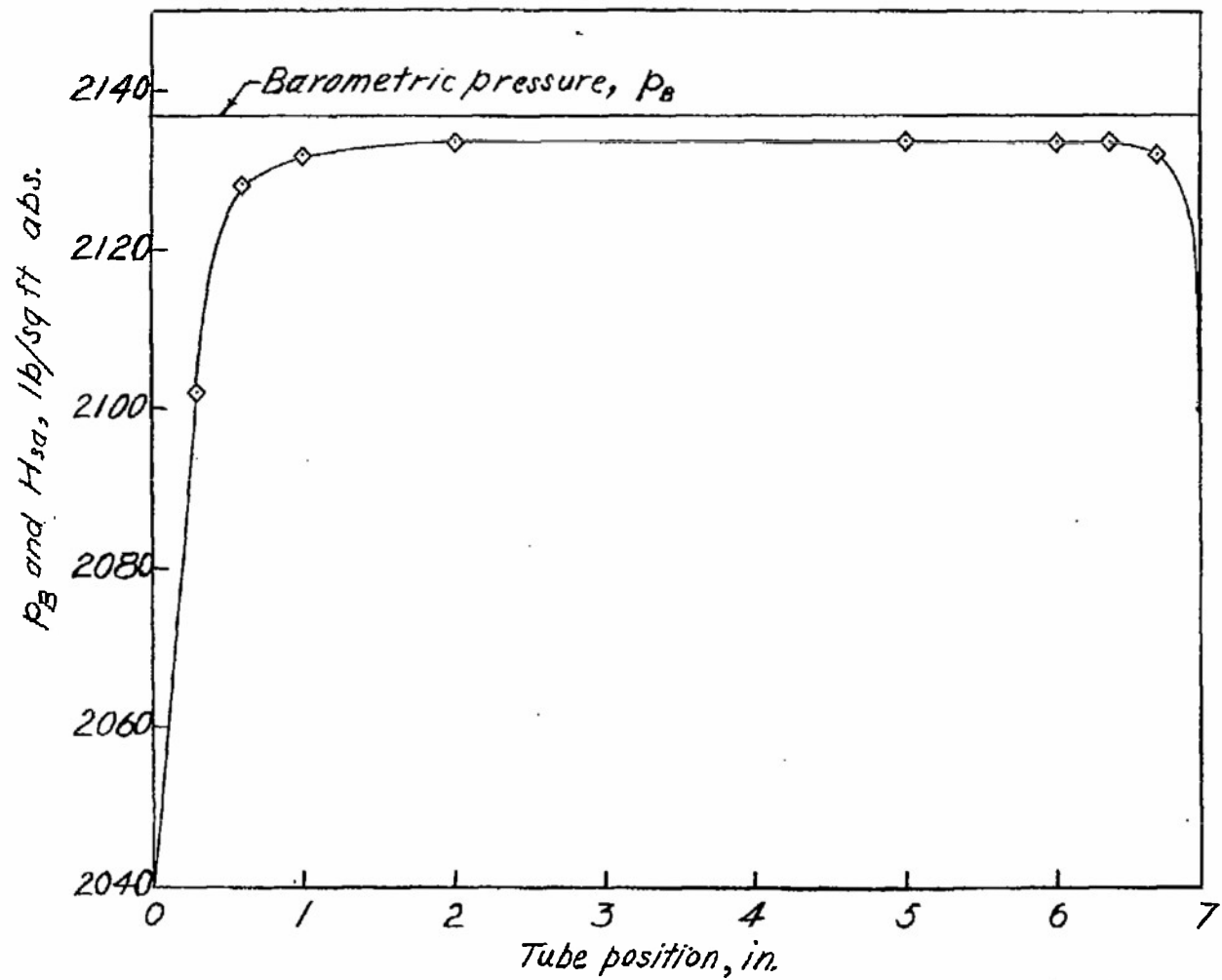
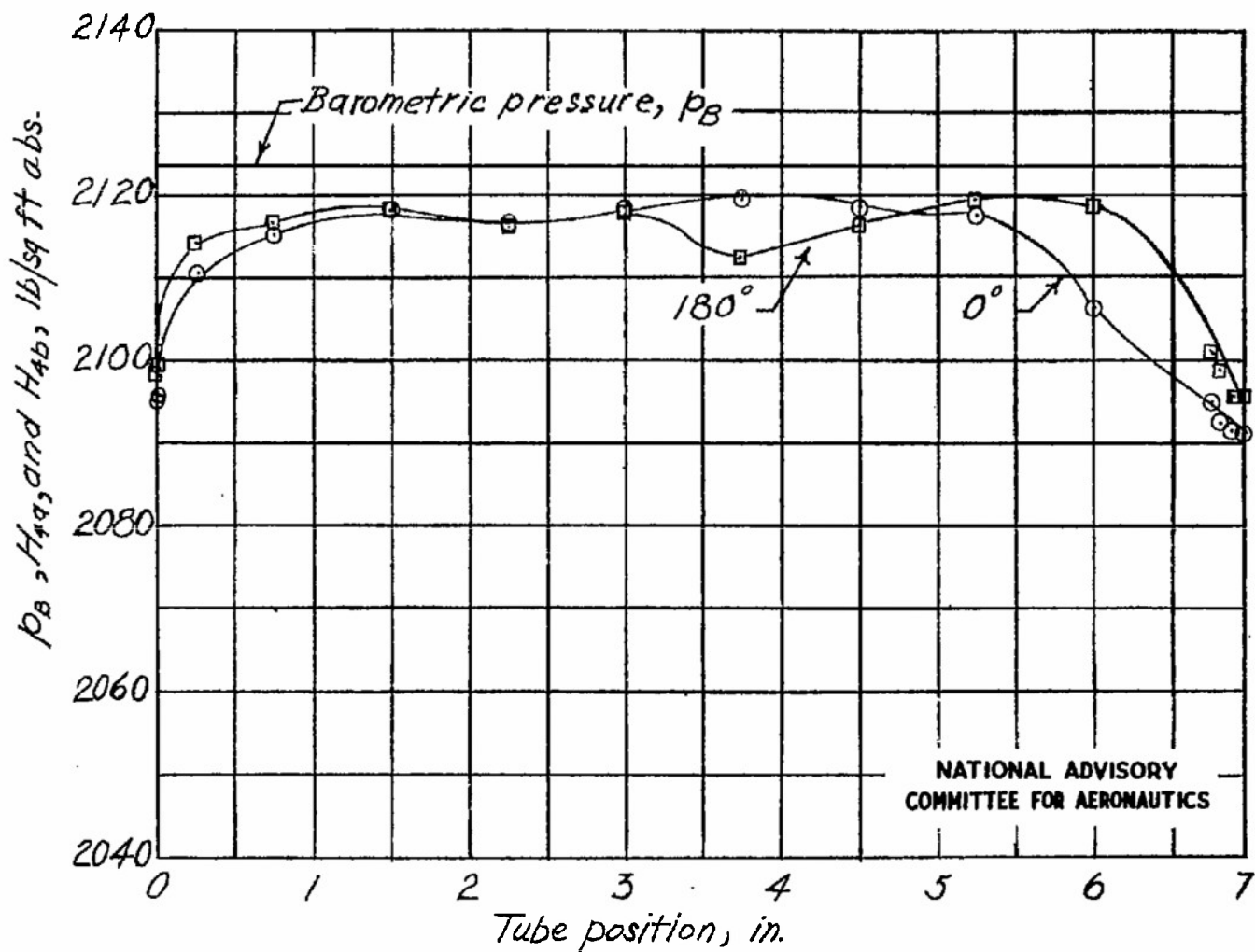

Figure 11.- Total pressure upstream of screen (station 3). Weight flow, 56.81 pounds per second.



NATIONAL ADVISORY
COMMITTEE FOR AERONAUTICS

Figure 12.- Total pressure upstream of screen (station 3). Weight flow, 82.15 pounds per second.



(a) Circumferential position, 0° and 180° ; weight flow, 29.67 pounds per second.

Figure 13.- Total pressure downstream of screen (station 4). Configuration I.

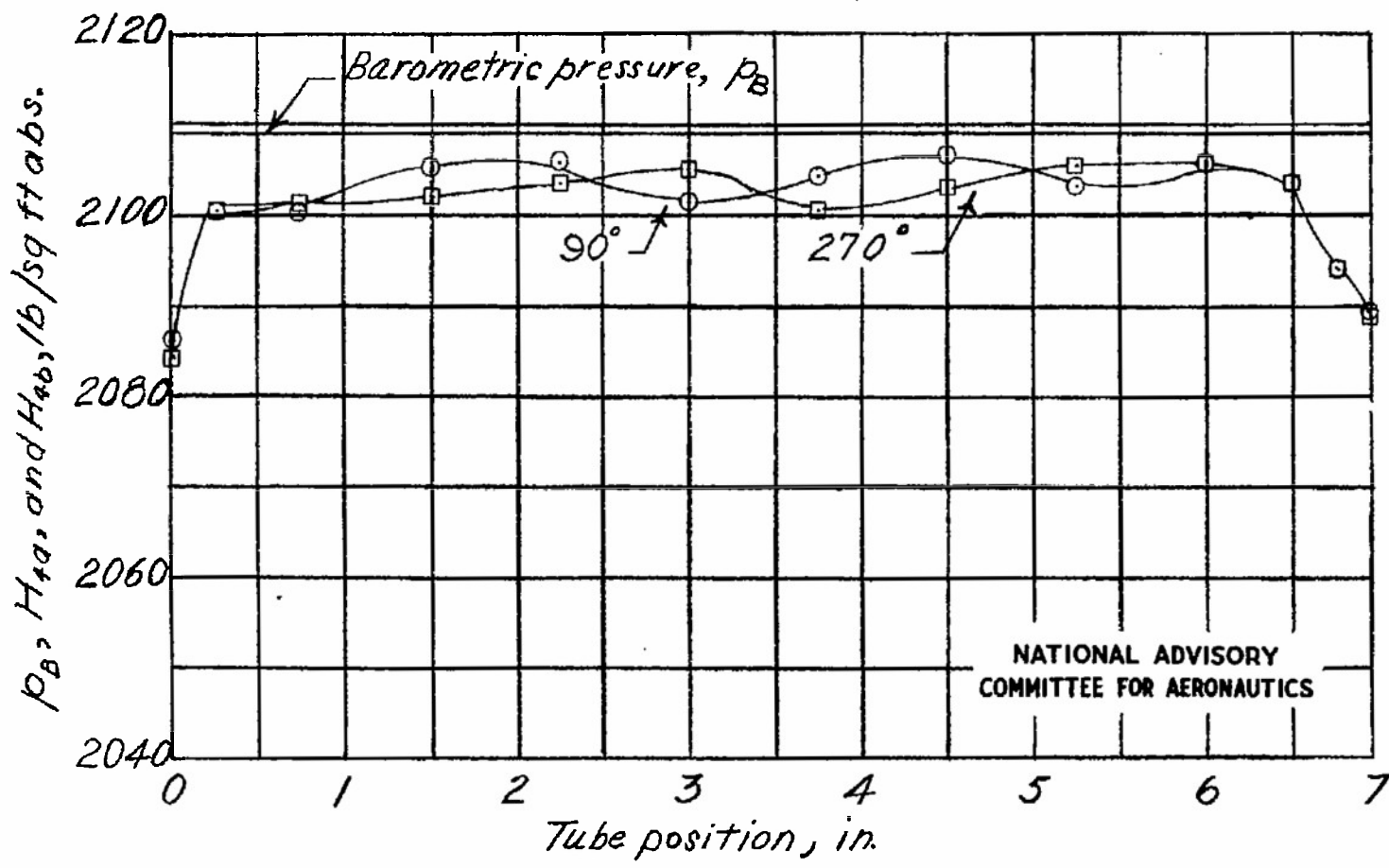

(b) Circumferential position, 90° and 270°; weight flow, 29.74 pounds per second.

Figure 13.- Continued.

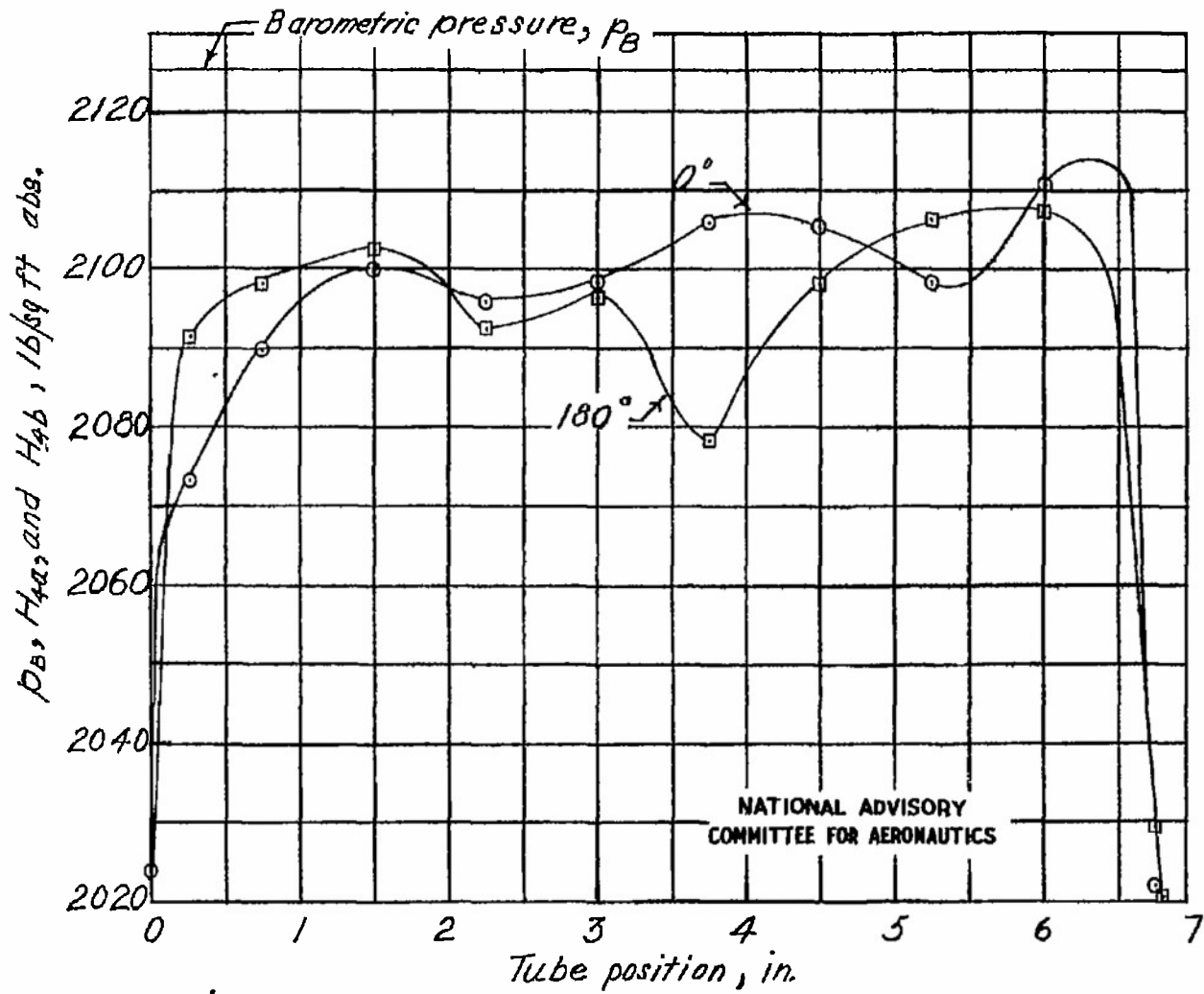

(c) Circumferential position, 0° and 180°; weight flow, 59.35 pounds per second.

Figure 13.- Continued.

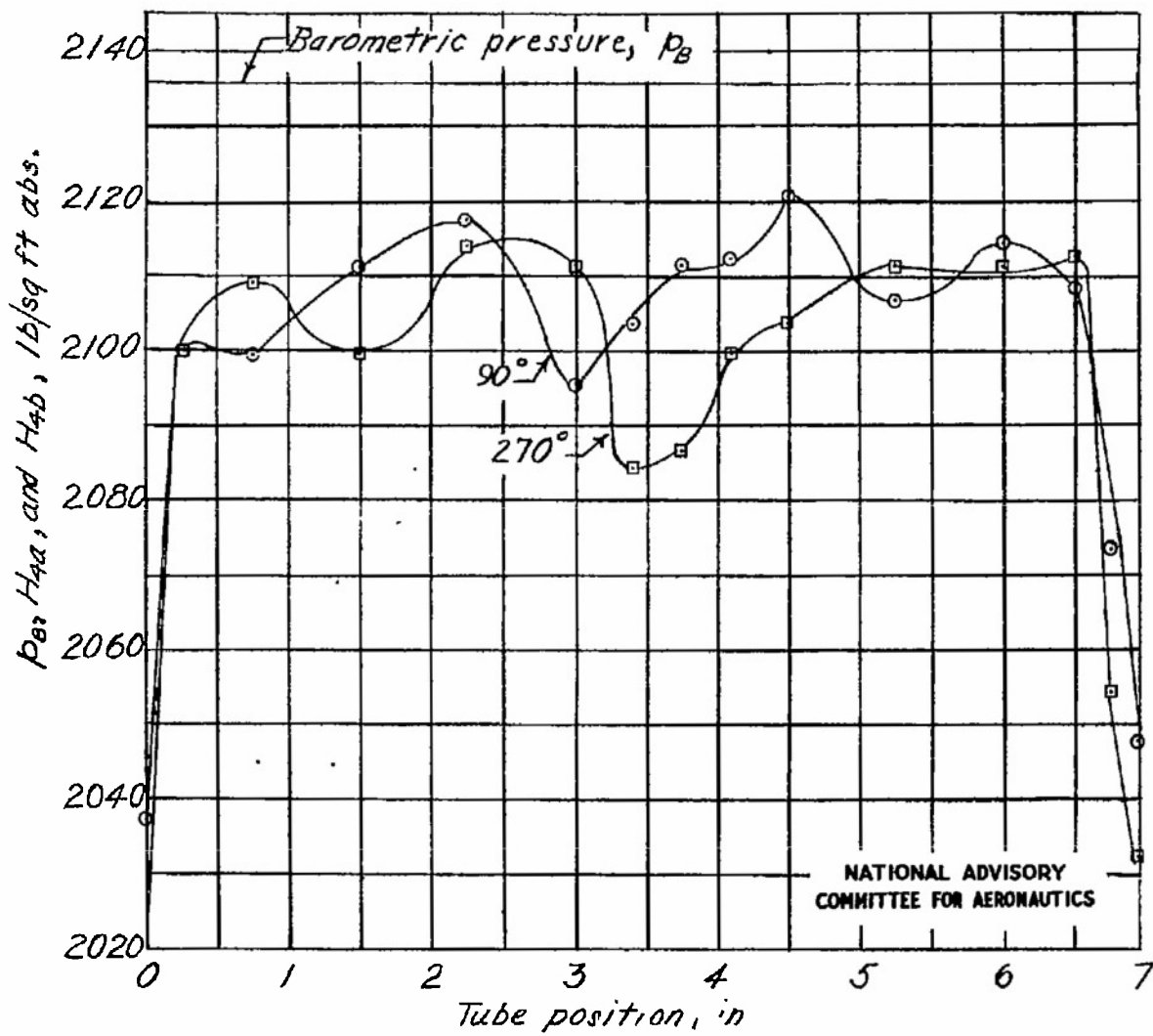

(d) Circumferential position, 90° and 270°; weight flow, 60.46 pounds per second.

Figure 13.- Continued.

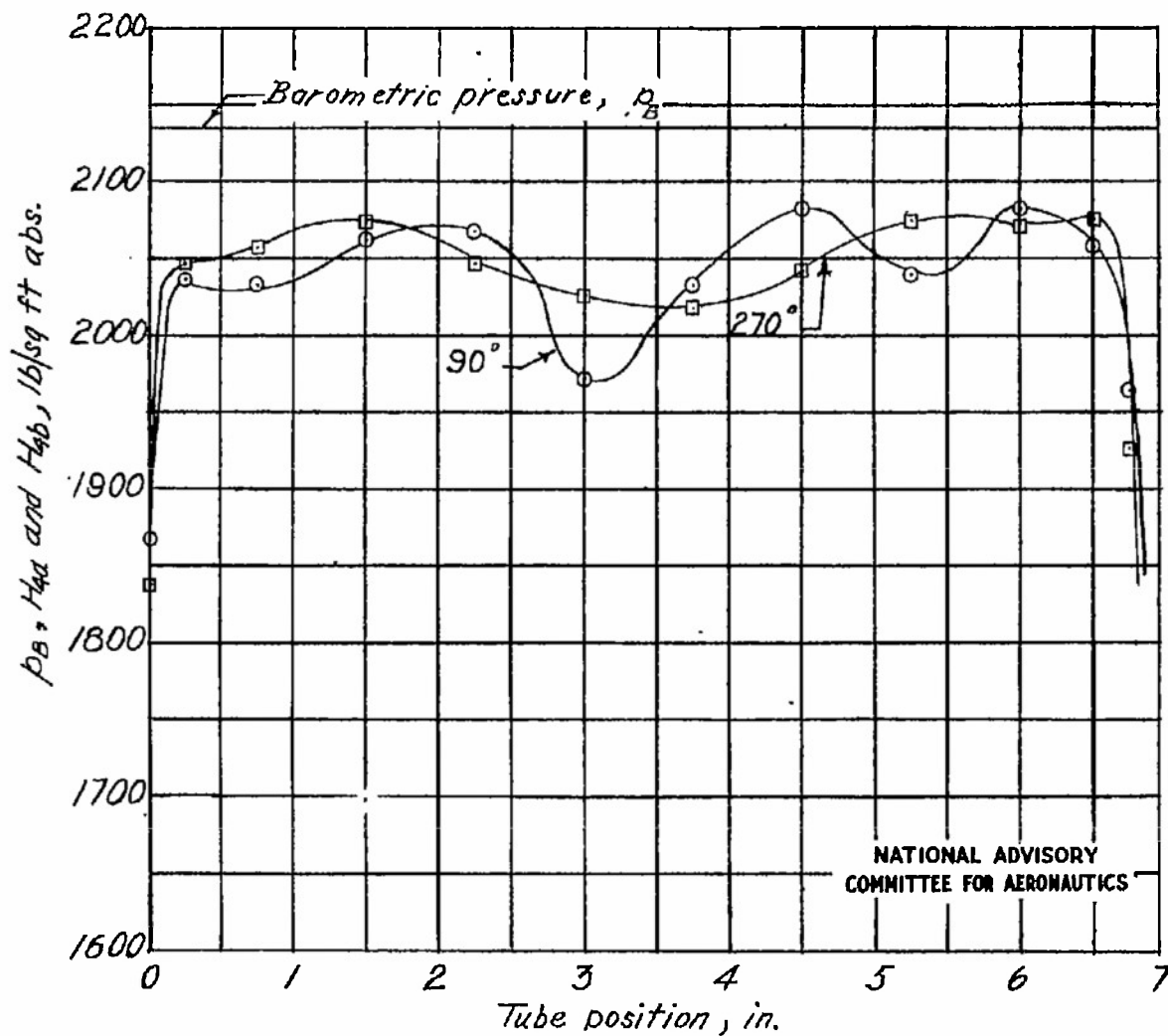

(e) Circumferential position, 90° and 270°; weight flow, 89.63 pounds per second.
 (Note that vertical scale changes from that on previous figures.)

Figure 13.- Concluded.

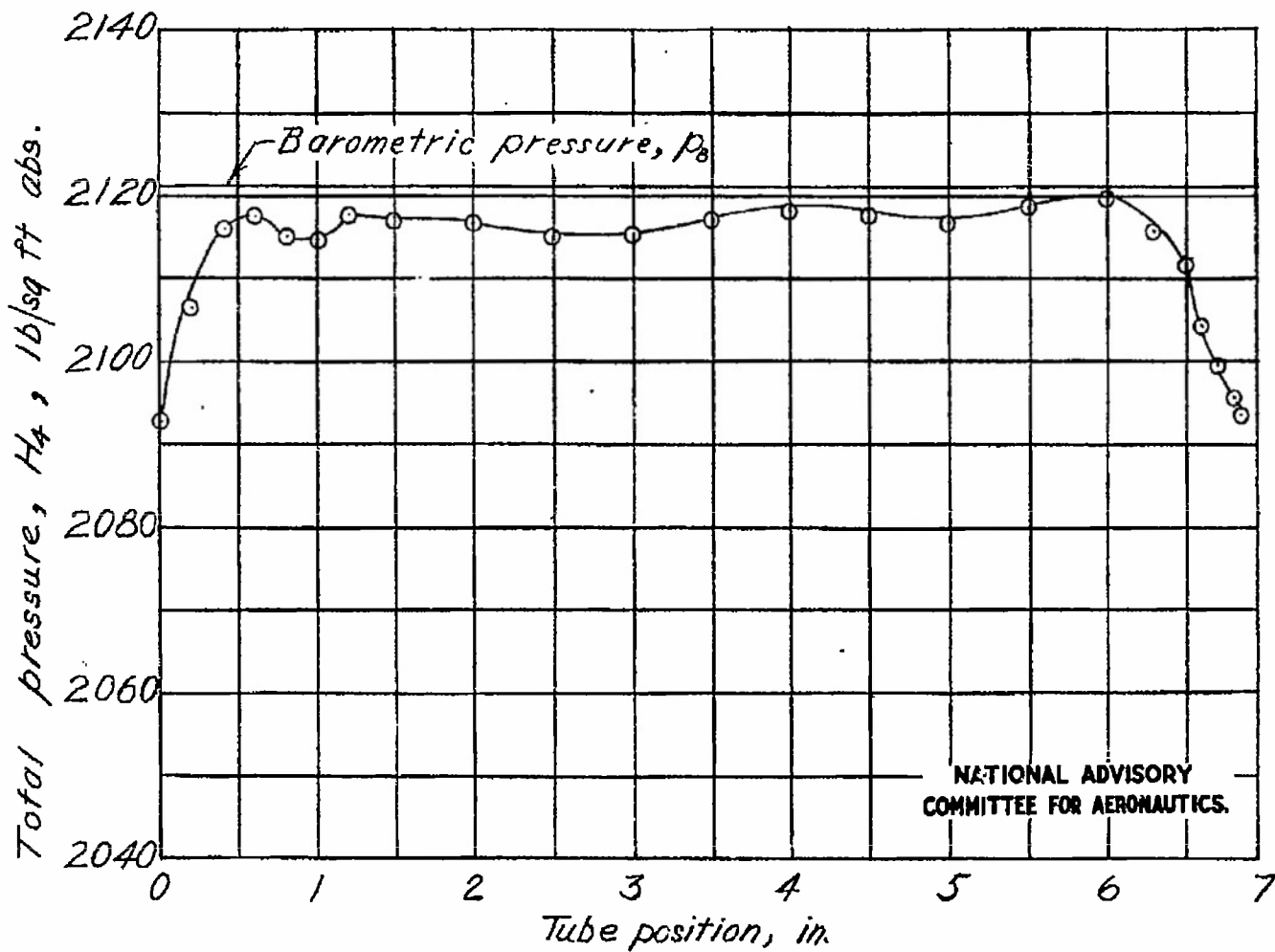

(a) Circumferential position, 90° ; weight flow, 28.26 pounds per second.

Figure 14.- Total pressure downstream of screen (station 4). Configuration II.

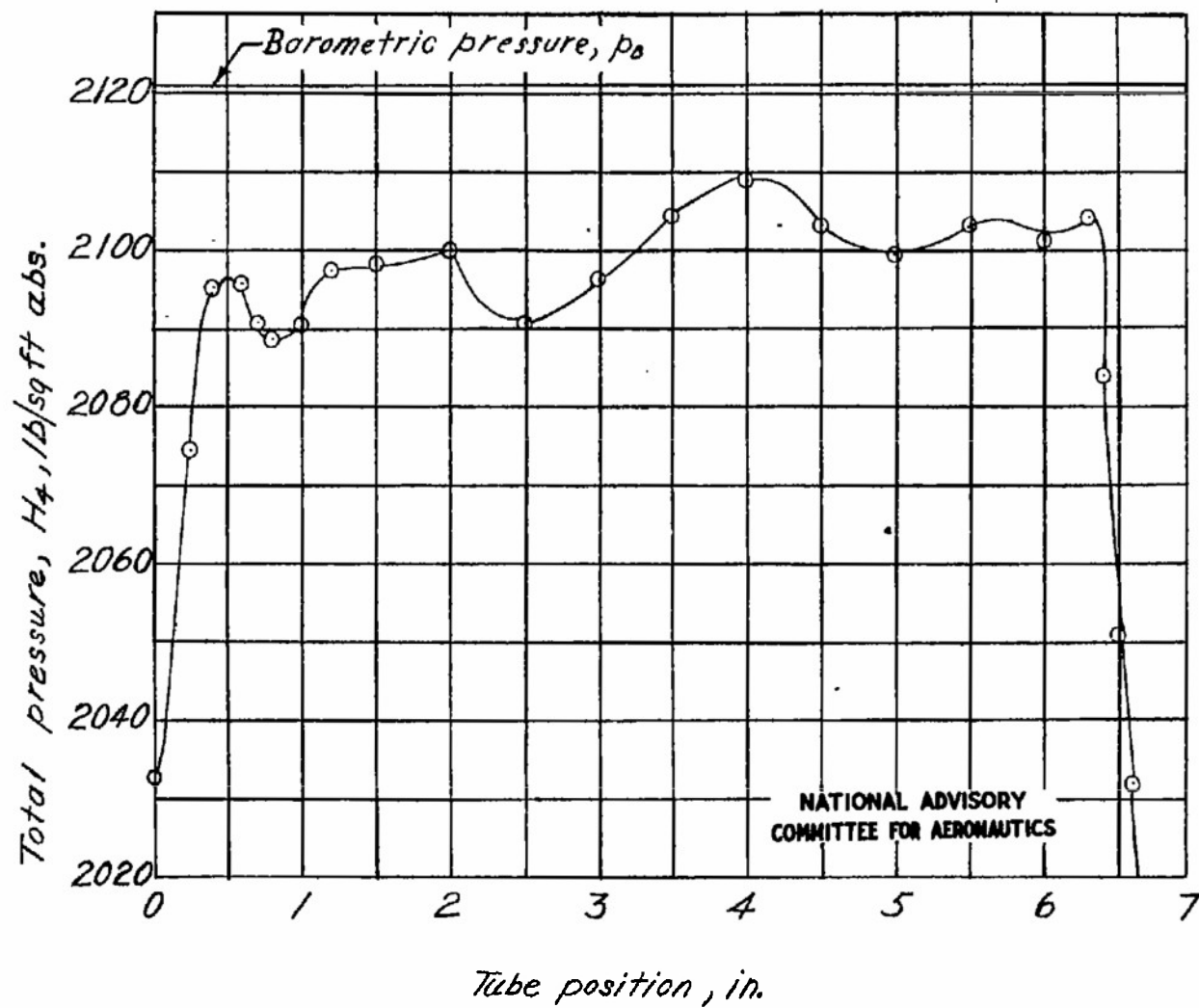

(b) Circumferential position, 90° ; weight flow, 56.26 pounds per second.

Figure 14.- Concluded.

TITLE: Investigation of the Pressure-Loss Characteristics of a Turbojet Inlet Screen

AUTHOR(S): Lankford, J. L.

ORIGINATING AGENCY: National Advisory Committee for Aeronautics, Washington, D. C.

PUBLISHED BY: (Same)

ATI- 12045

REVISION
(None)

ORIG. AGENCY NO.
TN-1418

PUBLISHING AGENCY NO.

U

DATE	DOC. CLASS.	COUNTRY	LANGUAGE	PAGES	ILLUSTRATIONS
Sept '47	Unclass.	U. S.	Eng.	26	photos, graphs, drwgs

ABSTRACT:

Investigation was made to determine static-pressure losses and total-pressure distribution of a turbojet inlet screen. Tests were made of two screen configurations, one with vane leading edges square and rough and the other with edges rounded. Results indicated that pressure losses increased and total-pressure variations became more pronounced with increasing weight flow. Rounding of the vane leading edges reduced static-pressure losses considerably and slightly improved total pressure patterns.

DISTRIBUTION: Request copies of this report only from Originating Agency

DIVISION: Power Plants, Jet and Turbine (5) *27*

SECTION: Induction System (2) *2*

SUBJECT HEADINGS:

Engine, Turbojet - Inlet screens (34153)

ATI SHEET NO.: R-5-2-2

Air Documents Division, Intelligence Department
Air Materiel Command

AIR TECHNICAL INDEX

Wright-Patterson Air Force Base
Dayton, Ohio

T

-J

(23)

* furpo set inlets

Static Pressure

P
21/5