

~~CONFIDENTIAL~~

~~RESTRICTED~~
SECURITY INFORMATION

Inactive
JUN 1948

UNCLASSIFIED ~~783~~
~~224~~
C.2

~~RESTRICTED~~
SECURITY INFORMATION
NACA

By authority of *H. G. Snyder* date *6-11-53*

RESEARCH MEMORANDUM

per NACA Release form #1453
By HSR, 7-16-53.

CALCULATED CONDENSER PERFORMANCE FOR A STEAM-TURBINE
POWER PLANT FOR AIRCRAFT

By Leroy V. Humble, and Ronald B. Doyle

Flight Propulsion Research Laboratory
Cleveland, Ohio

~~CLASSIFICATION CHANGED~~

~~CONFIDENTIAL~~

To ~~SECRET~~ *EA 10501*

By authority of *J. M. Crowley*
1/12/54

CLASSIFIED DOCUMENT
Date *12/14/53*
This document contains classified information affecting the National Defense of the United States within the meaning of the Espionage Act, USC 50:31 and 32. Its transmission or the revelation of its contents in any manner to an unauthorized person is prohibited by law. Information so classified may be imparted only to persons in the military and naval services of the United States, appropriate civilian officers and employees of the Federal Government who have a legitimate interest therein, and to United States citizens of known loyalty and discretion who of necessity must be informed thereof.

CLASSIFICATION CANCELLED

Author *LC 7-23-53* Date *11/11/54*
By *LC 11/11/54*
TECHNICAL EDITING WAIVED

NATIONAL ADVISORY COMMITTEE FOR AERONAUTICS

WASHINGTON
May 20, 1948

UNCLASSIFIED

~~CONFIDENTIAL~~

~~CONFIDENTIAL~~

NACA
LANGLEY MEMORIAL AERONAUTICAL
LABORATORY
Langley Field, Va.

NATIONAL ADVISORY COMMITTEE FOR AERONAUTICS

RESEARCH MEMORANDUM



CALCULATED CONDENSER PERFORMANCE FOR A STEAM-TURBINE

POWER PLANT FOR AIRCRAFT

By Leroy V. Humble, and Ronald B. Doyle

SUMMARY

As part of an investigation of the application of nuclear energy to aircraft, calculations have been made to determine the effect of several operating conditions on the performance of condensers for steam-turbine power plants. The analysis covered a range of turbine-inlet pressures from 1000 to 1800 pounds per square inch absolute and turbine-outlet pressures from 10 to 200 pounds per square inch absolute for various condenser cooling-air pressure drops, flight speeds, and altitudes. Some calculations were made to determine the advisability of using a cooling fan in conjunction with the steam condenser.

A rough estimate of the total power-plant weight including propeller but excluding reactor is included along with values of the ratio of disposable load (load-carrying capacity) to airplane gross weight for a steam-turbine-powered aircraft at one set of turbine operating conditions and two flight conditions.

At a turbine-inlet pressure of 1400 pounds per square inch absolute and a turbine-inlet temperature of 866° F, the minimum specific condenser weight was 257 pounds per 1000 net thrust horsepower and the minimum specific condenser frontal area was 16.7 square feet per 1000 net thrust horsepower. These values occurred at a turbine-outlet pressure of 100 pounds per square inch absolute, a flight speed of 500 miles per hour, and an altitude of about 15,000 feet.

INTRODUCTION

One possible method of application of nuclear energy to aircraft propulsion is the use of a nuclear reactor as the heat source in a steam-turbine power plant. Aside from reactor considerations, the condenser, due to its excessive size and internal drag power, presents an important problem in the use of such a system.

UNCLASSIFIED

The results of an analysis to determine the effect of steam-cycle operating conditions, cooling-air pressure drop, altitude, and flight speed on the frontal area, weight, and internal drag of the condenser are reported. The analysis covers a range of turbine-inlet pressures, turbine-outlet pressures, cooling-air pressure drops, altitudes, and flight speeds.

An estimate of the total power-plant weight, excluding the weight of the nuclear reactor, was made for one set of turbine operating conditions and two flight conditions and was used to calculate the percentage of the gross weight of the airplane that would be available for carrying the reactor and cargo.

Condenser computations were based on an aluminum heat exchanger of the aircraft fin-and-tube type. Heat-dissipation rates and some cooling-air pressure-drop data were obtained from charts supplied by the heat-exchanger manufacturer.

METHODS OF ANALYSIS

The power plant was considered to consist of a nuclear-reactor boiler, a steam turbine, an air-cooled condenser, and the necessary pumps, valves, and piping. The boiler feed pump was assumed to be driven directly by the turbine and the net shaft power delivered to a propeller.

Calculations were made to determine the effect of steam-cycle operating conditions, ratio of cooling-air static-pressure drop to compressible dynamic pressure ($\Delta p/q$), altitude, and flight speed on condenser size and internal drag power. Some additional calculations were made to determine the effect of a cooling fan on condenser performance.

Calculations were made for two flight conditions to determine what percentage of the gross weight of a steam-turbine-powered airplane would be available for disposable load, that is, for the nuclear reactor and cargo.

The calculations covered a range of turbine-outlet pressures from 10 to 200 pounds per square inch absolute and a range of $\Delta p/q$ from 0.10 to 0.60 at turbine-inlet pressures of 1000, 1400, and 1800 pounds per square inch absolute for a flight speed of 500 miles per hour and an altitude of 30,000 feet. For each combination of turbine-inlet and turbine-outlet pressure, a turbine-inlet temperature was selected that would give saturated steam

(100-percent quality) at the turbine outlet. A range of flight speeds from 100 to 500 miles per hour was investigated at altitudes of sea-level, 15,000, and 30,000 feet for turbine-inlet and turbine-outlet pressures of 1400 and 100 pounds per square inch absolute, respectively.

For all calculations except those involving power-plant-weight estimates, the steam rate was adjusted to give 1000 net shaft horsepower from the turbine with an adiabatic efficiency of 85 percent. The 1000 horsepower was then supplied to a propeller having an efficiency of 85 percent.

Condenser calculations were based on an aircraft fin-and-tube-type heat exchanger manufactured by Harrison Radiator Division, General Motors Corporation having a core weight, including tube headers but excluding inlet and outlet steam tanks, of 15.4 pounds per square foot of core frontal area. Several core configurations for the fin-and-tube-type construction were investigated and the exchanger with the core structure, shown schematically in figure 1, was found to give the best performance. Heat-dissipation rates were determined from charts supplied by the heat-exchanger manufacturer. Cooling-air pressure drops were determined from the manufacturer's charts modified to account for the effects of altitude and higher heat loading.

For a given heat rejection to the cooling air by the condenser and cooling-air pressure drop, the required condenser frontal area and weight and the weight flow of cooling air were determined from the modified charts. The internal drag power of the condenser was then calculated from the change in momentum of the cooling air. The net thrust power was taken as the algebraic difference between the propeller thrust power (product of turbine power and propeller efficiency) and the internal drag power of the condenser. Specific condenser weight and frontal area were then computed from the net thrust power and the weight and frontal area of the condenser.

The calculations of disposable load, which were based on 5000 net shaft horsepower from the turbine, involved the determination of the nacelle drag power and an estimation of the total power-plant weight including propeller, engine mountings, air ducting, and controls. A lift-to-drag ratio of 18 for the airplane without nacelles and a ratio of structural weight to gross weight of 0.4 were assumed. One calculation was made assuming the condenser to be so installed in the wings that no condenser external drag was involved and another calculation was made for the condenser enclosed in a nacelle.

Army standard air (99° F at sea level) was used for all calculations. Details of the calculations are presented in the appendix.

838

RESULTS AND DISCUSSION

Steam-cycle performance. - The effect of turbine-outlet pressure on cycle efficiency, steam rate, turbine-inlet temperature, reactor-heat input, heat rejected by condenser, and turbine-outlet temperature is shown in figure 2 for a net turbine horsepower of 1000 and a turbine efficiency of 85 percent at turbine-inlet pressures of 1000, 1400, and 1800 pounds per square inch absolute. Turbine-inlet temperatures were selected to give saturated steam of 100-percent quality at the turbine outlet.

As the outlet pressure increases and the inlet pressure decreases, the cycle efficiency decreases; the steam rate, the reactor-heat input, and the condenser heat rejection increase. The increases in reactor-heat input and condenser heat rejection are due to the decrease in cycle efficiency and the attendant increases in steam rate required to maintain constant turbine output.

Effect of turbine-outlet pressure on condenser performance. The effect of turbine-outlet pressure on net thrust power, condenser weight and frontal area, specific condenser weight (lb/1000 net thrust hp), and specific condenser frontal area (sq ft/1000 net thrust hp) is shown in figure 3 for turbine-inlet pressures of 1000, 1400, and 1800 pounds per square inch absolute, values of $\Delta p/q$ of 0.20, 0.40, and 0.60, and 1000 turbine horsepower.

As the outlet pressure is increased from its minimum value of 10 pounds per square inch, the condenser weight and frontal area show an initial decrease followed by an increase, with the minimum values occurring at an outlet pressure of about 40 pounds per square inch absolute. The condenser frontal area and weight are directly proportional to the heat to be removed by the condenser Q_C and inversely proportional to the initial temperature difference ΔT_1 between the condensing steam and the entering cooling air. In the low outlet-pressure range, ΔT_1 increases more rapidly than Q_C ; hence, there is an initial decrease in condenser area. Above an outlet pressure of about 40 pounds per square inch absolute, however, Q_C increases more rapidly than ΔT_1 and the area must also increase. The required frontal area decreases with increasing inlet pressure owing to the attendant decrease in heat rejection. (See fig. 2.)

838

The net thrust power increases with outlet pressure for most combinations of inlet pressure and $\Delta p/q$. The exceptions are at a $\Delta p/q$ of 0.60 at inlet pressures of 1000 and 1400 pounds per square inch absolute where the net thrust power reaches a maximum value and then decreases as the outlet pressure is further increased from its minimum value. (See fig. 3(c).) The changes in net thrust power are due to the combined effects of increased steam temperature and heat rejection on the cooling-air flow and temperature rise and hence on internal drag power (Meredith effect).

Net thrust power increases with increasing turbine-inlet pressure except at high turbine-outlet pressures for a $\Delta p/q$ of 0.20. (See fig. 3(a).) At constant outlet pressure, and hence constant outlet steam temperature, a decrease in inlet pressure increases the heat rejection and thus increases the required condenser size and total cooling-air flow. For most cases, this result means an increase in internal drag power with a consequent decrease in net thrust power. At a $\Delta p/q$ of 0.20 and high outlet pressures, however, the condenser has negative internal drag (thrust) and the increase in cooling-air flow resulting from the decreased turbine-inlet pressure increases this thrust and hence the net power. It may be noted that the propeller thrust horsepower is 850 (0.85×1000), and therefore condenser thrust and drag powers are the difference between values of net thrust power from the data figures and 850; positive values of the difference indicate thrust and negative values indicate drag.

Specific condenser weight and specific condenser frontal area have a minimum point at turbine-outlet pressures between approximately 30 and 100 pounds per square inch absolute for the range of inlet pressures and $\Delta p/q$ investigated. Minimum specific weights and areas occur at the maximum inlet pressure.

Although low turbine-outlet pressures are generally considered desirable in steam work as far as efficiency is concerned, in an aircraft installation low outlet pressures with the attendant low steam temperatures (low initial temperature differences ΔT_i) result in excessive condenser size. The decrease in steam-cycle efficiency attending operation at high outlet pressures is partly compensated for in aircraft installations by the decreased internal drag or, for some cases, by the increased thrust developed by the condenser as a result of the greater heat dissipation. Furthermore, operation at high outlet pressures would be advantageous from the consideration of decreased turbine weight.

Effect of cooling-air pressure drop on condenser performance. - The variation of net thrust power, condenser weight and frontal area, and specific condenser weight and frontal area with $\Delta p/q$ is shown in figure 4 (a cross-plot of fig. 3) for turbine-inlet pressures of 1000, 1400, and 1800 pounds per square inch absolute and a turbine-outlet pressure of 100 pounds per square inch absolute.

The condenser weight and frontal area decrease with increasing $\Delta p/q$ inasmuch as the required area is less at the higher pressure drops. The net thrust horsepower also decreases with increasing $\Delta p/q$ due to the increase in internal drag power.

The specific condenser weight and frontal area have minimum values at a $\Delta p/q$ of about 0.30 at all turbine-inlet pressures for the flight speed and altitude shown. The values of $\Delta p/q$ corresponding to minimum values of specific condenser weight and frontal area vary somewhat with flight speed and altitude, as will be seen in a subsequent figure.

Effect of turbine-inlet temperature on condenser performance. - The variation of net thrust power, condenser weight and frontal area, and specific condenser weight and frontal area with turbine-inlet temperature is shown in figure 5. The curves are for a turbine-inlet pressure of 1400 pounds per square inch absolute, a turbine-outlet pressure of 100 pounds per square inch absolute, a $\Delta p/q$ of 0.30, and a turbine horsepower of 1000. A line a-b is drawn through a temperature of 866° F, the turbine-inlet temperature that will give saturated steam (100-percent quality) at the turbine outlet for the turbine-inlet and turbine-outlet pressures considered. Any temperature above 866° F will result in superheated steam at the turbine outlet.

Superheating to turbine-inlet temperatures higher than those required to give saturated steam at the turbine outlet results in an increase in steam-cycle efficiency and in work available per pound of steam with the result that for constant turbine horsepower the steam flow is decreased. Although the heat rejected by the condenser per pound of steam increases, the total heat that must be removed by the condenser is decreased. Also, the higher turbine-outlet (condenser-inlet) steam temperature increases the initial temperature difference between the steam and the cooling air. The reduced heat rejection and the higher initial temperature difference act to decrease the condenser frontal area and weight. The foregoing effects are offset to some extent by the fact that the heat-transfer coefficient for cooling superheated steam is considerably smaller than for condensing steam with the result that

the surface area and, hence, frontal area required for cooling the steam is proportionately larger. A reduction in specific condenser weight and frontal area of about 8 percent is obtained by increasing the turbine-inlet temperature from 866° to 1600° F.

These results were obtained assuming the same exchanger core structure to be used for the cooling as for the condensing process. A somewhat greater reduction in specific condenser frontal area and a slightly greater reduction in specific condenser weight with increasing turbine-inlet temperature may possibly be obtained by using an exchanger specifically designed for the steam-cooling process.

Effect of flight speed and altitude on condenser performance. -

The effect of flight speed on net thrust horsepower, specific condenser weight, and specific condenser frontal area for various condenser weights and frontal areas at altitudes of sea-level, 15,000, and 30,000 feet is shown in figure 6. The turbine-inlet pressure is 1400 pounds per square inch absolute, the turbine-outlet pressure is 100 pounds per square inch absolute, the turbine-inlet temperature is 866° F, and the turbine horsepower is 1000. Also shown on these curves are lines of constant $\Delta p/q$. The lines of required pressure drop equal to maximum available pressure drop mark the limiting flight speeds below which the condensers will not dissipate the required amount of heat.

In general, for constant altitude and condenser weight and frontal area, the net thrust power increases and the specific condenser weight and frontal area decrease with increasing flight speed. The effect of flight speed decreases as the altitude decreases and at sea level the curves for net thrust power and specific weight and frontal area are relatively insensitive to changes in flight speed. The highest net thrust powers are obtained with the largest condensers at all altitudes because the required pressure drops and, hence, the internal drag power losses are less. The condenser weight and frontal area for minimum specific weight and frontal area increases slightly with increasing altitude; however, the 13.0-square-foot condenser is approximately the optimum, on the basis of specific weight, for the range of altitudes and flight speeds investigated. The curve for the 9.7-square-foot condenser was omitted from figure 6(c) (altitude, 30,000 ft) because of the extremely high specific condenser weight and specific frontal area.

Figure 6 shows, as previously mentioned, that the values of $\Delta p/q$ corresponding to minimum values of specific condenser weight and frontal area vary with flight speed and altitude. For constant

altitude, the value of $\Delta p/q$ corresponding to minimum specific condenser weight and frontal area tends to increase as flight speed is decreased. Comparison of figures 6(a), 6(b), and 6(c) shows that for constant flight speed the value of $\Delta p/q$ for minimum specific weight and area increases as the altitude is increased.

The variation of net thrust horsepower with flight speed and altitude for the condenser weighing 200 pounds and having a frontal area of 13.0 square feet is shown as a three-dimensional plot in figure 7. The line a-b indicates the combinations of altitude and flight speed for which the required pressure drop equals the maximum available pressure drop. At sea level, the minimum speed is about 185 miles per hour; the power plant would therefore have to be operated partly noncondensing in take-off until this minimum speed is reached.

The maximum point on the surface c-d-e-f indicates the speed and altitude at which maximum net thrust power and hence, minimum specific weight and minimum specific frontal area occur. A minimum specific weight of 257 pounds and a minimum specific frontal area of 16.7 square feet occur at an altitude of about 15,000 feet and a flight speed of 500 miles per hour. This frontal area is large compared to that required for a radiator for a conventional liquid-cooled aircraft engine (about 1.5 sq ft/1000 hp).

Effect of cooling fan on condenser performance. - The effect of a cooling fan on condenser performance is shown in figure 8 where net thrust horsepower, specific condenser weight, and specific condenser frontal area are plotted against $\Delta P_f/q$ (ratio of total pressure rise across the fan to compressible dynamic pressure at the assumed altitude and speed) for various condenser weights and frontal areas at a flight speed of 500 miles per hour and an altitude of 30,000 feet. The line $\Delta P_f/q = 0$ represents the case where no fan is used.

For each of the condensers considered, the net thrust power has a maximum value and the specific condenser weight and area have minimum values when $\Delta P_f/q$ is between 0.5 and 1.0. The curves indicate only a small improvement in performance by the addition of a fan except for the 9.7-square-foot condenser. Although the improvement in performance of this condenser is large, its best performance is considerably poorer than the larger condensers with no fan.

The effect of a fan on condenser performance is shown in figure 9 for a 19.5-square-foot condenser at three altitudes at a flight speed of 500 miles per hour and at an altitude of 30,000 feet and a flight speed of 300 miles per hour. Figure 9 shows that the improvements in performance obtainable with a cooling fan are even smaller at the lower altitudes and only slightly greater at the lower flight speed.

The maximum decrease in specific weight and specific frontal area of the condenser with the most effective size (13.0 sq ft) that can be obtained by use of a fan is about 11 percent. (See fig. 8.) In view of the small gains in condenser performance, the additional weight of the fan, and the complexities of the installation, a fan is probably undesirable for this type of system.

Effect of turbine-outlet pressure on over-all efficiency. - The variation of over-all efficiency, defined as the dimensionless ratio of net thrust power minus nacelle drag power to reactor-heat input, is probably of greater importance than the previously discussed variation of specific condenser weight and frontal area. If the reactor weight is the principal consideration, then with the reactor operating at its maximum heat-release rate, maximum net thrust power per unit weight of the system will be obtained at maximum over-all efficiency.

The effect of turbine-outlet pressure on over-all efficiency is shown in figure 10 for various turbine-inlet pressures and values of $\Delta p/q$. The over-all efficiency decreases with increasing outlet pressure except at high values of $\Delta p/q$, where it has a maximum at outlet pressures between 40 and 80 pounds per square inch absolute. As previously mentioned, the most effective operating outlet pressure from considerations of specific condenser weight and frontal area is between approximately 30 and 100 pounds per square inch absolute. (See fig. 3.) The curves of over-all efficiency and specific condenser weight and frontal area at values of $\Delta p/q$ of 0.20 and 0.40 are relatively flat in this region of turbine-outlet pressure; hence, it appears that the most desirable operating conditions from considerations of optimum utilization of the reactor may occur close to the optimum operating conditions for the condenser.

Because of the relative effects of condenser internal and external drag, the over-all efficiency (at constant values of turbine-inlet and turbine-outlet conditions) passes through a maximum at some value of $\Delta p/q$, which depends on flight speed

~~CONFIDENTIAL~~

and altitude. For the flight conditions shown, the maximum values of over-all efficiency occur at a value of $\Delta p/q$ of about 0.20 for all turbine-inlet and turbine-outlet pressures.

Power-plant-weight estimates. - Weight estimates indicate that for a turbine operating at an inlet pressure of 1400 pounds per square inch absolute, an outlet pressure of 100 pounds per square inch absolute, an inlet temperature of 866° F, and a power output of 5000 horsepower the total power-plant weight including propeller but excluding reactor and working fluid would be 5460 pounds at a flight speed of 500 miles per hour and an altitude of 30,000 feet. (See the appendix for a discussion of the weight breakdown.) This weight would correspond to specific weights of 1.09 pounds per turbine horsepower, 1.59 pounds per net thrust horsepower with the condenser submerged in the wings (no external nacelle drag), and 2.55 pounds per net thrust horsepower with the condenser in a nacelle. At a flight speed of 300 miles per hour and an altitude of 15,000 feet, the power-plant weight would be 5870 pounds (owing to a heavier propeller) and the corresponding specific weights would be 1.17, 1.74, and 1.97 pounds per horsepower, respectively.

For the condenser enclosed in a nacelle, the ratio of disposable load to gross weight of the airplane would be 0.41 for a flight speed of 500 miles per hour and an altitude of 30,000 feet. If the condenser could be so installed in the wings as to eliminate external drag, this value could be raised to 0.48. In other words, a weight-carrying capacity equal to 41 to 48 percent of the gross weight of the airplane would be available for a nuclear reactor, working fluid, and cargo; or conversely, the gross weight of an airplane with a nuclear-energy steam-turbine power plant would be about 2 to $2\frac{1}{2}$ times the weight of the reactor, working fluid, and cargo.

For the same condenser and operating conditions but at a flight speed of 300 miles per hour and an altitude of 15,000 feet, the values of the ratio of disposable load to gross weight for the cases of the condenser in a nacelle and the condenser submerged would be 0.51 and 0.52, respectively.

SUMMARY OF RESULTS

The results of calculations of the performance of condensers for a nuclear-energy steam-turbine power plant for aircraft may be summarized as follows:

838

1. Minimum specific condenser weights and specific frontal areas occurred at turbine-outlet pressures between approximately 30 and 100 pounds per square inch absolute for inlet pressures of 1000, 1400, and 1800 pounds per square inch absolute and cooling-air pressure drops of 20 to 60 percent of the compressible dynamic pressure.

2. At a turbine-inlet pressure of 1400 pounds per square inch absolute and a turbine-inlet temperature of 866° F, the minimum specific condenser weight was 257 pounds per 1000 net thrust horsepower and the minimum specific condenser frontal area was 16.7 square feet per 1000 net thrust horsepower. These values occurred at a turbine-outlet pressure of 100 pounds per square inch absolute, a flight speed of 500 miles per hour, and an altitude of about 15,000 feet.

3. Relatively small improvement in condenser performance can be obtained by increasing the turbine-inlet temperature above that required to give saturated steam at the turbine outlet.

4. A decrease in specific condenser weight and frontal area of about 11 percent may be obtained at an altitude of 30,000 feet and an airplane velocity of 500 miles per hour by placing a cooling fan ahead of the condenser. The greatest gains in performance with a fan were obtained at the highest altitude investigated. In view of the additional weight of the fan and the installation complexities, the improvements in performance obtained by use of the fan are probably insignificant.

5. A weight estimate based on a turbine output of 5000 horsepower at a flight speed of 500 miles per hour and an altitude of 30,000 feet indicated that the specific weights of the installed power plant excluding the reactor would be 1.09 pounds per turbine horsepower, 1.59 pounds per net thrust horsepower with condenser submerged in the wings (no external condenser drag), and 2.55 pounds per net thrust horsepower with condenser enclosed in a nacelle. Calculations based on this weight estimate indicate that a weight-carrying capacity equal to 41 percent (condenser in nacelle) to 48 percent (condenser in wing) of the gross weight of a steam-turbine-powered aircraft would be available for carrying the nuclear reactor and cargo.

Flight Propulsion Research Laboratory,
National Advisory Committee for Aeronautics,
Cleveland, Ohio.

SECRET

APPENDIX - DETAILS OF METHOD OF CALCULATION

Steam-cycle calculations. - The cycle is shown on enthalpy-entropy ($H - S$) coordinates in figure 11. A pump raises the water pressure from the turbine-outlet pressure P_o to the turbine-inlet pressure P_1 along line a-b in figure 11. The water is warmed, evaporated, and superheated in the boiler along line b-c to the turbine-inlet temperature (point c). Steam at the conditions represented by point c enters the turbine and expands to saturation at the turbine-outlet pressure (point d). A condenser removes the latent heat of the steam and discharges it as saturated liquid at point a. Pressure drops of the working fluid through the boiler and the condenser were neglected. The enthalpy (and superheat) at point c was determined by trial and error and had a value such that

$$\frac{H_c - H_d}{H_c - H_d'} = 0.85 \quad (1)$$

where the subscripts refer to points on figure 11. That is, the adiabatic efficiency of the turbine was 85 percent. The pumping work per pound of steam was taken as $(P_1 - P_o)v$ (where v is the specific volume of the saturated liquid at P_o).

For all calculations, the steam rate was adjusted to give 1000 shaft horsepower after the deduction of pumping power. The required steam rate W_s in pounds per second for 1000 net shaft horsepower was therefore obtained from the following relation:

$$\left[778 (H_c - H_d) - (P_1 - P_o) v \right] \frac{W_s}{550} = 1000 \quad (2)$$

where $(H_c - H_d)$ is in Btu per pound, $(P_1 - P_o)$ is in pounds per square foot, and v is in cubic feet per pound.

The reactor-heat input Q_r (Btu/sec), the heat rejected to the condenser Q_c (Btu/sec), and the cycle efficiency η_c were obtained by the following relations:

$$Q_r = W_s \left[(H_c - H_a) - (P_1 - P_o) \frac{v}{778} \right] \quad (3)$$

$$Q_c = W_s (H_d - H_a) \quad (4)$$

$$\eta_c = \frac{(H_c - H_d) - (P_1 - P_o) \frac{v}{778}}{(H_c - H_a) - (P_1 - P_o) \frac{v}{778}} \quad (5)$$

The properties of the steam for these calculations were obtained from reference 1.

838

Condenser cooling-air pressure drop. - Charts of heat dissipation and cooling-air static-pressure drop against cooling-air flow for the condenser were supplied by the heat-exchanger manufacturer. The investigations from which the data for these curves were obtained were made at sea-level entrance conditions of cooling-air pressure and temperature and with an initial temperature difference ΔT_i between the condensing steam and cooling air of approximately 100° F. The heat dissipations given by the charts are valid for all entrance conditions and initial temperature differences. The variation of heat dissipation in Btu per minute per 100° F of initial temperature difference with cooling-air flow in pounds per minute is shown in figure 12 for a condenser having a frontal area of 1 square foot. The pressure drop required for a given flow of cooling air, however, may vary considerably with altitude, flight speed, and initial temperature difference making it necessary to modify the experimental curve in order to account for the effect of these variables.

The experimental curves were modified by calculating values of the cooling-air static-pressure drop across the condenser $\sigma \Delta p$ (product of the ratio σ of cooling-air entrance density to NACA standard sea-level density and the static-pressure drop Δp) for various altitudes and heat loadings. The quantity $\sigma \Delta p$ was taken as the sum of: (1) entrance loss; (2) velocity-profile loss; (3) vena-contracta loss; (4) friction loss; (5) heat-exchange or momentum loss; and (6) exit loss. Density changes at the entrance and exit sections were assumed to be negligible and an average density was used to calculate the friction loss. With the assumption that the air-flow passages between the elongated tubes and fins were rectangular channels (fig. 1) having an effective diameter equal to four times the cross-sectional area divided by the perimeter, the variation of friction factor with Reynolds number was calculated using the cooling-air pressure drops and corresponding air flows from the manufacturer's experimental sea-level curves. These friction factors together with velocity and density changes of the cooling air in the condenser resulting from variation in altitude and heat loading were then used to calculate the corresponding pressure drops. The calculations were limited to turbulent flow (approximate range of Reynolds number, 2000 to 20,000) and to Mach numbers in the condenser of less than 0.5.

The variation of σAp with cooling-air flow is shown in figure 13. Curve A is the manufacturer's experimental curve for sea-level entrance conditions and an initial temperature difference of 100° F. Curves B, C, D, and E are representative calculated curves for an altitude of 30,000 feet, a flight speed of 500 miles per hour, and initial temperature differences of 100° , 200° , 300° , and 400° F, respectively.

Condenser weight, frontal area, and internal drag. - A schematic diagram of the condenser enclosed in a nacelle is shown in figure 14(a). Army standard air was assumed at station 0 ahead of the nacelle. The total temperature at the face of the condenser, station 1, was calculated from the expression

$$T_1 = t_0 + \frac{V_0^2}{2gJc_p} \quad (6)$$

where

T_1 total temperature at condenser face, $^\circ R$

t_0 ambient-air temperature, $^\circ R$

V_0 flight speed, ft/sec

g acceleration due to gravity, 32.2 ft/sec^2

J mechanical equivalent of heat, 778 ft-lb/Btu

c_p specific heat of air at constant pressure, $\text{Btu}/(\text{lb})(^\circ F)$

The static pressure at the face of the condenser was taken as

$$P_1 = P_0 \left\{ \left[\left(1 + \frac{V_0^2 - V_1^2}{2gJc_p t_0} \right)^{\frac{\gamma}{\gamma-1}} - 1 \right] \epsilon_r + 1 \right\} \quad (7)$$

where

P_1 static pressure at condenser face, in. Hg absolute

P_0 ambient-air pressure, in. Hg absolute

V_1 velocity at condenser face, ft/sec

γ ratio of specific heats of air

ϵ_r diffuser pressure-rise recovery factor, (assumed to be 0.90)

The initial temperature difference ΔT_1 between the steam and the cooling air was taken as $T_g - T_1$, where T_g is the temperature of the steam in the condenser.

The relation between condenser frontal area, heat dissipation rate, initial temperature difference, and heat removed from the steam by the condenser is given by the following expression:

$$A = \frac{60 \times 100 Q_c}{H_r \Delta T_1} \quad (8)$$

where

A condenser frontal area, sq ft

Q_c heat removed from steam by condenser, Btu/sec

H_r heat-dissipation rate, (Btu)/(min)(100° F ΔT_1)(sq ft frontal area)

The quantity H_r is a function of the cooling-air flow (fig. 12), which is a function of the pressure drop (fig. 13); hence, for given values of Q_c , ΔT_1 , and static-pressure drop Δp , a value of H_r and therefore a condenser frontal area may be determined. Also, if the condenser frontal area A is known and Q_c and ΔT_1 are given, a value of H_r can be calculated from equation (8) and the required cooling-air flow and pressure drop determined from figures 12 and 13. Inasmuch as the air flow given in figures 12 and 13 is for a 1-square-foot section, the air flow as obtained from these figures must be multiplied by the total frontal area in order to obtain a total weight flow of cooling air.

The temperature rise of the cooling air in passing through the condenser ΔT_c and the total temperature T_2 at the condenser exit (station 2, fig. 14(a)) are given by

$$T_2 = T_1 + \Delta T_c = T_1 + \frac{Q_c}{W c_p} \quad (9)$$

where W is the cooling-air flow in pounds per second. The corresponding static temperature t_2 is given by

$$t_2 = T_2 - \frac{V_2^2}{2gJc_p} \quad (10)$$

where V_2 , the velocity of the cooling air at station 2, is obtained from the continuity equation. Thus

$$V_2 = \frac{WR t_2}{p_2 A} \quad (11)$$

where

R gas constant for air, ft-lb/(lb)(°F)

p_2 condenser-outlet static pressure, lb/sq ft absolute

The pressure p_2 was taken as the static pressure at station 1 minus the cooling-air static-pressure drop. The assumption is made in equation (11) that the cross-sectional area at station 2 is the same as the condenser frontal area. Equations (10) and (11) can be combined to give a quadratic equation for t_2 in terms of the known quantities T_2 , p_2 , W , and A . The velocity at the exit (station 3) is then

$$V_3 = C \sqrt{2gJc_p t_2 \left[1 - \left(\frac{p_0}{p_2} \right)^{\frac{\gamma-1}{\gamma}} \right] + v_2^2} \quad (12)$$

where C is an over-all velocity coefficient having an assumed value of 0.96 and the pressures are in inches of mercury absolute.

In the present study, negligible error was introduced by substituting T_2 for t_2 in equations (11) and (12) in order to simplify the computations.

The internal drag horsepower hp_d is

$$hp_d = \frac{WV_0 (V_0 - V_3)}{550 g} \quad (13)$$

The effect of a change in internal drag power is represented through its effect on the net thrust horsepower hp_n , which is defined as

$$hp_n = \eta_p hp_t - hp_d \quad (14)$$

where

hp_t turbine-shaft power (constant at 1000 hp)

η_p propeller efficiency (constant at 0.85)

Effect of turbine-inlet temperature. - In these calculations turbine-inlet temperatures above those required to give saturated steam at the turbine outlet were investigated. The cycle is represented in figure 11 by the path a-b-e-f-a. For this case the condenser must cool steam from point f to point d in addition to the condensing process from point d to point a. Inasmuch as the over-all heat-transfer coefficient for cooling superheated steam is considerably lower than for condensing steam, the heat-dissipation curve (fig. 12) could not be used to determine the total required frontal area. The size of the heat exchanger required to condense the steam was determined by the method previously outlined and an over-all heat-transfer coefficient based on the effective-air-side surface area was calculated and used to determine the additional area required to cool the steam from point f to point d (fig. 11).

Calculation of the over-all heat-transfer coefficient U_2 for cooling superheated steam involved several steps. The over-all heat-transfer coefficient for condensing steam U_1 was first determined from figure 12. The film coefficient on the steam side $h_{s,1}$ was then calculated from equation (19), reference 2 (p. 269), for film-type condensation on vertical surfaces. When the resistance of the tube wall to heat flow is assumed to be negligible, the air-side film coefficient h_a may then be calculated from the relation

$$\frac{1}{U_1} = \frac{1}{rh_{s,1}} + \frac{1}{h_a} \quad (15)$$

where r is the ratio of steam-side surface area to effective-air-side surface area. A steam-side film coefficient for cooling steam $h_{s,2}$ was then determined by the method given in reference 3 and was used in conjunction with h_a from equation (15) in order to calculate the over-all heat-transfer coefficient for cooling steam U_2 :

$$\frac{1}{U_2} = \frac{1}{rh_{s,2}} + \frac{1}{h_a} \quad (16)$$

The remainder of the calculation for internal drag power and net thrust power was the same as that outlined for the straight condensing case.

Condenser and cooling fan. - For these calculations, the fan was assumed to be mounted at the face of the condenser, as shown in figure 14(b). The total-temperature rise across the fan ΔT_f was calculated from the expression

$$\Delta T_f = \frac{T_1}{\eta_f} \left[\left(\frac{P_{1,a}}{P_1} \right)^{\frac{\gamma-1}{\gamma}} - 1 \right] \quad (17)$$

where

T_1 total temperature immediately ahead of fan, °R (calculated from equation (6))

η_f adiabatic fan efficiency (assumed to be 0.85)

P_1 total pressure immediately ahead of fan, in. Hg absolute

$P_{1,a}$ total pressure at condenser face, in. Hg absolute

Calculations were made for a range of values of $\Delta P_f/q$ (ratio of fan total-pressure rise to free-stream compressible dynamic pressure). The horsepower required to drive the fan hp_f was calculated from the expression

$$hp_f = \frac{W J c_p}{550} \Delta T_f \quad (18)$$

The internal drag power was calculated from equation (13).

The turbine and fan were assumed to be on the same shaft and the turbine power in excess of that required to drive the fan was assumed to be transmitted to the propeller. The expression for net thrust horsepower then becomes

$$hp_n = \eta_p (hp_t - hp_f) - hp_d \quad (19)$$

Power-plant weight estimate. - Preliminary design calculations were made for a steam turbine delivering 5000 shaft horsepower at an inlet pressure of 1400 pounds per square inch absolute, an inlet temperature of 866° F, and an outlet pressure of 100 pounds per square inch absolute. From the pitch diameters and the number of rotor disks, an estimate was made of rotor and stator weights by assuming that these weights varied as the square of the diameter

and using the weight and pitch diameter of a current aircraft rotor and stator as a standard. Based on stress considerations, the total turbine weight was then increased to allow for the heavy casing required at the high operating pressure.

A condenser with a frontal area of 13 square feet and a weight of 200 pounds, the performance of which is shown in figure 6, was used for this weight estimate. Inasmuch as all previous calculations, including those made for figure 6, were based on 1000 horsepower from the steam turbine, it was necessary to multiply this weight of 200 pounds by 5 to obtain the proper value for a power output of 5000 turbine horsepower.

A boiler feed-pump weight of 200 pounds was considered to be sufficiently high, inasmuch as aircraft-type fuel pumps of the required capacity operating at pressures up to 500 to 600 pounds per square inch and weighing about 50 pounds are now available.

The weight of gearing between the turbine and the propeller was assumed to be 0.2 pound per shaft horsepower, a value consistent with reduction-gear weights of present turbine-propeller engines.

The propeller weight is a scaled value based on the assumption that the weight varies with shaft power, altitude, and flight speed and using the weight and power absorption of a typical aircraft propeller as a base.

A breakdown of the engine weight W_e in pounds (exclusive of reactor and working fluid) is as follows:

Turbine	1000
Condenser core	1000
Propeller (500 mph, 30,000 ft)	1360
Boiler feed pump	200
Piping, valves, fittings, etc.	400
Reducing gearing	1000
Air ducting	200
Engine mountings*	200
Controls	100
Total weight	5460

The gross weight W_g of the airplane in pounds was calculated from the expression

$$W_g = \frac{550}{V_0} \frac{L}{D} (\eta_p hp_t - hp_d - hp_{nac}) \quad (20)$$

where

L/D lift-drag ratio of airplane without nacelles (assumed to be 18)

hp_{nac} external drag power of nacelle, hp

V_0 flight speed, ft/sec

The external drag power of the nacelle was calculated as follows:

$$hp_{nac} = \frac{C_D}{1100 \text{ g}} \rho_0 V_0^3 A_{nac} \quad (21)$$

where

C_D nacelle drag coefficient (assumed to be 0.0657 at 500 mph and 30,000 ft)

ρ_0 density of ambient air, lb/cu ft

A_{nac} nacelle frontal area, sq ft (assumed to be 1.05 x condenser frontal area)

The disposable load W_d available for nuclear reactor, working fluid, and cargo was then

$$W_d = W_g - W_{st} - W_e \quad (22)$$

where

W_{st} structure weight, lb (assumed to be 40 percent of gross weight)

W_e power-plant weight, lb

The following sample calculations of the quantity W_d/W_g and specific power-plant weights are given for a flight speed of 500 miles per hour and an altitude of 30,000 feet: The condenser frontal area is 13×5 (65) square feet and the corresponding net thrust power ($\eta_p hp_t - hp_d$) from figure 6(c) is 688×5 (3440) horsepower for 5000 turbine horsepower.

$$A_{nac} = 1.05 \times 65 = 68.25 \text{ sq ft}$$

$$hp_{nac} = \frac{0.0657}{1100 \times 32.2} \times 0.02606 \times 733^3 \times 68.25 = 1300 \text{ hp}$$

$$hp_n - hp_{nac} = 3440 - 1300 = 2140 \text{ hp}$$

$$W_g = 18 \times 2140 \times \frac{550}{733} = 28,900 \text{ lb}$$

$$W_{st} = 0.4 \times 28,900 = 11,560 \text{ lb}$$

$$W_d = 28,900 - 11,560 - 5460 = 11,880 \text{ lb}$$

$$\frac{W_d}{W_g} = \frac{11,880}{28,900} = 0.41$$

For the case with the condenser submerged in the wing ($hp_{nac} = 0$), W_d/W_g is found to be 0.48.

Specific weights of the power plant on the bases of (a) turbine power, (b) net thrust power, and (c) net thrust power minus nacelle drag power are:

$$(a) \text{ pounds per turbine horsepower} = \frac{5460}{5000} = 1.09$$

$$(b) \text{ pounds per net thrust horsepower} = \frac{5460}{3440} = 1.59$$

$$(c) \text{ pounds per net thrust horsepower minus nacelle drag horsepower} = \frac{5460}{2140} = 2.55$$

At a flight speed of 300 miles per hour and an altitude of 15,000 feet, the propeller weight is 1770 pounds and the corresponding power-plant weight is 5870 pounds. The values of W_d/W_g for these flight conditions are 0.51 with the condenser in a nacelle and 0.52 with the condenser submerged in the wing.

The specific weights at 300 miles per hour and 15,000 feet based on turbine power, net thrust power, and net thrust power minus nacelle drag power are 1.17, 1.74, and 1.97 pounds per horsepower, respectively.

REFERENCES

1. Keenan, Joseph H., and Keyes, Frederick G.: Thermodynamic Properties of Steam. John Wiley & Sons, Inc., 1936.
2. McAdams, William H.: Heat Transmission. McGraw-Hill Book Co., Inc., 2d ed., 1942.
3. Norris, R. H., and Streid, D. D.: Laminar-Flow Heat-Transfer Coefficients for Ducts. Am. Soc. Mech. Engrs. Trans., vol. 62, no. 6, Aug. 1940, pp. 525-533.

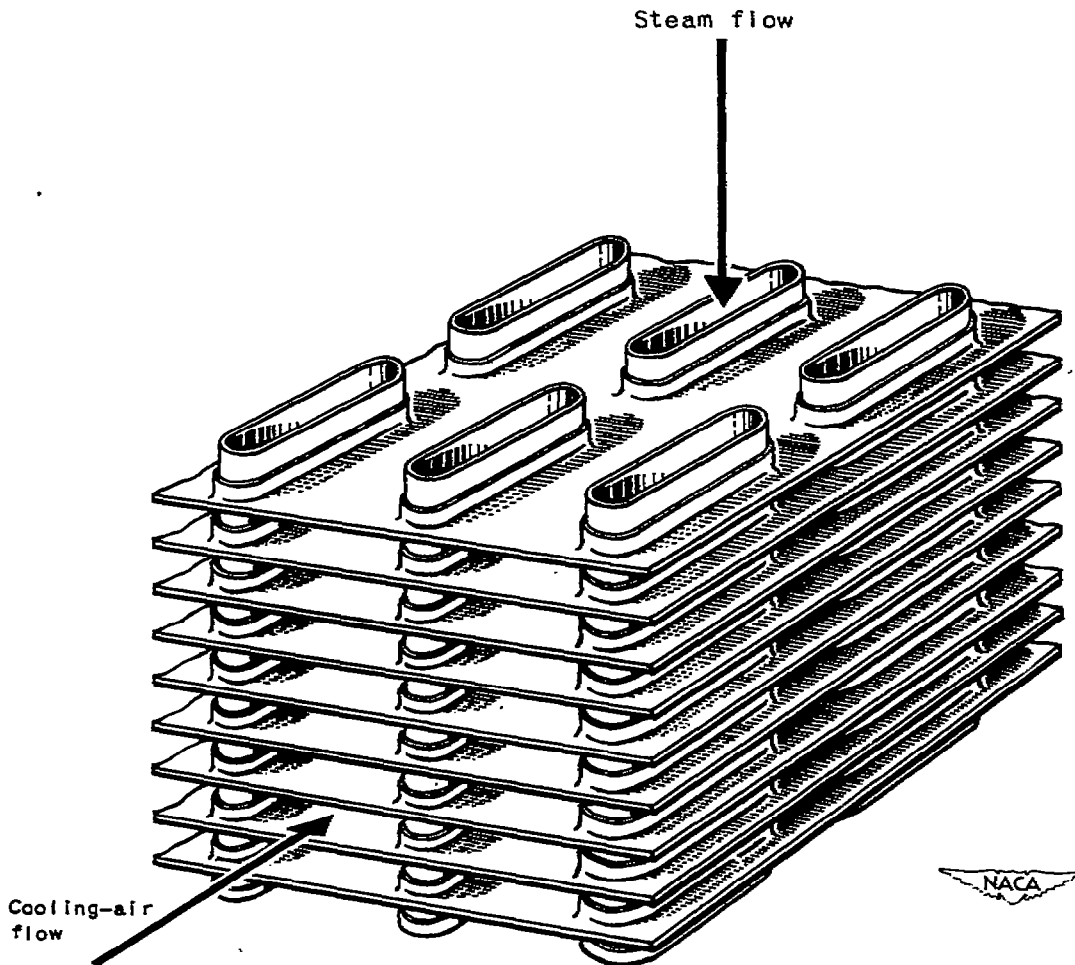

Dimensions of a 1-square-foot section

Length (steam-flow direction), in.	12
Width (no-flow direction), in.	12
Depth (cooling-air-flow direction), in.	8.75
Fins per in.	11
Outside tube dimensions, in.	1.215 x 0.084
Tube rows (cooling-air-flow direction)	6
Distance between tube center lines (no-flow direction), in.	0.406

Figure 1. - Schematic diagram of condenser-core structure.

~~CONFIDENTIAL~~

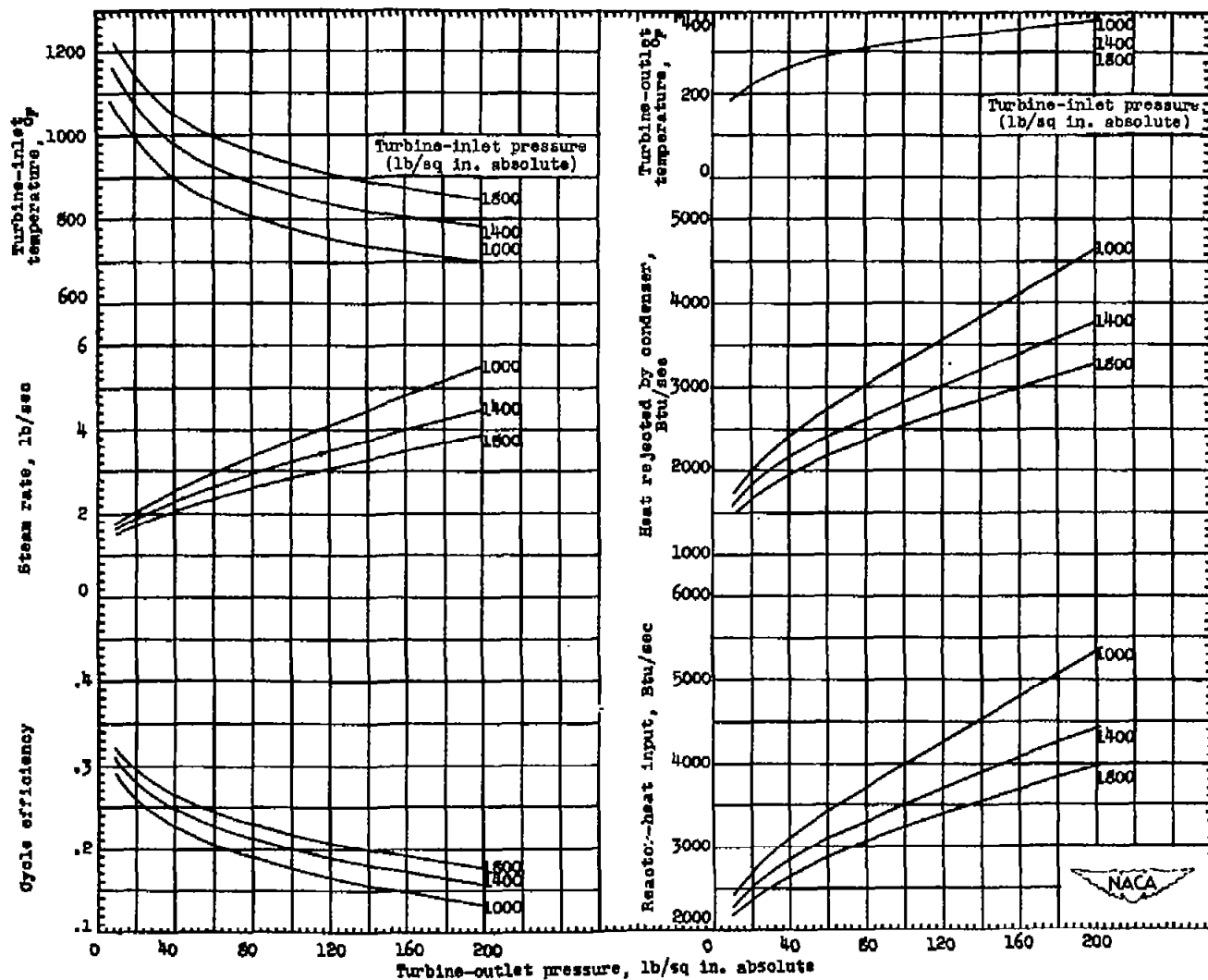

Figure 2. - Variation of cycle efficiency, steam rate, turbine-inlet temperature, reactor-heat input, heat rejected by condenser, and turbine-outlet temperature with turbine-outlet pressure for three turbine-inlet pressures. Turbine power, 1000 horsepower; turbine efficiency, 0.85; saturated steam at turbine outlet.

838

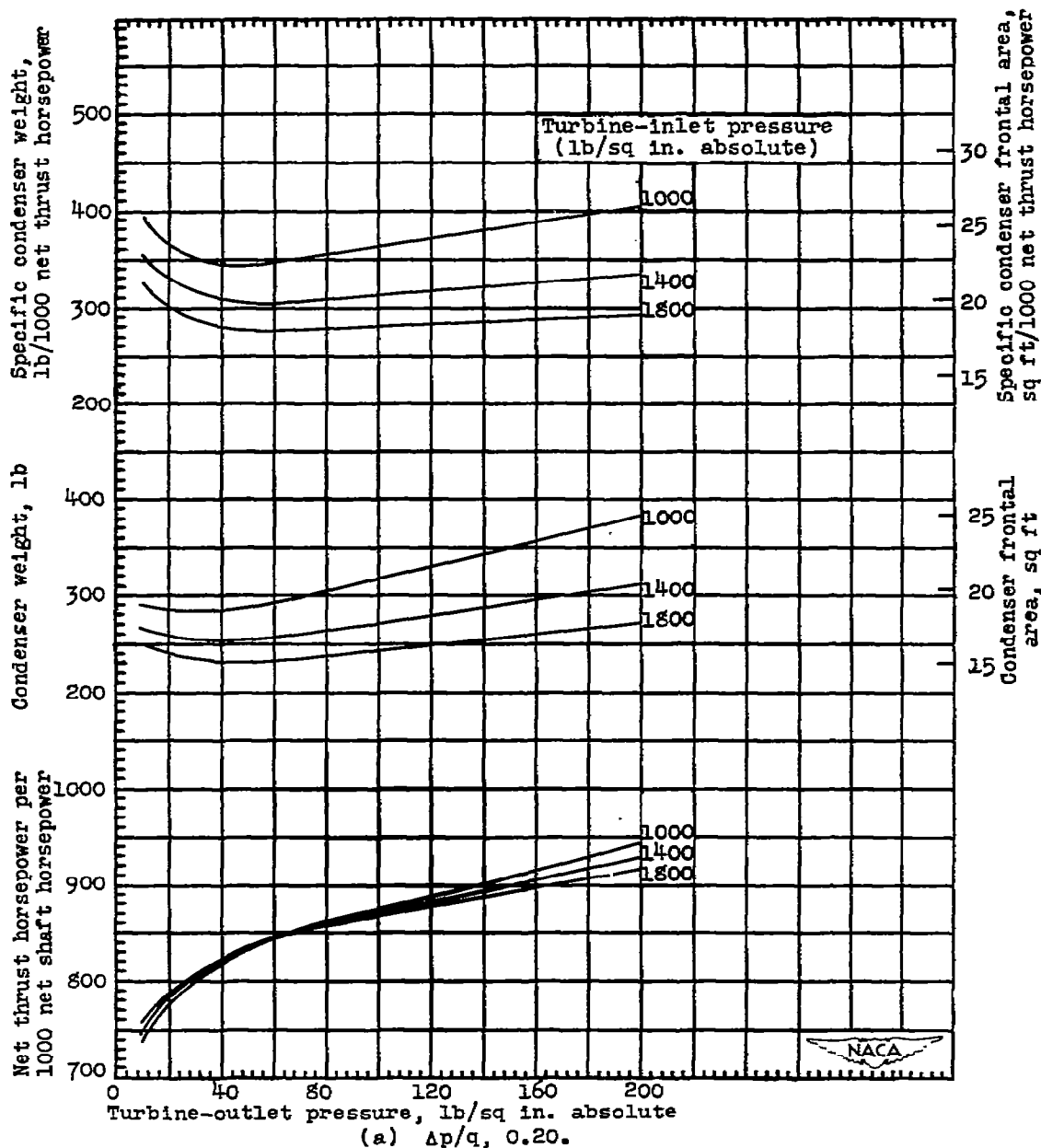

Figure 3. - Variation of net thrust horsepower, condenser weight and frontal area, and specific condenser weight and frontal area with turbine-outlet pressure for three turbine-inlet pressures. Flight speed, 500 miles per hour; altitude, 30,000 feet; turbine power, 1000 horsepower; turbine and propeller efficiencies, 0.85; saturated steam at turbine outlet.

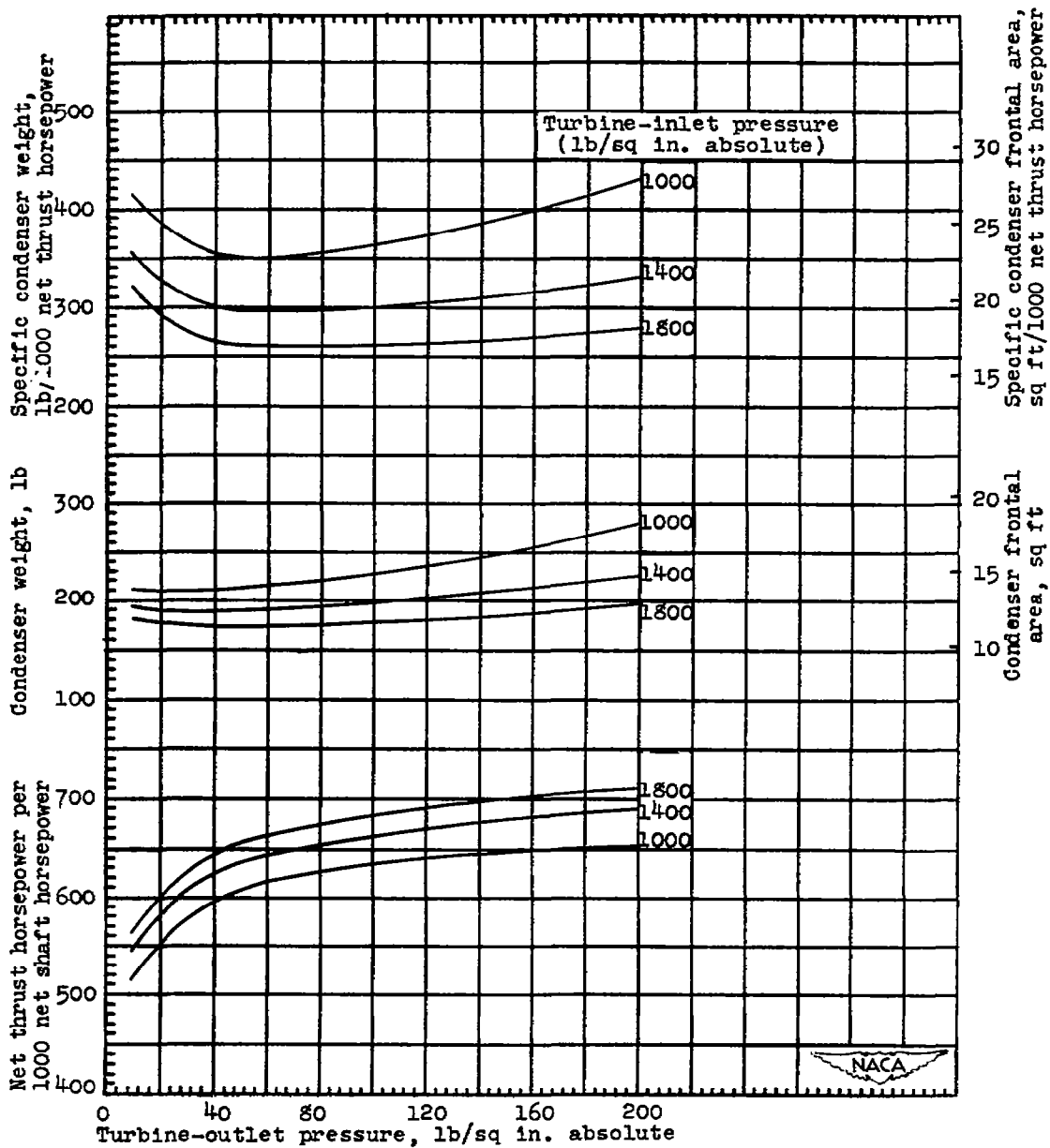

Figure 3. - Continued. Variation of net thrust horsepower, condenser weight and frontal area, and specific condenser weight and frontal area with turbine-outlet pressure for three turbine-inlet pressures. Flight speed, 500 miles per hour; altitude, 30,000 feet; turbine power, 1000 horsepower; turbine and propeller efficiencies, 0.85; saturated steam at turbine outlet.

838

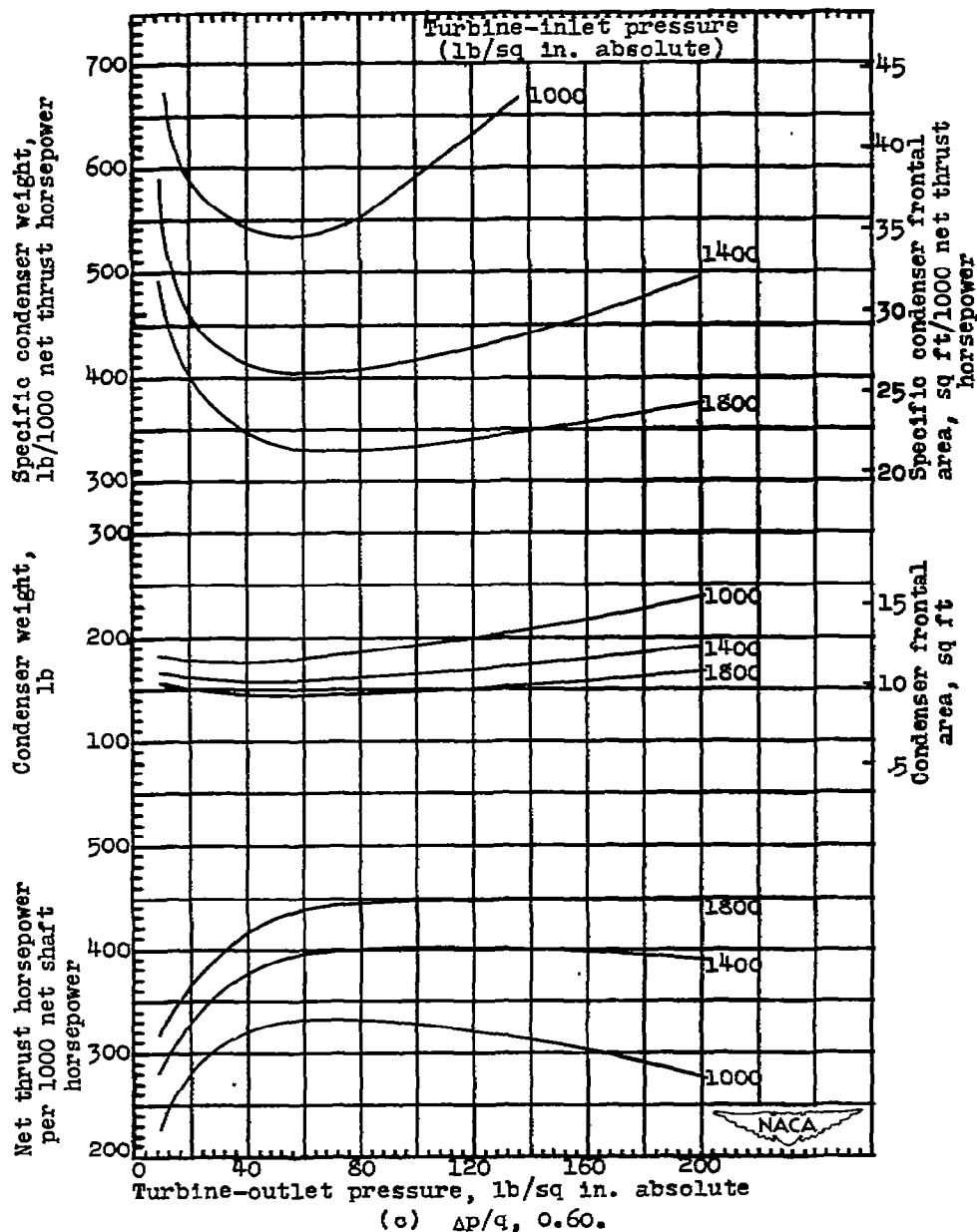

Figure 3. - Concluded. Variation of net thrust horsepower, condenser weight and frontal area, and specific condenser weight and frontal area with turbine-outlet pressure for three turbine-inlet pressures. Flight speed, 500 miles per hour; altitude, 30,000 feet; turbine power, 1000 horsepower; turbine and propeller efficiencies, 0.85; saturated steam at turbine outlet.

CONFIDENTIAL

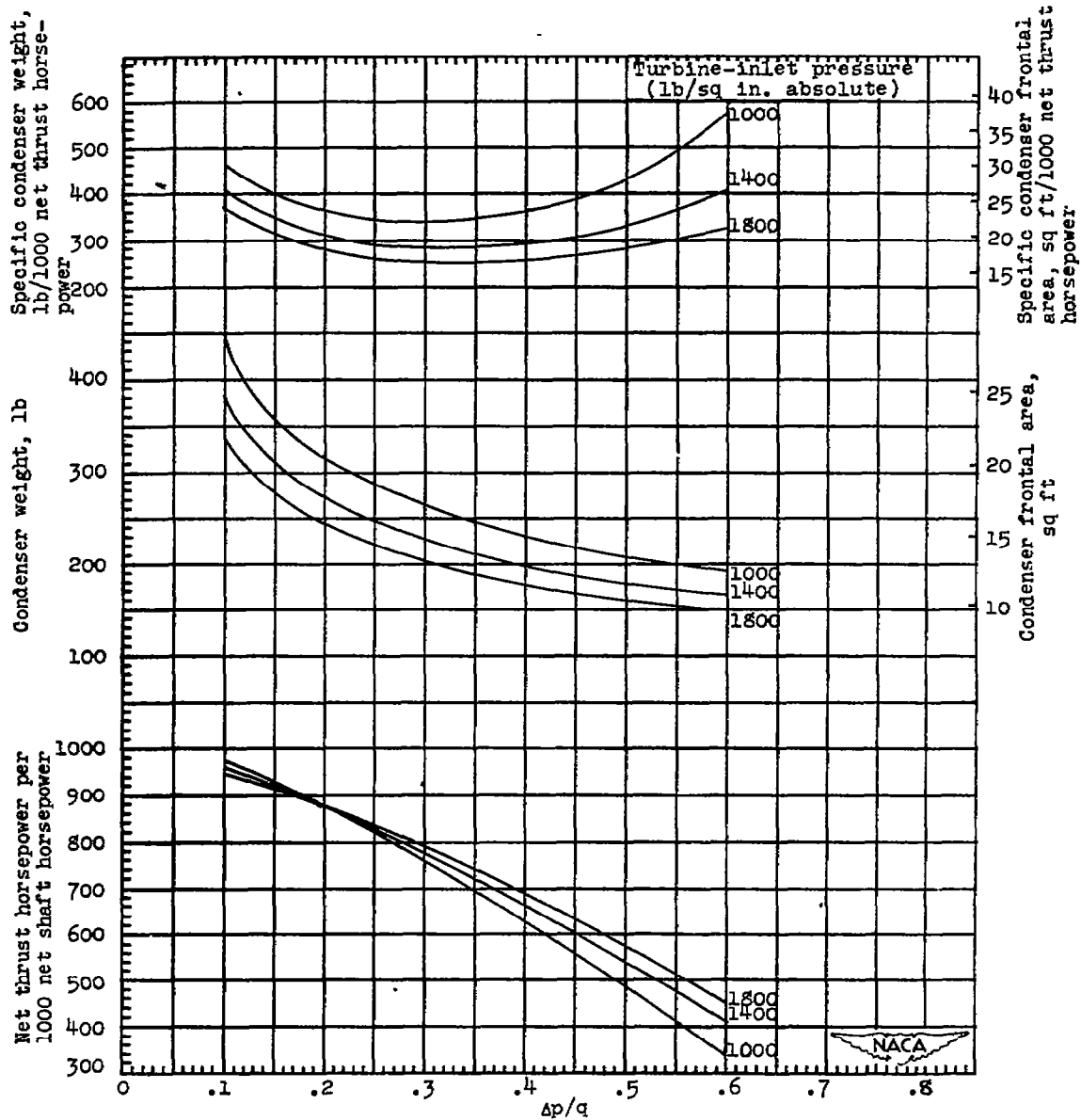

Figure 4. - Variation of net thrust horsepower, condenser weight and frontal area, and specific condenser weight and frontal area with $\Delta p/q$ for three turbine-inlet pressures. Turbine-outlet pressure, 100 pounds per square inch absolute; flight speed, 500 miles per hour; altitude, 30,000 feet; turbine power, 1000 horsepower; turbine and propeller efficiencies, 0.85; saturated steam at turbine outlet.

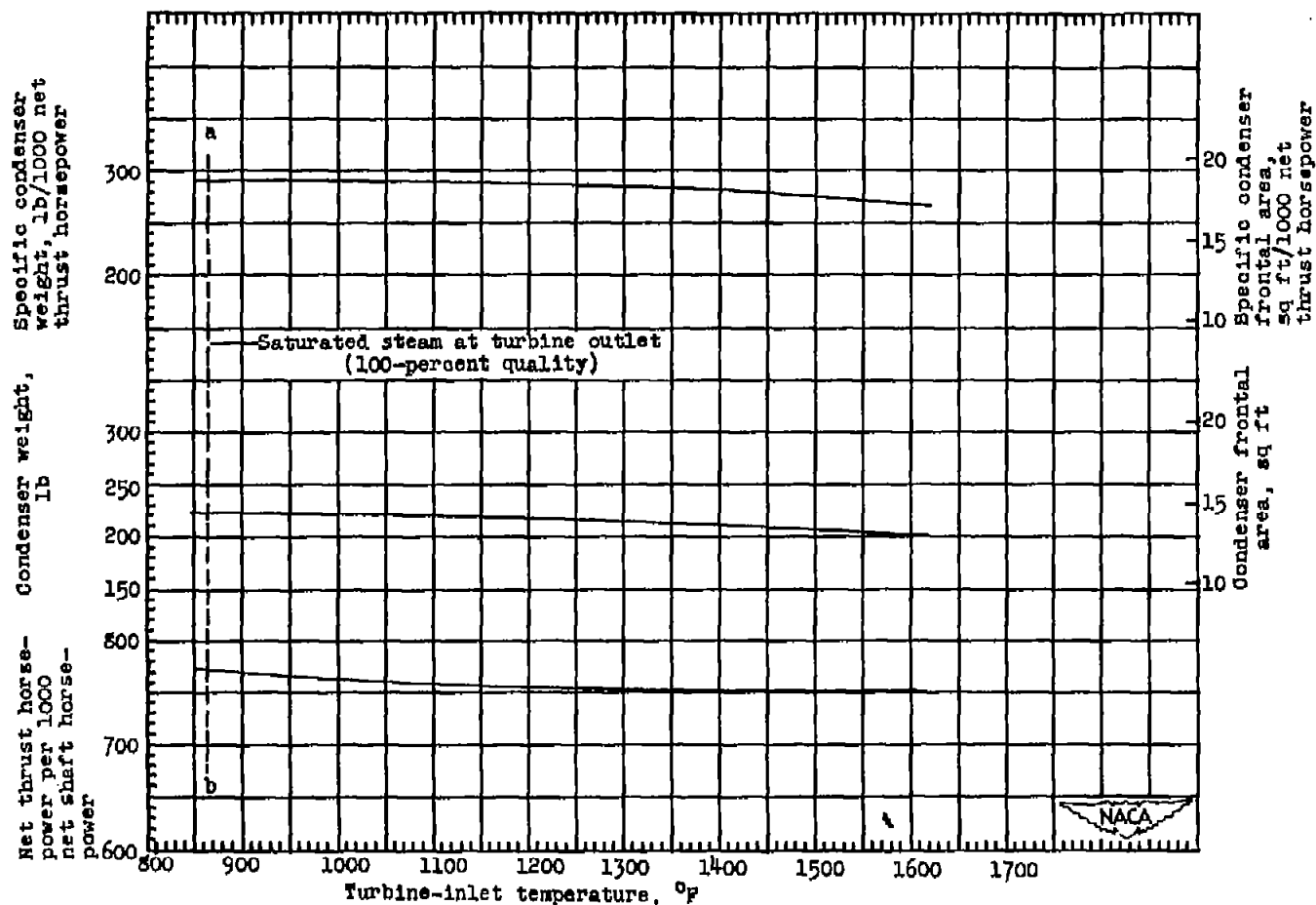

Figure 5. - Variation of net thrust horsepower, condenser weight and frontal area, and specific condenser weight and frontal area with turbine-inlet temperature. Turbine-inlet pressure, 1400 pounds per square inch absolute; turbine-outlet pressure, 100 pounds per square inch absolute; $\Delta p/q$, 0.30; flight speed, 500 miles per hour; altitude, 30,000 feet; turbine power, 1000 horsepower; turbine and propeller efficiencies, 0.85.

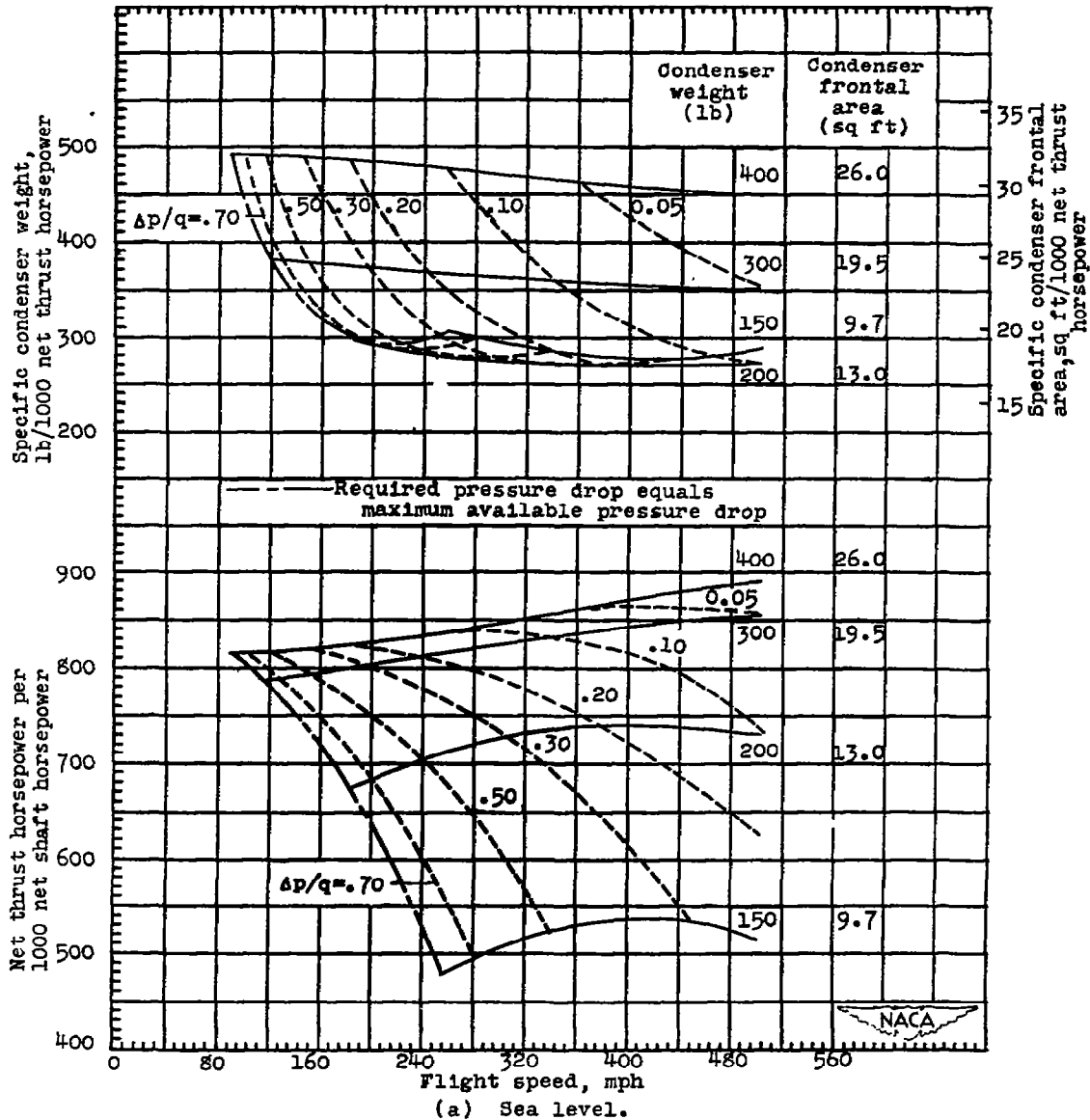

Figure 6. - Variation of net thrust horsepower and specific condenser weight and frontal area with flight speed for various condenser weights and frontal areas. Turbine-inlet pressure, 1400 pounds per square inch absolute; turbine-outlet pressure, 100 pounds per square inch absolute; turbine-inlet temperature, 866° F; turbine power, 1000 horsepower; turbine and propeller efficiencies, 0.85.

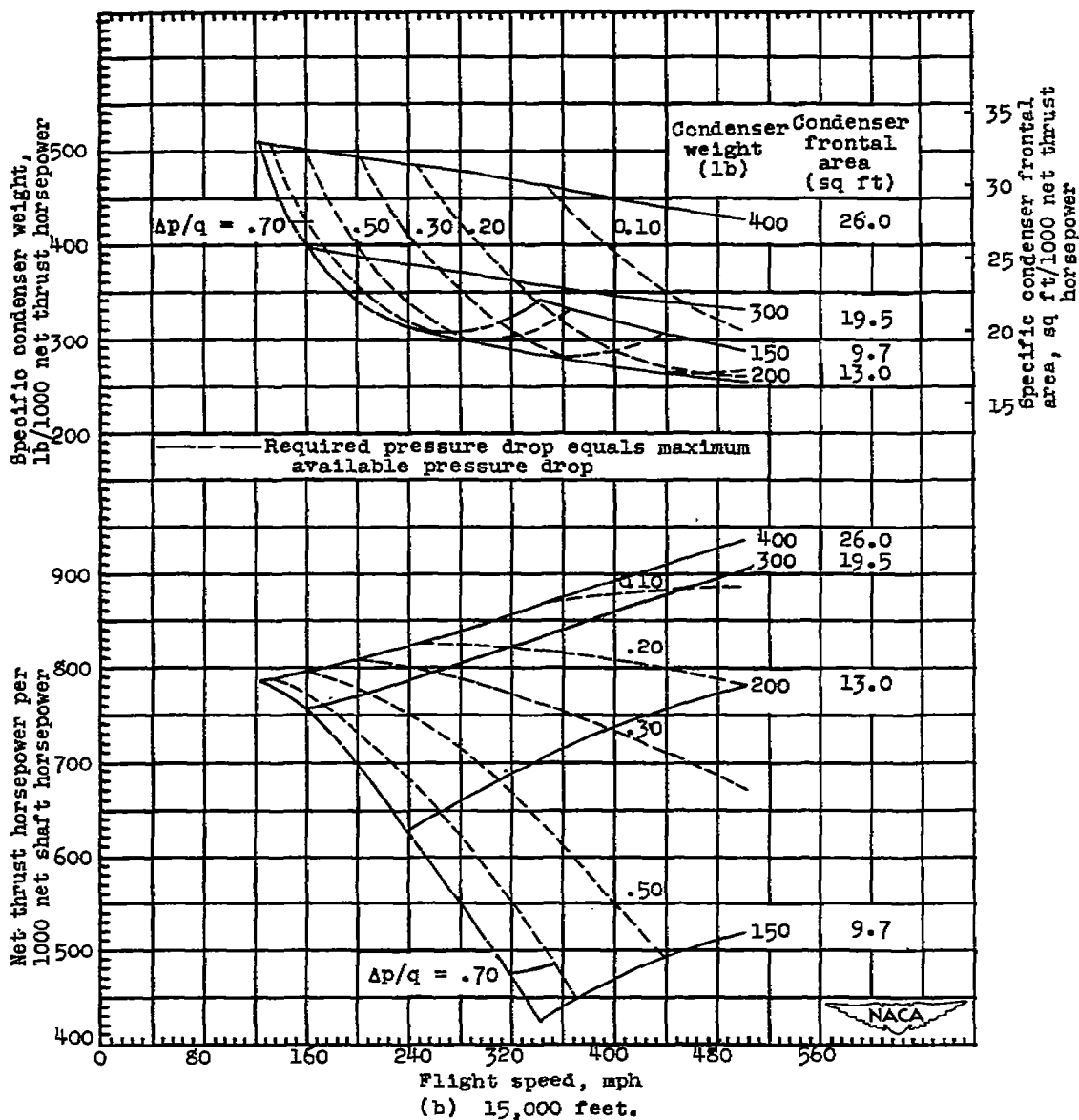

Figure 6. - Continued. Variation of net thrust horsepower and specific condenser weight and frontal area with flight speed for various condenser weights and frontal areas. Turbine-inlet pressure, 1400 pounds per square inch absolute; turbine-outlet pressure, 100 pounds per square inch absolute; turbine-inlet temperature 866° F; turbine power, 1000 horsepower; turbine and propeller efficiencies, 0.85.

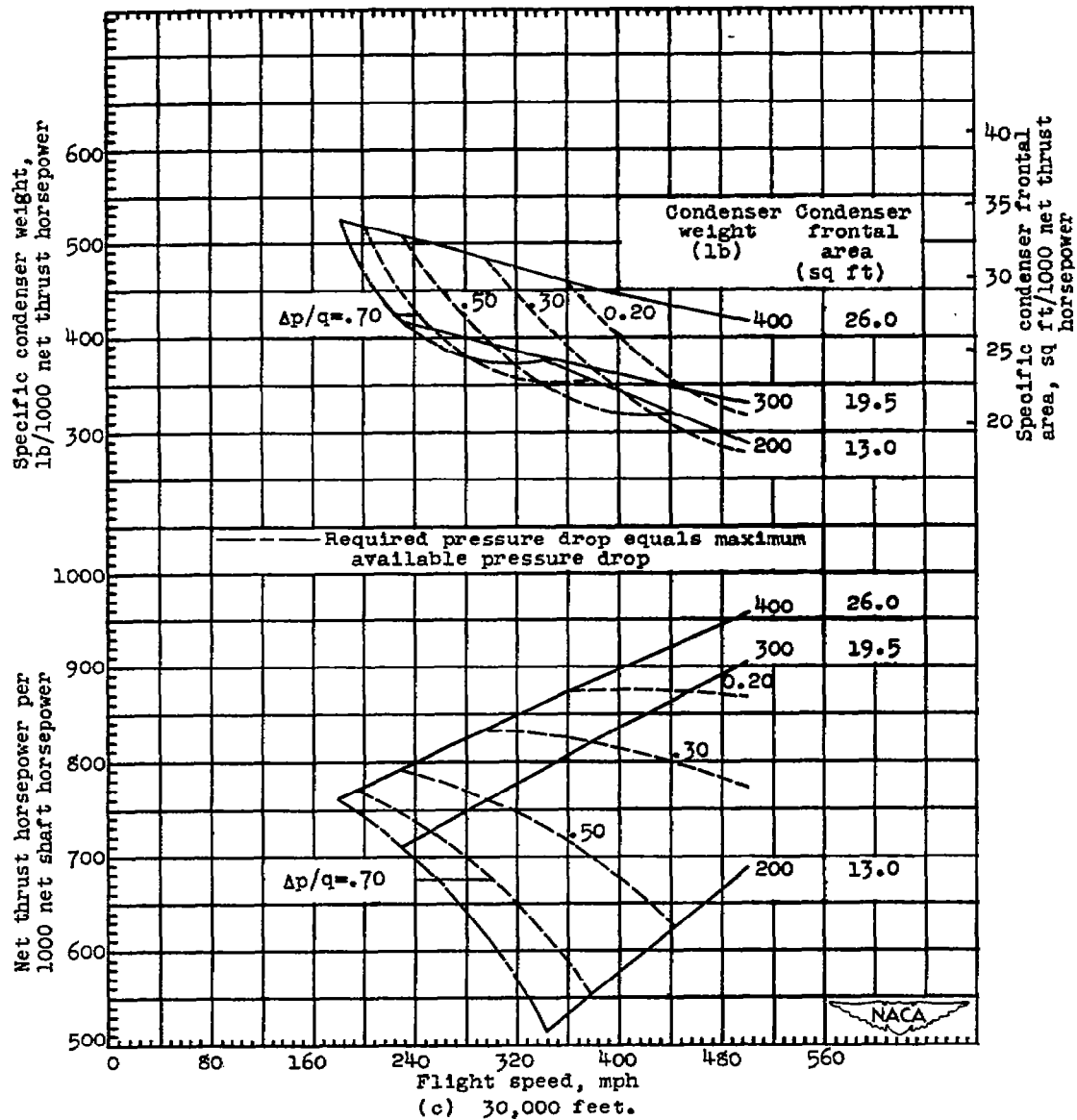

Figure 6. - Concluded. Variation of net thrust horsepower and specific condenser weight and frontal area with flight speed for various condenser weights and frontal areas. Turbine-inlet pressure, 1400 pounds per square inch absolute; turbine-outlet pressure, 100 pounds per square inch absolute; turbine-inlet temperature, 866° F; turbine power, 1000 horsepower; turbine and propeller efficiencies, 0.85.

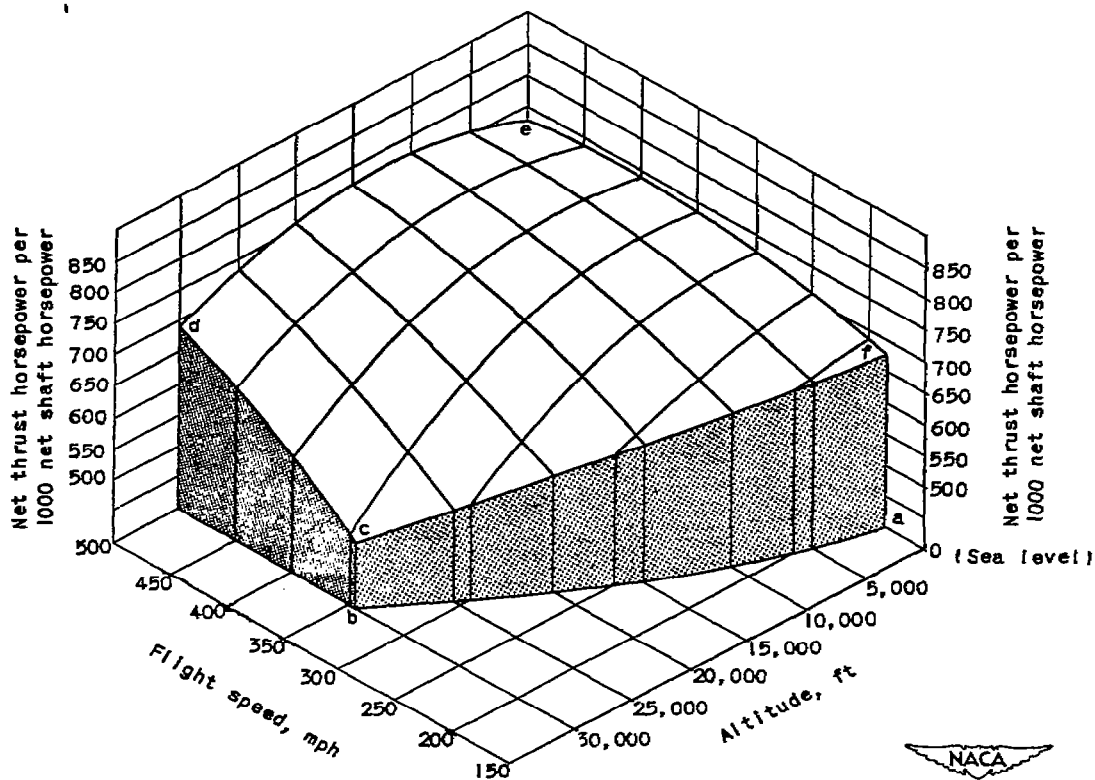

Figure 7. - Variation of net thrust horsepower with flight speed and altitude for condenser having weight of 200 pounds and frontal area of 13.0 square feet. Turbine-inlet pressure, 1400 pounds per square inch absolute; turbine-outlet pressure, 100 pounds per square inch absolute; turbine-inlet temperature, 866° F; turbine power, 1000 horsepower; turbine and propeller efficiencies, 0.85.

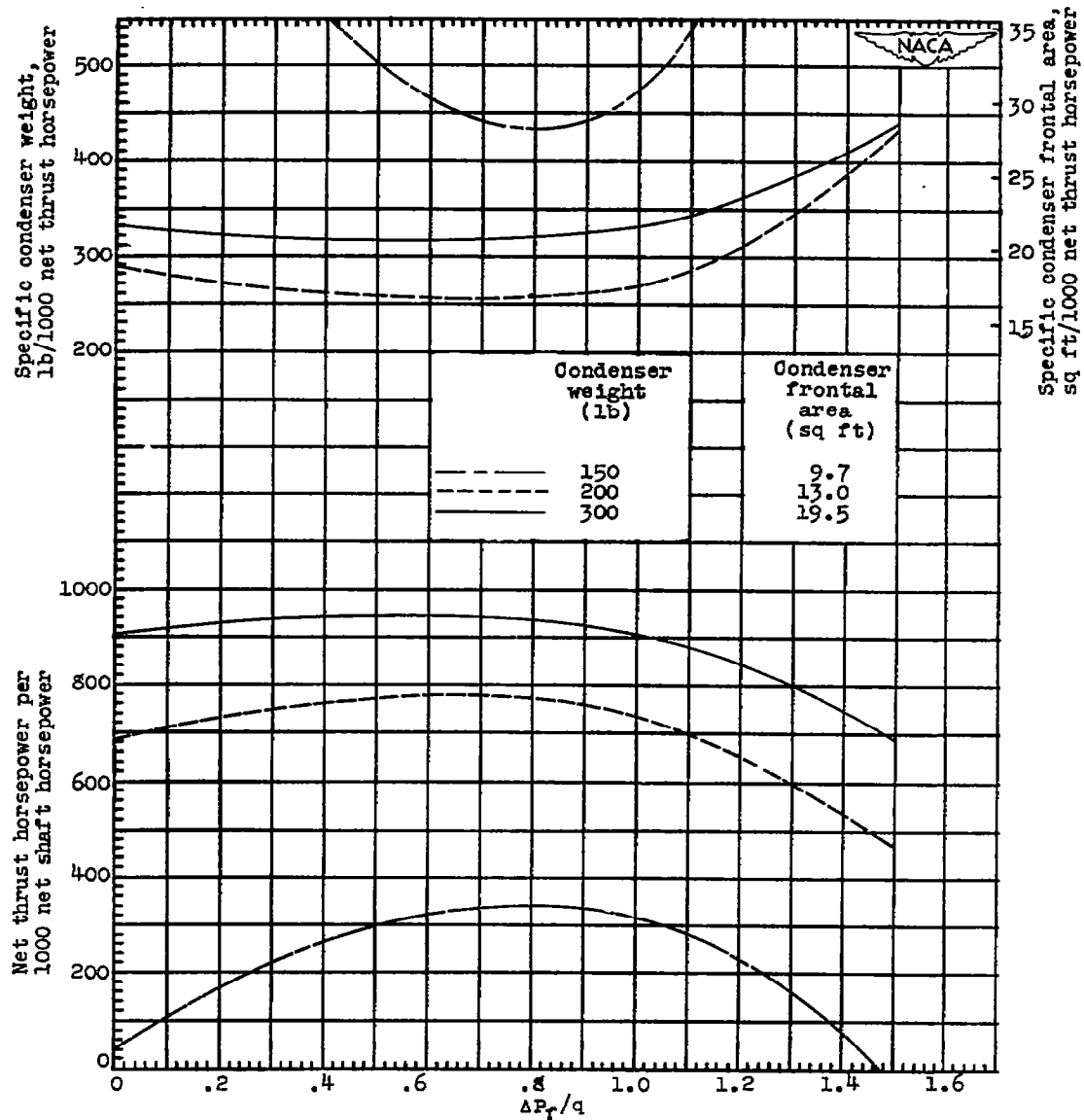

Figure 8. - Variation of net thrust horsepower and specific condenser weight and frontal area with $\Delta P_f/q$ for three condenser weights and frontal areas. Turbine-inlet pressure, 1400 pounds per square inch absolute; turbine-outlet pressure, 100 pounds per square inch absolute; turbine-inlet temperature, 866° F; flight speed, 500 miles per hour; altitude, 30,000 feet; turbine power, 1000 horsepower; turbine, propeller, and fan efficiencies, 0.85.

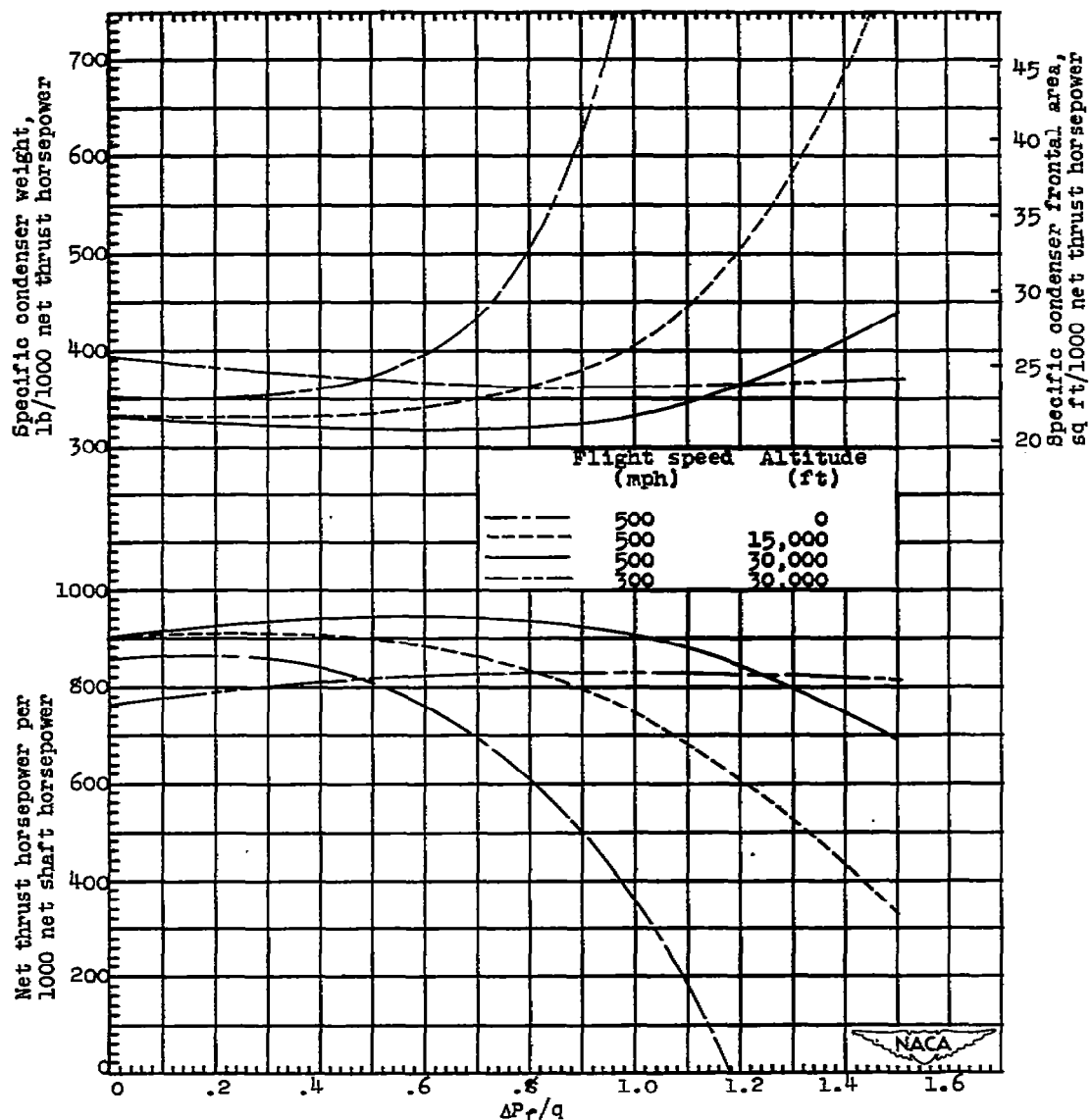

Figure 9. - Variation of net thrust horsepower and specific condenser weight and frontal area with $\Delta P_f/q$ at various flight speeds and altitudes. Condenser weight, 300 pounds; condenser frontal area, 19.5 square feet; turbine-inlet pressure, 1400 pounds per square inch absolute; turbine-outlet pressure, 100 pounds per square inch absolute; turbine-inlet temperature, 866° F; turbine power, 1000 horsepower; turbine, propeller and fan efficiencies, 0.85.

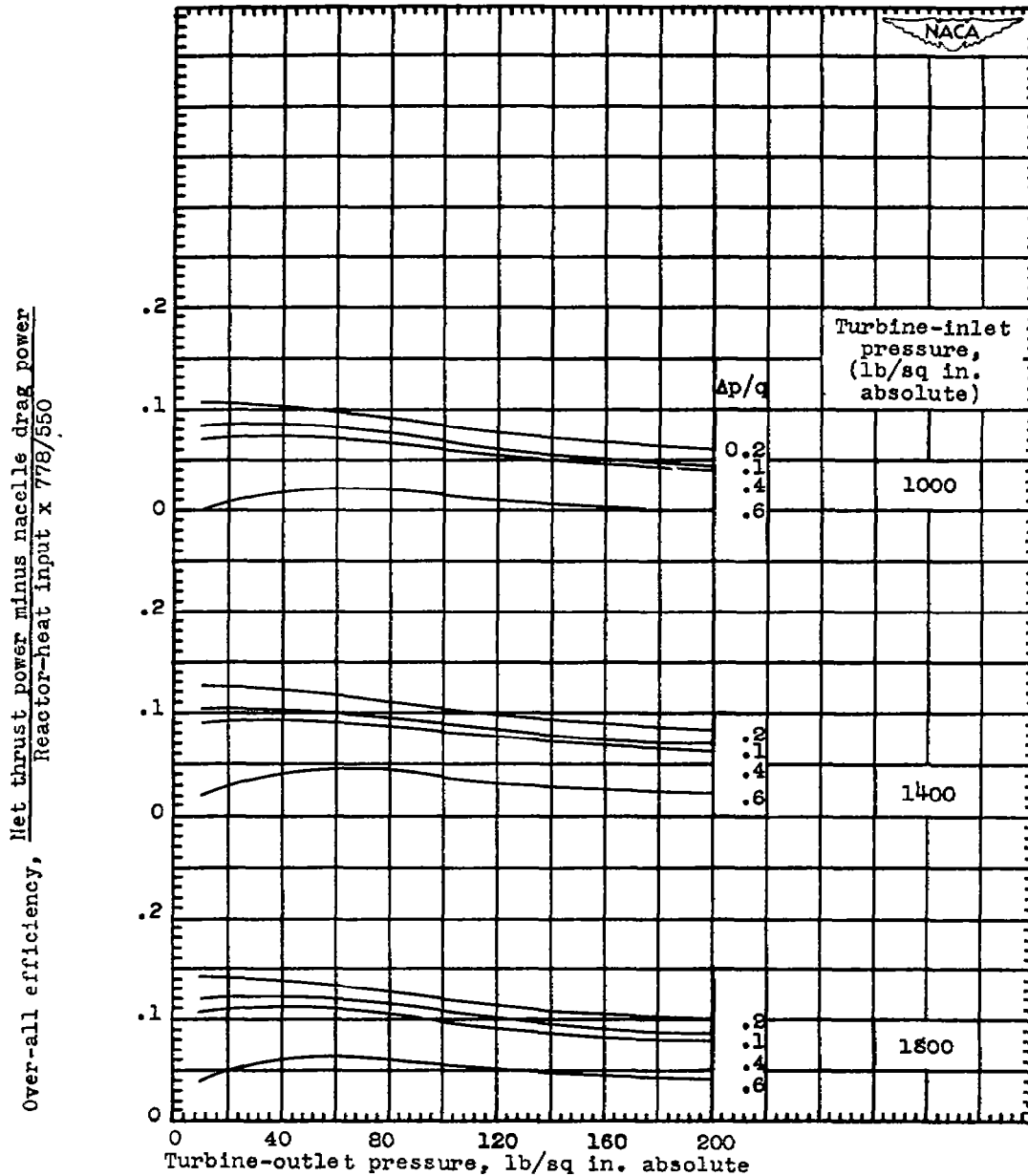

Figure 10. - Variation of over-all efficiency with turbine-outlet pressure for various turbine-inlet pressures and values of $\Delta p/q$. Flight speed, 500 miles per hour; altitude, 30,000 feet; turbine and propeller efficiencies, 0.85; saturated steam at turbine outlet.

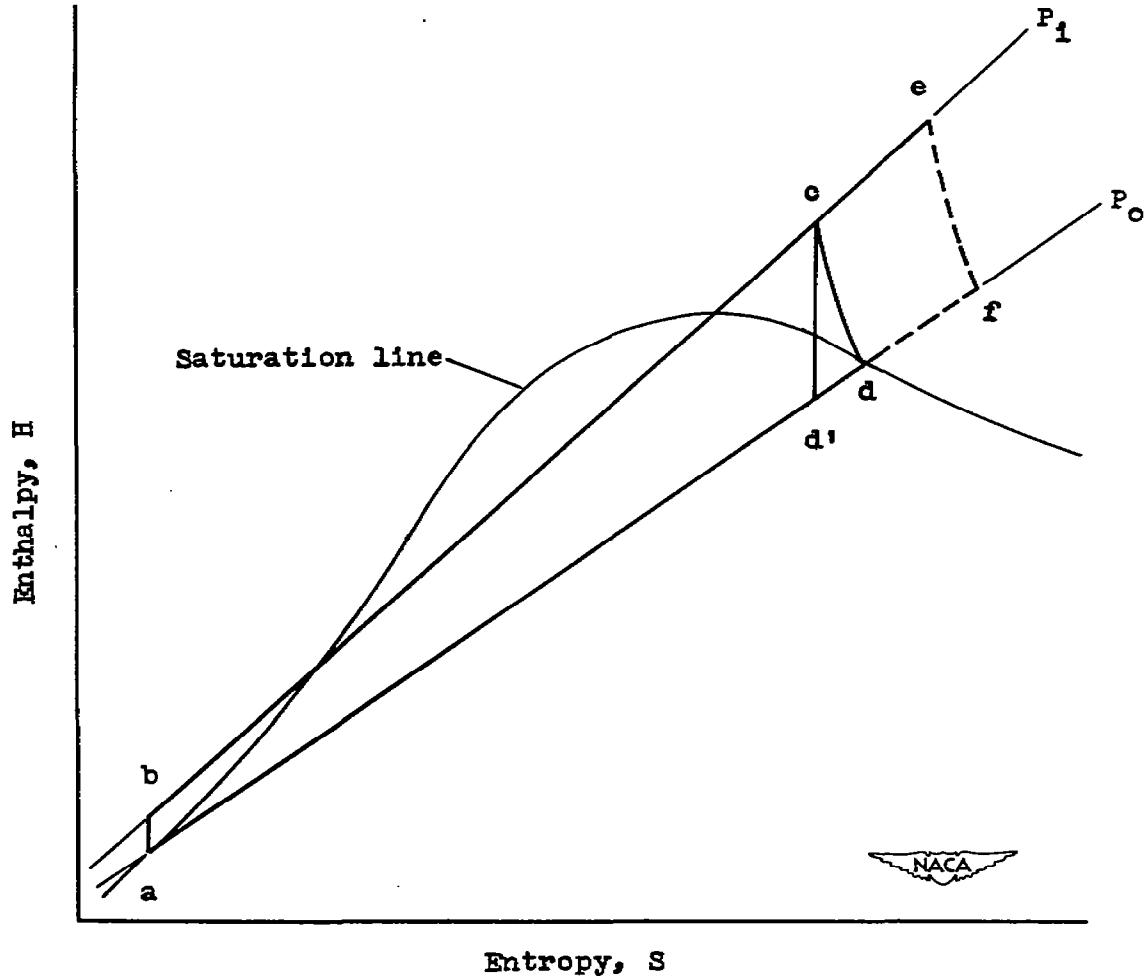

Figure 11. - Schematic diagram of steam cycle.

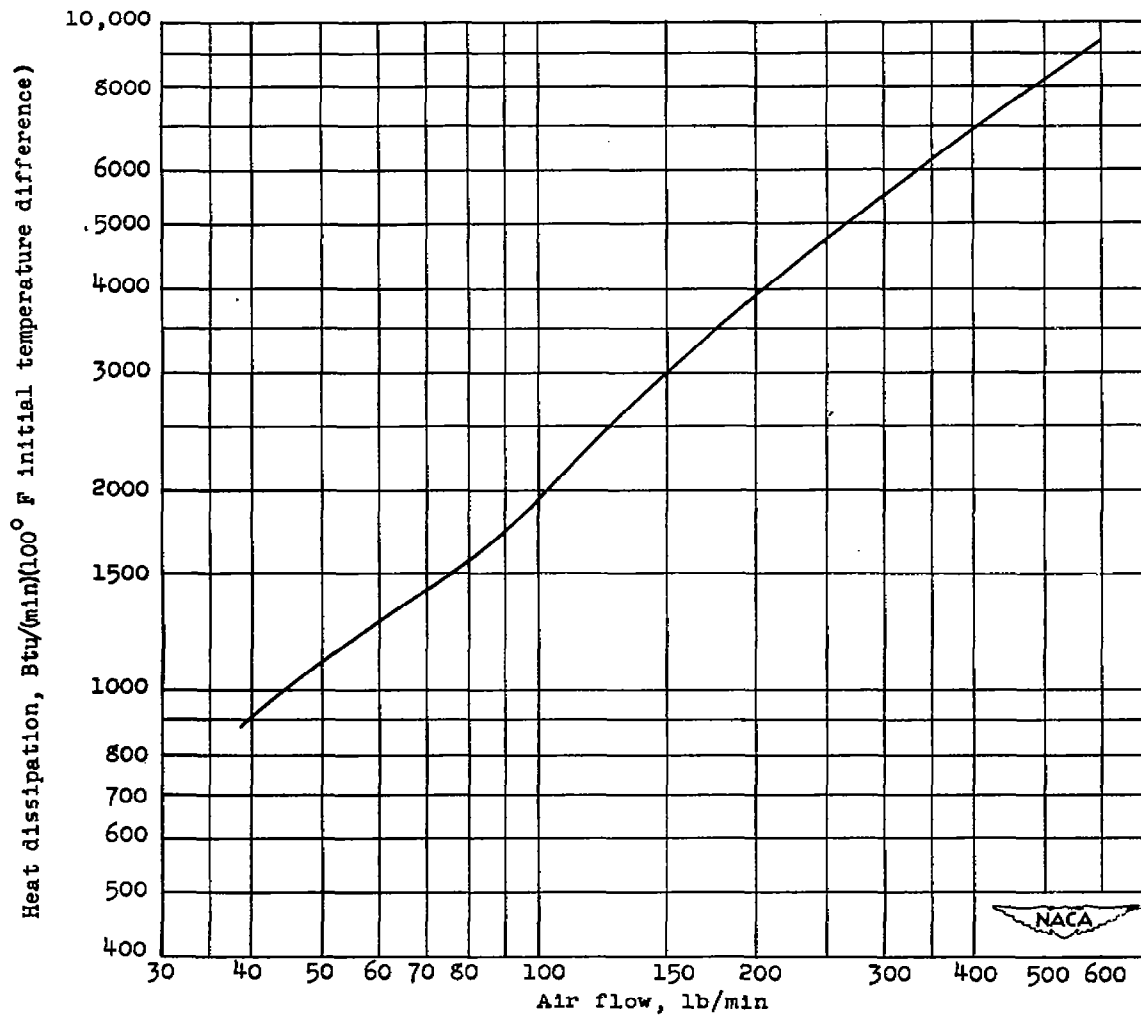

Figure 12. - Variation of heat dissipation with cooling-air flow for a condenser having a frontal area of 1 square foot.

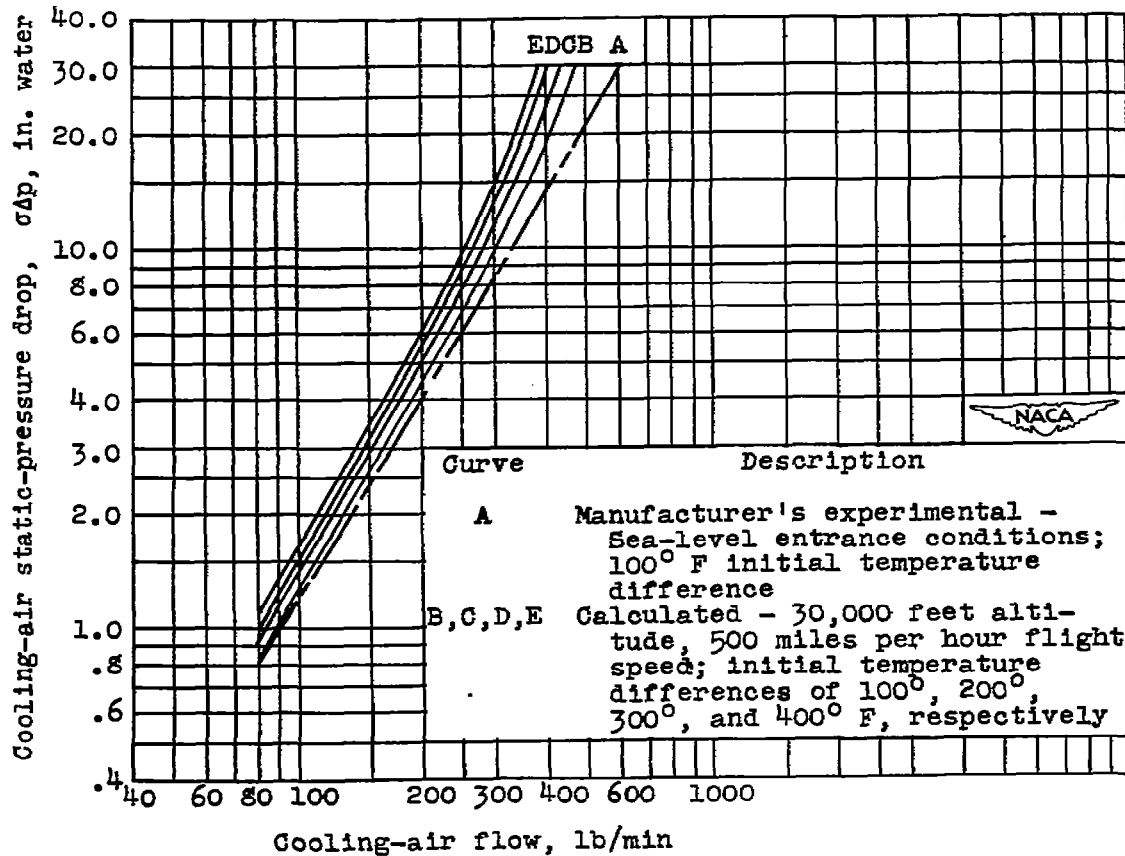
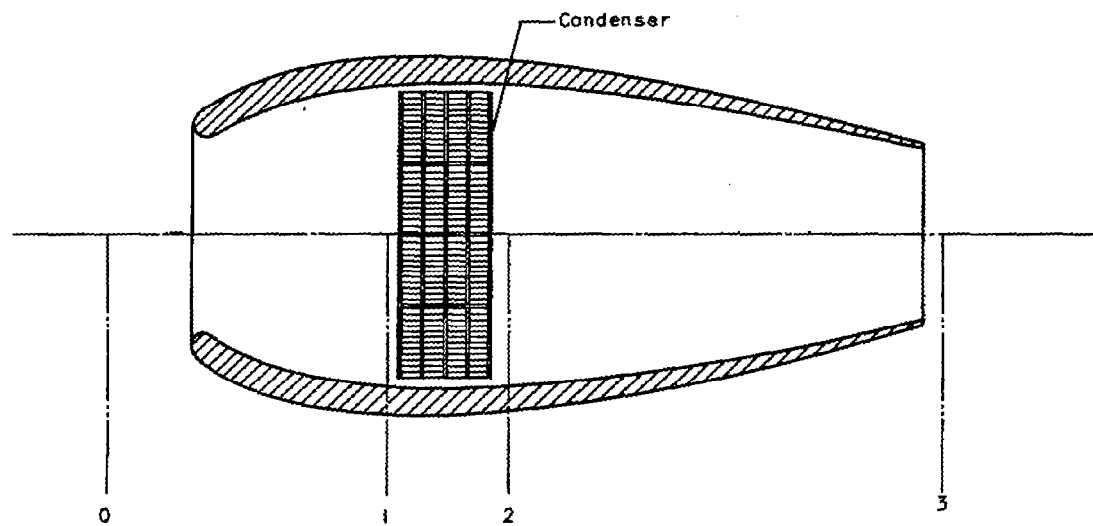
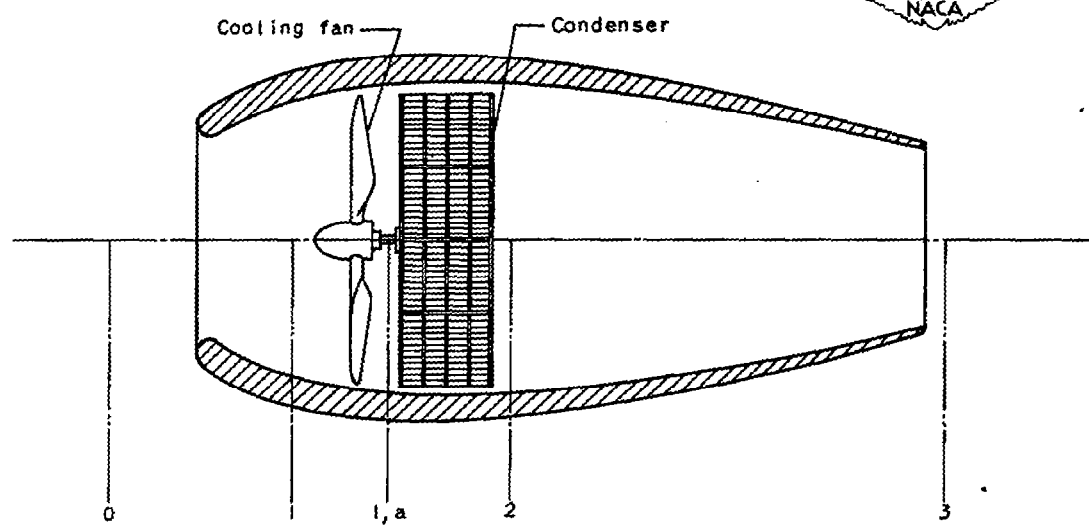

Figure 13. - Variation of cooling-air pressure drop with cooling-air flow for a condenser having a frontal area of 1 square foot.



(a) Without cooling fan.



(b) With cooling fan.

Figure 14. - Schematic diagrams of condenser installation in nacelle.

CONFIDENTIAL

TITLE: Calculated Condenser Performance for a Steam-Turbine Power Plant for Aircraft

ATI-25810

REVISION

(None)

AUTHOR(S): Humble, L. V.; Doyle, R. B.

ORIG. AGENCY NO.

RM-E7J01

ORIGINATING AGENCY: National Advisory Committee for Aeronautics, Washington, D. C.

PUBLISHING AGENCY NO.

(Same)

PUBLISHED BY: (Same)

DATE

May '48

DOC. CLASS.

Conf'd

COUNTRY

U.S.

LANGUAGE

Eng.

PAGES

42

ILLUSTRATIONS

diagrs, graphs

ABSTRACT:

As an application of nuclear energy to aircraft, calculations were made to determine the effect of several operating conditions on the performance of condensers for steam-turbine power plants. The analysis covered a range of turbine-inlet pressures from 1000 to 1800 lb/sq in. absolute, and turbine-outlet pressures from 10 to 200 lb/sq in. absolute for various condenser cooling-air pressure drops, flight speeds, and altitudes. At a turbine-inlet pressure of 1400 lb/sq in. absolute and a turbine-inlet temperature of 866°F, the minimum specific condenser weight was 257 lb/1000 net thrust hp, and the minimum specific condenser frontal area was 16.7 sq ft/1000 net thrust hp. These values occurred at a turbine-outlet pressure of 100 lb/sq in. absolute, a flight speed of 500 mph, and an altitude of about 15,000 ft.

DISTRIBUTION: Request copies of this report only from Originating Agency

DIVISION: Power Plants, Jet and Turbine (5) 27 SUBJECT HEADINGS: Turbines, Steam - Condensers (95523.14);

SECTION: Components (14) 2

~~(97500)~~

Nuclear energy - Propulsion application

ATI SHEET NO.: C-5-14

Air Documents Division, Intelligence Department
Air Materiel CommandAIR TECHNICAL INDEX
CONFIDENTIALWright-Patterson Air Force Base
Dayton, Ohio

(over)

Classification cancelled
or changed to

RESTRICTED

~~NACA Research Abstracts No. 45 dtd 10 July 53~~

AUTH:

By Dorothy S Fischer, OSA
Signature and Grade

Date 6 Oct 53

C auth: ~~NACA Research Abstracts No 56 dtd~~
~~13 Jan 54~~

U auth: NACA Res. abstracts no 74 dtd 30 Nov 54