

NATIONAL ADVISORY COMMITTEE FOR AERONAUTICS

L-225

# WARTIME REPORT

ORIGINALLY ISSUED

December 1944 as  
Restricted Bulletin L4H16

MATERIAL PROPERTIES OF TWO TYPES

OF PLASTIC-BONDED GLASS CLOTH

By Norman Rafel and Evan H. Schuette

Langley Memorial Aeronautical Laboratory  
Langley Field, Va.

PROPERTY OF JET PROPULSION LABORATORY LIBRARY  
CALIFORNIA INSTITUTE OF TECHNOLOGY



WASHINGTON

NACA WARTIME REPORTS are reprints of papers originally issued to provide rapid distribution of advance research results to an authorized group requiring them for the war effort. They were previously held under a security status but are now unclassified. Some of these reports were not technically edited. All have been reproduced without change in order to expedite general distribution.

NATIONAL ADVISORY COMMITTEE FOR AERONAUTICS

RESTRICTED BULLETIN

MATERIAL PROPERTIES OF TWO TYPES  
OF PLASTIC-BONDED GLASS CLOTH

By Norman Rafel and Evan H. Schuette

INTRODUCTION

A number of plastic materials have been proposed for structural use in aircraft. Material properties of these plastics must be established, however, before their use in aircraft structures can be put on a sound basis. Reference 1 presented the results of material-property tests of a plastic-bonded material of glass cloth and canvas and suggested a type of fabrication of plastic-bonded glass cloth which it was hoped might prove superior to the type used in the tests of reference 1. Results are presented herein of tensile and compressive tests of two types of plastic-bonded glass cloth, including a specimen fabricated as suggested in reference 1. The material for these tests was furnished by the Swedlow Aeroplastics Corporation, Glendale, Calif.

DESCRIPTION OF MATERIAL

The two types of glass cloth included in this investigation are identified as rectangular weave (ECC-11-162 Fiberglass fabric) and unidirectional weave (OC-64 Fiberglass fabric); the bonding agent was MR resin. The density of the plastic-bonded rectangular-weave cloth tested was 0.059 pound per cubic inch and of the plastic-bonded unidirectional-weave cloth, 0.056 pound per cubic inch. The rectangular-weave glass-cloth layers were cross-laminated and bonded to produce a plate approximately 1/2 inch thick.

Figure 1 shows the relative directions and spacing of the threads in the surface layer of the plate. The direction along which the arrow is shown is designated the longitudinal direction. Inspection of the material disclosed that the layers were not alternately crossed throughout but were laminated in groups of layers in each direction. The thicknesses of the groups were not constant, and consequently there may have been more layers in one direction than in the other.

The unidirectional-weave glass-cloth layers were similarly cross-laminated and bonded to form a 1/2-inch-thick plate and, as in the case of the rectangular-weave cloth, were not alternately crossed throughout. Figure 2 shows the relative directions of the threads in the surface layer of the bonded unidirectional-weave glass cloth and indicates the longitudinal direction.

### TEST SPECIMENS

Nominal dimensions of the tensile and compressive specimens cut from the 1/2-inch-thick plates are given in figure 3. Three tensile and three compressive specimens were cut from each plate and are identified as having the longitudinal direction of the surface layer parallel, transverse, or at  $45^\circ$  to the axis of the specimen. The compressive specimens were machined on the cut surfaces with particular attention paid to making the loaded surfaces square with the longitudinal axis of the specimen.

One other specimen was supplied. This specimen embodied the same principle as a spirally reinforced concrete column, as suggested in reference 1, and was formed of two crossed layers of unidirectional-weave glass cloth rolled and bonded to form a cylinder as shown in figure 4. The ends were finished square with the axis and the specimen was tested in compression.

### TEST PROCEDURE

The tensile specimens were loaded by applying the loading grips against the edges of the layers. Steel plates, bolted together through the specimen, were attached to the surfaces of the cloth to prevent separation of the layers. (See fig. 3.) The compressive specimens were loaded with the compression heads of the testing machine bearing directly against the flat specimen ends.

Tuckerman optical strain gages of 1-inch gage length were attached at the center of the reduced section of the tensile specimens against the edges of the layers and similarly at the center of the compressive specimens

against the edges of the layers. Four Tuckerman optical strain gages of 2-inch gage length were evenly spaced around the circumference at midheight of the spirally wrapped unidirectional-weave-cloth specimen.

In all tests considerable amounts of creep occurred at the higher loads, and readings were taken in such cases only after the creep had become barely perceptible.

### RESULTS AND DISCUSSION

Results of the tests are presented in table I and in figures 5 to 9. The specimens after failure are shown in figures 10 to 12.

The tensile and compressive stress-strain curves of the plastic-bonded rectangular-weave-cloth specimens are presented in figures 5 and 6, respectively. Both the longitudinal and the transverse tensile specimens failed at a bolt hole, and the ultimate stresses given in figure 5 and table I for these two specimens are stresses in the middle, or test, section at maximum load. The tensile and compressive stress-strain curves for the plastic-bonded unidirectional-weave-cloth specimens are presented in figures 7 and 8, respectively.

For both types of cloth, the ultimate tensile stress and the tensile and compressive yield stresses at  $45^\circ$  to the thread direction were considerably lower than the corresponding stresses parallel or perpendicular to the thread direction. The compressive ultimate stress for the  $45^\circ$  specimens, however, was almost the same as the ultimate stress for the corresponding longitudinal specimens, which seems to indicate that the plastic itself is an important factor in compressive strength, regardless of the direction of the glass threads.

Comparison of the results of the tests of the two types of cloth (see table I) shows that the ultimate compressive stresses were somewhat higher and the compressive yield stresses were very much higher for the unidirectional-weave specimens than for the corresponding rectangular-weave specimens.

The compressive stress-strain curve for the plastic-bonded spirally wrapped unidirectional-weave-cloth specimen

is presented in figure 9. Table I indicates that the modulus of elasticity for this specimen was slightly higher than for any of the others. The ultimate stress, however, was not higher than the ultimate stress obtained from the cross-laminated unidirectional-weave-cloth specimens.

### CONCLUSIONS

Results of tensile and compressive tests of two types of plastic-bonded glass cloth indicated the following conclusions:

1. The ultimate tensile stress and the tensile and compressive yield stresses at  $45^\circ$  to the thread direction were considerably lower than the corresponding stresses parallel or perpendicular to the thread direction.

2. The ultimate compressive stress at  $45^\circ$  to the thread direction was almost the same as the ultimate compressive stress parallel to the thread direction for specimens containing either unidirectional-weave or rectangular-weave cloth, which seems to indicate that the plastic is an important factor in compressive strength, regardless of the direction of the glass threads.

3. The ultimate compressive stresses were somewhat higher and the compressive yield stresses were very much higher for the unidirectional-weave specimens than for the corresponding rectangular-weave specimens.

The use of spirally wrapped unidirectional-weave cloth instead of ordinary cross-laminated cloth had no appreciable effect on the ultimate compressive stress.

Langley Memorial Aeronautical Laboratory  
National Advisory Committee for Aeronautics  
Langley Field, Va.

REFERENCE

1. Zender, George W., Schuette, Evan H., and Weinberger, Robert A.: Data on Material Properties and Panel Compressive Strength of a Plastic-Bonded Material of Glass Cloth and Canvas. NACA TN No. 975, 1944.

TABLE I.- RESULTS OF TENSION AND COMPRESSION TESTS

Load	Surface grain	Modulus of elasticity (psi)	Yield stress (psi) (a)	Ultimate stress (psi)
Rectangular weave				
Tensile	Longitudinal	$1.9 \times 10^6$	15,500	<sup>b</sup> 17,100
	Transverse	1.7	15,500	<sup>b</sup> 20,100
	45°	1.1	5,900	13,800
Compressive	Longitudinal	$1.7 \times 10^6$	8,000	10,100
	Transverse	1.8	8,800	10,600
	45°	.9	4,600	10,100
Unidirectional weave				
Tensile	Longitudinal	$1.8 \times 10^6$	15,200	20,900
	Transverse	1.7	16,800	25,300
	45°	1.0	4,600	10,900
Compressive	Longitudinal	$1.6 \times 10^6$	13,800	13,900
	Transverse	1.7	16,800	16,800
	45°	.9	6,600	14,600
Spirally wrapped				
Compressive	-----	$2.0 \times 10^6$	-----	12,800

<sup>a</sup>0.2-percent-offset method.

<sup>b</sup>Stresses in test section at maximum load; failure occurred at bolt hole.

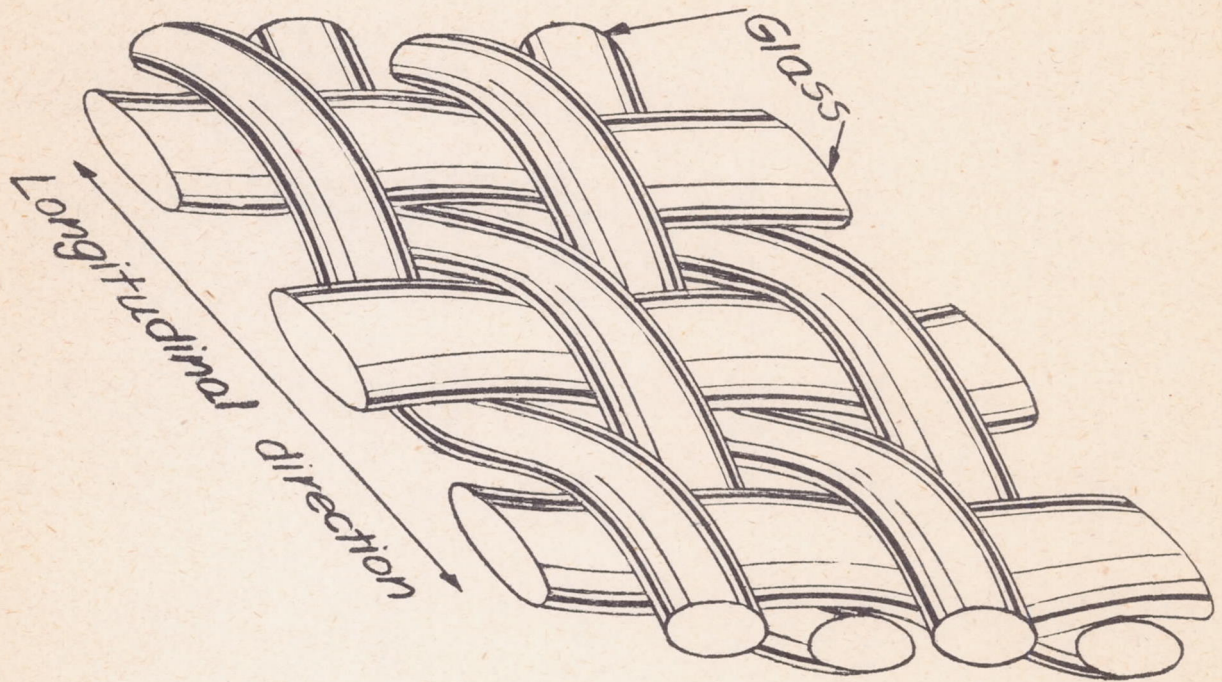

Surface layer

NATIONAL ADVISORY  
COMMITTEE FOR AERONAUTICS

Figure 1.-Relative directions and spacing of threads in rectangular-weave cloth.

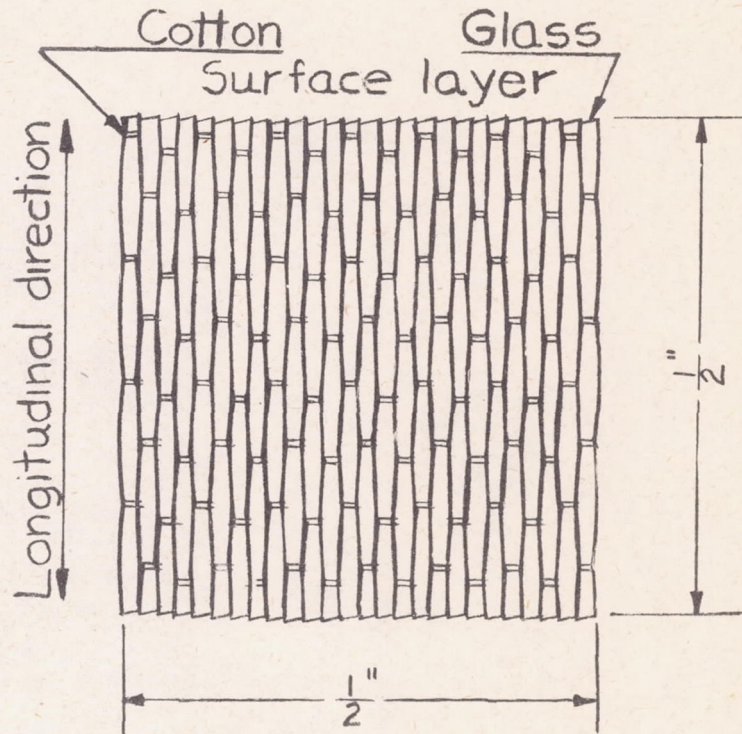

NATIONAL ADVISORY  
COMMITTEE FOR AERONAUTICS

Figure 2.- Unidirectional-weave cloth.

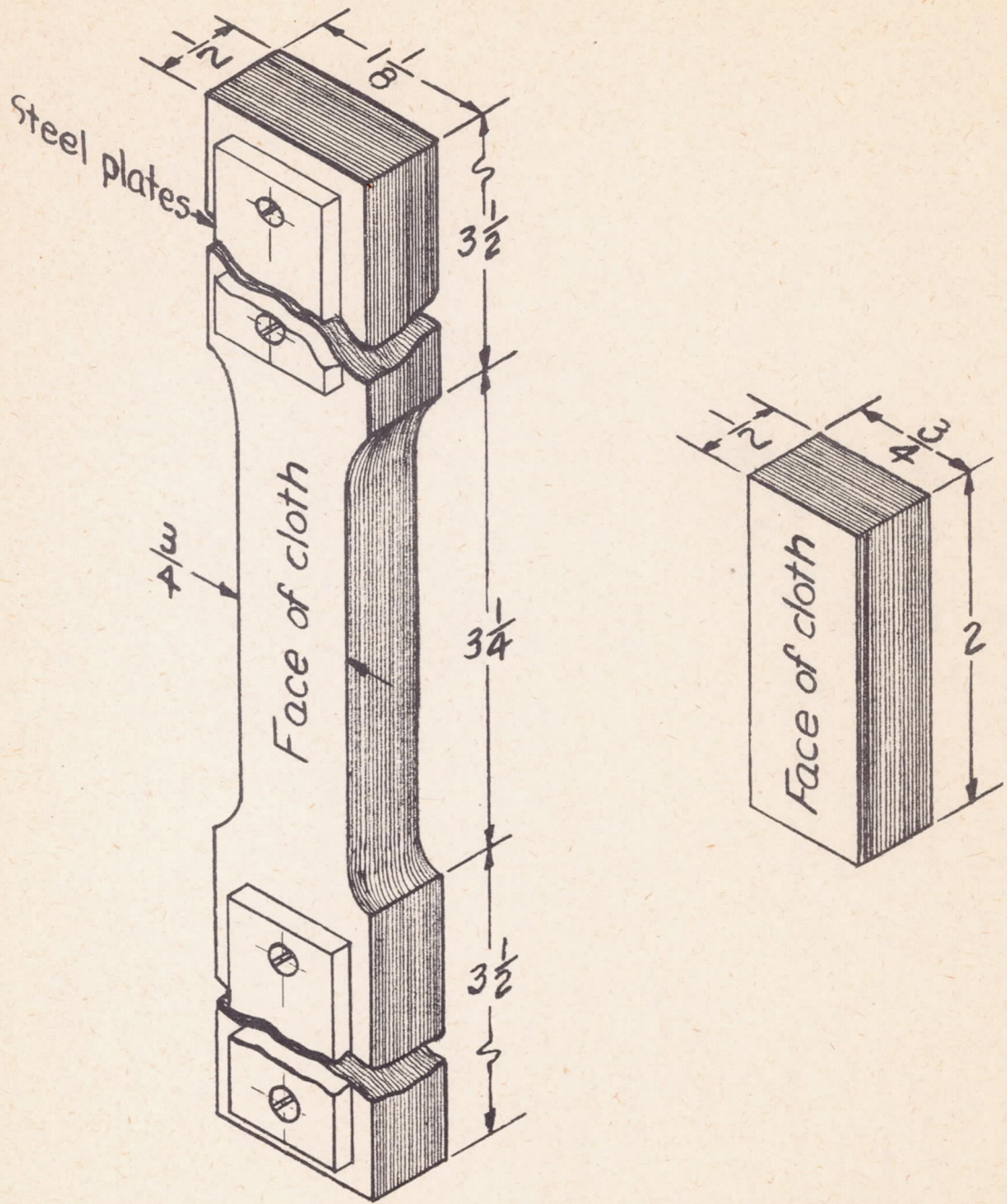

NATIONAL ADVISORY  
COMMITTEE FOR AERONAUTICS

Figure 3.- Nominal dimensions of tensile and compressive specimens.

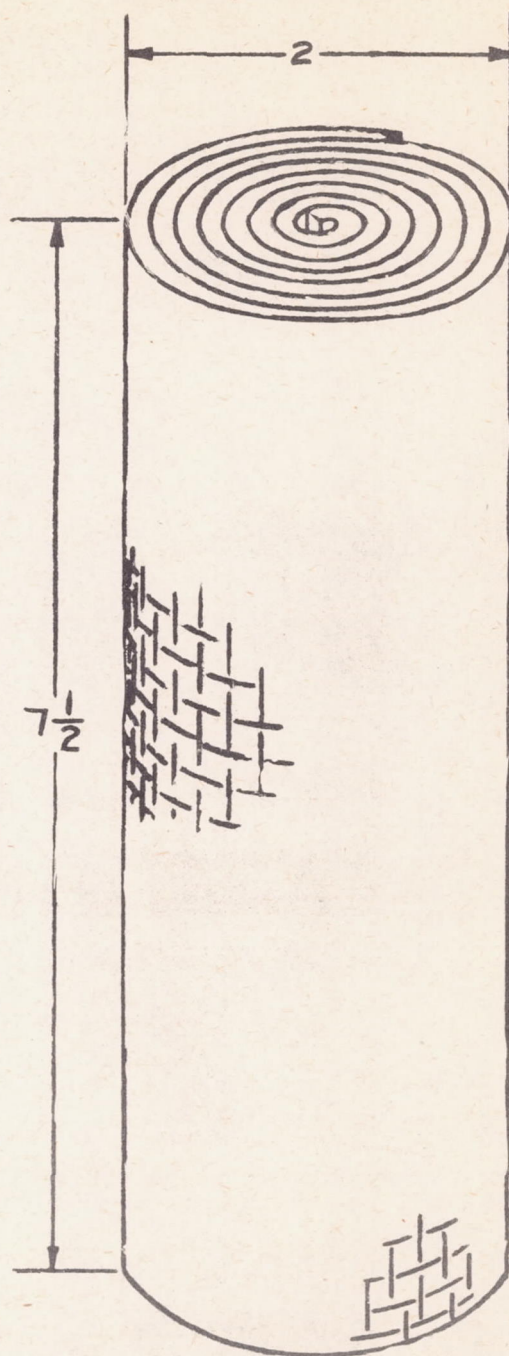

NATIONAL ADVISORY  
COMMITTEE FOR AERONAUTICS

Figure 4.- Nominal dimensions of spirally wrapped unidirectional-weave-cloth specimen.

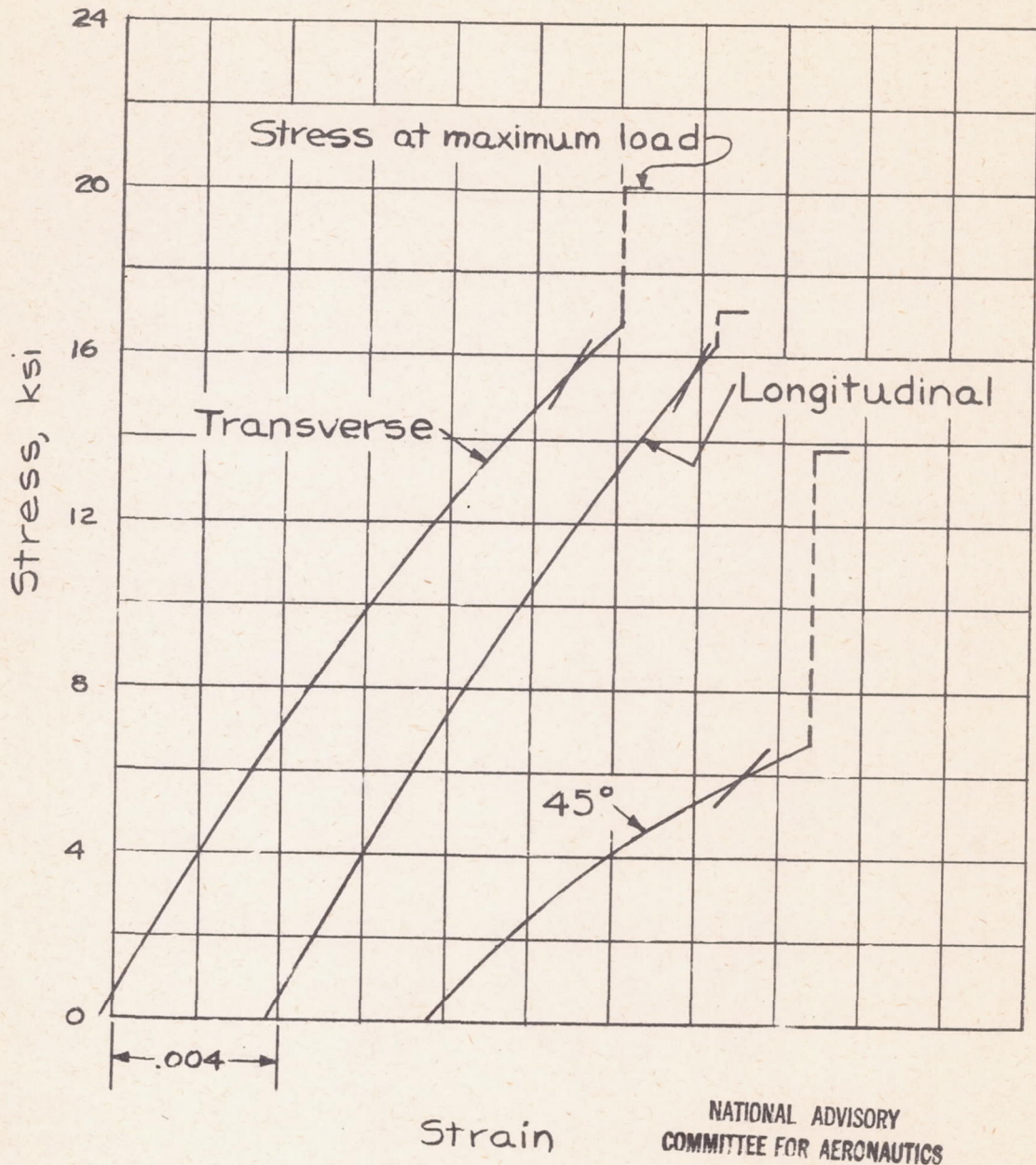

Figure 5.- Tensile stress-strain curves for plastic-bonded rectangular-weave cloth.

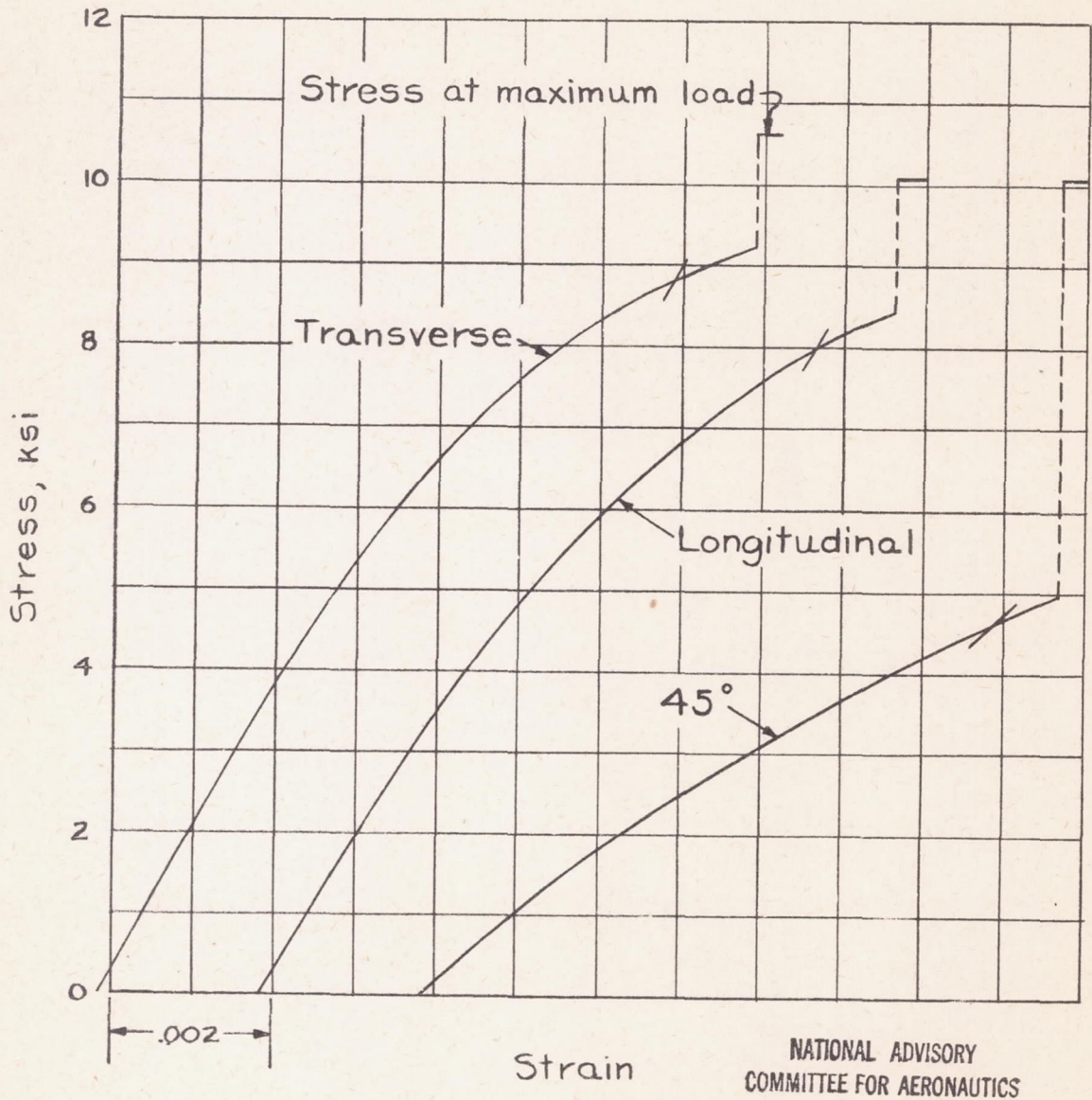

Figure 6.- Compressive stress-strain curves for plastic-bonded rectangular-weave cloth.

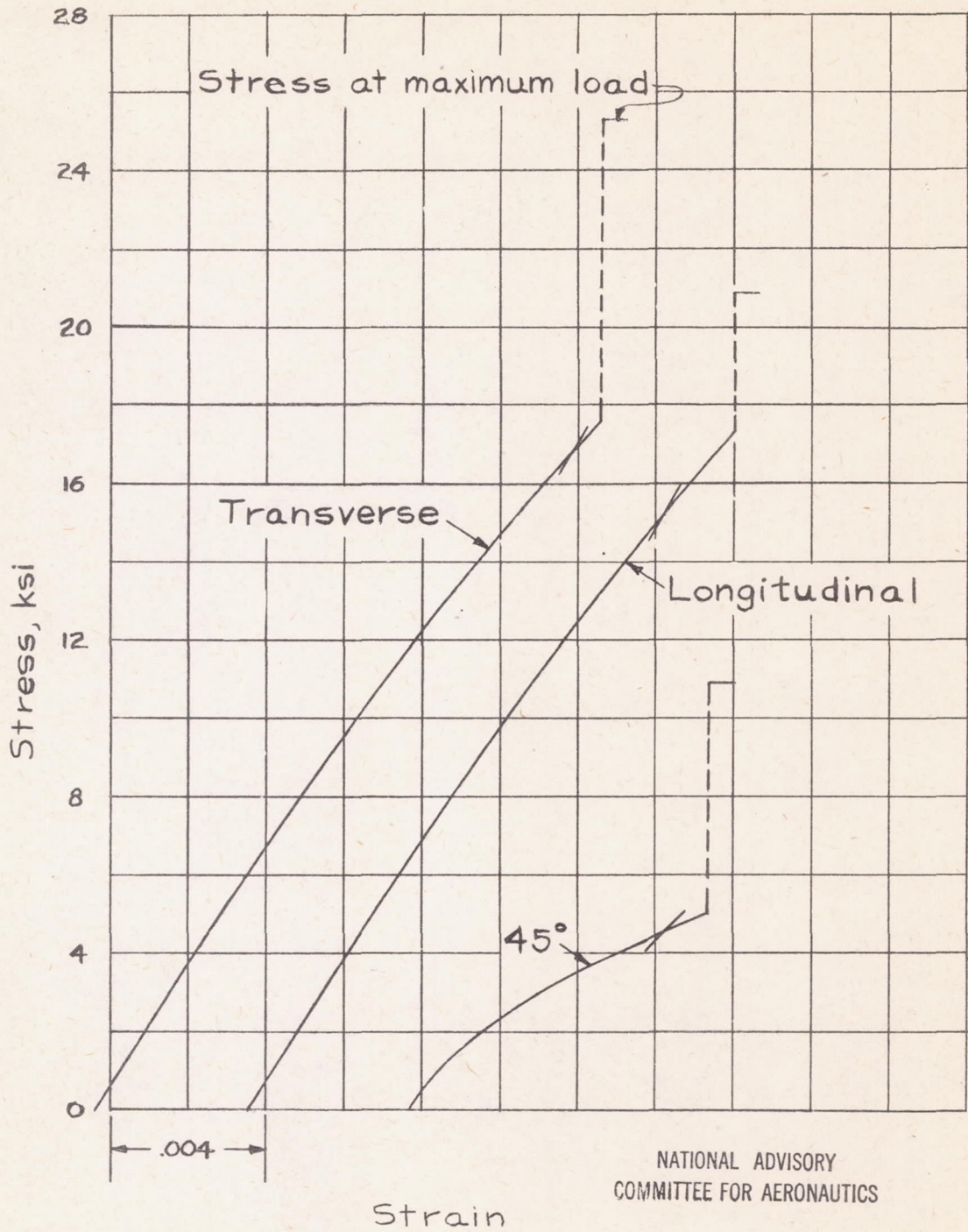

Figure 7.-Tensile stress-strain curves for plastic-bonded unidirectional-weave cloth.

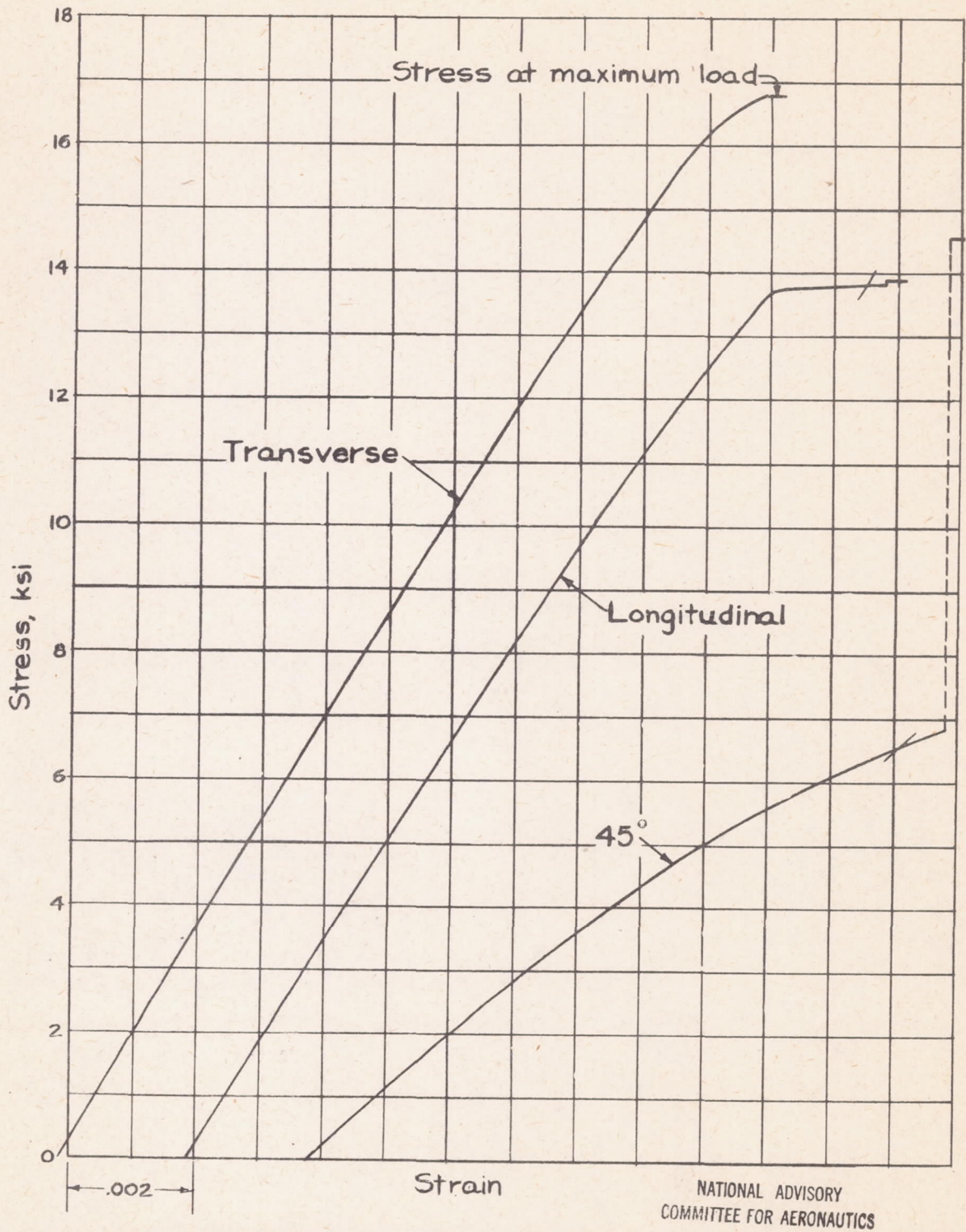

Figure 8.-Compressive stress-strain curves for plastic-bonded unidirectional-weave cloth.

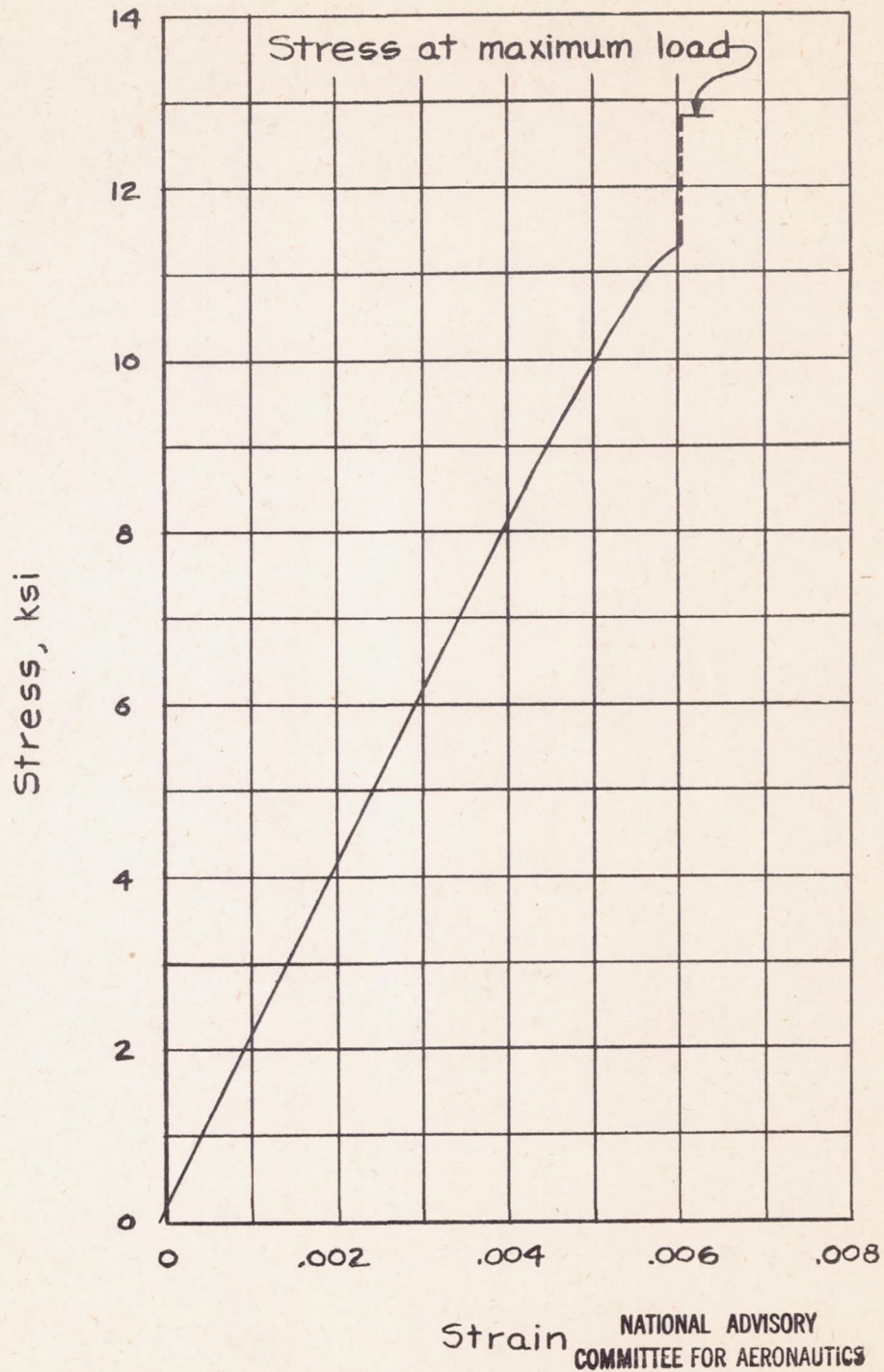
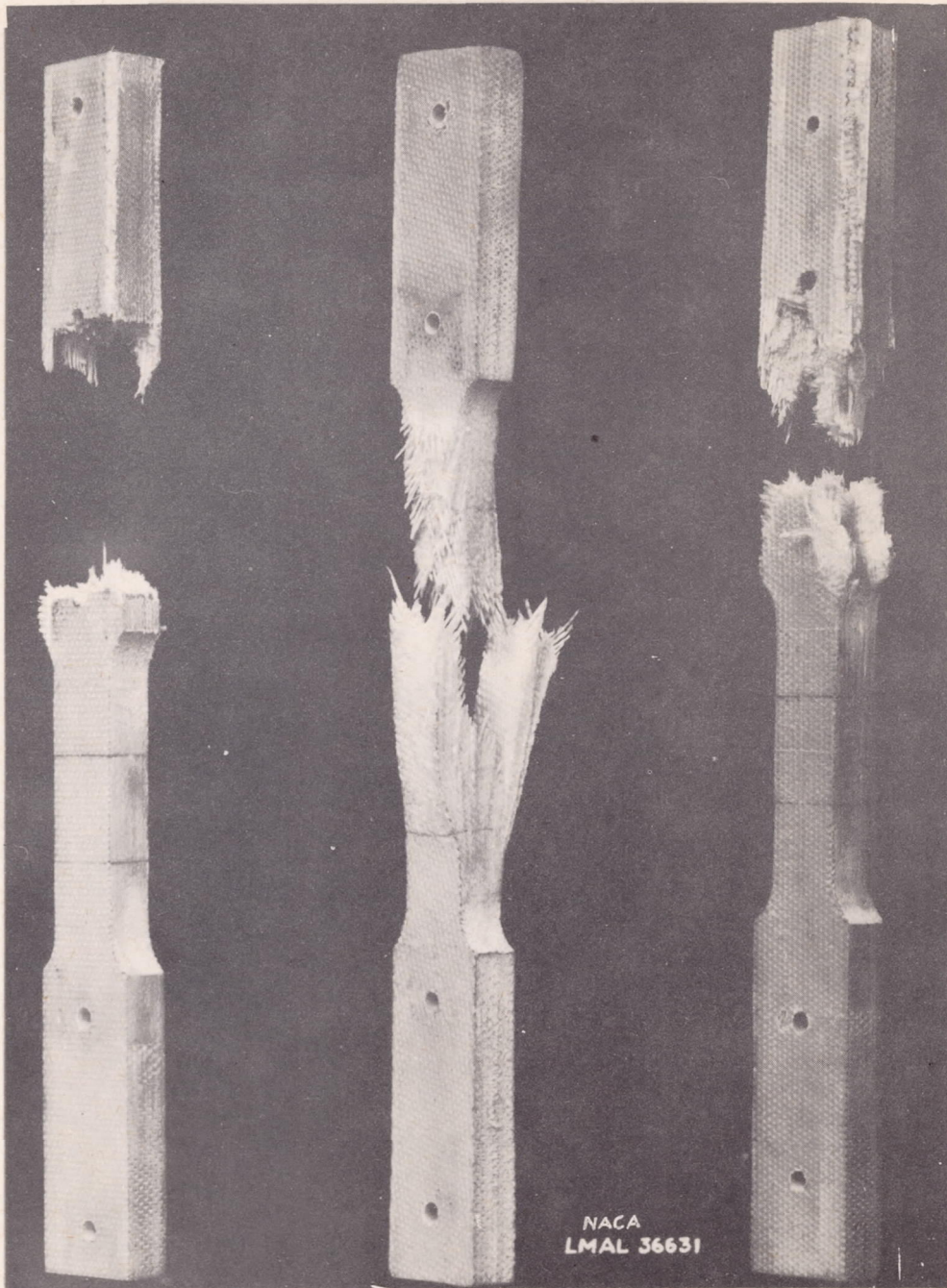

Figure 9.- Compressive stress-strain curve for plastic-bonded spirally wrapped unidirectional-weave cloth.



Longitudinal

45°

Transverse

(a) Rectangular weave.

Figure 10.- Tensile specimens after failure.

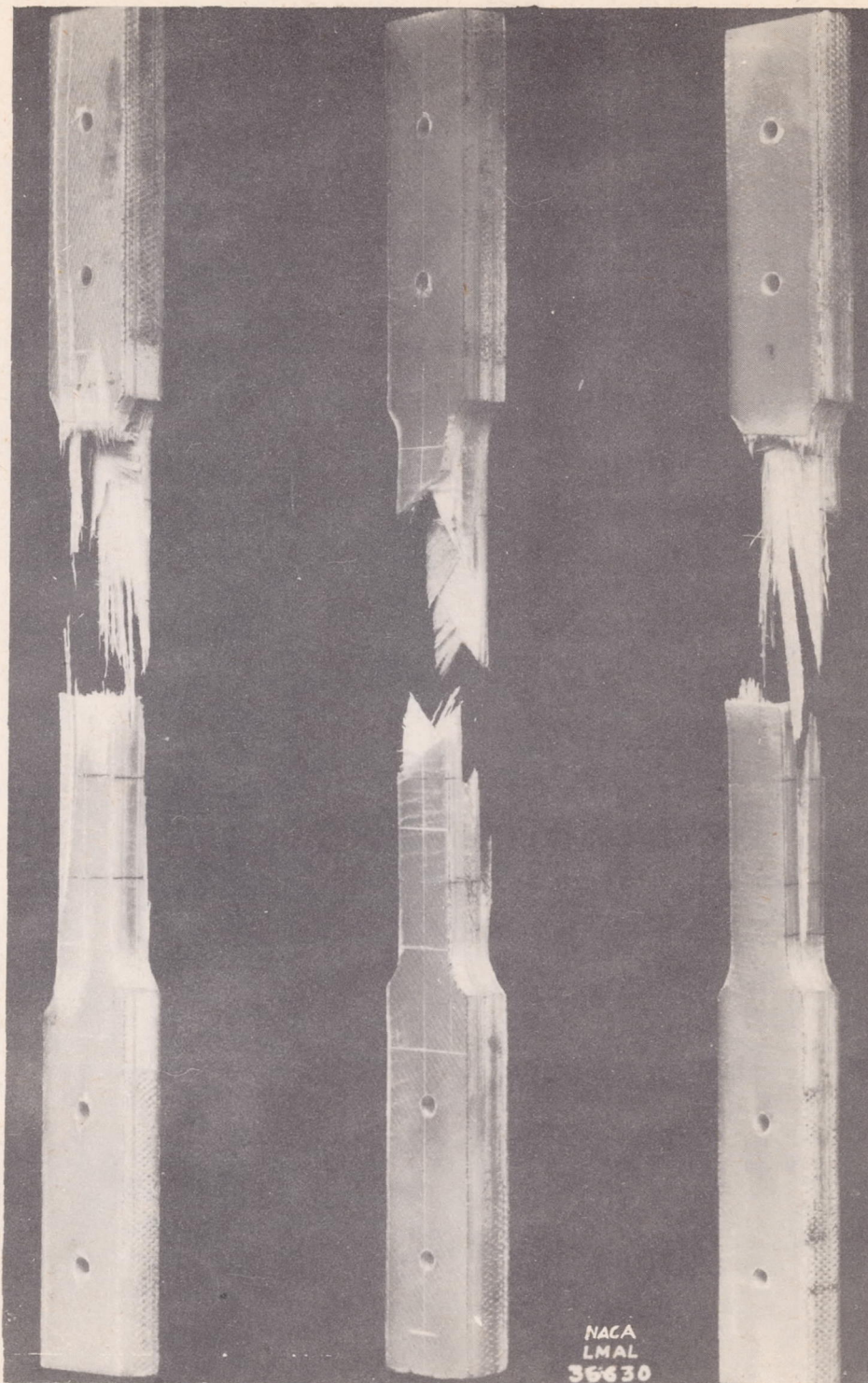

Longitudinal

45°

Transverse

(b) Unidirectional weave.

Figure 10.- Concluded.

### Rectangular weave

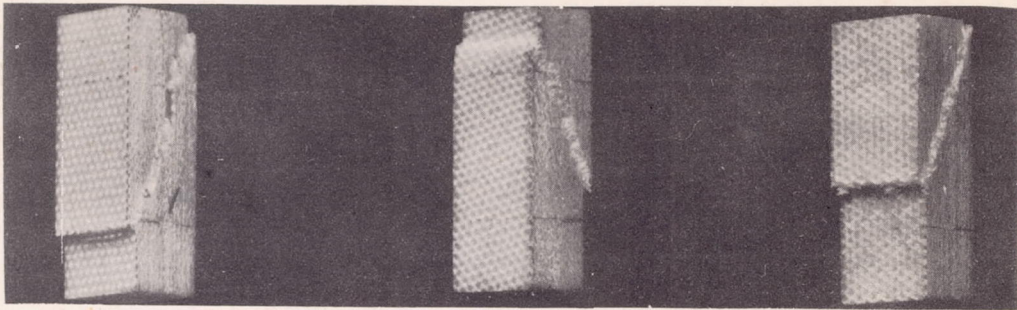

Longitudinal

45°

Transverse

### Unidirectional weave

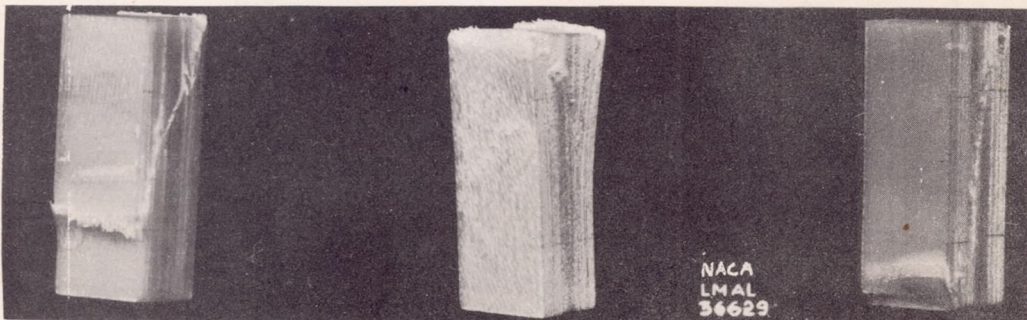

Longitudinal

45°

Transverse

Figure 11.- Compressive specimens after failure.

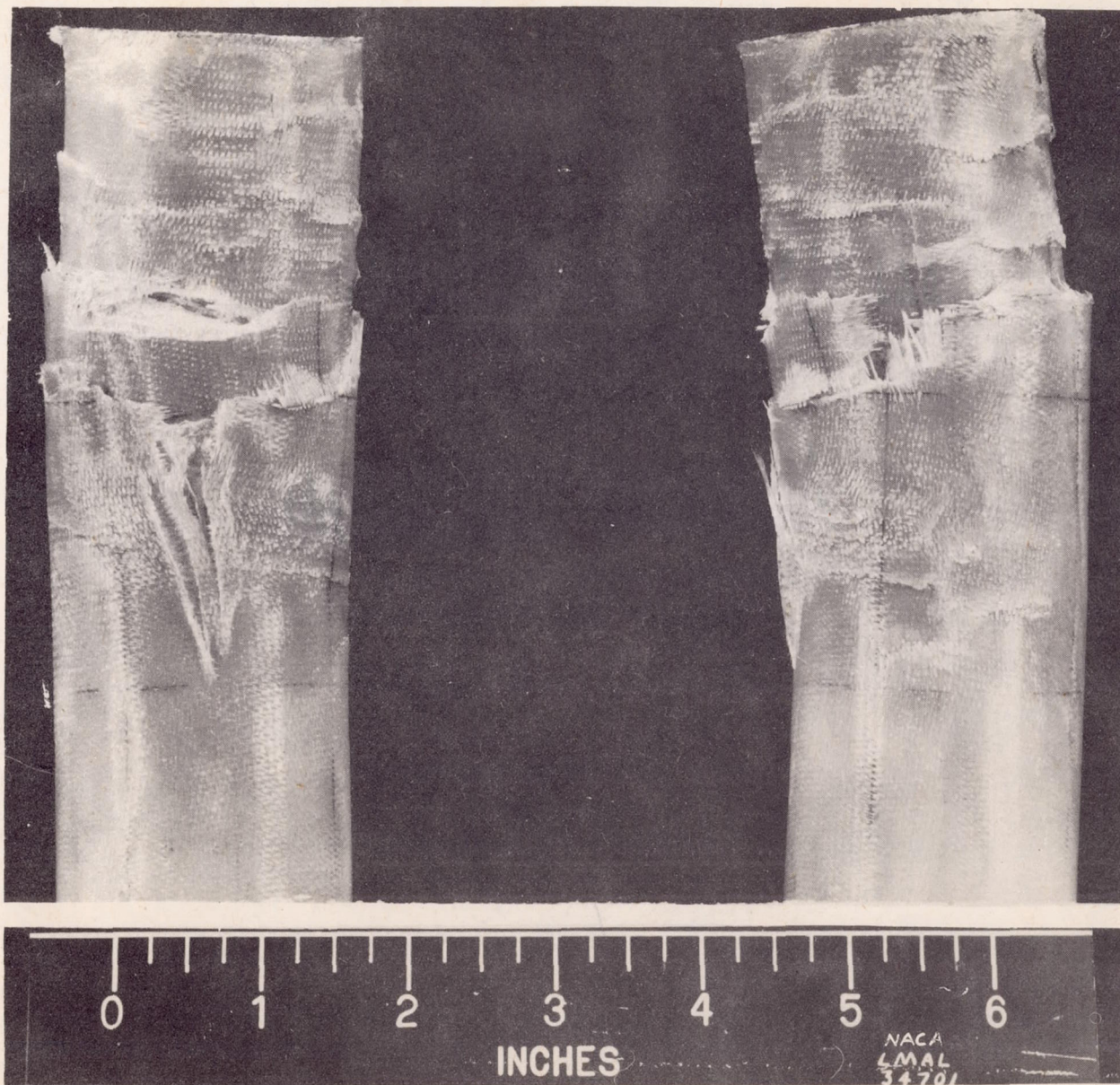

Fig. 12

Figure 12.- Front and side views of spirally wrapped unidirectional-weave-cloth specimen after failure.

TITLE: Material Properties of two Types of Plastic-Bonded Glass Cloth

ATI- 13201

REVISION none

AUTHOR(S): Rafel, Norman ; Schuette, E. H.

ORIGINATING AGENCY: National Advisory Committee for Aeronautics, Washington, D. C.

ORIG. AGENCY NO.  
RB-L4H16

U

DATE	DOC. CLASS	COUNTRY	LANGUAGE	PAGES	ILLUSTRATIONS
Dec '44	Unclass.	U.S.	Eng.	19	photos, table, diagrs, graphs

ABSTRACT:

OVER

An investigation was made of the material properties of two types of glass cloth to determine their suitability for structural use in aircraft. One of the specimens tested was of rectangular weave, while the other was unidirectional; both employed MR resin as a bonding agent. The test procedure for the testing of three tensile and three compressive specimens are described in detail. Results indicate ultimate tensile stress and the tensile and compressive yield stresses at 45° to the thread direction were lower than corresponding stresses parallel or perpendicular to thread direction.

DISTRIBUTION: Request copies of this report only from Originating Agency

DIVISION: Materials (8)	14	SUBJECT HEADINGS: Glass cloth, Laminated (45635); Material - Testing (60498); Stress analysis (90800); Strength of materials (90750)
SECTION: Leather and Textiles (5)		
ATI SHEET NO.: R-8-5-6	4	

Air Materiel Command  
U. S. Air Force

AIR TECHNICAL INDEX

Wright-Patterson Air Force Base  
Dayton, Ohio